

# CMOS MONOSTABLE/ASTABLE MULTIVIBRATOR

## FEATURES

- Low Power Consumption
- Monostable (one-shot) or (Astable) Operation
- True and Complementary Buffered Outputs
- Only One External R and C Required
- Enabled with either a Low or a High Level in Astable Mode
- Triggered on either a Low to High or High to Low Transition in Monostable Mode
- Asynchronous Master Reset
- Output Pulse Width Independent of Trigger Pulse, in Monostable Mode
- May Be Utilized as Free Running or Gated Oscillator, in Astable Mode

## DESCRIPTION

4047B is capable of operating in either the monostable or astable mode. It requires an external capacitor (between pins 1 and 3) and an external resistor (between pins 2 and 3) to determine the output pulse width in the monostable mode, and the output frequency in the astable mode.

Astable operation is enabled by a high level on the astable input or low level on the astable input. The output frequency (at 50% duty cycle) at Q and  $\bar{Q}$  outputs is determined by the timing components. A frequency twice that of Q is available at the Oscillator Output; a 50% duty cycle is not guaranteed.

## BLOCK DIAGRAM

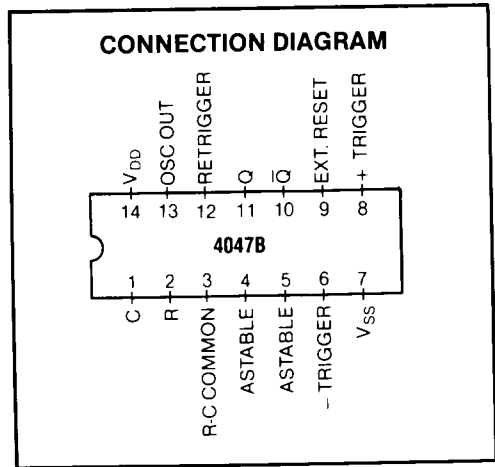
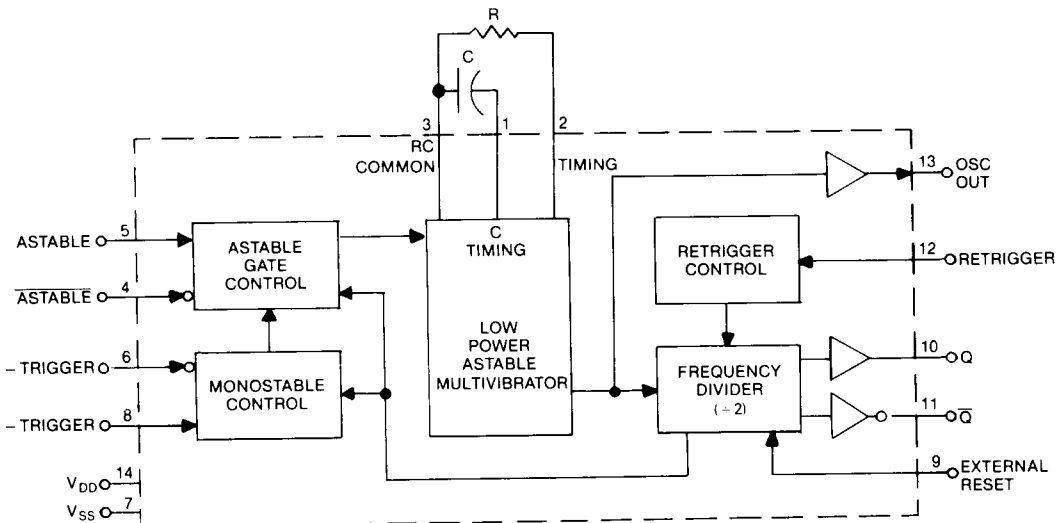

Monostable operation is obtained when the device is triggered by low-to-high transition at + trigger input or high-to-low transition at -trigger input. The device can be retriggered by applying a simultaneous low-to-high transition to both the + trigger and retrigger inputs.

A high level on Reset input resets the outputs Q to low,  $\bar{Q}$  to high.

**Absolute Maximum Ratings**

$V_{DD}$ DC Supply Voltage	- 0.5 to +18V <sub>DC</sub>
$V_{IN}$ Input Voltage	- 0.5 to $V_{DD}$ + 0.5V <sub>DC</sub>
$T_S$ Storage Temperature Range	- 65°C to +150°C
$P_D$ Package Dissipation	500mW
$T_L$ Lead Temperature (Soldering, 10 seconds)	300°C

**Recommended Operating Conditions**

$V_{DD}$ DC Supply Voltage	3 to 15V <sub>DC</sub>
$V_{IN}$ Input Voltage	0 to $V_{DD}$ V <sub>DC</sub>
$T_A$ Operating Temperature Range	- 55°C to +125°C
SCL4047BC, D, F, H	- 55°C to +125°C
SCL4047BE	- 40°C to +85°C

**ELECTRICAL CHARACTERISTICS****STATIC CHARACTERISTICS**<sup>1</sup>

PARAMETER	$V_{DD}$ (Vdc)	CONDITIONS	$T_{LOW}$ <sup>2</sup>		+25°C			$T_{HIGH}$ <sup>2</sup>		Units
			Min.	Max.	Min.	Typ.	Max.	Min.	Max.	
QUIESCENT DEVICE CURRENT	$I_{DD}$	$V_{IN}=V_{SS}$ or $V_{DD}$ All valid input combinations	-	1.0	-	0.0005	1.0	-	30	$\mu$ Adc
			-	2.0	-	0.001	2.0	-	60	
			-	4.0	-	0.002	4.0	-	120	

NOTES: <sup>1</sup> Remaining Static Electrical Characteristics are listed under "4000B Series Family Specifications".

<sup>2</sup>  $T_{LOW}$  = -55°C for C, D, F, H device.

= -40°C for E device.

$T_{HIGH}$  = +125°C for C, D, F, H device.

= + 85°C for E device.

**AC ELECTRICAL CHARACTERISTICS**

$T_A = 25^\circ\text{C}$ ,  $C_L = 50\text{ pF}$

PARAMETER	CONDITIONS	MIN	TYP	MAX	UNITS
$t_{PHL}$ , $t_{PLH}$	Propagation Delay Time Astable. Astable to OSC Out	$V_{DD} = 5V$ $V_{DD} = 10V$ $V_{DD} = 15V$	200 100 80	400 200 160	ns ns ns
$t_{PHL}$ , $t_{PLH}$	Astable, Astable to Q Q	$V_{DD} = 5V$ $V_{DD} = 10V$ $V_{DD} = 15V$	550 250 200	900 500 400	ns ns ns
$t_{PHL}$ , $t_{PLH}$	+ Trigger, - Trigger to Q Q	$V_{DD} = 5V$ $V_{DD} = 10V$ $V_{DD} = 15V$	700 300 240	1200 600 480	ns ns ns
$t_{PHL}$ , $t_{PLH}$	+ Trigger, Retrigger to Q Q	$V_{DD} = 5V$ $V_{DD} = 10V$ $V_{DD} = 15V$	300 175 150	600 300 250	ns ns ns
$t_{PHL}$ , $t_{PLH}$	Reset to Q Q	$V_{DD} = 5V$ $V_{DD} = 10V$ $V_{DD} = 15V$	300 125 100	500 250 200	ns ns ns
$t_{THL}$ , $t_{TLH}$	Transition Time Q, Q, OSC Out	$V_{DD} = 5V$ $V_{DD} = 10V$ $V_{DD} = 15V$	100 50 40	200 100 80	ns ns ns
$t_{WL}$ , $t_{WH}$	Minimum Input Pulse Duration	Any Input $V_{DD} = 5V$ $V_{DD} = 10V$ $V_{DD} = 15V$	500 200 160	1000 400 320	ns ns ns
$t_{RCL}$ , $t_{FCL}$	+ Trigger, Retrigger, Rise and Fall Time	$V_{DD} = 5V$ $V_{DD} = 10V$ $V_{DD} = 15V$		15 5 5	$\mu$ s $\mu$ s $\mu$ s
$C_{IN}$	Average Input Capacitance	Any Input	5	7.5	pF

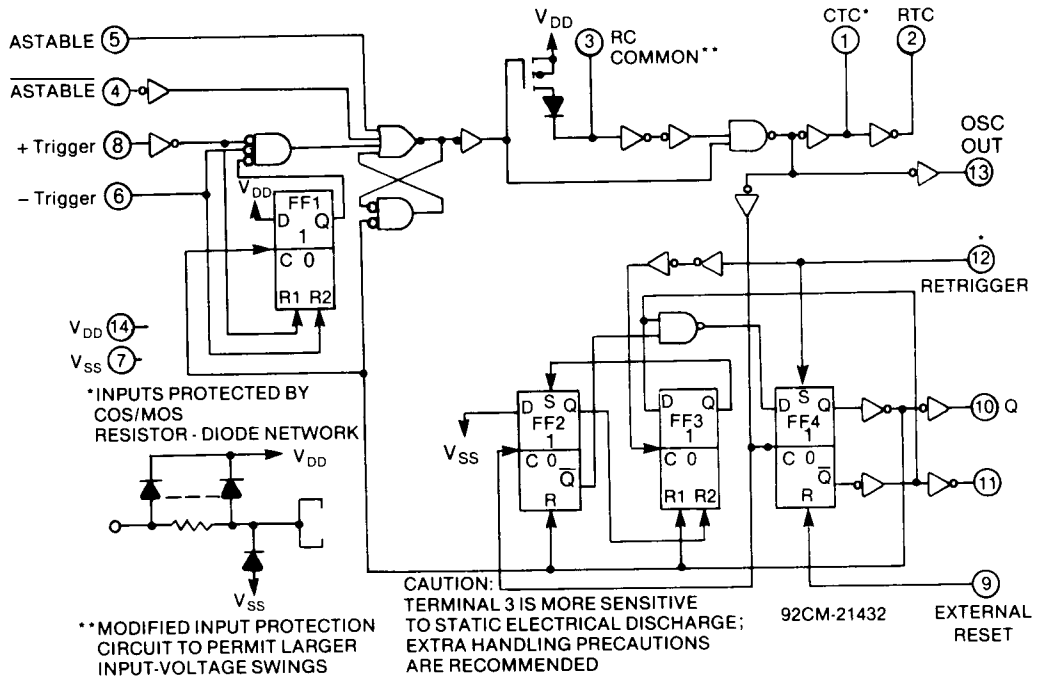

**TRUTH TABLE**

FUNCTION	TERMINAL CONNECTIONS			OUTPUT PULSE FROM	TYPICAL OUTPUT PERIOD OR PULSE WIDTH
	TO V <sub>DD</sub>	TO V <sub>SS</sub>	INPUT PULSE TO		
Astable Multivibrator	4, 5, 6, 14	7, 8, 9, 12		10, 11, 13	$t_A(10, 11) = 4.40 RC$
Free-Running	4, 6, 14	7, 8, 9, 12	5	10, 11, 13	
True Gating	6, 14	5, 7, 8, 9, 12	4	10, 11, 13	$t_A(13) = 2.20 RC$
Complement Gating					
Monostable Multivibrator	4, 14	5, 6, 7, 9, 12	8	10, 11	$t_M(10, 11) = 2.48 RC$
Positive-Edge Trigger	4, 8, 14	5, 7, 9, 12	6	10, 11	
Negative-Edge Trigger	4, 14	5, 6, 7, 9	8, 12	10, 11	
Retriggerable					
External Countdown*	14	5, 6, 7, 8, 9, 12	(See Figure)	(See Figure)	(See Figure)

Note: External resistor between terminals 2 and 3. External capacitor between terminals 1 and 3.

**\*Typical Implementation of External Countdown Option**

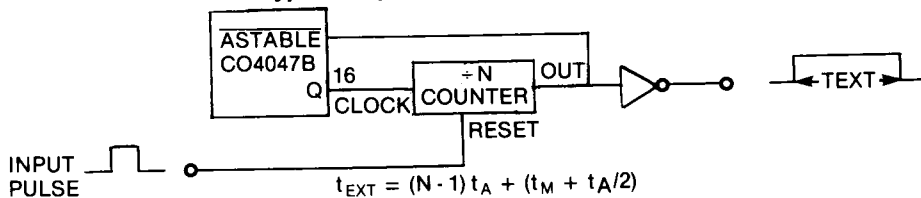

## TYPICAL PERFORMANCE CHARACTERISTICS

Typical Q,  $\bar{Q}$ , Osc Out Period Accuracy vs Supply Voltage (Astable Mode Operation)

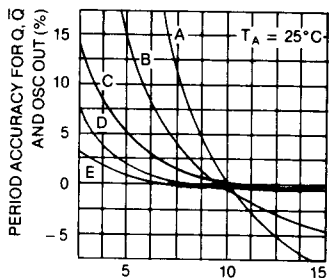

$V_{DD}$  — SUPPLY VOLTAGE (V)

	$f_{Q, \bar{Q}}$	R	C
A	1000 kHz	22k	10 pF
B	100 kHz	22k	100 pF
C	10 kHz	220k	100 pF
D	1 kHz	220k	1000 pF
E	100 Hz	2.2M	1000 pF

Typical Q,  $\bar{Q}$ , Pulse Width Accuracy vs Supply Voltage Monostable Mode Operation

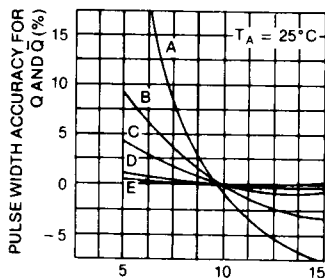

$V_{DD}$  — SUPPLY VOLTAGE (V)

	$t_M$	R	C
A	2 $\mu$ s	22K	10 pF
B	7 $\mu$ s	22k	100 pF
C	60 $\mu$ s	220k	100 pF
D	550 $\mu$ s	220k	1000 pF
E	5.5ms	2.2M	1000 pF

Typical Q,  $\bar{Q}$  and Osc Out Period Accuracy vs Temperature Astable Mode Operation

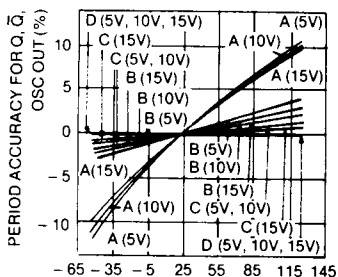

$T_A$  — AMBIENT TEMPERATURE (°C)

	$f_{Q, \bar{Q}}$	R	C
A	1000 kHz	22k	10 pF
B	100 kHz	22k	100 pF
C	10 kHz	220k	100 pF
D	1 kHz	220k	1000 pF

Typical Q and  $\bar{Q}$  Pulse Width Accuracy vs Temperature Monostable Mode Operation

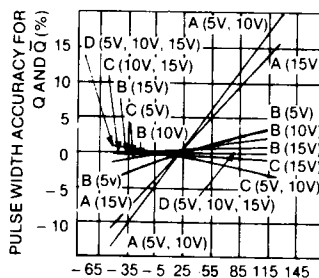

$T_A$  — TEMPERATURE (°C)

	$t_M$	R	C
A	2 $\mu$ s	22K	10 pF
B	7 $\mu$ s	22k	100 pF
C	60 $\mu$ s	220k	100 pF
D	550 $\mu$ s	220k	1000 pF

## TIMING DIAGRAMS

