

## 8-Bit Digital-to-Analog Converter with Two-Wire Interface

### FEATURES

- 8-Bit Digital-Analog Converter
- 8-Pin SOIC and 8-Pin MSOP Packages
- 2.7–5.5V Single-Supply Operation
- Simple SMBUS/I<sup>2</sup>C Serial Interface
- Low Power - 0.35mA Operation, 5µA Shutdown
- Guaranteed Monotonicity

### TYPICAL APPLICATIONS

- Programmable Voltage Sources
- Digital-Controlled Amplifiers/Attenuators
- Process Monitoring and Control
- Microprocessor- controlled systems

### GENERAL DESCRIPTION

The TC1320 is a serially accessible 8-bit voltage output digital-to-analog converter (DAC). The DAC produces an output voltage that ranges from ground to an externally supplied reference voltage. It operates from a single power supply that can range from 2.7V to 5.5V, making it ideal for a wide range of applications. Built into the part is a power-on reset function that ensures that the device starts at a known condition.

Communication with the TC1320 is accomplished via a simple 2-wire SMBus/I<sup>2</sup>C compatible serial port with the TC1320 acting as a slave only device. The host can enable the SHDN bit in the CONFIG register to activate the low-power standby mode.

### PIN CONFIGURATION

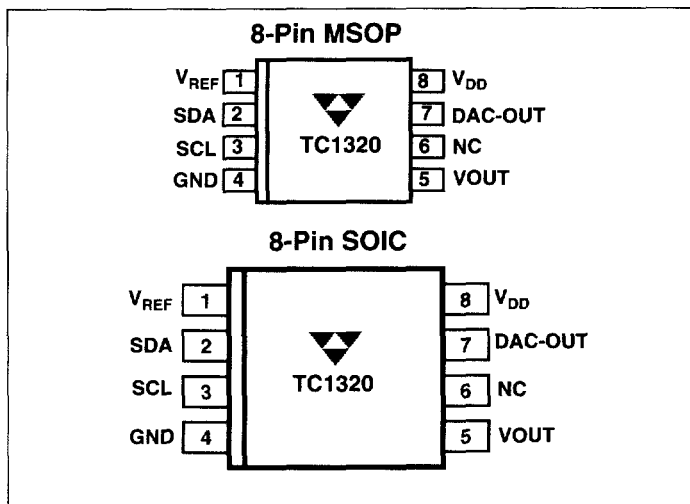

### ORDERING INFORMATION

Part No.	Package	Temp. Range
TC1320VOA	8-Pin SOIC	-40°C to +85°C
TC1320VUA	8-Pin MSOP	-40°C to +85°C

### FUNCTIONAL BLOCK DIAGRAM

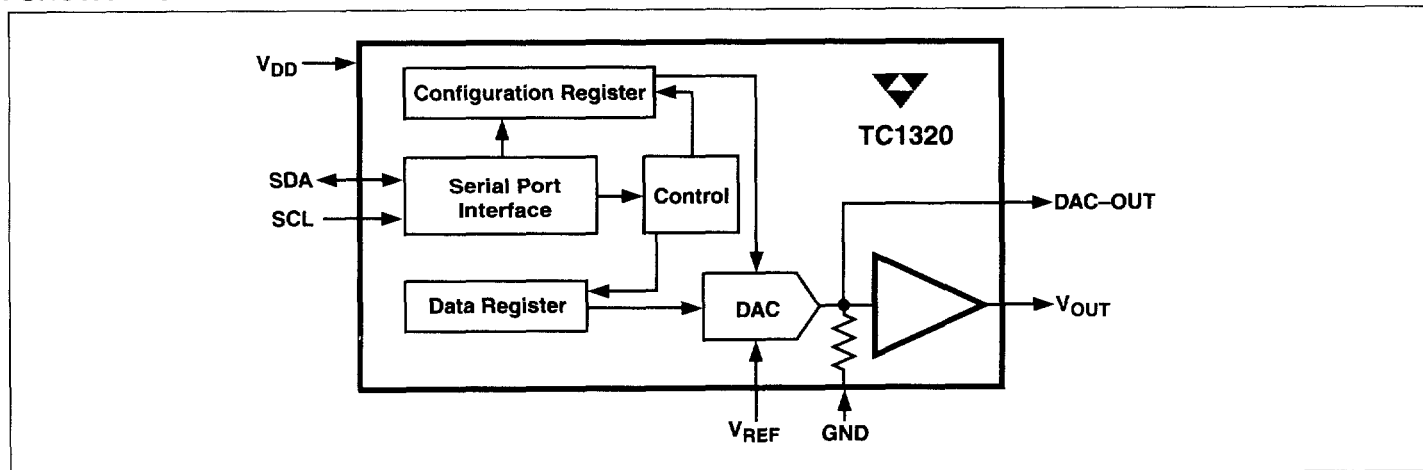

# PART III

## New Product Data Sheets

### 8-Bit Digital-to-Analog Converter with Two-Wire Interface

TC1320

PRELIMINARY INFORMATION

#### ABSOLUTE MAXIMUM RATINGS\*

Supply Voltage ( $V_{DD}$ )	+6V
Voltage On Any Pin	(GND – 0.3V) to ( $V_{DD} + 0.3V$ )
Operating Temperature ( $T_A$ )	See Below
Storage Temperature ( $T_{STG}$ )	– 65°C to +150°C
Current On Any Pin	±50 mA
Package Thermal Resistance ( $\theta_{JA}$ )	330°C/W

\*Static-sensitive device. Unused devices must be stored in conductive material. Protect devices from static discharge and static fields. Stresses above those listed under Absolute Maximum Ratings may cause permanent damage to the device. These are stress ratings only and functional operation of the device at these or any other conditions above those indicated in the operational sections of the specifications is not implied. Exposure to Absolute Maximum Rating Conditions for extended periods may affect device reliability.

**ELECTRICAL CHARACTERISTICS:**  $V_{DD} = 2.7V$  or  $5.5V$ ,  $-40^\circ C \leq T_A \leq 125^\circ C$ , unless otherwise noted.

Symbol	Parameter	Test Conditions	Min	Typ	Max	Unit
<b>Power Supply</b>						
$V_{DD}$	Supply Voltage		2.7	—	5.5	V
$I_{DD}$	Operating Current	$V_{DD} = 5.5V$ , $V_{REF} = 1.2V$ Serial Port Inactive (Note 1)	—	0.35	0.5	mA
$I_{DD-STANDBY}$	Standby Supply Current	$V_{DD} = 3.3V$ Serial Port Inactive (Note 1)	—	5	10	μA

**STATIC PERFORMANCE—ANALOG SECTION:** ( $V_{DD} = 2.7V$  to  $5.5V$ ,  $V_{REF} = 1.2V$ ,  $-40^\circ C \leq T_A \leq 85^\circ C$ , unless otherwise noted.)

Symbol	Parameter	Test Conditions	Min	Typ	Max	Unit
	Resolution		8	—	—	Bits
INL	Integral Non-Linearity at FS Error (Gain Error)	$-40^\circ C \leq T_A \leq 85^\circ C$ (Note2)	—	—	±2	LSB
DNL	Differential Non-Linearity	All Codes (Note 2)	—	—	±0.8	LSB
$V_{OS}$	Offset Error at $V_{OUT}$	(Note 2)		±0.3	±8	mV
$TCV_{OS}$	Offset Error Tempco at $V_{OUT}$			6		ppm/°C
PSRR	Power Supply Rejection Ratio	$V_{DD}$ at DC	70	—	—	dB
$V_{REF}$	Voltage Reference Range		0	—	$V_{DD} - 1.2$	V
$I_{REF}$	Reference Input Leakage Current				0.5	μA
$V_{SW}$	Voltage Swing	$V_{REF} \leq (V_{DD} - 1.2V)$	0		$V_{REF}$	V
$R_{OUT}$	Output Resistance @ $V_{OUT}$	$R_{OUT}$ (ohmic)	—	—	5.0	
$I_{OUT}$	Output Current (Source or Sink)		3	—	—	mA
$I_{SC}$	Output Short-Circuit Current	Source Sink	—	—	40	mA
			—	—	40	mA

**NOTES:** 1. SDA and SCL must be connected to  $V_{DD}$  or GND.  
2. Measured at  $V_{OUT} \geq 50mV$  referred to GND to avoid output buffer clipping.

**PRELIMINARY INFORMATION**

**TC1320**

**DYNAMIC PERFORMANCE:** ( $V_{DD} = 2.7V$  to  $5.5V$ ,  $-40^{\circ}C \leq T_A \leq 85^{\circ}C$ , unless otherwise noted.)

Symbol	Parameter	Test Conditions	Min	Typ	Max	Unit
SR	Voltage Output Slew Rate		—	0.8	—	V/ $\mu$ s
t <sub>SETTLE</sub>	Output Voltage Full Scale Settling Time		—	10	—	$\mu$ sec
t <sub>WU</sub>	Wake-up Time		—	20	—	$\mu$ s
	Digital Feedthrough and Crosstalk	SDA = V <sub>DD</sub> , SCL = 100kHz	—	5	—	nV-s

**SERIAL PORT INTERFACE:** ( $V_{DD} = 2.7V$  to  $5.5V$ ,  $-40^{\circ}C \leq T_A \leq 85^{\circ}C$ , unless otherwise noted.)

Symbol	Parameter	Test Conditions	Min	Typ	Max	Unit
V <sub>IH</sub>	Logic Input High		2.4	—	5.5	V
V <sub>IL</sub>	Logic Input Low		—	—	0.6	V
V <sub>OL</sub>	SDA Output Low	I <sub>OL</sub> = 3 mA (Sinking Current)	—	—	0.4	V
		I <sub>OL</sub> = 6 mA	—	—	0.6	V
C <sub>IN</sub>	Input Capacitance SDA, SCL		—	5	—	pF
I <sub>LEAK</sub>	I/O Leakage		—	—	±5	$\mu$ A

**SERIAL PORT AC TIMING:**  $V_{DD} = 2.7V$  or  $5.5V$ ,  $-40^{\circ}C \leq (T_A = T_J) \leq 85^{\circ}C$ ; C<sub>L</sub> = 80pF, unless otherwise noted.)

Symbol	Parameter	Test Conditions	Min	Typ	Max	Unit
f <sub>SMB</sub>	SMBus Clock Frequency		10	—	100	kHz
t <sub>IDLE</sub>	Bus Free Time Prior to New Transition		4.7	—	—	$\mu$ sec
t <sub>H(START)</sub>	Start Condition Hold Time		4.0	—	—	$\mu$ sec
t <sub>SU(START)</sub>	Start Condition Setup Time	90% SCL to 10% SDA (for repeated Start Condition)	4.7	—	—	$\mu$ sec
t <sub>SU(STOP)</sub>	Stop Condition Setup Time		4.0	—	—	$\mu$ sec
t <sub>H-DATA</sub>	Data In Hold Time		100	—	—	nsec
t <sub>SU-DATA</sub>	Data In Setup Time		100	—	—	nsec
t <sub>LOW</sub>	Low Clock Period	10% to 10%	4.7	—	—	$\mu$ sec
t <sub>HIGH</sub>	High Clock Period	90% to 90%	4	—	—	$\mu$ sec
t <sub>F</sub>	SMBus Fall Time	90% to 10%	—	—	300	nsec
t <sub>R</sub>	SMBus Rise Time	10% to 90%	—	—	1000	nsec
t <sub>POR</sub>	Power-On Reset Delay	V <sub>DD</sub> ≥ V <sub>POR</sub> (Rising Edge)	—	500	—	$\mu$ sec

**PIN DESCRIPTION**

Pin No.	Symbol	Type	Description
1	V <sub>REF</sub>	Input	Voltage Reference Input
2	SDA	Bi-Directional	SMBUS Serial Data
3	SCL	Input	SMBUS Serial Clock
4	GND	Input	System Ground
5	VOUT	Output	Buffered DAC Output
6	NC	None	Not Connected
7	DAC_OUT	Output	Unbuffered DAC Output
8	V <sub>DD</sub>	Power	Positive Power Supply Input

# PART III

## New Product Data Sheets

# 10-Bit Digital-to-Analog Converter with Two-Wire Interface

TC1320

PRELIMINARY INFORMATION

### TIMING DIAGRAMS

