



Obsolescence Notice

This product is obsolete.

This information is available for your convenience only.

For more information on Zarlink's obsolete products and replacement product lists, please visit http://products.zarlink.com/obsolete_products/

SL3227

3GHz NPN TRANSISTOR ARRAYS

The SL3227 is a monolithic array of the five high frequency low current NPN transistors in a 16 lead DIL package. The transistors exhibit typical f_T of 3GHz and wideband noise figures of 2dB. The SL3227 is pin compatible with the CA3127 and SL3127.

FEATURES

- f_T Typically 3GHz
- Wideband Noise Figure 2.0dB
- V_{BE} Matching Better Than 5mV

APPLICATIONS

- Wide Band Amplifiers
- PCM Regenerators
- High Speed Interface Circuits
- High Performance Instrumentation Amplifiers
- High Speed Modems

ABSOLUTE MAXIMUM RATINGS

The absolute maximum ratings are limiting values above which operating life may be shortened or specified parameters may be degraded.

All electrical ratings apply to individual transistors. Thermal ratings apply to the total package.

The isolation pin (substrate) must be connected to the most negative voltage applied to the package to maintain electrical isolation.

$V_{CB} = 10$ volt

$V_{EB} = 2.5$ volt

$V_{CE} = 6$ volt

$V_{CI} = 15$ volt

$I_C = 20$ mA

Maximum individual transistor dissipation 200 mWatt

Storage temperature -55°C to $+150^{\circ}\text{C}$

Max junction temperature $+150^{\circ}\text{C}$

Package thermal resistance ($^{\circ}\text{C}/\text{watt}$)

Package Type	MP16
Chip to case	111
Chip to ambient	41

NOTE: If all the power is being dissipated in one transistor, these thermal resistance figures should be increased by $100^{\circ}\text{C}/\text{watt}$

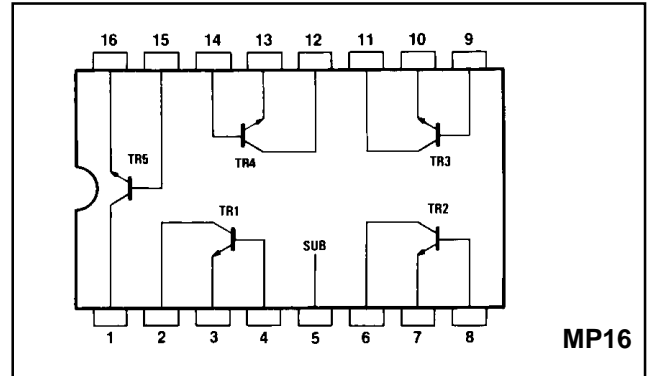

Fig.1 Pin connections - SL3227

ORDERING INFORMATION

SL3227 NA MP

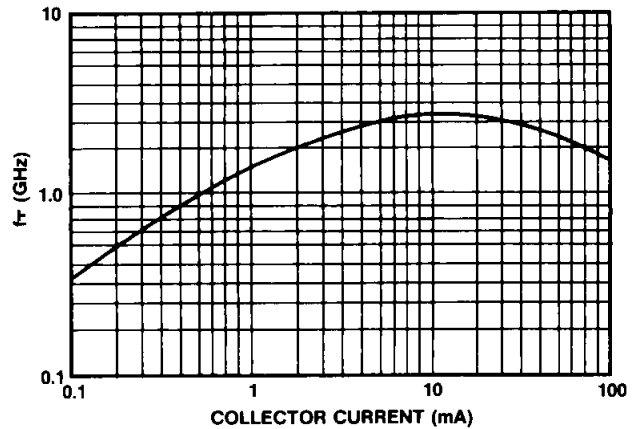

Fig.2 Transition frequency (f_T) v. collector current
($V_{CB} = 2\text{V}$, $f = 200\text{MHz}$)

ELECTRICAL CHARACTERISTICS

These characteristics are guaranteed over the following test conditions (unless otherwise stated)

$$T_{amb} = 22^{\circ}\text{C} \pm 2^{\circ}\text{C}$$

Static Characteristics

Characteristic	Symbol	Value			Units	Conditions
		Min.	Typ.	Max.		
Collector base breakdown	BV_{CBO}	10	20		V	$I_C = 10\mu\text{A}$
Collector isolation breakdown	BV_{CIO}	16	40		V	$I_C = 10\mu\text{A}$
Base emitter breakdown	BV_{EBO}	2.5	5.0		V	$I_E = 10\mu\text{A}$
Collector emitter breakdown	LV_{CEO}	6	9		V	$I_C = 5\text{mA}$
Collector emitter saturation voltage	$V_{CE(SAT)}$		0.22	0.5	V	$I_C = 10\text{mA}, I_B = 1\text{mA}$
Base emitter voltage	V_{BE}	0.73	0.78	0.81	V	$V_{CE} = 2\text{V}, I_C = 1\text{mA}$
Base emitter voltage difference, all transistors	ΔV_{BE}		0.45	5.0	mV	$V_{CE} = 2\text{V}, I_C = 1\text{mA}$
Input offset current	ΔI_B		0.2	3	μA	$V_{CE} = 2\text{V}, I_C = 1\text{mA}$
Temperature coefficient of V_{BE}	$\frac{\Delta V_{BE}}{T}$		-1.69		mV/ $^{\circ}\text{C}$	$V_{CE} = 2\text{V}, I_C = 1\text{mA}$
Static forward current ratio	H_{fe}	35 35 40	80 95 85			$V_{CE} = 2\text{V}, I_C = 5\text{mA}$ $V_{CE} = 2\text{V}, I_C = 0.1\text{mA}$ $V_{CE} = 2\text{V}, I_C = 1\text{mA}$
Emitter base leakage	I_{EBO}		15		nA	$V_{EB} = 2\text{V}$
Collector base leakage	I_{CBO}		5		pA	$V_{CB} = 10\text{V}$
Collector isolation leakage	I_{CIO}		5		pA	$V_{CI} = 16\text{V}$
Emitter base capacitance	C_{EB}		0.7		pF	$V_{EB} = 0\text{V}$
Collector base capacitance	C_{CB}		0.4		pF	$V_{CI} = 0\text{V}$
Collector isolation capacitance	C_{CI}		1.5	2.0	pF	$V_{CI} = 0\text{V}$

Dynamic Characteristics

Characteristic	Symbol	Value			Units	Conditions
		Min.	Typ.	Max.		
Transition frequency	f_T		3		GHz	$V_{CE} = 2\text{V}, I_C = 5\text{mA}$
Wideband noise figure	NF		2.0		dB	$f = 60\text{MHz}$ $V_{CC} = 6\text{V}$
Knee of NF noise curve			1		KHz	$I_C = 1\text{mA}$ $R_s = 1\text{k}\Omega$



HEADQUARTERS OPERATIONS
GEC PLESSEY SEMICONDUCTORS
 Cheney Manor, Swindon,
 Wiltshire SN2 2QW, United Kingdom.
 Tel: (0793) 518000
 Fax: (0793) 518411

GEC PLESSEY SEMICONDUCTORS
 P.O. Box 660017
 1500 Green Hills Road,
 Scotts Valley, California 95067-0017,
 United States of America.
 Tel: (408) 438 2900
 Fax: (408) 438 5576

CUSTOMER SERVICE CENTRES

- **FRANCE & BENELUX** Les Ulis Cedex Tel: (1) 64 46 23 45 Fax : (1) 64 46 06 07
- **GERMANY** Munich Tel: (089) 3609 06-0 Fax : (089) 3609 06-55
- **ITALY** Milan Tel: (02) 66040867 Fax: (02) 66040993
- **JAPAN** Tokyo Tel: (03) 5276-5501 Fax: (03) 5276-5510
- **NORTH AMERICA** Scotts Valley, USA Tel (408) 438 2900 Fax: (408) 438 7023.
- **SOUTH EAST ASIA** Singapore Tel: (65) 3827708 Fax: (65) 3828872
- **SWEDEN** Stockholm, Tel: 46 8 702 97 70 Fax: 46 8 640 47 36
- **UK, EIRE, DENMARK, FINLAND & NORWAY**
 Swindon Tel: (0793) 518510 Fax : (0793) 518582

These are supported by Agents and Distributors in major countries world-wide.

© GEC Plessey Semiconductors 1994

This publication is issued to provide information only which (unless agreed by the Company in writing) may not be used, applied or reproduced for any purpose nor form part of any order or contract nor to be regarded as a representation relating to the products or services concerned. No warranty or guarantee express or implied is made regarding the capability, performance or suitability of any product or service. The Company reserves the right to alter without prior knowledge the specification, design or price of any product or service. Information concerning possible methods of use is provided as a guide only and does not constitute any guarantee that such methods of use will be satisfactory in a specific piece of equipment. It is the user's responsibility to fully determine the performance and suitability of any equipment using such information and to ensure that any publication or data used is up to date and has not been superseded. These products are not suitable for use in any medical products whose failure to perform may result in significant injury or death to the user. All products and materials are sold and services provided subject to the Company's conditions of sale, which are available on request.



**For more information about all Zarlink products
visit our Web Site at
www.zarlink.com**

Information relating to products and services furnished herein by Zarlink Semiconductor Inc. trading as Zarlink Semiconductor or its subsidiaries (collectively "Zarlink") is believed to be reliable. However, Zarlink assumes no liability for errors that may appear in this publication, or for liability otherwise arising from the application or use of any such information, product or service or for any infringement of patents or other intellectual property rights owned by third parties which may result from such application or use. Neither the supply of such information or purchase of product or service conveys any license, either express or implied, under patents or other intellectual property rights owned by Zarlink or licensed from third parties by Zarlink, whatsoever. Purchasers of products are also hereby notified that the use of product in certain ways or in combination with Zarlink, or non-Zarlink furnished goods or services may infringe patents or other intellectual property rights owned by Zarlink.

This publication is issued to provide information only and (unless agreed by Zarlink in writing) may not be used, applied or reproduced for any purpose nor form part of any order or contract nor to be regarded as a representation relating to the products or services concerned. The products, their specifications, services and other information appearing in this publication are subject to change by Zarlink without notice. No warranty or guarantee express or implied is made regarding the capability, performance or suitability of any product or service. Information concerning possible methods of use is provided as a guide only and does not constitute any guarantee that such methods of use will be satisfactory in a specific piece of equipment. It is the user's responsibility to fully determine the performance and suitability of any equipment using such information and to ensure that any publication or data used is up to date and has not been superseded. Manufacturing does not necessarily include testing of all functions or parameters. These products are not suitable for use in any medical products whose failure to perform may result in significant injury or death to the user. All products and materials are sold and services provided subject to Zarlink's conditions of sale which are available on request.

Purchase of Zarlink's I²C components conveys a licence under the Philips I²C Patent rights to use these components in and I²C System, provided that the system conforms to the I²C Standard Specification as defined by Philips.

Zarlink and the Zarlink Semiconductor logo are trademarks of Zarlink Semiconductor Inc.

Copyright 2001, Zarlink Semiconductor Inc. All Rights Reserved.

TECHNICAL DOCUMENTATION - NOT FOR RESALE
