

CD54/74HC4040
CD54/74HCT4040

File Number 1483

HARRIS SEMICONDUCTOR

27E D 4302271 0017895 5 HAS

High-Speed CMOS Logic

12-Stage Binary Counter

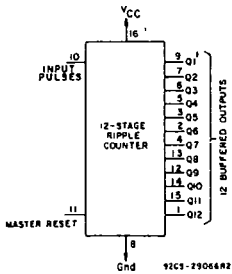

Type Features:

- Fully static operation
- Buffered inputs
- Common reset
- Negative edge pulsing
- Typical $I_{MAX} = 50 \text{ MHz} @ V_{CC} = 5 \text{ V}, C_L = 15 \text{ pF}, T_A = 25^\circ \text{ C}$

FUNCTIONAL DIAGRAM

The RCA-CD54/74HC4040 and CD54/74HCT4040 are 12-stage ripple-carry binary counters. All counter stages are master-slave flip-flops. The state of the stage advances one count on the negative transition of each input pulse; a high voltage level on the MR line resets all stages to their zero state. All inputs and outputs are buffered.

The CD54HC4040 and CD54HCT4040 are supplied in 16-lead hermetic dual-in-line ceramic packages (F suffix). The CD74HC4040 and CD74HCT4040 are supplied in 16-lead dual-in-line plastic packages (E suffix) and in 16-lead dual-in-line surface mount plastic package (M suffix). Both types are also available in chip form (H suffix).

Family Features:

- Fanout (Over Temperature Range):
Standard Outputs - 10 LSTTL Loads
Bus Driver Outputs - 15 LSTTL Loads
- Wide Operating Temperature Range:
CD74HC/HCT: -40 to $+85^\circ \text{ C}$
- Balanced Propagation Delay and Transition Times
- Significant Power Reduction Compared to LSTTL Logic ICs
- Alternate Source is Philips/Sigmetics
- CD54HC/CD74HC Types:
2 to 6 V Operation
High Noise Immunity: $N_{IL}=30\%, N_{IH}=30\%$ of V_{CC} @ $V_{CC}=5 \text{ V}$
- CD54HCT/CD74HCT Types:
4.5 to 5.5 V Operation
Direct LSTTL Input Logic Compatibility
 $V_{IL}=0.8 \text{ V Max.}, V_{IH}=2 \text{ V Min.}$
CMOS Input Compatibility
 $I_i \leq 1 \mu\text{A} @ V_{OL}, V_{OH}$

TRUTH TABLE

| ϕ | MR | Output State |
|--------|----|-----------------------|
| | L | No Change |
| | L | Advance to next state |
| X | H | All Outputs are low |

H = high level (steady state)
L = low level (steady state)
X = don't care

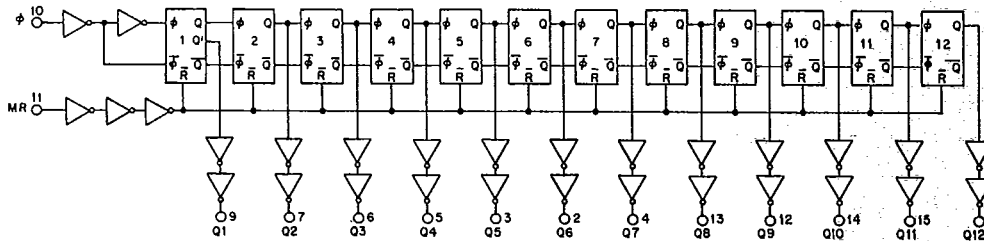

Fig. 1 - Logic block diagram.

92CL-37015R3

CD54/74HC4040 CD54/74HCT4040

MAXIMUM RATINGS, Absolute-Maximum Values:

| | |
|-------------------------------------------------------------------------------------------------------------------|--------------------------------------|
| DC SUPPLY-VOLTAGE, (V _{cc}): | |
| (Voltages referenced to ground) | -0.5 to +7 V |
| DC INPUT DIODE CURRENT, I _{IK} (FOR V _i < -0.5 V OR V _i > V _{cc} + 0.5V) | ±20mA |
| DC OUTPUT DIODE CURRENT, I _{OK} (FOR V _o < -0.5 V OR V _o > V _{cc} + 0.5V) | ±20mA |
| DC DRAIN CURRENT, PER OUTPUT (I _o) (FOR -0.5 V < V _o < V _{cc} + 0.5V) | ±25mA |
| DC V _{cc} OR GROUND CURRENT (I _{cc}) | ±50mA |
| POWER DISSIPATION PER PACKAGE (P _o): | |
| For T _A = -40 to +60°C (PACKAGE TYPE E) | 500 mW |
| For T _A = +60 to +85°C (PACKAGE TYPE E) | Derate Linearly at 8 mW/°C to 300 mW |
| For T _A = -55 to +100°C (PACKAGE TYPE F, H) | 500 mW |
| For T _A = +100 to +125°C (PACKAGE TYPE F, H) | Derate Linearly at 8 mW/°C to 300 mW |
| For T _A = -40 to +70°C (PACKAGE TYPE M) | 400 mW |
| For T _A = +70 to +125°C (PACKAGE TYPE M) | Derate Linearly at 8 mW/°C to 70 mW |
| OPERATING-TEMPERATURE RANGE (T _A): | |
| PACKAGE TYPE F, H | -55 to +125°C |
| PACKAGE TYPE E, M | -40 to +85°C |
| STORAGE TEMPERATURE (T _{stg}) | -65 to +150°C |
| LEAD TEMPERATURE (DURING SOLDERING): | |
| At distance 1/16 ± 1/32 in. (1.59 ± 0.79 mm) from case for 10 s max. | +265°C |
| Unit inserted into a PC Board (min. thickness 1/16 in., 1.59 mm) | |
| with solder contacting lead tips only | +300°C |

RECOMMENDED OPERATING CONDITIONS:

For maximum reliability, nominal operating conditions should be selected so that operation is always within the following ranges:

| CHARACTERISTIC | LIMITS | | UNITS |
|------------------------------------------------------------------------------------------------|--------|-----------------|-------|
| | MIN. | MAX. | |
| Supply-Voltage Range (For T _A =Full Package Temperature Range) V _{cc} * | | | |
| CD54/74HC Types | 2 | 6 | V |
| CD54/74HCT Types | 4.5 | 5.5 | V |
| DC Input or Output Voltage V _{in} , V _{out} | 0 | V _{cc} | V |
| Operating Temperature T _A : | | | |
| CD74 Types | -40 | +85 | °C |
| CD54 Types | -55 | +125 | °C |
| Input Rise and Fall Times t _r , t _f | | | |
| at 2 V | 0 | 1000 | ns |
| at 4.5 V | 0 | 500 | ns |
| at 6 V | 0 | 400 | ns |

*Unless otherwise specified, all voltages are referenced to Ground.

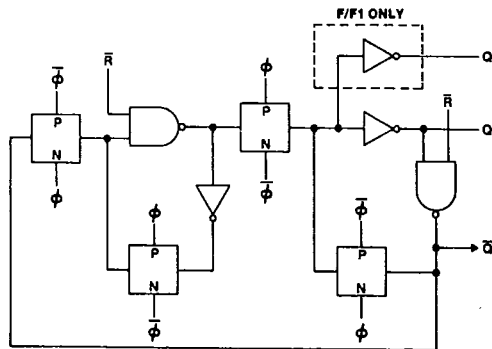

Fig. 2 - Detail for flip-flops 1, 2, 4, 5, 7, 8, 10 & 11.

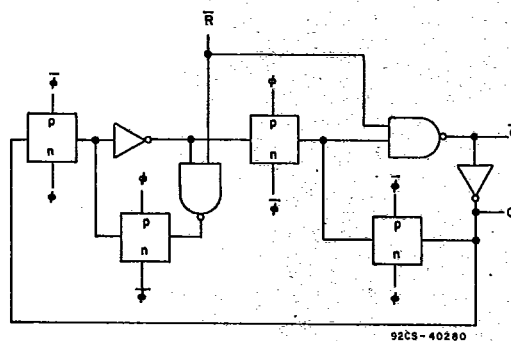

Fig. 3 - Detail for flip-flops 3, 6, 9 & 12.

HARRIS SEMICONDUCTOR SECTOR 27E D 430227J 0017896 ? HAS

CD54/74HC4040
CD54/74HCT4040

STATIC ELECTRICAL CHARACTERISTICS

| CHARACTERISTIC | CD74HC4040/CD54HC4040 | | | | | | | | | | CD74HCT4040/CD54HCT4040 | | | | | | | | | | UNITS | | | | |
|----------------------------------------------------------------------------------|------------------------------------------|----------------------|----------------------|-----------------|-----|------|------------|------|------|------------|-------------------------------------------|------------|---------------------|----------------------|-------------------|------|------|-------------|-----|-----|-------|-------------|---|---|---|
| | TEST CONDITIONS | | | 74HC/54HC TYPES | | | 74HC TYPES | | | 54HC TYPES | | | TEST CONDITIONS | | 74HCT/54HCT TYPES | | | 74HCT TYPES | | | | 54HCT TYPES | | | |
| | V _i V | I _o mA | V _{cc} V | +25°C | | | -40/+85°C | | | -55/+125°C | | | V _i V | V _{cc} V | +25°C | | | -40/+85°C | | | | -55/+125°C | | | |
| | | | | Min | Typ | Max | Min | Max | Min | Max | Min | Max | | | Min | Typ | Max | Min | Max | Min | | Max | | | |
| High-Level Input Voltage V _{ih} | | | 2 | 1.5 | — | — | 1.5 | — | 1.5 | — | — | 4.5 | | | 2 | — | — | 2 | — | 2 | — | — | V | | |
| | | | 4.5 | 3.15 | — | — | 3.15 | — | 3.15 | — | — | 5.5 | | | — | — | — | — | — | — | — | — | — | — | |
| | | | 6 | 4.2 | — | — | 4.2 | — | 4.2 | — | — | — | | | — | — | — | — | — | — | — | — | — | — | — |
| Low-Level Input Voltage V _{il} | | | 2 | — | — | 0.5 | — | 0.5 | — | 0.5 | — | 4.5 | | | 2 | — | — | 0.8 | — | 0.8 | — | 0.8 | — | V | |
| | | | 4.5 | — | — | 1.35 | — | 1.35 | — | 1.35 | — | — | | | — | — | — | — | — | — | — | — | — | — | — |
| | | | 6 | — | — | 1.8 | — | 1.8 | — | 1.8 | — | — | | | — | — | — | — | — | — | — | — | — | — | — |
| High-Level Output Voltage V _{oh} | V _{ih} or CMOS Loads | -0.02 | 2 | 1.9 | — | — | 1.9 | — | 1.9 | — | V _{ih} | 4.5 | 4.4 | — | — | 4.4 | — | 4.4 | — | 4.4 | — | — | V | | |
| | | | 4.5 | 4.4 | — | — | 4.4 | — | 4.4 | — | — | | | — | — | — | — | — | — | — | — | — | — | — | |
| | | | 6 | 5.9 | — | — | 5.9 | — | 5.9 | — | V _{ih} | | | — | — | — | — | — | — | — | — | — | — | — | — |
| TTL Loads | V _{ih} or V _{oh} | -4 -5.2 | 4.5 | 3.98 | — | — | 3.84 | — | 3.7 | — | or | 4.5 | 3.98 | — | — | 3.84 | — | 3.7 | — | — | — | V | | | |
| | | | 6 | 5.48 | — | — | 5.34 | — | 5.2 | — | V _{oh} | — | — | — | — | — | — | — | — | — | — | — | | | |
| | | | — | — | — | — | — | — | — | — | — | — | — | — | — | — | — | — | — | — | — | — | — | | |
| Low-Level Output Voltage V _{ol} | V _{ih} or CMOS Loads | 0.02 | 2 | — | — | 0.1 | — | 0.1 | — | 0.1 | V _{ih} | 4.5 | — | — | — | 0.1 | — | 0.1 | — | 0.1 | — | — | V | | |
| | | | 4.5 | — | — | 0.1 | — | 0.1 | — | 0.1 | — | | | — | — | — | — | — | — | — | — | — | — | — | |
| | | | 6 | — | — | 0.1 | — | 0.1 | — | 0.1 | — | | | V _{ih} | — | — | — | — | — | — | — | — | — | — | — |
| TTL Loads | V _{ih} or V _{oh} | 4 5.2 | 4.5 | — | — | 0.26 | — | 0.33 | — | 0.4 | or | 4.5 | — | — | 0.26 | — | 0.33 | — | 0.4 | — | — | V | | | |
| | | | 6 | — | — | 0.26 | — | 0.33 | — | 0.4 | — | — | — | — | — | — | — | — | — | — | — | — | | | |
| | | | — | — | — | — | — | — | — | — | — | — | — | — | — | — | — | — | — | — | — | — | — | | |
| Input Leakage Current I _i | V _{cc} or Gnd | | 6 | — | — | ±0.1 | — | ±1 | — | ±1 | Any Voltage Between V _{cc} & Gnd | 5.5 | — | — | ±0.1 | — | ±1 | — | ±1 | — | — | μA | | | |
| Quiescent Device Current I _{cc} | V _{cc} or Gnd | 0 | 6 | — | — | 8 | — | 80 | — | 160 | V _{cc} or Gnd | 5.5 | — | — | 8 | — | 80 | — | 160 | — | — | μA | | | |
| Additional Quiescent Device Current per input pin 1 unit load ΔI _{cc} * | | | | | | | | | | | V _{cc} -2.1 | 4.5 5.5 | to | — | 100 | 360 | — | 450 | — | 490 | — | μA | | | |

*For dual-supply systems theoretical worst case (V_i = 2.4 V, V_{cc} = 5.5 V) specification is 1.8 mA.

HCT Input Loading Table

| Input | Unit Loads* |
|-------|-------------|
| MR | 0.65 |
| φ | 0.5 |

*Unit Load is ΔI_{cc} limit specified in Static Characteristic Chart, e.g., 360 μA max. @ 25°C.

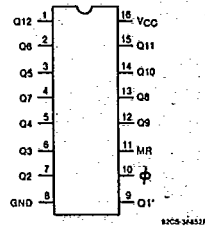

TERMINAL ASSIGNMENT

HARRIS SEMICONDUCTOR 27E D 430227J 0017897 9 HAS

CD54/74HC4040
CD54/74HCT4040

SWITCHING CHARACTERISTICS ($V_{CC} = 5\text{ V}$, $T_A = 25^\circ\text{C}$, Input $t_r, t_f = 6\text{ ns}$)

| CHARACTERISTIC | SYMBOL | C_L pF | Typical | | |
|----------------------------------------|------------------------|-------------|---------|-----|-------|
| | | | HC | HCT | Units |
| Propagation Delay ϕ to Q1' Output | t_{PLH} t_{PHL} | 15 | 11 | 17 | ns |
| Propagation Delay Q_n to Q_{n+1} | t_{PHL} t_{PHL} | 15 | 4 | 4 | ns |
| Propagation Delay to MR to Q_n | t_{PHL} | 15 | 14 | 17 | ns |
| Power Dissipation Capacitance* | C_{PD} | — | 40 | 45 | pF |

* C_{PD} is used to determine the power consumption, per package.

PD = $C_{PD} V_{CC}^2 f_i + \sum (C_L V_{CC}^2 f_i / M)$ where:

$M = 2^1, 2^2, 2^3, \dots, 2^{i-1}$

C_L = output load capacitance

f_i = input frequency

Pre-requisite for Switching Function

| CHARACTERISTIC | SYMBOL | V_{CC} | 25°C | | | | -40°C to +85°C | | | | -55°C to +125°C | | | | UNITS |
|-------------------------------|-----------|----------|------|------|------|------|----------------|------|-------|------|-----------------|------|-------|------|-------|
| | | | HC | | HCT | | 74HC | | 74HCT | | 54HC | | 54HCT | | |
| | | | Min. | Max. | Min. | Max. | Min. | Max. | Min. | Max. | Min. | Max. | Min. | Max. | |
| Maximum Input Pulse Frequency | f_{MAX} | 2 | 6 | — | — | 5 | — | — | — | 4 | — | — | — | MHz | |
| | | 4.5 | 30 | — | 25 | 25 | — | 20 | — | 20 | — | 16 | — | | |
| | | 6 | 35 | — | — | 29 | — | — | — | 24 | — | — | — | | |
| Input Pulse Width (Figure 4) | t_w | 2 | 80 | — | — | 100 | — | — | — | 120 | — | — | — | ns | |
| | | 4.5 | 16 | — | 20 | 20 | — | 25 | — | 24 | — | 30 | — | | |
| | | 6 | 14 | — | — | 17 | — | — | — | 20 | — | — | — | | |
| Reset Removal Time (Figure 5) | t_{REM} | 2 | 50 | — | — | 65 | — | — | — | 75 | — | — | — | ns | |
| | | 4.5 | 10 | — | 10 | 13 | — | 13 | — | 15 | — | 15 | — | | |
| | | 6 | 9 | — | — | 11 | — | — | — | 13 | — | — | — | | |
| Reset Pulse Width (Figure 5) | t_w | 2 | 80 | — | — | 100 | — | — | — | 120 | — | — | — | ns | |
| | | 4.5 | 16 | — | 20 | 20 | — | 25 | — | 24 | — | 30 | — | | |
| | | 6 | 14 | — | — | 17 | — | — | — | 20 | — | — | — | | |

SWITCHING CHARACTERISTICS ($C_L=50\text{ pF}$, Input $t_r, t_f=6\text{ ns}$)

| CHARACTERISTIC | SYMBOL | V_{CC} | 25°C | | | | -40°C to +85°C | | | | -55°C to +125°C | | | | UNITS |
|---------------------------------------------------|------------------------|----------|------|------|------|------|----------------|------|-------|------|-----------------|------|-------|------|-------|
| | | | HC | | HCT | | 74HC | | 74HCT | | 54HC | | 54HCT | | |
| | | | Min. | Max. | Min. | Max. | Min. | Max. | Min. | Max. | Min. | Max. | Min. | Max. | |
| Propagation Delay ϕ to Q1' Output (Figure 4) | t_{PLH} t_{PHL} | 2 | — | 140 | — | — | 175 | — | — | — | 210 | — | — | ns | |
| | | 4.5 | — | 28 | — | 40 | — | 35 | — | 50 | — | 42 | — | | 60 |
| | | 6 | — | 24 | — | — | 30 | — | — | — | 36 | — | — | | — |
| Propagation Delay Q_n to Q_{n+1} (Figure 4) | t_{PLH} t_{PHL} | 2 | — | 75 | — | — | 95 | — | — | — | 110 | — | — | ns | |
| | | 4.5 | — | 15 | — | 15 | — | 19 | — | 19 | — | 22 | — | | 22 |
| | | 6 | — | 13 | — | — | 16 | — | — | — | 19 | — | — | | — |
| Propagation Delay MR to Q_n (Figure 5) | t_{PHL} | 2 | — | 170 | — | — | 215 | — | — | — | 255 | — | — | ns | |
| | | 4.5 | — | 34 | — | 40 | — | 43 | — | 50 | — | 51 | — | | 60 |
| | | 6 | — | 29 | — | — | 37 | — | — | — | 43 | — | — | | — |
| Output Transition Time (Figure 4) | t_{TLH} t_{THL} | 2 | — | 75 | — | — | 95 | — | — | — | 110 | — | — | ns | |
| | | 4.5 | — | 15 | — | 15 | — | 19 | — | 19 | — | 22 | — | | 22 |
| | | 6 | — | 13 | — | — | 16 | — | — | — | 19 | — | — | | — |
| Input Capacitance | C_i | | — | 10 | — | 10 | — | 10 | — | 10 | — | 10 | pF | | |

HARRIS SEMICONDUCTOR 27E D 4302271 0017898 0 HAS

CD54/74HC4040
CD54/74HCT4040

HARRIS SEMICONDUCTOR

27E D

4302271 0017899 2 HAS

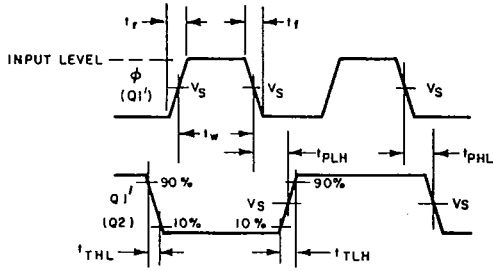

| | 54/74 HC | 54/74 HCT |
|----------------|-----------------|-----------|
| INPUT LEVEL | V _{CC} | 3V |
| V _S | 50% | 1.3V |

92CS-37017

Fig. 4 - Input pulse pre-requisite times, propagation delays and output transition times.

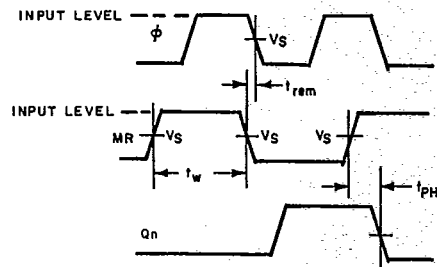

| | 54/74 HC | 54/74 HCT |
|----------------|---------------------|-----------|
| INPUT LEVEL | V _{CC} | 3V |
| V _S | 50% V _{CC} | 1.3V |

92CS-37018RI

Fig. 5 - Master Reset pre-requisite and propagation delays.