

Low Phase Noise VCXO (20MHz to 52MHz)

FEATURES

- Integrated voltage-controlled crystal oscillator circuitry (VCXO) (pull range 380ppm minimum).
- VCXO tuning range: 0V - V_{DD} .
- Uses inexpensive fundamental-mode parallel resonant crystals (from 20 to 52MHz).
- 2.5V or 3.3V supply voltage.
- Selectable High Drive (30mA) or Standard Drive (10mA) CMOS output.
- Available in 8-Pin SOIC or TSSOP.

PIN CONFIGURATION

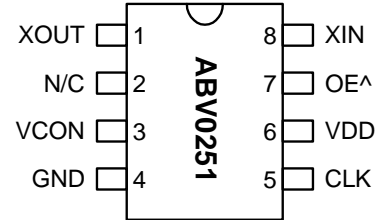

Note: ^ denotes internal pull up

DESCRIPTION

The ABV0251 is a monolithic low jitter, high performance CMOS VCXO IC. It allows control of the output frequency with an input voltage (VCON), using a low cost crystal. This makes the ABV0251 ideal for a wide range of applications from 20MHz to 52MHz (including 27MHz, 35.328MHz, etc.).

OUTPUT RANGE

MULTIPLIER	FREQUENCY RANGE	OUTPUT BUFFER
No PLL	20 - 52MHz	CMOS

BLOCK DIAGRAM

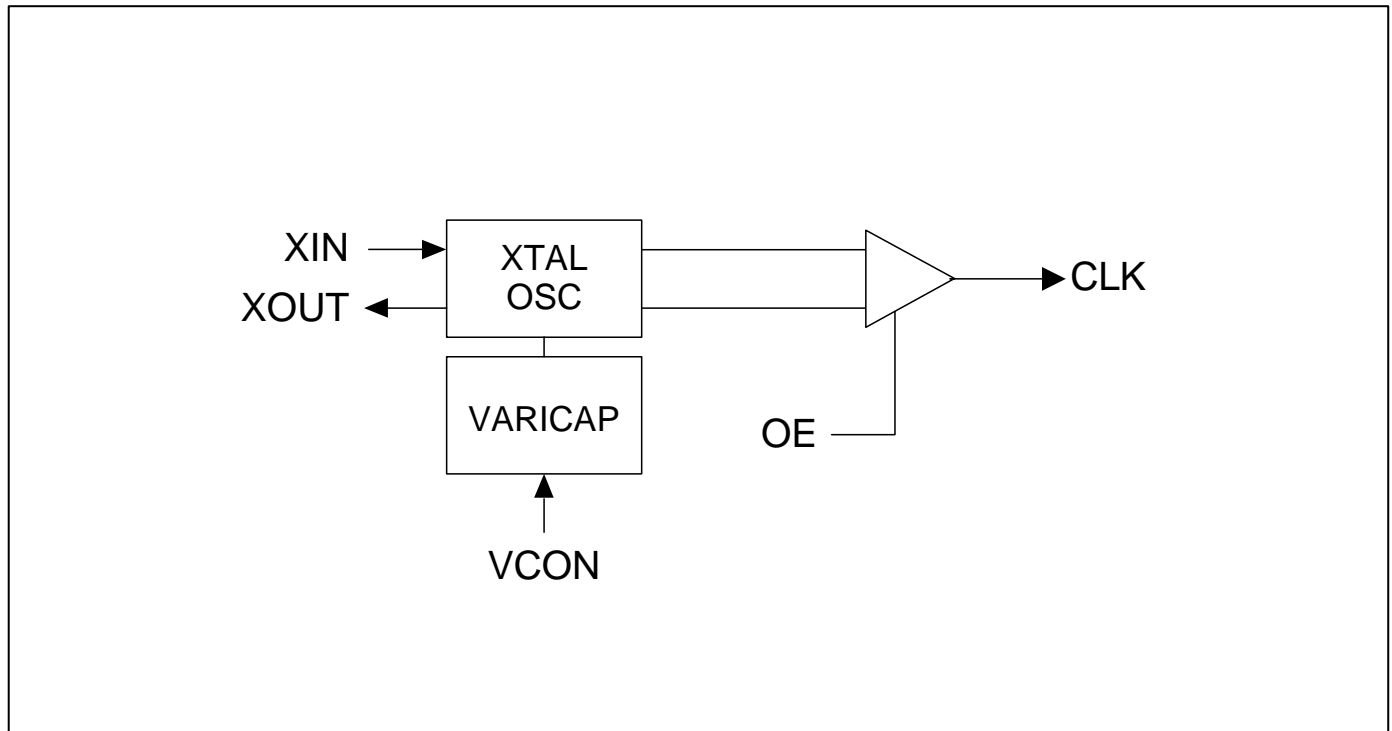

Low Phase Noise VCXO (20MHz to 52MHz)

PIN DESCRIPTIONS

Name	Number	Type	Description
XOUT	1	I	Crystal output. See Crystal Specification on page 4.
N/C	2	-	Not connected.
VCON	3	I	Voltage Control input.
GND	4	P	Ground.
CLK	5	O	Output clock.
VDD	6	P	Power supply.
OE	7	I	Output enable input. Disables (tri-state) output when low. Internal pull-up enables output by default if pin is not connected to low.
XIN	8	I	Crystal input. See Crystal Specification on page 4.

ELECTRICAL SPECIFICATIONS

1. Absolute Maximum Ratings

PARAMETERS	SYMBOL	MIN.	MAX.	UNITS
Supply Voltage	V_{DD}		4.6	V
Input Voltage, dc	V_i	-0.5	$V_{DD}+0.5$	V
Output Voltage, dc	V_o	-0.5	$V_{DD}+0.5$	V
Storage Temperature	T_s	-65	150	°C
Ambient Operating Temperature*	T_A	-40	85	°C
Junction Temperature	T_J		125	°C
Lead Temperature (soldering, 10s)			260	°C
ESD Protection, Human Body Model			2	kV

Exposure of the device under conditions beyond the limits specified by Maximum Ratings for extended periods may cause permanent damage to the device and affect product reliability. These conditions represent a stress rating only, and functional operations of the device at these or any other conditions above the operational limits noted in this specification is not implied.

* Note: Operating Temperature is guaranteed by design for all parts (COMMERCIAL and INDUSTRIAL), but tested for COMMERCIAL grade only.

2. DC Electrical Specifications

PARAMETERS	SYMBOL	CONDITIONS	MIN.	TYP.	MAX.	UNITS
Supply Current, Dynamic, with Loaded Outputs	I_{DD}	$F_{XIN} = 20 - 52\text{MHz}$ Output load of 10pF		10		mA
Operating Voltage	V_{DD}		2.25		3.63	V
Output drive current (High Drive)	I_{OH}	$V_{OH} = V_{DD}-0.4V, V_{DD}=3.3V$	30			mA
	I_{OL}	$V_{OL} = 0.4V, V_{DD} = 3.3V$	30			mA
Output drive current (Standard Drive)	I_{OH}	$V_{OH} = V_{DD}-0.4V, V_{DD}=3.3V$	10			mA
	I_{OL}	$V_{OL} = 0.4V, V_{DD} = 3.3V$	10			mA
Short Circuit Current				±50		mA
VCXO Control Voltage	VCON		0		V_{DD}	V

Low Phase Noise VCXO (20MHz to 52MHz)

3. AC Electrical Specifications

PARAMETERS	SYMBOL	CONDITIONS	MIN.	TYP.	MAX.	UNITS
Input Crystal Frequency			20		52	MHz
Output Clock Rise/Fall Time (Standard Drive)		0.3V ~ 3.0V with 15 pF load		2.4		ns
Output Clock Rise/Fall Time (High Drive)		0.3V ~ 3.0V with 15 pF load		1.2		
Output Clock Duty Cycle		Measured @ 50% V _{DD}	45	50	55	%

4. Voltage Control Crystal Oscillator (3.3V)

PARAMETERS	SYMBOL	CONDITIONS	MIN.	TYP.	MAX.	UNITS
VCXO Stabilization Time *	T _{VCXOSTB}	From power valid			10	ms
VCXO Tuning Range		F _{XIN} = 20 - 52MHz; XTAL C ₀ /C ₁ < 250 0V ≤ VCON ≤ 3.3V		500		ppm
CLK output pullability		VCON=1.65V ±1.65V	±200			ppm
VCXO Tuning Characteristic				150		ppm/V
Pull range linearity					10	%
VCON input impedance				80		kΩ
VCON modulation BW		0V ≤ VCON ≤ 3.3V, -3dB	25			kHz

Note: Parameters denoted with an asterisk (*) represent nominal characterization data and are not production tested to any specific limits.

5. Jitter Specifications

PARAMETERS	CONDITIONS	MIN.	TYP.	MAX.	UNITS
Period jitter RMS	35.328 MHz		2.3		ps
Period jitter peak-to-peak	35.328MHz		18		ps
Integrated jitter RMS	Integrated 12 kHz to 20 MHz at 35.328MHz		1		ps

6. Phase Noise Specifications

PARAMETERS	FREQUENCY	@10Hz	@100Hz	@1kHz	@10kHz	@100kHz	UNITS
Phase Noise relative to carrier	51.85MHz	-65	-90	-120	-140	-147	dBc/Hz

Note: Phase Noise at VCON = 0V

Low Phase Noise VCXO (20MHz to 52MHz)

7. Crystal Specifications

PARAMETERS	SYMBOL	CONDITIONS	MIN.	TYP.	MAX.	UNITS
Crystal Resonator Frequency	F_{XIN}	Parallel Fundamental Mode	20		52	MHz
Crystal Loading Rating	$C_L (xtal)$	At $V_{con} = 1.65V$		9.5		pF
Crystal Pullability	$C_0/C_1 (xtal)$	AT cut			250	-
Recommended ESR	R_E	AT cut			30	Ω

Note: Crystal Loading rating: 9.5pF is the loading the crystal sees from the VCXO chip at $V_{CON} = 1.65V$. It is assumed that the crystal will be at nominal frequency at this load. If the crystal requires more load to be at nominal frequency, the additional load must be added externally. This however may reduce the pull range

PACKAGE INFORMATION

8 PIN (dimensions in mm)

Symbol	Narrow SOIC		TSSOP	
	Min.	Max.	Min.	Max.
A	1.47	1.73	-	1.20
A1	0.10	0.25	0.05	0.15
B	0.33	0.51	0.19	0.30
C	0.19	0.25	0.09	0.20
D	4.80	4.95	2.90	3.10
E	3.80	4.00	4.30	4.50
H	5.80	6.20	6.20	6.60
L	0.38	1.27	0.45	0.75
e	1.27 BSC		0.65 BSC	

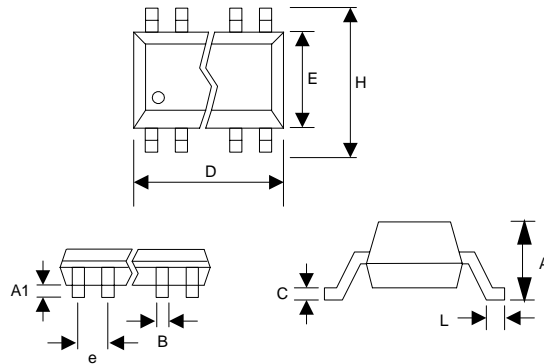

Low Phase Noise VCXO (20MHz to 52MHz)

ORDERING INFORMATION

For part ordering, please contact our Sales Department:

30332 Esperanza., Rancho Santa Margarita, Ca 92688

Ph: 949-546-8000 Fax: 949-546-8001

PART NUMBER

The order number for this device is a combination of the following:
Device number, Package type and Operating temperature range

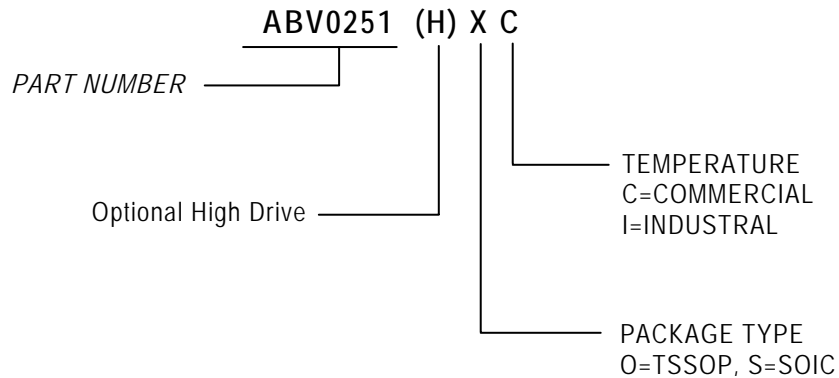

<u>Order Number</u>	<u>Marking</u>	<u>Package Option</u>
ABV0251OC-T	ABV0251OC	TSSOP - Tape and Reel
ABV0251OC	ABV0251OC	TSSOP - Tube
ABV0251HOC-T	ABV0251HOC	TSSOP - Tape and Reel
ABV0251HOC	ABV0251HOC	TSSOP - Tube
ABV0251SC-T	ABV0251SC	SOIC - Tape and Reel
ABV0251SC	ABV0251SC	SOIC - Tube
ABV0251HSC-T	ABV0251HSC	SOIC - Tape and Reel
ABV0251HSC	ABV0251HSC	SOIC - Tube

Abrakon Corporation, reserves the right to make changes in its products or specifications, or both at any time without notice. The information furnished by Abrakon is believed to be accurate and reliable. However, Abrakon makes no guarantee or warranty concerning the accuracy of said information and shall not be responsible for any loss or damage of whatever nature resulting from the use of, or reliance upon this product.

LIFE SUPPORT POLICY: Abrakon's products are not authorized for use as critical components in life support devices or systems without the express written approval of the President of Abrakon Corporation.