

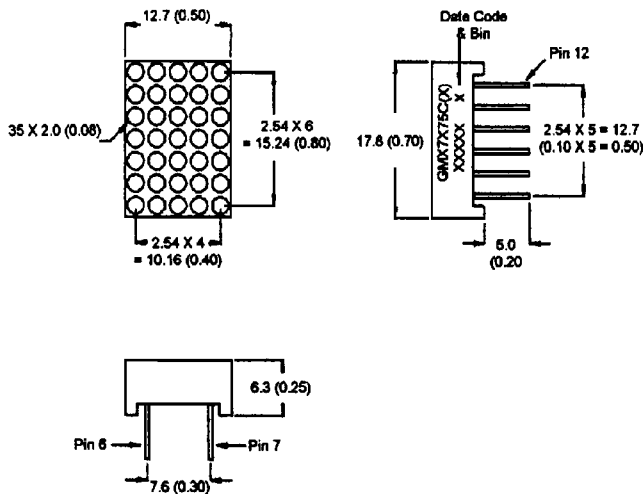

0.7 INCH (17.2mm) 5 X 7 DOT MATRIX STICK DISPLAY

Superbright Red GMX7275C
Superbright Red GMX7275CA

PACKAGE DIMENSIONS



DESCRIPTION

The GMX7275C(X) a 5 X 7, Superbright red dotmatrix display. Populated with GaAlAs/GaAs Single Hetero Junction LEDs, it has a grey face with white segment color.

FEATURES

- 0.7" (17.2mm) character height.
- Low power requirement.
- Wide 130° viewing angle.
- High brightness and contrast
- 5 X 7 array with X-Y select.
- X-Y stackable.
- Easy mounting on P.C. board.

NOTE: Dimensions are in mm (inch).
Tolerances are ± 0.25 (0.1) unless otherwise noted.
All pins are 0.5 (.02).

MODEL NUMBERS

<u>Part Number</u>	<u>Colour</u>	<u>Description</u>
GMA7275C	AlGaAs Red	Common anode row.
GMA7275CA	AlGaAs Red	Common anode row, alternate pin-out.
GMC7275C	AlGaAs Red	Common cathode row.
GMC7275CA	AlGaAs Red	Common cathode row, alternate pin-out.

(For other color options, contact your local area Sales Office)



0.7 INCH (17.2mm) 5 X 7 DOT MATRIX STICK DISPLAY

ABSOLUTE MAXIMUM RATING (T_A = 25°C unless otherwise specified)

	Superbright Red	Units
Peak forward current per segment (Duty cycle 1/10, 10KHz)	200	mA
Continous IF per segment	30	mA
Power dissipation per segment	100*	mW
*Derate linearly from 25°C	0.5	mW/°C
Reverse voltage VR per segment	5	Volts
Operating and storage temperature range.....	-25°C to +85°C	
Soldering time at 260°C..... (1/16" below seating plane)	3 sec	

ELECTRO - OPTICAL CHARACTERISTICS (T_A = 25°C unless otherwise specified)

	Superbright Red	Test Condition
Luminous Intensity/Dot Digit average (Typical)	5000ucd	I _F = 20 mA
Forward voltage (V _F) typical	1.8V	I _F = 20 mA
maximum	2.5V	I _F = 20 mA
Peak wavelength (nm)	660nm	I _F = 20 mA
Spectral line half width (nm)	20nm	I _F = 20mA
Reverse breakdown voltage V _R	5V	I _R = 100uA



0.7 INCH (17.2mm) 5 X 7 DOT MATRIX STICK DISPLAY

PIN CONNECTION:

GMX7X75C

GMA7X75C		GMC7X75C	
Pin Number	Function	Pin Number	Function
1	Anode Row 1	1	Cathode Row 1
2	Anode Row 2	2	Cathode Row 2
3	Cathode Column 2	3	Anode Column 2
4	Cathode Column 1	4	Anode Column 1
5	Anode Row 6	5	Cathode Row 6
6	Anode Row 7	6	Cathode Row 7
7	Cathode Column 3	7	Anode Column 3
8	Anode Row 5	8	Cathode Row 5
9	Cathode Column 4	9	Anode Column 4
10	Anode Row 4	10	Cathode Row 4
11	Anode Row 3	11	Cathode Row 3
12	Cathode Column 5	12	Anode Column 5

GMX7X75CA

GMC7X75CA		GMA7X75CA	
Pin Number	Function	Pin Number	Function
1	Anode Column 1	1	Cathode Column 1
2	Cathode Row 3	2	Anode Row 3
3	Anode Column 2	3	Cathode Column 2
4	Cathode Row 5	4	Anode Row 5
5	Cathode Row 6	5	Anode Row 6
6	Cathode Row 7	6	Anode Row 7
7	Anode Column 4	7	Cathode Column 3
8	Anode Column 5	8	Cathode Column 5
9	Cathode Row 4	9	Anode Row 4
10	Anode Column 3	10	Cathode Column 3
11	Cathode Row 2	11	Anode Row 2
12	Cathode Row 1	12	Anode Row 1

SCHEMATICS:

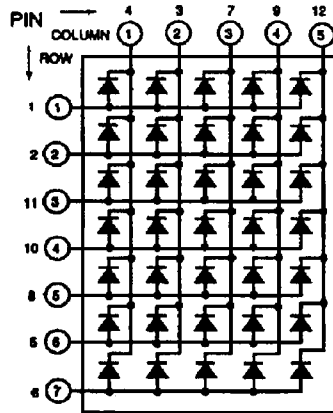

GMA7X75C

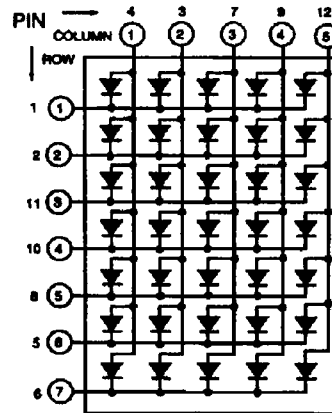

GMC7X75C

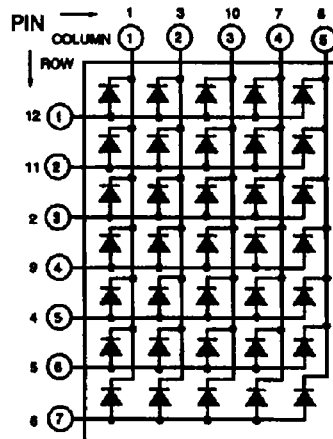

GMA7X75CA

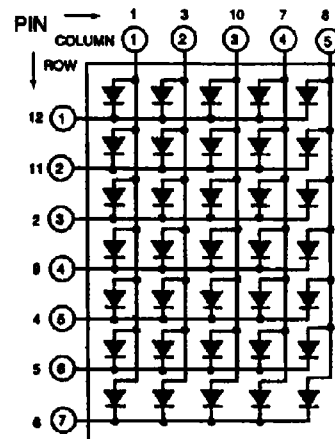

GMC7X75CA

GRAPHICAL DETAIL: AlGaAs Red ($T_A = 25^\circ\text{C}$ unless otherwise specified)

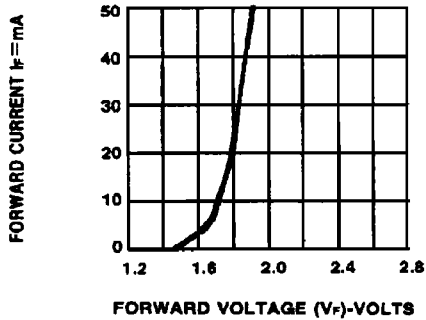

Fig.1 FORWARD CURRENT VS. FORWARD VOLTAGE.

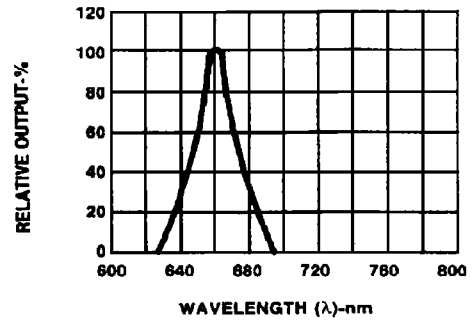

Fig.2 SPECTRAL RESPONSE

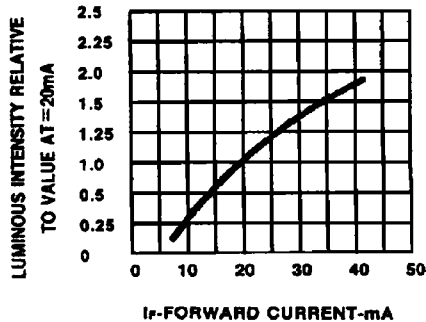

Fig.3 RELATIVE LUMINOUS INTENSITY VS. FORWARD CURRENT

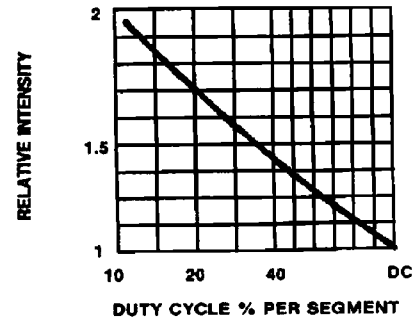

Fig.5 LUMINOUS INTENSITY VS. DUTY CYCLE

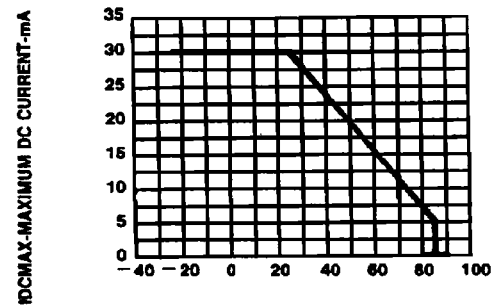

Fig.4 MAXIMUM ALLOWABLE DC CURRENT PER SEGMENT VS. A FUNCTION OF AMBIENT TEMPERATURE.

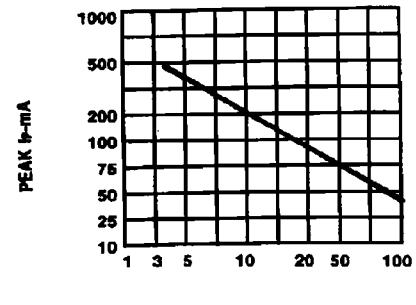

Fig.6 MAX PEAK CURRENT VS. DUTY CYCLE % (REFRESH RATE $f = 1 \text{ KHz}$)