

S7183

S7184

Linear current amplification of photodiode output

The S7183 and S7184 consist of a photodiode and a signal processing circuit for amplifying the photocurrent generated from the photodiode up to 1300 times. Despite a small active area, these photo ICs provide an output nearly equal to that from photodiodes with a 20 × 20 mm active area. Both S7183 and S7184 can be used the same way as a reverse-biased photodiode, and in most cases, they deliver a sufficient output voltage by just connecting a load resistor.

Features

- Clear plastic package
- Operation just as easy as using photodiodes
- Large output current rivaling that of a phototransistor
- Good linearity

Applications

- Energy saving sensors for TV brightness controls, etc.
- Light dimmers for liquid crystal panels
- Various types of light level measurement

Absolute maximum ratings (Ta=25 °C)

Parameter	Symbol	Condition	Value	Unit
Reverse voltage	VR		-0.5 to +16	V
Photocurrent	IL		10	mA
Forward current	IF		10	mA
Power dissipation*1	P		250	mW
Operating temperature	Topr	No dew condensation*2	-30 to +80	°C
Storage temperature	Tstg	No dew condensation*2	-40 to +85	°C
Soldering	S7183	-	260 °C, 3 s, at least 2.5 mm away from package surface	-
	S7184			350 °C, 3 s

Note: Exceeding the absolute maximum ratings even momentarily may cause a drop in product quality. Always be sure to use the product within the absolute maximum ratings.

*1: Power dissipation decreases at a rate of 3.3 mW/°C above Ta=25 °C

*2: When there is a temperature difference between a product and the surrounding area in high humidity environment, dew condensation may occur on the product surface. Dew condensation on the product may cause deterioration in characteristics and reliability.

Electrical and optical characteristics (Ta=25 °C)

Parameter	Symbol	Condition	Min.	Typ.	Max.	Unit
Spectral response range	λ		-	300 to 1000	-	nm
Peak sensitivity wavelength	λ_p		-	650	-	nm
Operating reverse voltage	VR		3	-	12	V
Dark current	ID	VR=5 V	-	0.5	10	nA
Photocurrent	IL	VR=5 V	0.75	1.0	1.25	mA
		2856 K	S7183, 100 lx S7184, 1000 lx	1.4	1.8	
Rise/fall times	tr, tf	10 to 90%,*3 VR=5 V, RL=10 k Ω λ =660 nm	-	0.6	-	ms

*3: Rise/fall time measurement method: Refer to P.2.

Rise/fall time measurement method

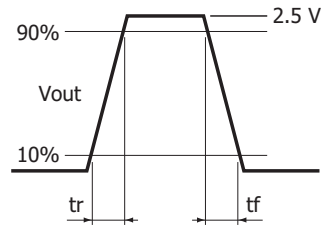
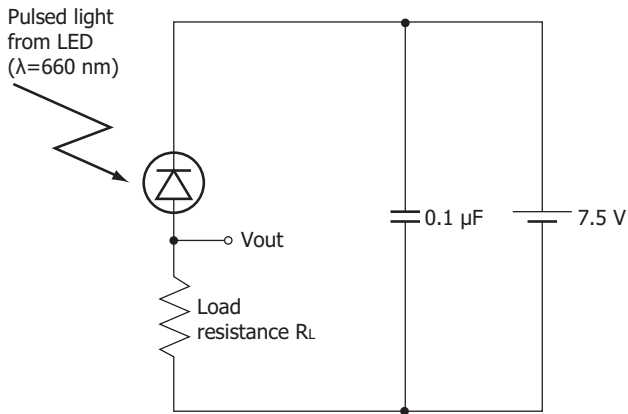

KPIC0041EB

Spectral response

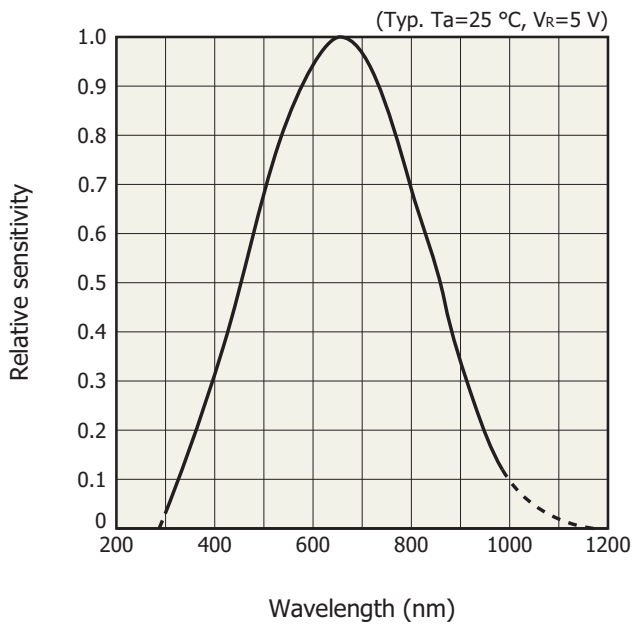

KPIC0036EA

Linearity

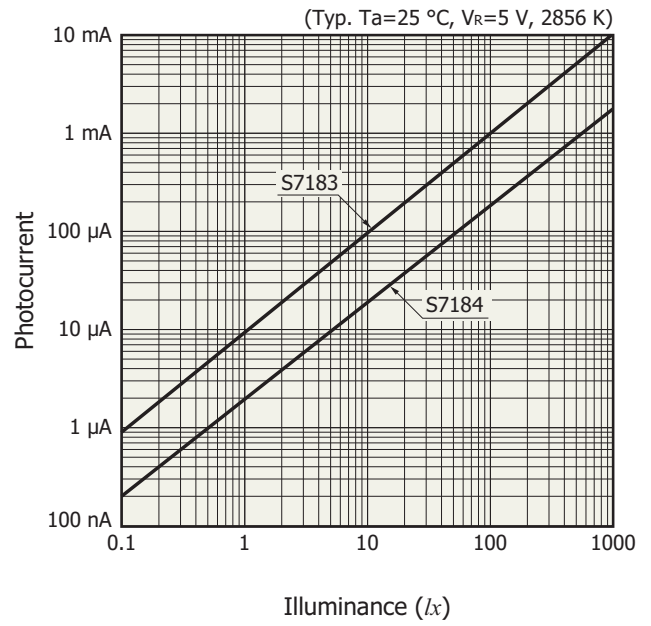

KPIC0178EA

Dark current vs. ambient temperature

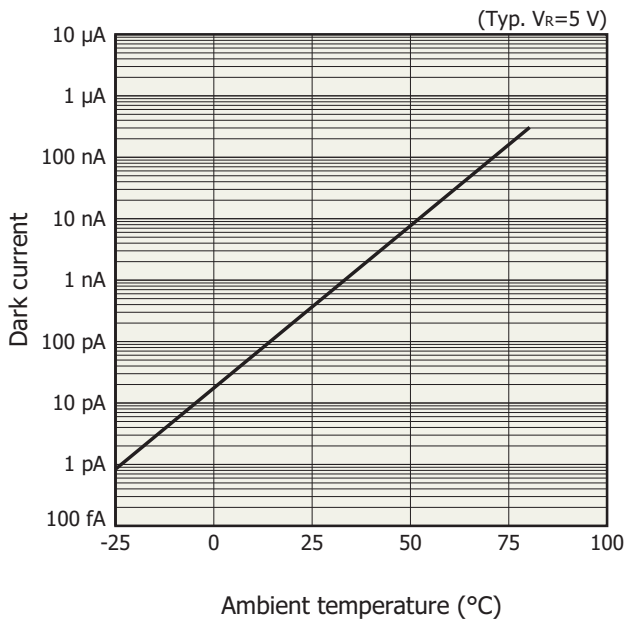

Rise/fall times vs. load resistance

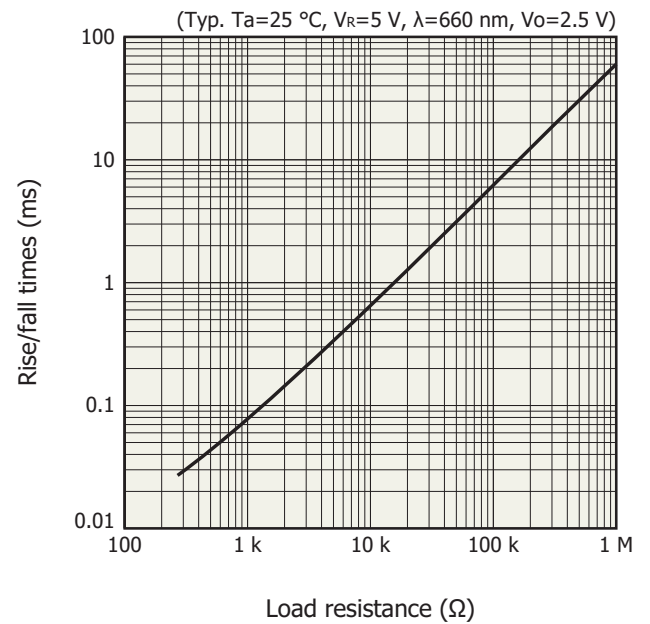

Directivity

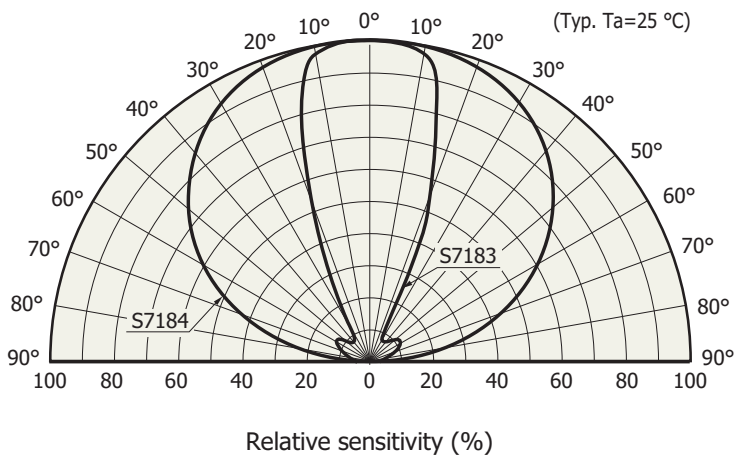

Operating circuit example

The drawing surrounded by the dotted line shows a schematic diagram of the photo IC.

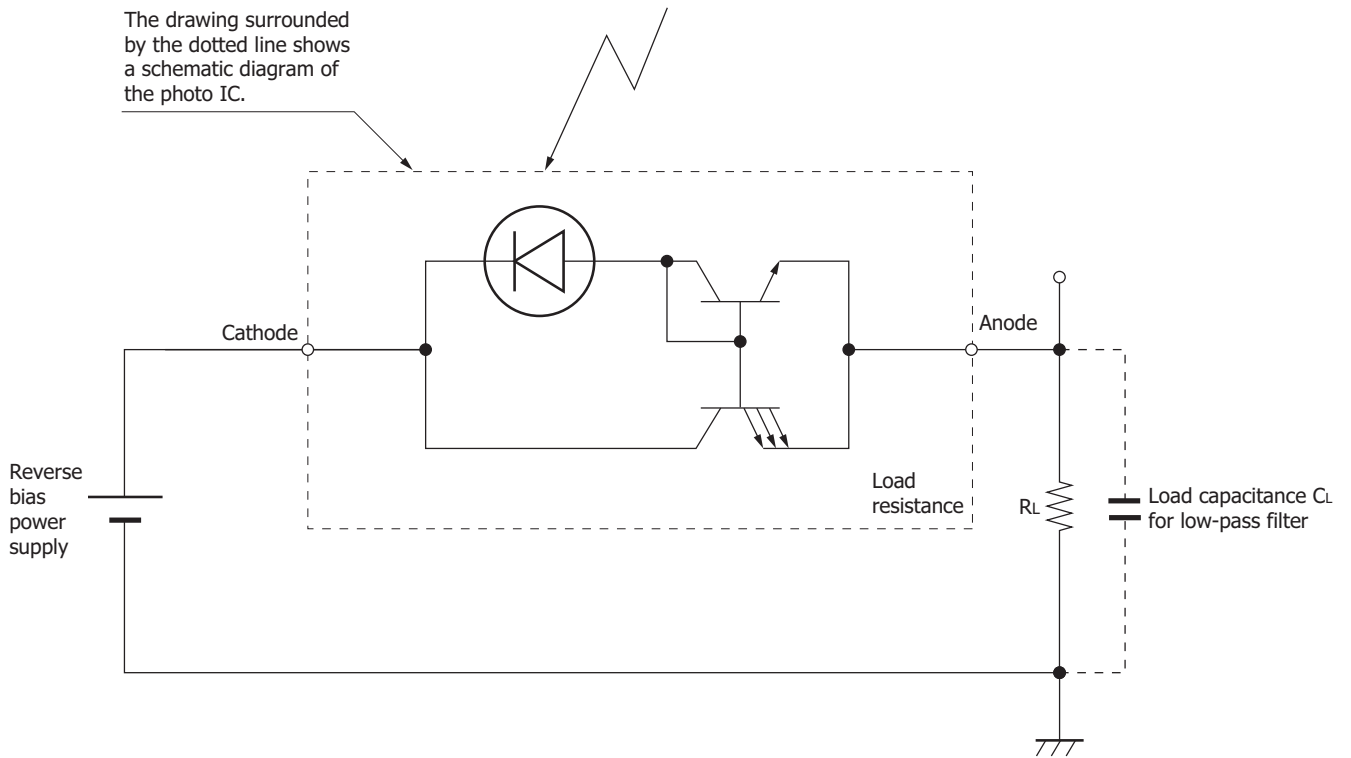

KPIC0018EA

The photodiode must be reverse-biased so that a positive potential is applied to the cathode. To eliminate high-frequency components, we recommend placing a load capacitance C_L in parallel with load resistance R_L as a low-pass filter.

$$\text{Cutoff frequency } (f_c) \approx \frac{1}{2\pi C_L R_L}$$

Dimensional outlines (unit: mm)

S7183

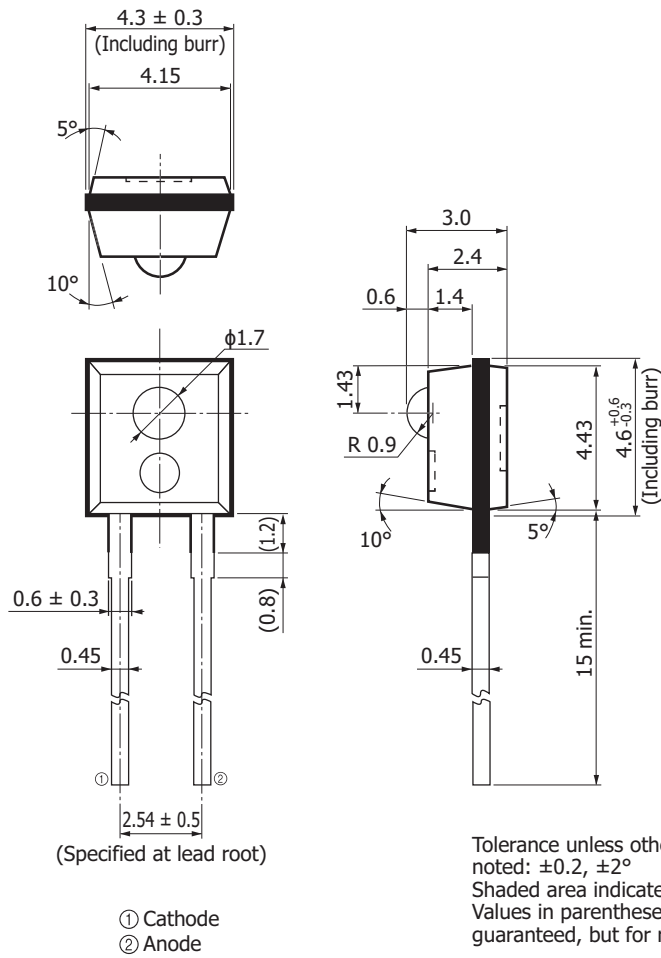

Tolerance unless otherwise noted: ± 0.2 , $\pm 2^\circ$
 Shaded area indicates burr.
 Values in parentheses are not guaranteed, but for reference.

Packing type: Polyethylene bag (antistatic type)

KPICA0017EC

S7184

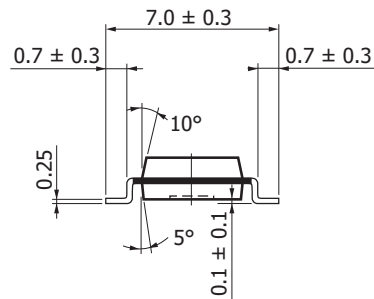
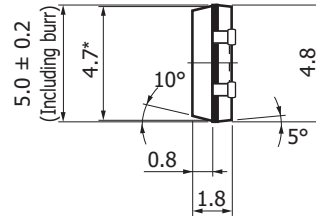
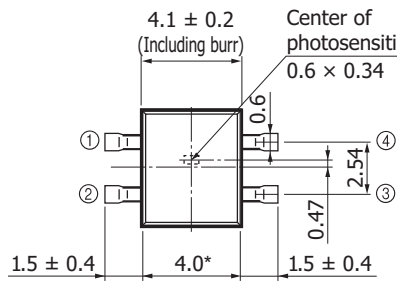

- ① Cathode
- ② (Anode)
- ③ Anode
- ④ (Anode)

Tolerance unless otherwise noted: ± 0.1 , $\pm 2^\circ$
 Shaded area indicates burr.
 Chip position accuracy with respect to the package dimensions marked *
 $X \leq \pm 0.25$, $Y \leq \pm 0.25$, $\theta \leq \pm 2^\circ$

Packing type: Stick

Pins ② and ④ must be connected to ③ on the PC board.

KPTCA0018ED

Operating voltage, output characteristics

Figure 2 shows the photocurrent vs. reverse voltage characteristics (light source: LED) for the measurement circuit example in Figure 1. The output curves are shown for illuminance levels. The output curves rise from a reverse voltage (rising voltage) of approximately 0.7 V ($\pm 10\%$).

To protect the photo IC diode from excessive current, a 150 Ω ($\pm 20\%$) protection resistor is inserted in the circuit. Reverse voltage V_R when the photo IC diode is saturated is the sum of $V_{be(ON)}$ and the voltage drop across the protection resistor R_{in} [Equation (1)].

$$V_R = V_{be(ON)} + I_L \times R_{in} \dots\dots\dots (1)$$

The photodiode's reverse voltage (V_R) is expressed by Equation (2) according to the voltage drop across the external resistor. This is indicated as load lines in Figure 2.

$$V_R = V_{CC} - I_L \times R_L \dots\dots\dots (2)$$

In Figure 2, the intersections between the output curves and the load lines are the saturation points. From these points, the maximum detectable light level can be specified. Since the maximum light level is determined by the supply voltage (V_{CC}) and load resistance (R_L), adjust them according to the operating conditions.

Note: The temperature characteristics of $V_{be(ON)}$ is approximately $-2 \text{ mV}/^\circ\text{C}$, and that of the protection resistor is approximately $0.1\%/^\circ\text{C}$.

[Figure 1] Measurement circuit example

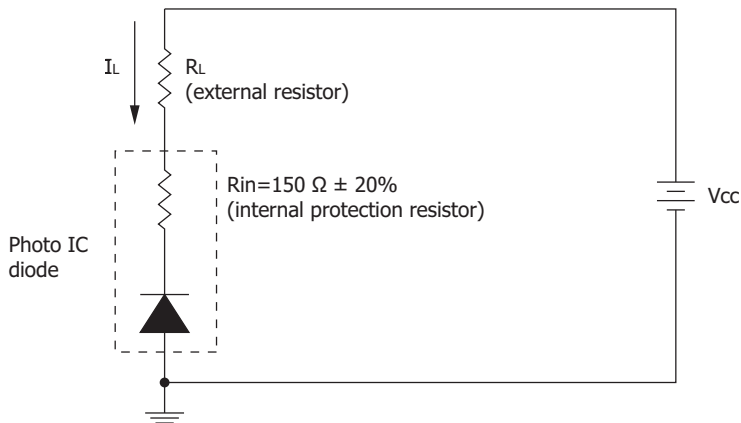

KPIC0128EC

[Figure 2] Photocurrent vs. reverse voltage

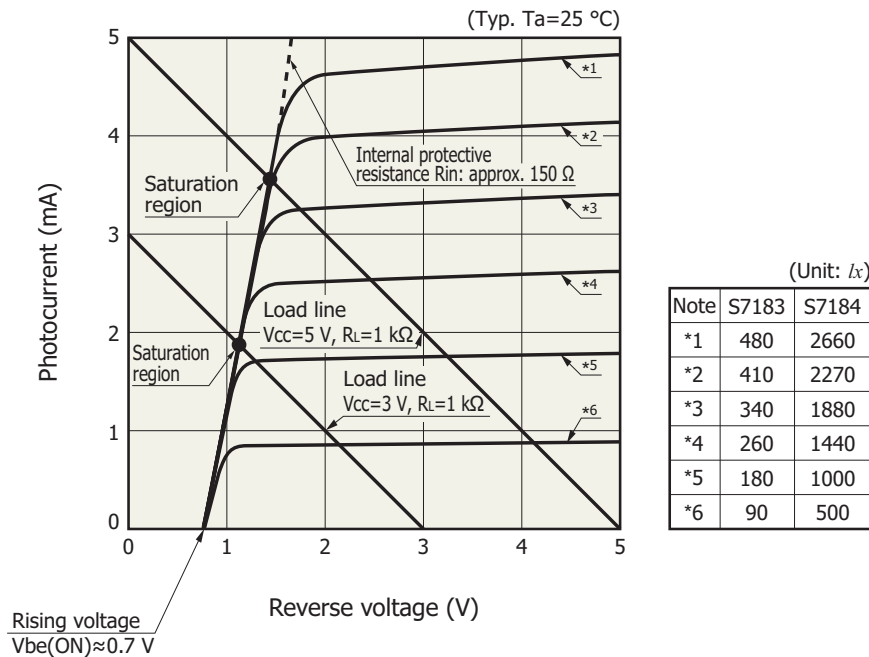

KPICB0195EC

Recommended soldering conditions

Type No.	Solder temperature	Remarks
S7183	260 °C (less than 3 s) max.	at least 2.5 mm away from lead roots
S7184	*4	-

*4: Contact us for detailed information.

Note: When setting the soldering conditions, check for any problems by testing out the soldering methods in advance.

Related information

www.hamamatsu.com/sp/ssd/doc_en.html

Precautions

- Disclaimer
- Metal, ceramic, plastic package products
- Surface mount type products

Information described in this material is current as of March 2021.

Product specifications are subject to change without prior notice due to improvements or other reasons. This document has been carefully prepared and the information contained is believed to be accurate. In rare cases, however, there may be inaccuracies such as text errors. Before using these products, always contact us for the delivery specification sheet to check the latest specifications.

The product warranty is valid for one year after delivery and is limited to product repair or replacement for defects discovered and reported to us within that one year period. However, even if within the warranty period we accept absolutely no liability for any loss caused by natural disasters or improper product use. Copying or reprinting the contents described in this material in whole or in part is prohibited without our prior permission.