

**SPECIFICATIONS**

- 1.Body : Brass,QQ-B-626  
Gold Plated 3 Micro-Inches Min Thick Over Nickel  
Plated 100Micro-Inches Min. Thick Over Copper Strike
- 2.Insulator:Teflon MIL-P-19468
- 3.Contact Pin : Brass,QQ-B-626  
Gold Plated 3 Micro-Inches Min Thick Over Nickel  
Plated 100Micro-Inches Min. Thick Over Copper Strike
- 4.Washer : Brass,QQ-B-626  
Gold Plated 3 Micro-Inches Min Thick Over Nickel  
Plated 100Micro-Inches Min. Thick Over Copper Strike
- 5.Nut : Brass,QQ-B-626  
Gold Plated 3 Micro-Inches Min Thick Over Nickel  
Plated 100Micro-Inches Min. Thick Over Copper Strike

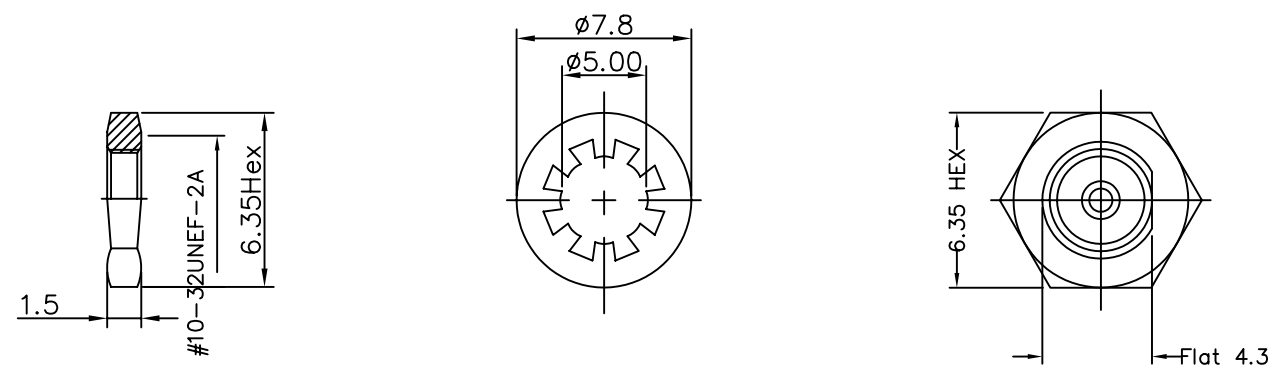

**AUK** A MEMBER OF AUK GROUP  
**太聯事業股份有限公司**  
**AUK CONTRACTORS CO., LTD.**

CATEGORY		APPROVED BY MEI		UNLESS OTHERWISE SPECIFIED TOLERANCES ARE .X .XX ±0.20 AWG.					
PART No. SMB-JSB50		CHECKED BY BECKY							
DRAWING No. SMB-JSB50		DRAWING BY HZF							
SCALE	NONE	REV.	A		UNIT mm		AREA	REVISIONS	CHK