

Push-Pull Four Channel Driver

FEATURES

- Output Current 1A Per Channel (600mA for L293D)
- Peak Output Current 2A Per Channel (1.2A for L293D)
- Inhibit Facility
- High Noise Immunity
- Separate Logic Supply
- Over-Temperature Protection

DESCRIPTION

The L293 and L293D are quad push-pull drivers capable of delivering output currents to 1A or 600mA per channel respectively. Each channel is controlled by a TTL-compatible logic input and each pair of drivers (a full bridge) is equipped with an inhibit input which turns off all four transistors. A separate supply input is provided for the logic so that it may be run off a lower voltage to reduce dissipation.

Additionally the L293D includes the output clamping diodes within the IC for complete interfacing with inductive loads.

Both devices are available in 16-pin Batwing DIP packages. They are also available in Power SOIC and Hermetic DIL packages.

TRUTH TABLE

V _i (each channel)	V _{INH} *	V _o
H	H	H
L	H	L
H	L	X**
L	L	X**

*Relative to the considered channel
**High output impedance

ABSOLUTE MAXIMUM RATINGS

- Collector Supply Voltage, V_C 36V
 - Logic Supply Voltage, V_{SS} 36V
 - Input Voltage, V_i 7V
 - Inhibit Voltage, V_{INH} 7V
 - Peak Output Current (Non-Repetitive), I_{OUT} (L293) 2A
 - I_{OUT} (L293D) 1.2A
 - Total Power Dissipation
at T_{ground}-pins = 80°C, N Batwing pkg, (Note) 5W
 - Storage and Junction Temperature, T_{stg}, T_J -40 to +150°C
- Note: Consult packaging section of Databook for thermal limitations and considerations of packages.*

BLOCK DIAGRAM

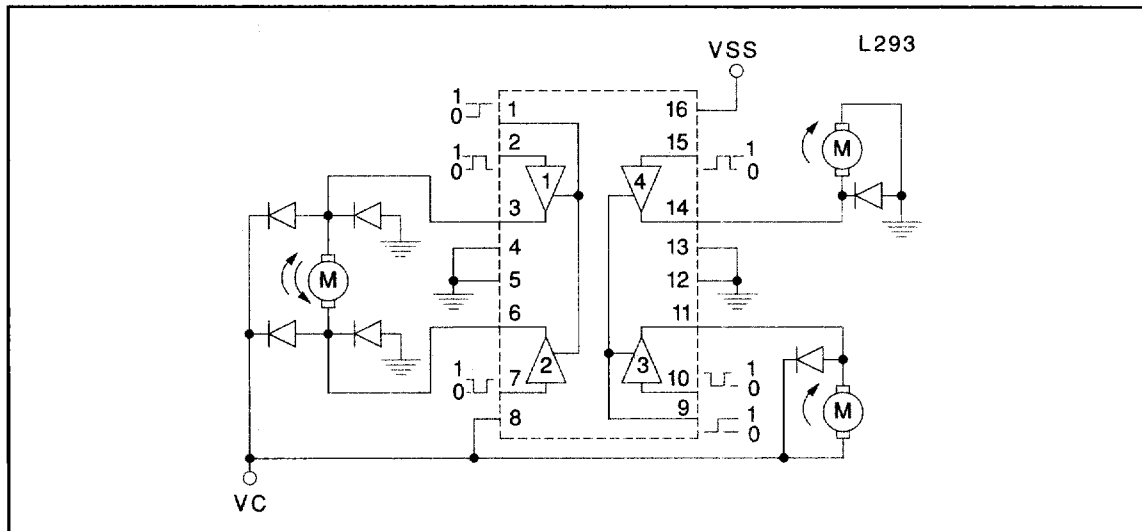

Note: Output diodes are internal in L293D.



CONNECTION DIAGRAMS

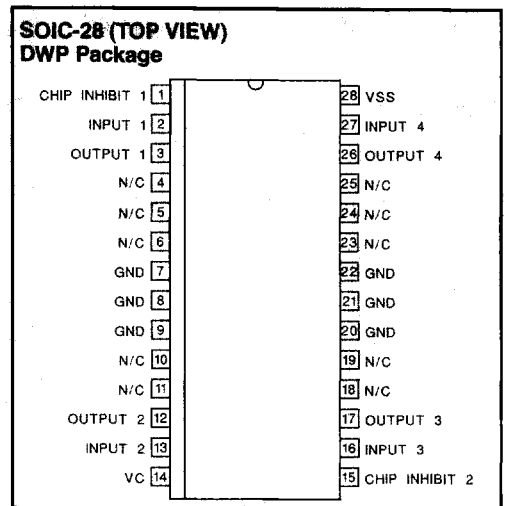
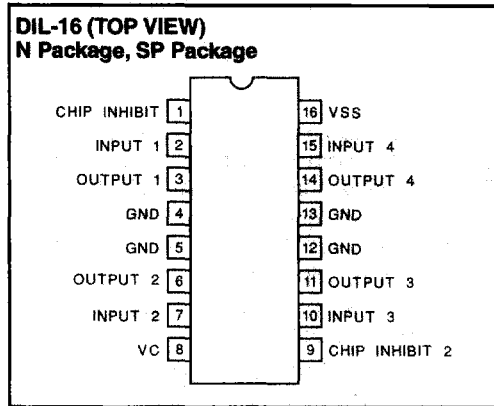

ELECTRICAL CHARACTERISTICS: (For each channel, $V_C = 24V$, $V_{SS} = 5V$, $T_{AMB} = 25^\circ C$, unless otherwise specified; $T_A = T_J$)

PARAMETER	SYMBOL	TEST CONDITION	MIN.	TYP.	MAX.	UNITS
Collector Supply Voltage	V_C				36	V
Logic Supply Voltage	V_{SS}		4.5		36	V
Collector Supply Current	I_C	$V_I = L, I_O = 0, V_{INH} = H$		2	6	mA
		$V_I = H, I_O = 0, V_{INH} = H$		16	24	mA
		$V_{INH} = L$			4	mA
Total Quiescent Logic Supply Current	I_{SS}	$V_I = L, I_O = 0, V_{INH} = H$		44	60	mA
		$V_I = H, I_O = 0, V_{INH} = H$		16	22	mA
		$V_{INH} = L$		16	24	mA
Input Low Voltage	V_{IL}		-0.3		1.5	V
Input High Voltage	V_{IH}	$V_{SS} \leq 7V$	2.3		V_{SS}	V
		$V_{SS} \geq 7V$	2.3		7	V
Low Voltage Input Current	I_{IL}	$V_I = 0V$			-10	μA
High Voltage Input Current	I_{IH}	$V_I = 4.5V$		30	100	μA
Inhibit Low Voltage	$V_{INH, L}$		-0.3		1.5	V
Inhibit High Voltage	$V_{INH, H}$	$V_{SS} \leq 7V$	2.3		V_{SS}	V
		$V_{SS} > 7V$	2.3		7	V
Low Voltage Inhibit Current	$V_{INH, L}$			-30	-100	μA
High Voltage Inhibit Current	$V_{INH, H}$				10	μA
Source Output Saturation Voltage	V_{CEsatH}	$I_O = -1A$ (-0.6A for L293D)		1.4	1.8	V
Sink Output Saturation Voltage	V_{CEsatL}	$I_O = 1A$ (0.6A for L293D)		1.2	1.8	V
Clamp Diode Forward Voltage (L293D only)	V_F	$I_F = 0.6A$		1.3		V
Rise Time	T_R	0.1 to 0.9 V_O (See Figure 1)		100		ns
Fall Time	T_F	0.9 to 0.1 V_O (See Figure 1)		350		ns
Turn-on Delay	T_{ON}	0.5 V_I to 0.5 V_O (See Figure 1)		750		ns
Turn-off Delay	T_{OFF}	0.5 V_I to 0.5 V_O (See Figure 1)		200		ns

SCHEMATIC DIAGRAM

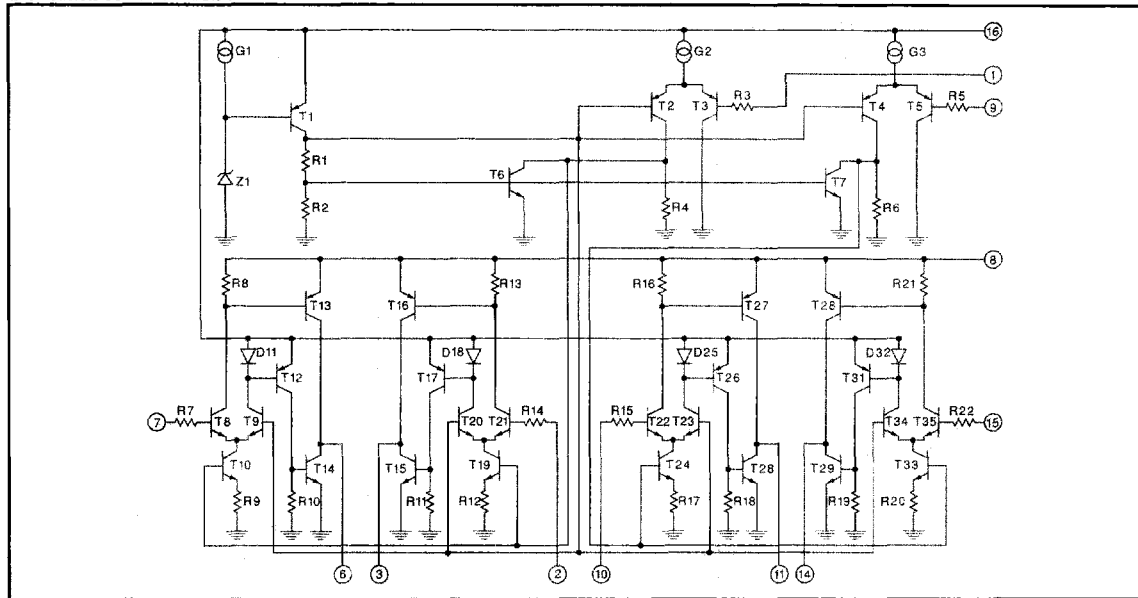

APPLICATION INFORMATION

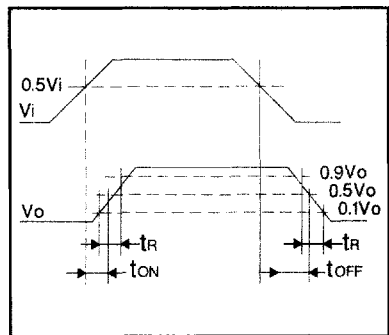

Figure 1: Switching Times

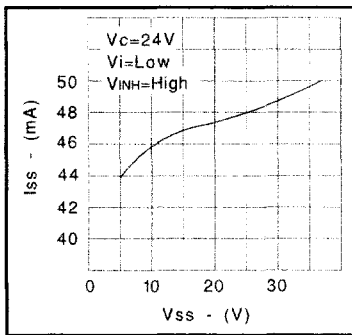

Figure 2: Quiescent Logic Supply Current vs Logic Supply Voltage

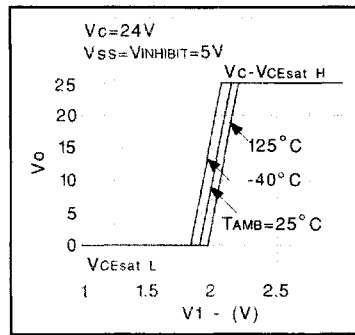

Figure 3: Output Voltage vs Input Voltage

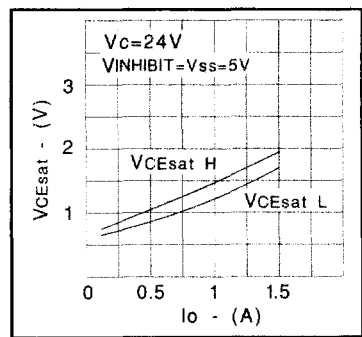

Figure 4: L293 Saturation vs Output Current

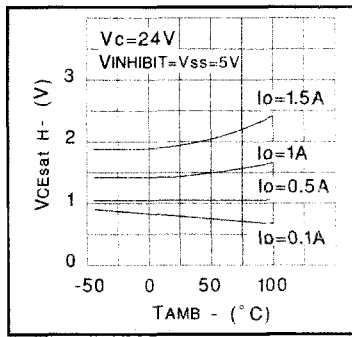

Figure 5: L293 Source Saturation vs Ambient Temperature

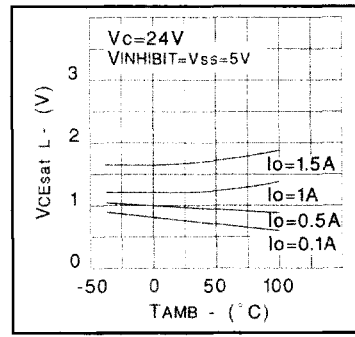

Figure 6: L293 Sink Saturation Voltage vs Ambient Temperature

NOTE: For L293D curves, multiply output current by 0.6.

APPLICATION INFORMATION (Cont.)

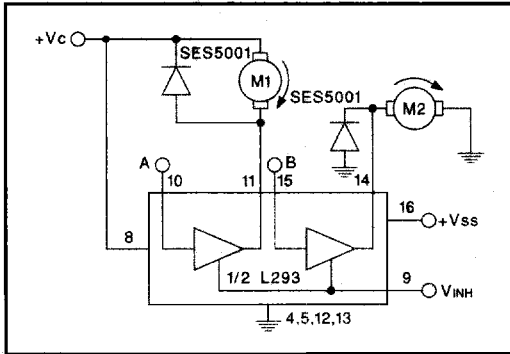

Figure 7: DC Motor Controls (with Connection to Ground and to Supply Voltage)

V _{INH}	A	M1	B	M2
H	H	Fast Motor Stop	H	Run
H	L	Run	L	Fast Motor Stop
L	X	Free Running Motor Stop	X	Free Running Motor Stop

L = Low H = High X = Don't Care

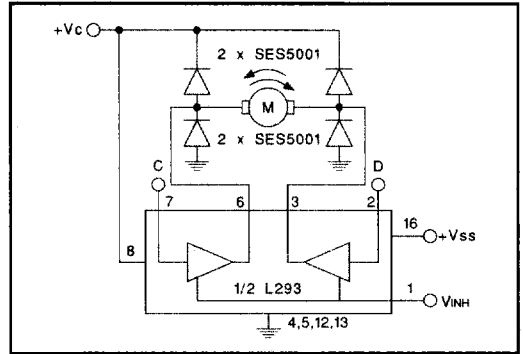

Figure 8: Bidirectional DC Motor Control

INPUTS		FUNCTION
V _{INH} = H	C = H; D = L	Turn Right
	C = L; D = H	Turn Left
	C = D	Fast Motor Stop
V _{INH} = L	C = X; D = X	Free Running Motor Stop

L = Low H = High X = Don't Care

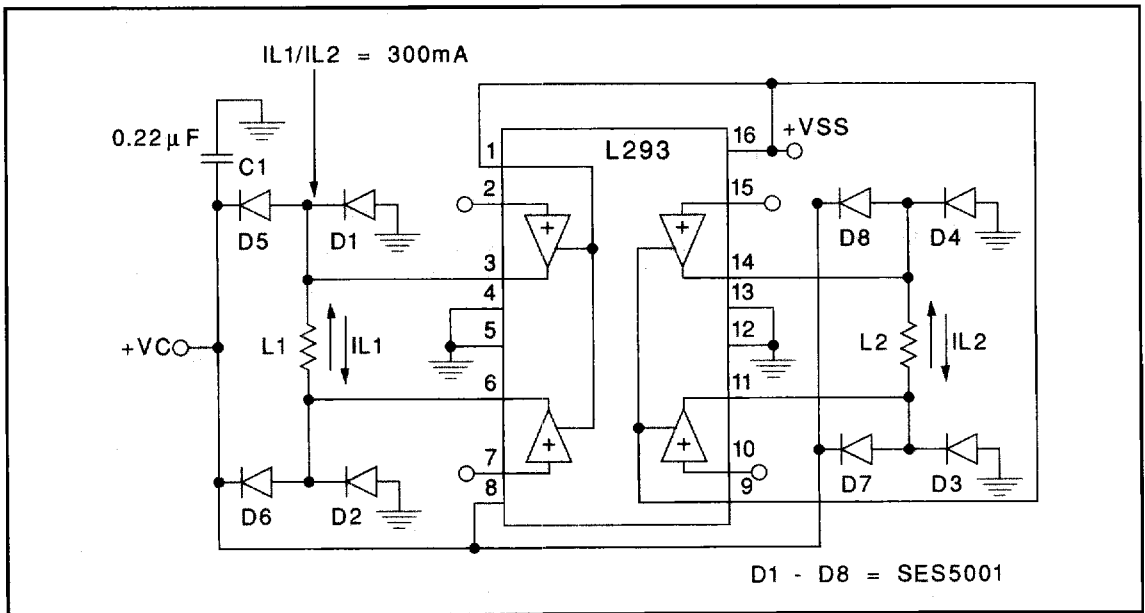

Figure 9: Bipolar Stepping Motor Control

MOUNTING INSTRUCTIONS

The Rthj-amp of the L293 can be reduced by soldering the GND pins to a suitable copper area of the printed circuit board or to an external heatsink.

The diagram of Figure 13 shows the maximum package power P_{TOT} and the θ_{JA} as a function of the side "l" of two equal square copper areas having a thickness of 35μ (see

Figure 10). In addition, it is possible to use an external heatsink (see Figure 11).

During soldering the pins' temperature must not exceed 260°C and the soldering time must not be longer than 12 seconds.

The external heatsink or printed circuit copper area must be connected to electrical ground.

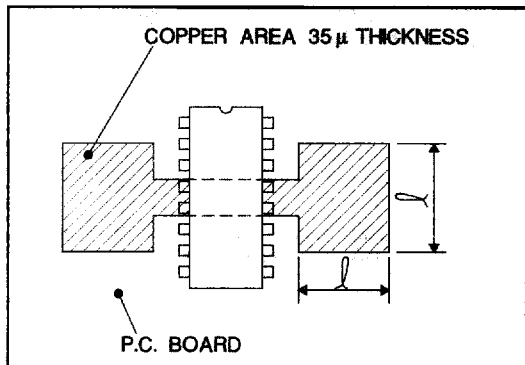

Figure 10: Example of P.C. Board Copper Area which is used as Heatsink

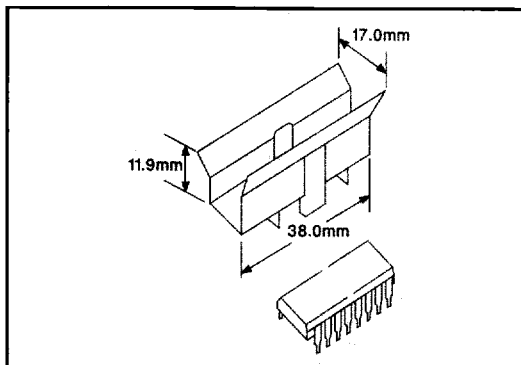

Figure 11: External Heatsink Mounting Example ($\theta_{JA} = 25^{\circ}\text{C/W}$)

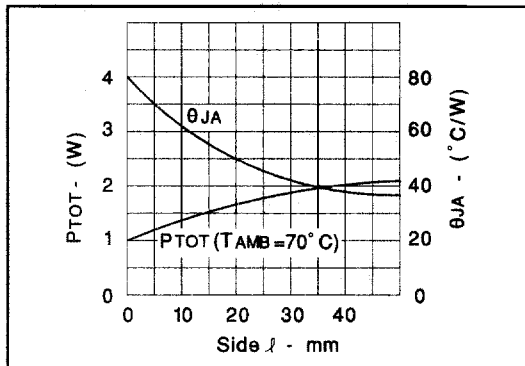

Figure 12: Maximum Package Power and Junction to Ambient Thermal Resistance

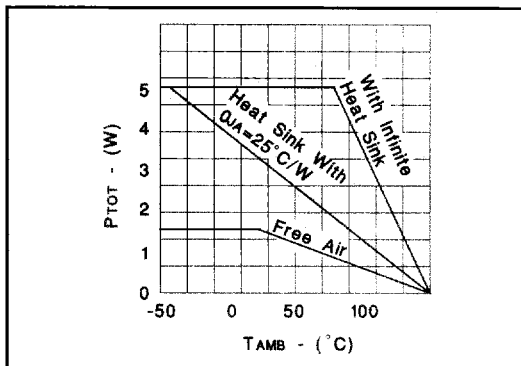

Figure 13: Maximum Allowable Power Dissipation vs Ambient Temperature

