

800 MHz Low Voltage PECL Clock Synthesizer

The MPC9230 is a 3.3V compatible, PLL based clock synthesizer targeted for high performance clock generation in mid-range to high-performance telecom, networking and computing applications. With output frequencies from 50 MHz to 800 MHz and the support of differential PECL output signals the device meets the needs of the most demanding clock applications.

Features

- 50 MHz to 800 MHz synthesized clock output signal
- Differential PECL output
- LVCMOS compatible control inputs
- On-chip crystal oscillator for reference frequency generation
- Alternative LVCMOS compatible reference clock input
- 3.3V power supply
- Fully integrated PLL
- Minimal frequency overshoot
- Serial 3-wire programming interface
- Parallel programming interface for power-up
- 32 lead LQFP and 28 PLCC packaging
- SiGe Technology
- Ambient temperature range 0°C to +70°C
- Pin and function compatible to the MC12430

Functional Description

The internal crystal oscillator uses the external quartz crystal as the basis of its frequency reference. The frequency of the internal crystal oscillator is divided by 16 and then multiplied by the PLL. The VCO within the PLL operates over a range of 800 to 1600 MHz. Its output is scaled by a divider that is configured by either the serial or parallel interfaces. The crystal oscillator frequency f_{XTAL} , the PLL feedback-divider M and the PLL post-divider N determine the output frequency.

The feedback path of the PLL is internal. The PLL adjusts the VCO output frequency to be 8·M times the reference frequency by adjusting the VCO control voltage. Note that for some values of M (either too high or too low) the PLL will not achieve phase lock. The PLL will be stable if the VCO frequency is within the specified VCO frequency range (800 to 1600 MHz). The M-value must be programmed by the serial or parallel interface.

The PLL post-divider N is configured through either the serial or the parallel interfaces, and can provide one of four division ratios (1, 2, 4, or 8). This divider extends performance of the part while providing a 50% duty cycle. The output driver is driven differentially from the output divider, and is capable of driving a pair of transmission lines terminated 50Ω to $V_{CC} - 2.0V$. The positive supply voltage for the internal PLL is separated from the power supply for the core logic and output drivers to minimize noise induced jitter.

The configuration logic has two sections: serial and parallel. The parallel interface uses the values at the M[8:0] and N[1:0] inputs to configure the internal counters. It is recommended on system reset to hold the $\overline{P_LOAD}$ input LOW until power becomes valid. On the LOW-to-HIGH transition of $\overline{P_LOAD}$, the parallel inputs are captured. The parallel interface has priority over the serial interface. Internal pullup resistors are provided on the M[8:0] and N[1:0] inputs prevent the LVCMOS compatible control inputs from floating.

The serial interface centers on a fourteen bit shift register. The shift register shifts once per rising edge of the S_CLOCK input. The serial input S_DATA must meet setup and hold timing as specified in the AC Characteristics section of this document. The configuration latches will capture the value of the shift register on the HIGH-to-LOW edge of the S_LOAD input. See the programming section for more information. The TEST output reflects various internal node values, and is controlled by the T[2:0] bits in the serial data stream. In order to minimize the PLL jitter, it is recommended to avoid active signal on the TEST output.

MPC9230

**800 MHZ LOW VOLTAGE
CLOCK SYNTHESIZER**

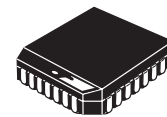

FN SUFFIX
28 LEAD PLCC PACKAGE
CASE 776



FA SUFFIX
32 LEAD LQFP PACKAGE
CASE 873A

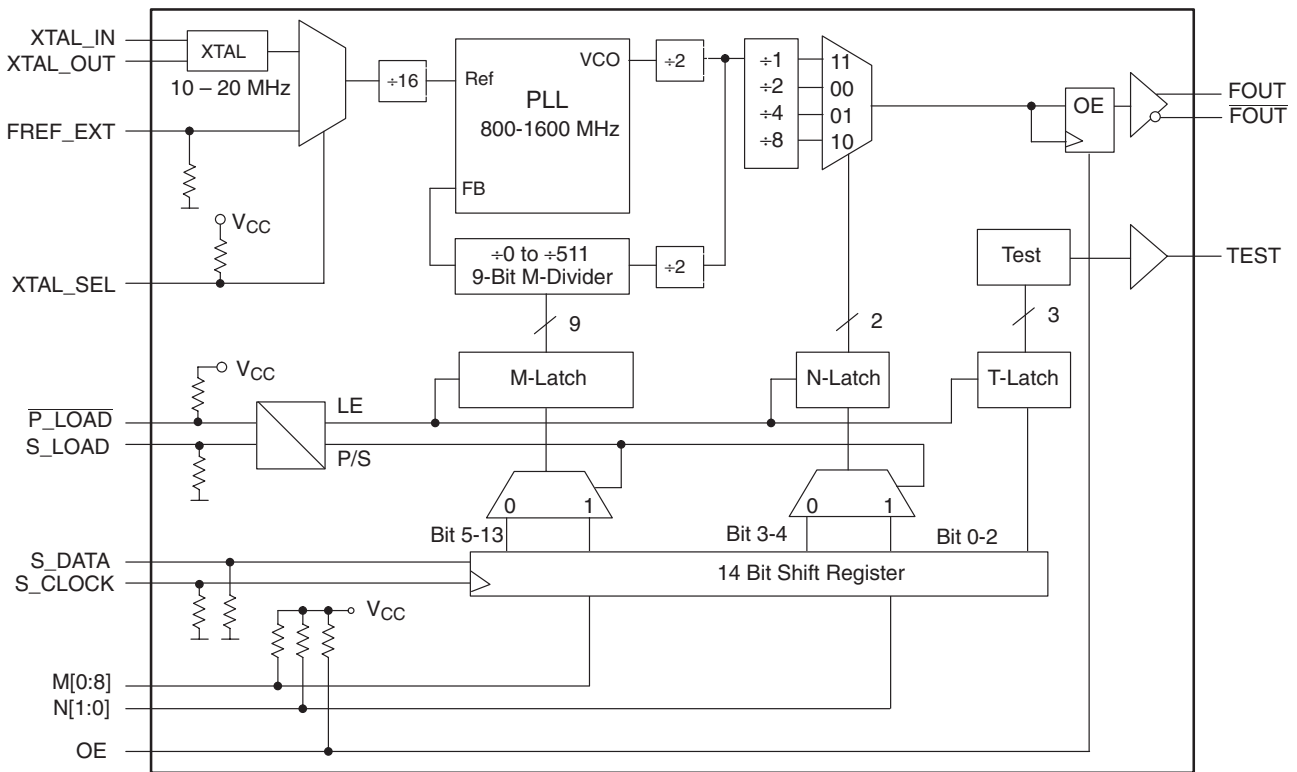

Figure 1. MPC9230 Logic Diagram

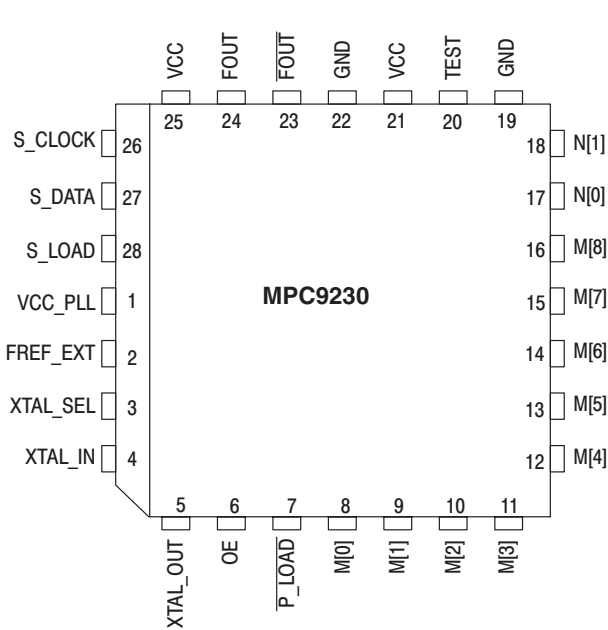

Figure 2. MPC9230 28-Lead PLCC Pinout (Top View)

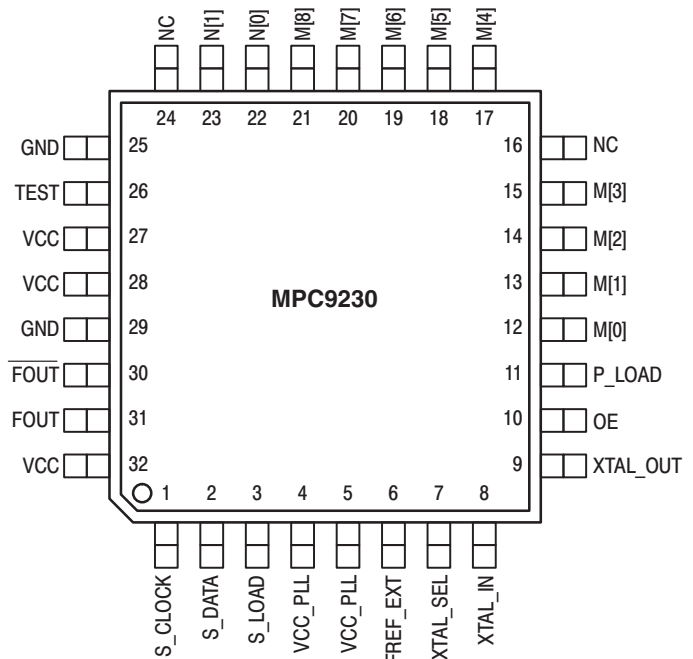

Figure 3. MPC9230 32-Lead Package Pinout (Top View)

Table 1. Pin Configuration

Pin	I/O	Default	Type	Function
XTAL_IN, XTAL_OUT			Analog	Crystal oscillator interface
FREF_EXT	Input	0	LVC MOS	Alternative PLL reference input
FOUT, $\overline{\text{FOUT}}$	Output		LVPECL	Differential clock output
TEST	Output		LVPECL	Test and device diagnosis output
XTAL_SEL	Input	1	LVC MOS	PLL reference select input
S_LOAD	Input	0	LVC MOS	Serial configuration control input. This input controls the loading of the configuration latches with the contents of the shift register. The latches will be transparent when this signal is high, thus the data must be stable on the high-to-low transition.
P_LOAD	Input	1	LVC MOS	Parallel configuration control input. This input controls the loading of the configuration latches with the content of the parallel inputs (M and N). The latches will be transparent when this signal is low, thus the parallel data must be stable on the low-to-high transition of P_LOAD. P_LOAD is state sensitive
S_DATA	Input	0	LVC MOS	Serial configuration data input.
S_CLOCK	Input	0	LVC MOS	Serial configuration clock input.
M[0:8]	Input	1	LVC MOS	Parallel configuration for PLL feedback divider (M). M is sampled on the low-to-high transition of $\overline{\text{P_LOAD}}$.
N[1:0]	Input	1	LVC MOS	Parallel configuration for Post-PLL divider (N). N is sampled on the low-to-high transition of $\overline{\text{P_LOAD}}$
OE	Input	1	LVC MOS	Output enable (active high) The output enable is synchronous to the output clock to eliminate the possibility of runt pulses on the FOUT output.
GND	Supply	Supply	Ground	Negative power supply (GND)
V _{CC}	Supply	Supply	V _{CC}	Positive power supply for I/O and core. All V _{CC} pins must be connected to the positive power supply for correct operation
VCC_PLL	Supply	Supply	V _{CC}	PLL positive power supply (analog power supply)

Table 2. Output frequency range and PLL Post-divider N

N		Output division	Output frequency range
1	0		
0	0	2	200 - 400 MHz
0	1	4	100 - 200 MHz
1	0	8	50 - 100 MHz
1	1	1	400 - 800 MHz

Table 3. Function Table

Input	0	1
XTAL_SEL	FREF_EXT	XTAL interface
OE	Outputs disabled, FOUT is stopped in the logic low state (FOUT = L, $\overline{\text{FOUT}}$ = H)	Outputs enabled

Table 4. General Specifications

Symbol	Characteristics	Min	Typ	Max	Unit	Condition
V_{TT}	Output termination voltage		$V_{CC} - 2$		V	
MM	ESD protection (Machine model)	200			V	
HBM	ESD protection (Human body model)	2000			V	
LU	Latch-up immunity	200			mA	
C_{IN}	Input capacitance		4.0		pF	Inputs
θ_{JA}	LQFP 32 Thermal resistance junction to ambient JESD 51-3, single layer test board		83.1	86.0	°C/W	Natural convection
			73.3	75.4	°C/W	100 ft/min
			68.9	70.9	°C/W	200 ft/min
			63.8	65.3	°C/W	400 ft/min
			57.4	59.6	°C/W	800 ft/min
	JESD 51-6, 2S2P multilayer test board		59.0	60.6	°C/W	Natural convection
			54.4	55.7	°C/W	100 ft/min
			52.5	53.8	°C/W	200 ft/min
			50.4	51.5	°C/W	400 ft/min
			47.8	48.8	°C/W	800 ft/min
θ_{JC}	LQFP 32 Thermal resistance junction to case		23.0	26.3	°C/W	MIL-SPEC 883E Method 1012.1

4

Table 5. Absolute Maximum Ratings^a

Symbol	Characteristics	Min	Max	Unit	Condition
V_{CC}	Supply Voltage	-0.3	4.6	V	
V_{IN}	DC Input Voltage	-0.3	$V_{CC} + 0.3$	V	
V_{OUT}	DC Output Voltage	-0.3	$V_{CC} + 0.3$	V	
I_{IN}	DC Input Current		±20	mA	
I_{OUT}	DC Output Current		±50	mA	
T_S	Storage Temperature	-65	125	°C	

a. Absolute maximum continuous ratings are those maximum values beyond which damage to the device may occur. Exposure to these conditions or conditions beyond those indicated may adversely affect device reliability. Functional operation at absolute-maximum-rated conditions is not implied.

Table 6. DC Characteristics ($V_{CC} = 3.3V \pm 5\%$, $T_A = 0^\circ\text{C}$ to $+70^\circ\text{C}$)

Symbol	Characteristics	Min	Typ	Max	Unit	Condition
LVCMOS control inputs (FREF_EXT, XTAL_SEL, P_LOAD, S_LOAD, S_DATA, S_CLOCK, M[0:8], N[0:1], OE)						
V_{IH}	Input High Voltage	2.0		$V_{CC} + 0.3$	V	LVCMOS
V_{IL}	Input Low Voltage			0.8	V	LVCMOS
I_{IN}	Input Current ^a			±200	μA	$V_{IN} = V_{CC}$ or GND
Differential clock output F_{OUT}^b						
V_{OH}	Output High Voltage	$V_{CC} - 1.02$		$V_{CC} - 0.74$	V	LVPECL
V_{OL}	Output Low Voltage	$V_{CC} - 1.95$		$V_{CC} - 1.60$	V	LVPECL
Test and diagnosis output TEST						
V_{OH}	Output High Voltage	$V_{CC} - 1.02$		$V_{CC} - 0.74$	V	LVPECL
V_{OL}	Output Low Voltage	$V_{CC} - 1.95$		$V_{CC} - 1.60$	V	LVPECL
Supply current						
I_{CC_PLL}	Maximum PLL Supply Current			20	mA	V_{CC_PLL} Pins
I_{CC}	Maximum Supply Current			110	mA	All V_{CC} Pins

a. Inputs have pull-down resistors affecting the input current.

b. Outputs terminated 50Ω to $V_{TT} = V_{CC} - 2V$.

Table 7. AC Characteristics ($V_{CC} = 3.3V \pm 5\%$, $T_A = 0^\circ C$ to $+70^\circ C$)^a

Symbol	Characteristics	Min	Typ	Max	Unit	Condition
f_{XTAL}	Crystal interface frequency range	10		20	MHz	
f_{REF}	FREF_EXT reference frequency range	10		$(f_{VCO,MAX} \div M) \cdot 4$ ^b	MHz	
f_{VCO}	VCO frequency range ^c	800		1600	MHz	
f_{MAX}	Output Frequency	N = 11 (+1)	400	800	MHz	
		N = 00 (+2)	200	400	MHz	
		N = 01 (+4)	100	200	MHz	
		N = 10 (+8)	50	100	MHz	
f_{S_CLOCK}	Serial interface programming clock frequency ^d	0		10	MHz	
$t_{P,MIN}$	Minimum pulse width (S_LOAD, P_LOAD)	50			ns	
DC	Output duty cycle	45	50	55	%	
t_r, t_f	Output Rise/Fall Time	0.05		0.3	ns	20% to 80%
t_s	Setup Time	S_DATA to S_CLOCK	20		ns	
		S_CLOCK to S_LOAD	20		ns	
		M, N to P_LOAD	20		ns	
t_s	Hold Time	S_DATA to S_CLOCK	20		ns	
		M, N to P_LOAD	20		ns	
$t_{JIT(CC)}$	Cycle-to-cycle jitter	N = 11 (+1)		80	ps	
		N = 00 (+2)		90	ps	
		N = 01 (+4)		130	ps	
		N = 10 (+8)		160	ps	
$t_{JIT(PER)}$	Period Jitter	N = 11 (+1)		60	ps	
		N = 00 (+2)		70	ps	
		N = 01 (+4)		120	ps	
		N = 10 (+8)		140	ps	
t_{LOCK}	Maximum PLL Lock Time			10	ms	

a AC characteristics apply for parallel output termination of 50Ω to V_{TT} .

b The maximum frequency on FREF_EXT is a function of the max. VCO frequency and the M counter. M should be higher than 160 for stable PLL operation.

c The input frequency f_{XTAL} and the PLL feedback divider M must match the VCO frequency range: $f_{VCO} = f_{XTAL} \cdot M \div 4$.

d The frequency of S_CLOCK is limited to 10 MHz in serial programming mode. S_CLOCK can be switched at higher frequencies when used as test clock in test mode 6. See application section for more details.

Programming the MPC9230

Programming the MPC9230 amounts to properly configuring the internal PLL dividers to produce the desired synthesized frequency at the output. The output frequency can be represented by this formula:

$$f_{OUT} = (f_{XTAL} \div 16) \cdot (4 \cdot M) \div (2 \cdot N) \text{ or} \quad (1)$$

$$f_{OUT} = (f_{XTAL} \div 8) \cdot M \div N \quad (2)$$

where f_{XTAL} is the crystal frequency, M is the PLL feedback-divider and N is the PLL post-divider. The input frequency and the selection of the feedback divider M is limited by the VCO-frequency range. f_{XTAL} and M must be configured to

match the VCO frequency range of 800 to 1600 MHz in order to achieve stable PLL operation:

$$M_{MIN} = 4 \cdot f_{VCO,MIN} \div f_{XTAL} \text{ and} \quad (3)$$

$$M_{MAX} = 4 \cdot f_{VCO,MAX} \div f_{XTAL} \quad (4)$$

For instance, the use of a 16 MHz input frequency requires the configuration of the PLL feedback divider between M=200 and M = 400. Table 8 shows the usable VCO frequency and M divider range for other example input frequencies. Assuming that a 16 MHz input frequency is used, equation (2) reduces to:

$$f_{OUT} = 2 \cdot M \div N \quad (5)$$

Table 8. MPC9230 Frequency Operating Range

M	M[8:0]	VCO frequency for an crystal interface frequency of						Output frequency for $f_{XTAL}=16$ MHz and for N =			
		10	12	14	16	18	20	1	2	4	8
160	010100000						800				
170	010101010						850				
180	010110100					810	900				
190	010111110					855	950				
200	011001000				800	900	1000	400	200	100	50
210	011010010				840	945	1050	420	210	105	52.5
220	011011100				880	990	1100	440	220	110	55
230	011100110			805	920	1035	1150	460	230	115	57.5
240	011110000			840	960	1080	1200	480	240	120	60
250	011111010			875	100	1125	1250	500	250	125	62.5
260	100000100			910	1040	1170	1300	520	260	130	65
270	100001110		810	945	1080	1215	1350	540	270	135	67.5
280	100011000		840	980	1120	1260	1400	560	280	140	70
290	100100010		870	1015	1160	1305	1450	580	290	145	72.5
300	100101100		900	1050	1200	1350	1500	600	300	150	75
310	100110110		930	1085	1240	1395	1550	620	310	155	77.5
320	101000000	800	960	1120	1280	1440	1600	640	320	160	80
330	101001010	825	990	1155	1320	1485		660	330	165	82.5
340	101010100	850	1020	1190	1360	1530		680	340	170	85
350	101011110	875	1050	1225	1400	1575		700	350	175	87.5
370	101110010	925	1110	1295	1480			740	370	185	92.5
380	101111100	950	1140	1330	1520			760	380	190	95
390	110000110	975	1170	1365	1560			780	390	195	97.5
400	110010000	1000	1200	1400	1600			800	400	200	100
410	110011010	1025	1230	1435							
420	110100100	1050	1260	1470							
430	110101110	1075	1290	1505							
440	110111000	1100	1320	1540							
450	111000010	1125	1350	1575							
510	111111110	1275	1530								

Substituting N for the four available values for N (1, 2, 4, 8) yields:

Table 9. Output Frequency Range for $f_{XTAL} = 16$ MHz

N			F _{OUT}	F _{OUT} range	F _{OUT} step
1	0	Value			
0	0	2	M	200 - 400 MHz	1 MHz
0	1	4	M+2	100 - 200 MHz	500 kHz
1	0	8	M+4	50 - 100 MHz	250 kHz
1	1	1	2 · M	400 - 800 MHz	2 MHz

Example frequency calculation for an 16 MHz input frequency

If an output frequency of 131 MHz was desired the following steps would be taken to identify the appropriate M and N values. According to Table 9, 131 MHz falls in the frequency set by a value of 4 so N[1:0] = 01. For N = 4 the output frequency is F_{OUT} = M + 2 and M = F_{OUT} × 2. Therefore M = 2 × 131 = 262, so M[8:0] = 01000011. Following this procedure a user can generate any whole frequency between 50 MHz and 800 MHz. Note that for N > 2 fractional values of can be realized. The size of the programmable frequency steps (and thus the indicator of the fractional output frequencies achievable) will be equal to:

$$f_{STEP} = f_{XTAL} \div 8 \div N \quad (6)$$

Using the parallel and serial interface

The M and N counters can be loaded either through a parallel or serial interface. The parallel interface is controlled via the P_LOAD signal such that a LOW to HIGH transition will latch the information present on the M[8:0] and N[1:0] inputs into the M and N counters. When the P_LOAD signal is LOW the input latches will be transparent and any changes on the M[8:0] and N[1:0] inputs will affect the FOUT output pair. To use the serial port the S_CLOCK signal samples the information on the S_DATA line and loads it into a 14 bit shift register. Note that the P_LOAD signal must be HIGH for the serial load operation to function. The Test register is loaded with the first three bits, the N register with the next two and the M register with the final eight bits of the data stream on the S_DATA input. For each register the most significant bit is loaded first (T2, N1 and M8). A pulse on the S_LOAD pin after the shift register is fully loaded will transfer the divide values into the counters. The HIGH to LOW transition on the S_LOAD input will latch the new divide values into the counters. Figure 4 illustrates the timing diagram for both a parallel and a serial load of the MPC9230 synthesizer. M[8:0] and N[1:0] are normally specified once at power-up through the parallel interface, and then possibly again through the serial interface. This approach allows the application to come up at one frequency and then change or fine-tune the clock as the ability to control the serial interface becomes available.

Using the test and diagnosis output TEST

The TEST output provides visibility for one of the several internal nodes as determined by the T[2:0] bits in the serial configuration stream. It is not configurable through the parallel interface. Although it is possible to select the node that represents F_{OUT}, the LVPECL compatible TEST output is not able to toggle fast enough for higher output frequencies and should only be used for test and diagnosis. The T2, T1 and T0 control bits are preset to '000' when P_LOAD is LOW so that the LVPECL compatible FOUT outputs are as jitter-free as possible. Any active signal on the TEST output pin will have detrimental affects on the jitter of the PECL output pair. In normal operations, jitter specifications are only guaranteed if the TEST output is static. The serial configuration port can be used to select one of the alternate functions for this pin. Most of the signals available on the TEST output pin are useful only for performance verification of the MPC9230 itself. However the PLL bypass mode may be of interest at the board level for functional debug. When T[2:0] is set to 110 the MPC9230 is placed in PLL bypass mode. In this mode the S_CLOCK input is fed directly into the M and N dividers. The N divider drives the F_{OUT} differential pair and the M counter drives the TEST output pin. In this mode the S_CLOCK input could be used for low speed board level functional test or debug. Bypassing the PLL and driving F_{OUT} directly gives the user more control on the test clocks sent through the clock tree. Table 10 shows the functional setup of the PLL bypass mode. Because the S_CLOCK is a CMOS level the input frequency is limited to 200 MHz. This means the fastest the F_{OUT} pin can be toggled via the S_CLOCK is 50 MHz as the divide ratio of the Post-PLL divider is 4 (if N = 1). Note that the M counter output on the TEST output will not be a 50% duty cycle.

Table 10. Test and Debug Configuration for TEST

T[2:0]			TEST output
T2	T1	T0	
0	0	0	14-bit shift register out ^a
0	0	1	Logic 1
0	1	0	$f_{XTAL} \div 16$
0	1	1	M-Counter out
1	0	0	FOUT
1	0	1	Logic 0
1	1	0	M-Counter out in PLL-bypass mode
1	1	1	$F_{OUT} \div 4$

a. Clocked out at the rate of S_CLOCK

Table 11. Debug Configuration for PLL bypass^a

Output	Configuration
F _{OUT}	$S_CLOCK \div N$
TEST	M-Counter out ^b

a. T[2:0]=110. AC specifications do not apply in PLL bypass mode

b. clocked out at the rate of $S_CLOCK \div (2 \cdot N)$

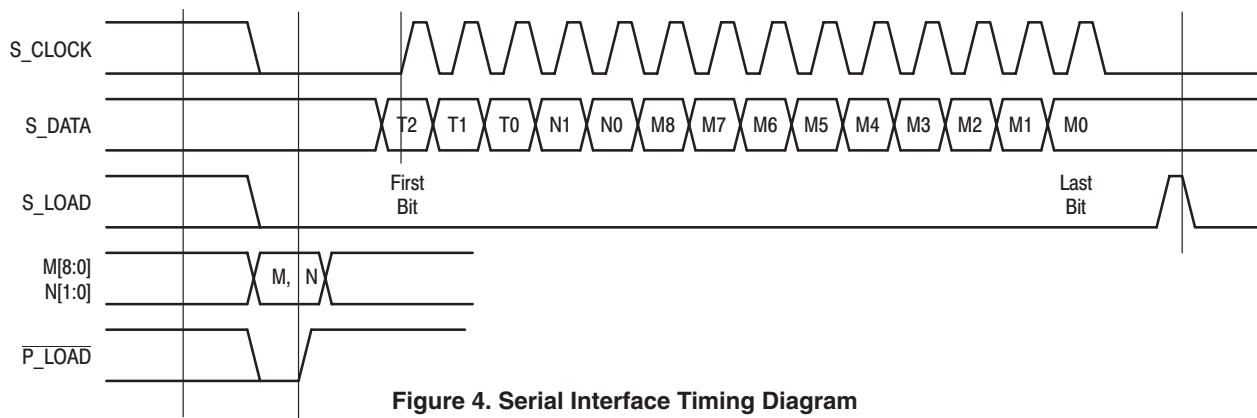

Figure 4. Serial Interface Timing Diagram

Power Supply Filtering

The MPC9230 is a mixed analog/digital product. Its analog circuitry is naturally susceptible to random noise, especially if this noise is seen on the power supply pins. Random noise on the VCC_PLL pin impacts the device characteristics. The MPC9230 provides separate power supplies for the digital circuitry (VCC) and the internal PLL (VCC_PLL) of the device. The purpose of this design technique is to try and isolate the high switching noise digital outputs from the relatively sensitive internal analog phase-locked loop. In a controlled environment such as an evaluation board, this level of isolation is sufficient. However, in a digital system environment where it is more difficult to minimize noise on the power supplies a second level of isolation may be required. The simplest form of isolation is a power supply filter on the VCC_PLL pin for the MPC9230. Figure 5 illustrates a typical power supply filter scheme. The MPC9230 is most susceptible to noise with spectral content in the 1 kHz to 1 MHz range. Therefore, the filter should be designed to target this range. The key parameter that needs to be met in the final filter design is the DC voltage drop that will be seen between the VCC supply and the MPC9230 pin of the MPC9230. From the data sheet, the VCC_PLL current (the current sourced through the VCC_PLL pin) is maximum 20 mA, assuming that a minimum of 2.835 V must be maintained on the VCC_PLL pin. The resistor shown in Figure 5 must have a resistance of 10-15 Ω to meet the voltage drop criteria. The RC filter pictured will provide a broadband filter with approximately 100:1 attenuation for noise whose spectral content is above 20 kHz. As the noise frequency crosses the series resonant point of an individual capacitor its overall impedance begins to look inductive and thus increases with increasing frequency. The parallel capacitor combination shown ensures that a low impedance path to ground exists for frequencies well above the bandwidth of the PLL. Generally, the resistor/capacitor filter will be cheaper, easier to implement and provide an adequate level of supply filtering. A higher level of attenuation can be achieved by replacing the resistor with an appropriate valued inductor. A 1000 μ H choke will show a significant impedance at 10 kHz frequencies and above. Because of the current draw and the voltage that must be maintained on the VCC_PLL pin, a low DC resistance inductor is required (less than 15 Ω).

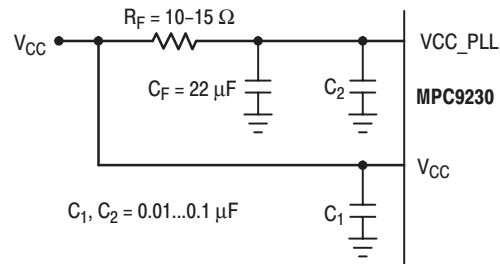

Figure 5. VCC_PLL Power Supply Filter

Layout Recommendations

The MPC9230 provides sub-nanosecond output edge rates and thus a good power supply bypassing scheme is a must. Figure 6 shows a representative board layout for the MPC9230. There exists many different potential board layouts and the one pictured is but one. The important aspect of the layout in Figure 6 is the low impedance connections between VCC and GND for the bypass capacitors. Combining good quality general purpose chip capacitors with good PCB layout techniques will produce effective capacitor resonances at frequencies adequate to supply the instantaneous switching current for the MPC9230 outputs. It is imperative that low inductance chip capacitors are used; it is equally important that the board layout does not introduce back all of the inductance saved by using the leadless capacitors. Thin interconnect traces between the capacitor and the power plane should be avoided and multiple large vias should be used to tie the capacitors to the buried power planes. Fat interconnect and large vias will help to minimize layout induced inductance and thus maximize the series resonant point of the bypass capacitors. Note the dotted lines circling the crystal oscillator connection to the device. The oscillator is a series resonant circuit and the voltage amplitude across the crystal is relatively small. It is imperative that no actively switching signals cross under the crystal as crosstalk energy coupled to these lines could significantly impact the jitter of the device. Special attention should be paid to the layout of the crystal to ensure a stable, jitter free interface between the crystal and the on-board oscillator. Although the MPC9230 has several design features to minimize the susceptibility to power supply noise (isolated power and grounds and fully differential

PLL), there still may be applications in which overall performance is being degraded due to system power supply noise. The power supply filter and bypass schemes discussed in this section should be adequate to eliminate power supply noise related problems in most designs.

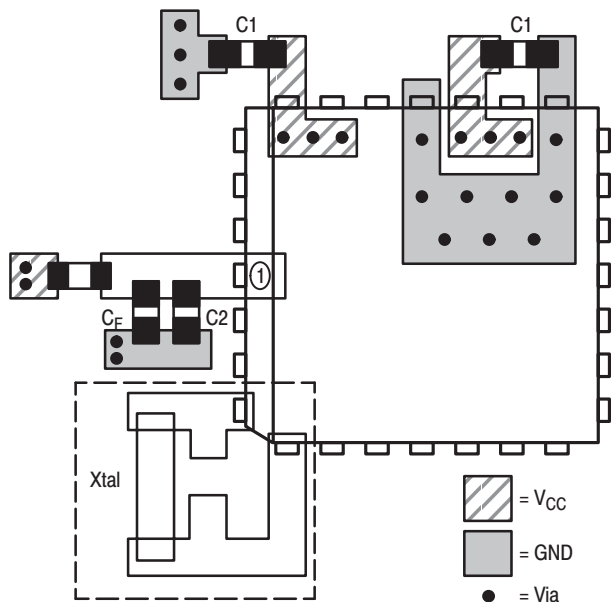

Figure 6. PCB Board Layout Recommendation for the PLCC28 Package

Using the On-Board Crystal Oscillator

The MPC9230 features a fully integrated on-board crystal oscillator to minimize system implementation costs. The oscillator is a series resonant, multivibrator type design as opposed to the more common parallel resonant oscillator design. The series resonant design provides better stability and eliminates the need for large on chip capacitors. The oscillator is totally self contained so that the only external component required is the crystal. As the oscillator is somewhat sensitive to loading on its inputs the user is advised to mount the crystal as close to the MPC9230 as possible to avoid any board level

parasitics. To facilitate co-location surface mount crystals are recommended, but not required. Because the series resonant design is affected by capacitive loading on the xtal terminals loading variation introduced by crystals from different vendors could be a potential issue. For crystals with a higher shunt capacitance it may be required to place a resistance across the terminals to suppress the third harmonic. Although typically not required it is a good idea to layout the PCB with the provision of adding this external resistor. The resistor value will typically be between 500 and 1KΩ.

The oscillator circuit is a series resonant circuit and thus for optimum performance a series resonant crystal should be used. Unfortunately most crystals are characterized in a parallel resonant mode. Fortunately there is no physical difference between a series resonant and a parallel resonant crystal. The difference is purely in the way the devices are characterized. As a result a parallel resonant crystal can be used with the MPC9230 with only a minor error in the desired frequency. A parallel resonant mode crystal used in a series resonant circuit will exhibit a frequency of oscillation a few hundred ppm lower than specified, a few hundred ppm translates to kHz inaccuracies. In a general computer application this level of inaccuracy is immaterial. Table 12 below specifies the performance requirements of the crystals to be used with the MPC9230.

Table 12. Recommended Crystal Specifications

Parameter	Value
Crystal Cut	Fundamental AT Cut
Resonance	Series Resonance*
Frequency Tolerance	±75ppm at 25°C
Frequency/Temperature Stability	±150ppm 0 to 70°C
Operating Range	0 to 70°C
Shunt Capacitance	5–7pF
Equivalent Series Resistance (ESR)	50 to 80Ω
Correlation Drive Level	100μW
Aging	5ppm/Yr (First 3 Years)

* See accompanying text for series versus parallel resonant discussion.