

## Ge-Avalanche Photodiode with Pigtail

SRD 00514X  
SRD 00515X

- Designed for application in fiber-optic communication systems
- Sensitive receiver for the 2<sup>nd</sup> optical window (1300 nm)
- High gain-bandwidth product
- Suitable for bit rates up to 1.2 Gbit/s and long-haul transmission
- Planar structure
- Small radiant sensitive area
- Low multiplied dark current
- High spectral sensitivity by built-in optics
- Hermetically sealed 3-pin metal case
- With optimally coupled multimode-fiber pigtail

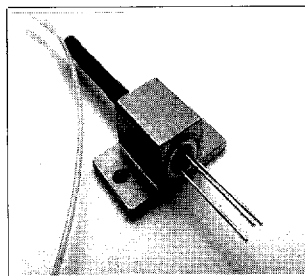

Type	Ordering Code	Connector/Flange
SRD 00514H	Q62702-Pxxxx	Pigtail, FC/PC-connector
SRD 00515H	Q62702-Pxxxx	Pigtail with flange, FC/PC-connector

Component with other connector types on request.

### Maximum Ratings

Parameter	Symbol	Values	Unit
Forward current	$I_F$	50	mA
Reverse voltage	$V_R$	*	V
Operating and storage temperature	$T_A$ $T_{stg}$	- 40 ... + 85	°C
Max. radiant power into the opt. port ( $V_R = 5$ V)	$\Phi_{port}$	1	mW
Soldering time (wave / dip soldering), distance between solder point and baseplate ( $\geq 2$ mm, 260 °C)	$t_s$	10	s

\* Individual value of  $V_{BR}$  is delivered with each component.

## Characteristics

All optical data refer to an optimally coupled 10/125  $\mu\text{m}$  SM fiber at ambient temperature of 25 °C, unless otherwise defined.

Parameter	Symbol	Values	Unit
Spectral sensitivity $\lambda = 1310 \text{ nm}, M = 1$	$S_\lambda$	0.8 ( $\geq 0.7$ )	A/W
Rise and fall time (10 % - 90 %) $R_L = 50 \Omega, M = 1, \lambda = 1310 \text{ nm}, \Phi_{\text{port}} = 100 \mu\text{W}$	$t_r; t_f$	0.3 ( $\leq 0.5$ )	ns
Multiplication factor at $V_R = 0.9 V_{BR}$	$M$	4 ( $\geq 3$ )	
Breakdown voltage $I_R = 100 \mu\text{A}$	$V_{BR}$	28 ... 40	V
Total capacitance $V_R = 0.9 V_{BR}, \Phi_{\text{port}} = 0, f = 1 \text{ MHz}$	$C$	$\leq 2$	pF
Dark current $V_R = 10 \text{ V}$ $V_R = 0.9 V_{BR}$	$I_D$	< 200 < 300	nA nA
Multiplied dark current ( $M = 10$ )	$I_{DM}$	$\leq 20$	nA

### Rel. Spectral Sensitivity

$M = 1 (V_R = 10 \text{ V})$

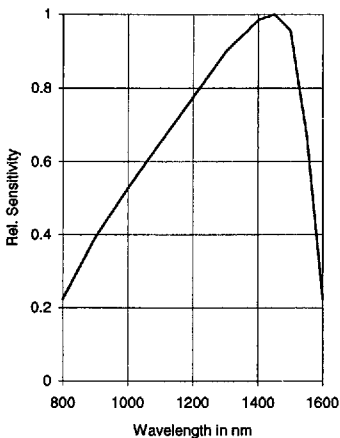

### Dark Current $I_D = I_D(V_R / V_{BR})$

Multiplication Factor  $M = M(V_R / V_{BR})$

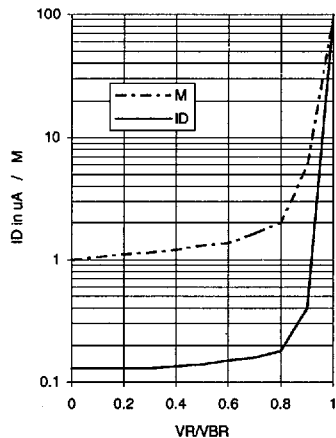

### Frequency Response of Sensitivity

$$S = S(f), \lambda = 1300 \text{ nm}$$

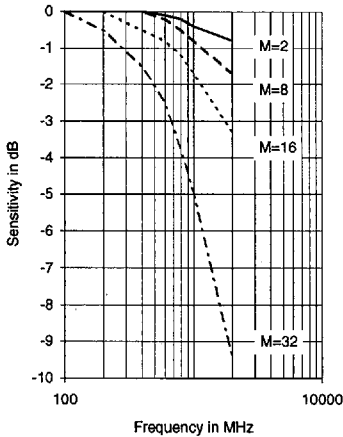

### Temperatur Behaviour of Breakdown Voltage

$$V_{BR} / V_{BR(25^\circ\text{C})}(T_A)$$

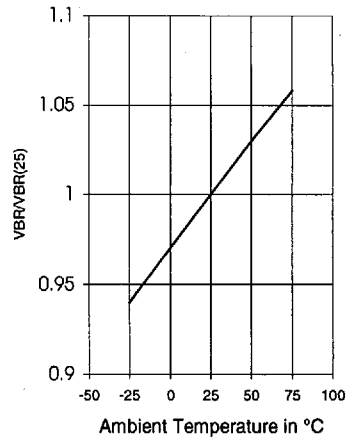

### Temperature Behaviour of Dark Current

$$I_D / I_{D(25^\circ\text{C})}(T_A)$$

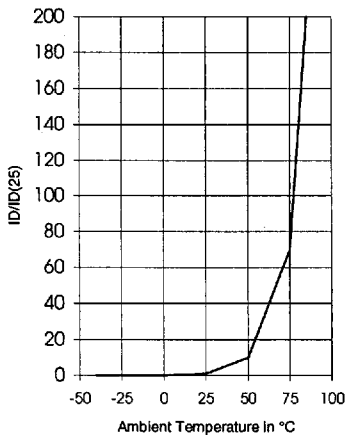

### Sensitivity at different input Powers

$$V_{BR} / V_{BR(25^\circ\text{C})}(T_A)$$

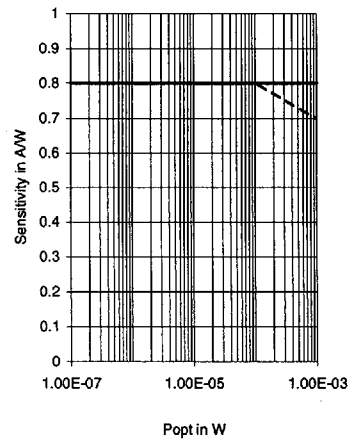

**Package Outlines (Dimensions in mm)**

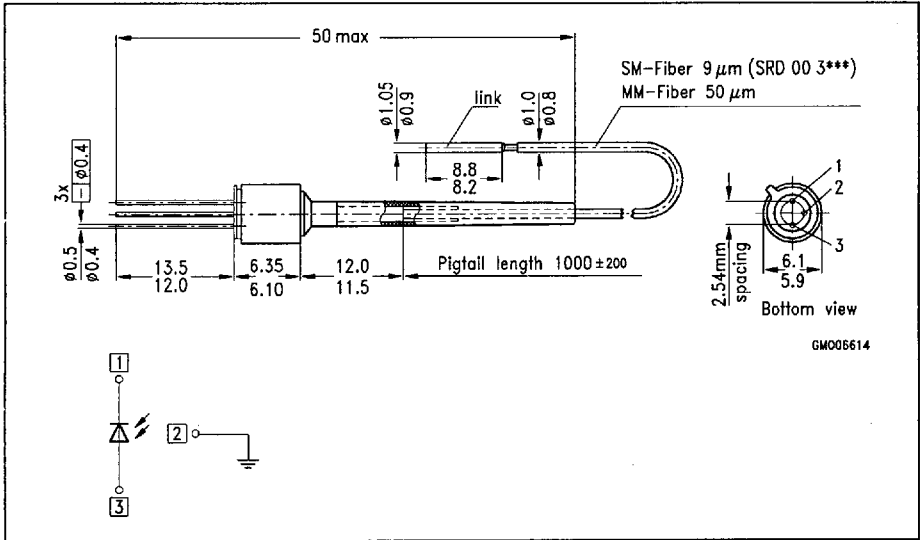

**SRD 00514X**

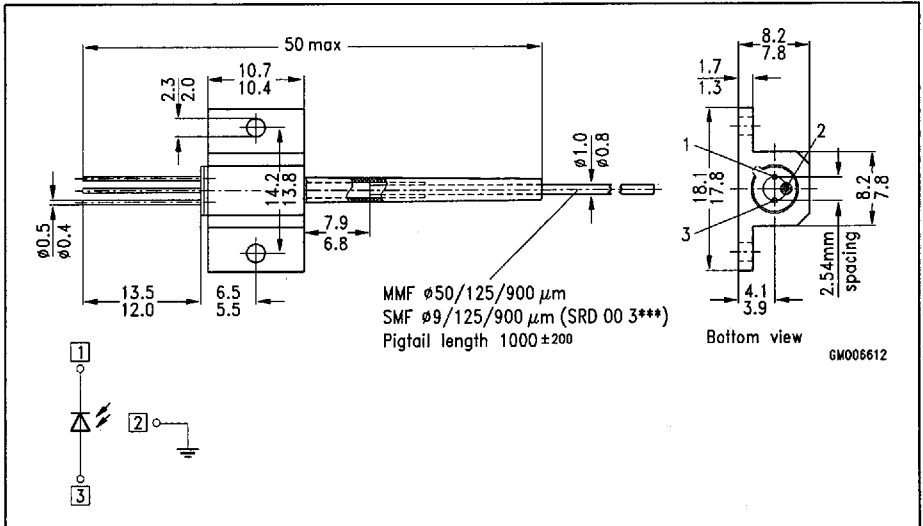

**SRD 00515X**