

Up to 800 mW Fiber Bragg Grating Stabilized Mini-Butterfly 980 nm Pump Modules

M29 Series

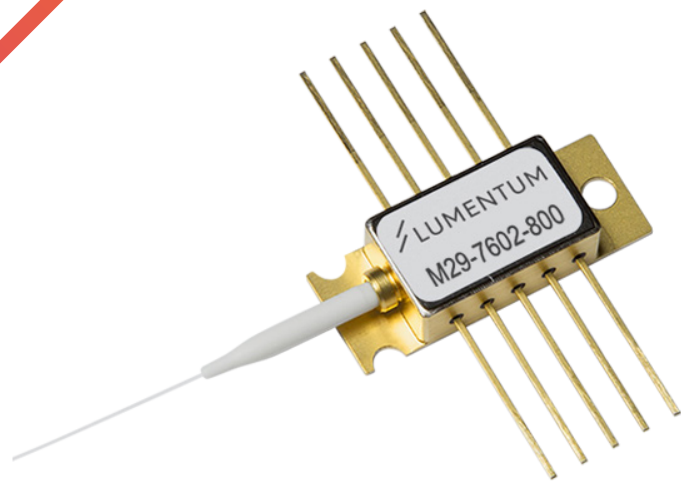

The Lumentum M29 Series 980 nm mini-butterfly pump laser module uses a number of revolutionary design steps and the very latest material technologies to significantly improve scalability of the production process. The M29 Series pump module incorporates the high-reliability Lumentum 980 nm laser diode in a 45°C fiber Bragg grating-stabilized 10-pin butterfly module. This ‘semicooled’ laser diode operation provides for a significant reduction in TEC and overall power consumption. The module meets the stringent requirements of the telecommunications industry, including Telcordia GR-468-CORE for hermetic 980nm pump modules.

The M29 Series pump module, which uses fiber Bragg grating stabilization to lock the emission wavelength, provides a noise-free, narrowband spectrum, even under changes in temperature, drive current and optical feedback. Wavelength selection is available for applications requiring the highest performance in spectrum control with the highest power available.

Key Features

- Operating power range from 100 – 800 mW
- 45°C internal temperature, reduced TEC power consumption
- Low-profile 10-PIN small form factor (mini-butterfly) package
- Fiber Bragg grating stabilization
- Wavelength selection available
- Integrated thermoelectric cooler, thermistor, and monitor diode
- High dynamic range

Applications

- Dense wavelength division multiplexing (DWDM) EDFAs for small package designs
- High bit-rate, high channel-count EDFAs
- CATV distribution

Compliance

- Telcordia GR-468-CORE

Dimensions Diagram

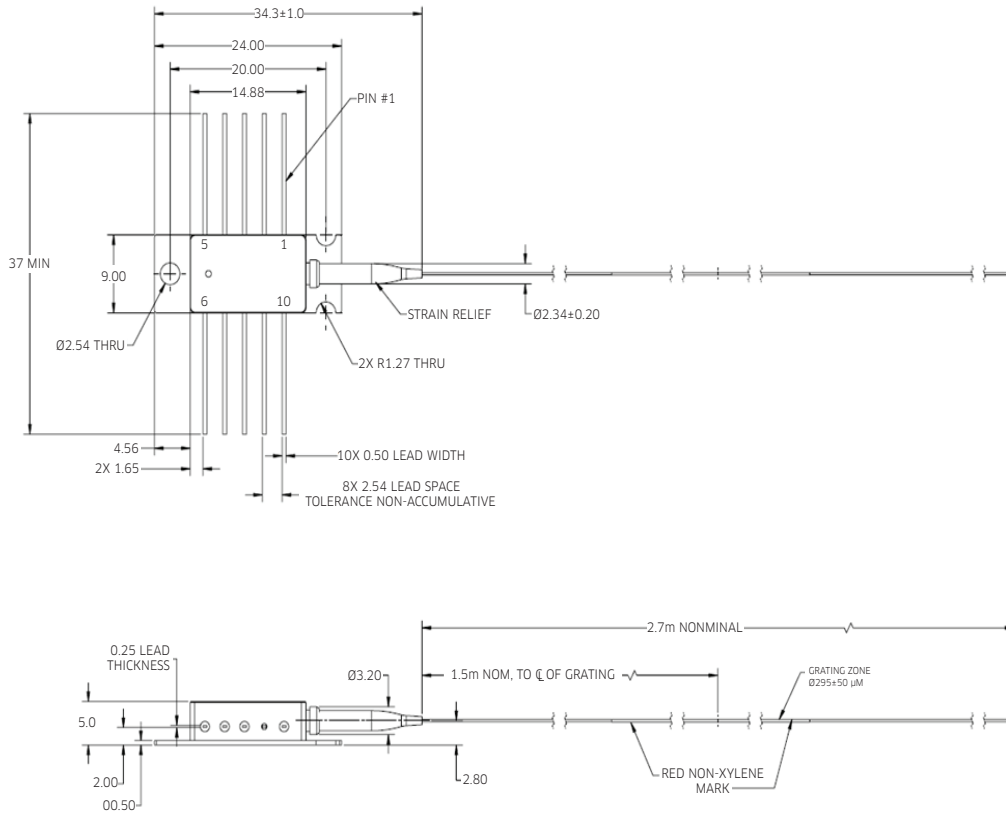

Pinout

Pin	Description
1	TEC (+)
2	Thermistor
3	Monitor Anode (-)
4	Monitor Cathode (+)
5	Thermistor
6	Laser Anode (+)
7	Laser Cathode (-)
8	NC
9	Pkg ground
10	TEC (-)

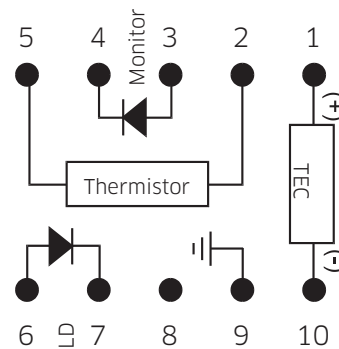

Table 1. Absolute Maximum Ratings

Parameter	Symbol	Test Conditions	Minimum	Maximum
Operating case temperature	T_{OP}		-5°C	75°C
Storage temperature	T_{STR}	2000 hr	-40°C	85°C
Laser operating temperature	T_{LD}		15°C	60°C
LD reverse voltage	V_r			2 V
LD forward current	$I_{r,max}$			1800 mA
LD current transient		20 μ s maximum		1900 mA
LD reverse current				10 μ A
PD reverse voltage	V_{PD}			20 V
PD forward current	I_{PF}			10 mA
LD electrostatic discharge (ESD)	V_{ESDLD}	C = 100 pF, R = 1.5 k Ω , HBM		1000 V
PD electrostatic discharge (ESD)	V_{ESDPD}	C = 100 pF, R = 1.5 k Ω , HBM		500 V
TEC current	I_{TEC}		-1.2 A	2 A
TEC voltage	V_{TEC}			4.5 V
Axial pull force		3 x 10 s		5 N
Side pull force		3 x 10 s		2.5 N
Fiber bend radius			16 mm	
Relative humidity	RH	Noncondensing	5%	95%
Lead soldering time		300°C		10 s

Absolute maximum ratings are the maximum stresses that may be applied to the module for short periods of time without causing damage and are listed in Table 5. Stresses in excess of the absolute maximum ratings can cause permanent damage to the device. Exposure to absolute maximum ratings for extended periods of time or exposure to more than one absolute maximum rating simultaneously may adversely affect device reliability. Specifications may not necessarily be met under these conditions.

Table 2. Operating Parameters (BOL, $T_{case} = -5$ to 75°C, -50 dB reflection, unless otherwise noted.)

Product Code	Maximum Operating Power P_{op} (mW)	Maximum Operating Current I_{op} (mA)	Minimum Kink-Free Power P_{max} (mW)	Maximum Kink-Free Current I_{max} (mA)
M29-xxxx-400	400	810	440	885
M29-xxxx-420	420	850	462	925
M29-xxxx-440	440	885	484	970
M29-xxxx-460	460	925	506	1010
M29-xxxx-480	480	960	528	1050
M29-xxxx-500	500	1000	550	1095
M29-xxxx-520	520	1035	572	1135
M29-xxxx-540	540	1065	594	1170
M29-xxxx-560	560	1095	616	1205
M29-xxxx-580	580	1125	638	1240
M29-xxxx-600	600	1155	660	1275
M29-xxxx-620	620	1195	682	1325
M29-xxxx-640	640	1235	704	1375
M29-xxxx-660	660	1275	726	1420
M29-xxxx-680	680	1320	748	1475
M29-xxxx-700	700	1365	770	1525
M29-xxxx-720	720	1410	792	1575
M29-xxxx-740	740	1455	814	1625
M29-xxxx-760	760	1500	836	1665
M29-xxxx-780	780	1545	858	1710
M29-xxxx-800	800	1590	880	1745

The xxxx denotes the wavelength per the product code in Table 3.

Table 3. Available Peak Wavelength Selection

Product Code	Minimum Center Wavelength	Maximum Center Wavelength
M29-7402-yyy	973.0 nm	975.0 nm
M29-7602-yyy	975.0 nm	977.0 nm
M29-8000-yyy	973.0 nm	981.5 nm

The yyy denotes the power per the product code in Table 2.

Table 4. Electro-Optical Performance (BOL, $T_{case} = -5^{\circ}C$ to $75^{\circ}C$, $T_{LD} = 45^{\circ}C$, $P_f = 30mW$ to P_{op} , $-50dB$ reflection, unless otherwise noted)

Parameter	Symbol	Test Conditions	Minimum	Maximum
Threshold current	I_{th-BOL}			100 mA
Forward voltage	V_f	$I_f = I_{op}$		2.1 V
Fiber output power range	P_f		30 mW	P_{op}
Pump power in band	P_{pump}	Pump Band = $\lambda_m \pm 1.5$ nm, at P_{op}	90%	
Spectral width	$\Delta\lambda_{RMS}$	Over P_f Range		2.0 nm
Wavelength tuning vs. temperature	$\Delta\lambda/T$	$I_f = I_{op}$		0.01 nm/ $^{\circ}C$
Optical power stability	$\Delta P_{f,t}$	Over P_f range, DC to -50 kHz, 50 mW $-P_{op}$		2.0%
Tracking ratio ¹	TR	$0.1P_{op} < P_f < P_{op}$	0.6	1.40
Tracking error ²	TE	P_{op}	-40%	80%
Monitor diode response	I_{BF}	-5 V Bias, at P_{op}	0.5 $\mu A/mW$	5 $\mu A/mW$
LD temperature	T_{LD}	Nominal $T_{LD} = 45^{\circ}C$	44 $^{\circ}C$	46 $^{\circ}C$
Thermistor resistance: M29-7402-yyy, M29-7602-yyy	R_{th}	$T_{set} = 45^{\circ}C$	9.5 k Ω	10.5 k Ω
Thermistor resistance: M29-8000-yyy	R_{th}	$T_{set} = 45^{\circ}C$	9.0 k Ω	11.5 k Ω

- The tracking ratio is a measure of the front-to-back tracking when the output power is varied. On a plot of optical power versus back-face photocurrent, a straight line is drawn between the minimum power (30 mW) and the operating power (P_{op}) points. The tracking ratio is defined as the ratio between measured optical power (shown as data points on the plot) to the value derived from the straight line.
- The tracking error is defined as the normalized change of output power relative to P_f at $25^{\circ}C$, i.e., $(P_f - P_{f,25})/P_{f,25}$, over case temperature range $0^{\circ}C$ to $75^{\circ}C$, at constant back-face monitor current corresponding to lowest back-face monitor current at $P_f = P_{op}$ of $0^{\circ}C$, $25^{\circ}C$, $75^{\circ}C$.

Table 5. TEC and Total Module Power Consumption at $T_{LD} = 45^{\circ}C$ (BOL, $\Delta T = 30^{\circ}C$, $T_{case} = 75^{\circ}C$)

Product Code	TEC Current I_{max} (A)	TEC Voltage V_{max} (V)	TEC Power Consumption P_{TEC} (W)	Total Module Power Consumption P_{max} (W)
M29-xxxx-400	0.62	1.77	1.10	2.39
M29-xxxx-420	0.63	1.78	1.13	2.49
M29-xxxx-440	0.64	1.80	1.15	2.58
M29-xxxx-460	0.65	1.82	1.18	2.69
M29-xxxx-480	0.66	1.84	1.21	2.78
M29-xxxx-500	0.67	1.85	1.24	2.89
M29-xxxx-520	0.68	1.87	1.28	3.00
M29-xxxx-540	0.69	1.89	1.31	3.10
M29-xxxx-560	0.70	1.92	1.35	3.20
M29-xxxx-580	0.72	1.94	1.39	3.30
M29-xxxx-600	0.73	1.96	1.42	3.41
M29-xxxx-620	0.74	1.98	1.47	3.54
M29-xxxx-640	0.75	2.00	1.51	3.66
M29-xxxx-660	0.77	2.03	1.56	3.80
M29-xxxx-680	0.78	2.06	1.62	3.95
M29-xxxx-700	0.80	2.09	1.67	4.10
M29-xxxx-720	0.82	2.11	1.72	4.26
M29-xxxx-740	0.83	2.14	1.78	4.42
M29-xxxx-760	0.85	2.17	1.84	4.59
M29-xxxx-780	0.87	2.20	1.92	4.76
M29-xxxx-800	0.89	2.24	1.98	4.94

Table 6. HI 1060 Fiber Nominal Characteristics and Tolerances

Parameters	Specification
Cutoff wavelength	920 nm
Maximum attenuation at 980 nm	2.1 dB/km
Cladding outside diameter	125 ±1 μm
Coating outside diameter	245 ±10 μm
Core-cladding concentricity	≤0.5 μm
Mode field diameter	5.9 ±0.3 μm

User Safety

Safety and Operating Considerations

The laser light emitted from this laser diode is invisible and may be harmful to the human eye. Avoid looking directly into the fiber when the device is in operation.

CAUTION: THE USE OF OPTICAL INSTRUMENTS WITH THIS PRODUCT INCREASES EYE HAZARD.

Operating the laser diode outside of its maximum ratings may cause device failure or a safety hazard. Power supplies used with this component cannot exceed maximum peak optical power.

CW laser diodes may be damaged by excessive drive current or switching transients. When using power supplies, the laser diode should be connected with the main power on and the output voltage at zero. The current should be increased slowly while monitoring the laser diode output power and the drive current. Careful attention to heatsinking and proper mounting of this device is required to ensure specified performance over its operating life. To maximize thermal transfer to the heatsink, the heatsink mounting surface must be flat to within .001inch and the mounting screws must be torqued down to 1.5 in/lb.

ESD PROTECTION—Electrostatic discharge (ESD) is the primary cause of unexpected laser diode failure. Take extreme precaution to prevent ESD. Use wrist straps, grounded work surfaces, and rigorous antistatic techniques when handling laser diodes.

Labeling

Laser Safety

The Lumentum pump laser module emits hazardous invisible laser radiation. Due to the small size of the pump module, the box packaging is labeled with the laser radiation hazard symbol and safety warning labels shown below.



10-pin module label

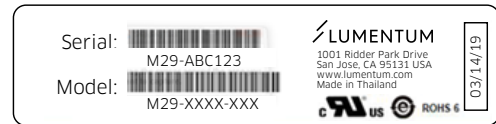

Shipping box label

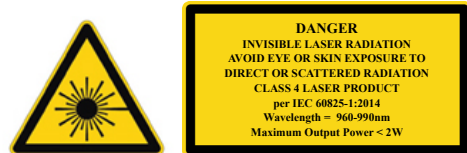

Output power and laser emission indicator label

Ordering Information

For more information on this or other products and their availability, please contact your local Lumentum account manager or Lumentum directly at customer.service@lumentum.com.

M29 -

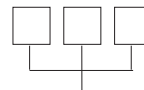
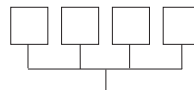

Peak Wavelength	Code
973.0 to 975.0 nm	7402
975.0 to 977.0 nm	7602
973.0 to 981.5 nm	8000

Maximum Operating Power	Code
400 mW	400
420 mW	420
440 mW	440
460 mW	460
480 mW	480
500 mW	500
520 mW	520
540 mW	540
560 mW	560
580 mW	580
600 mW	600
620 mW	620
640 mW	640
660 mW	660
680 mW	680
700 mW	700
720 mW	720
740 mW	740
760 mW	760
780 mW	780
800 mW	800



North America
Toll Free: 844 810 LITE (5483)

Outside North America
Toll Free: 800 000 LITE (5483)

China
Toll Free: 400 120 LITE (5483)

© 2020 Lumentum Operations LLC
Product specifications and descriptions in this document are subject to change without notice.