

SANYO

No. ※4541A

LC331632M-70/80/10/12, ML-70/80/10**512 K (32768 words × 16 bits) Pseudo-SRAM****Preliminary****Overview**

The LC331632 series is composed of pseudo static RAM that operate on a single 5 V power supply and are organized as 32768 words × 16 bits. By using memory cells each composed of a single transistor and capacitor, together with peripheral CMOS circuitry, this series achieves ease of use with high density, high speed, and low power dissipation. The LC331632 series can easily accomplish auto-refresh by means of $\overline{LOE}/\overline{RFSH}$ input. The available package is the 40-pin SOP with a width of 525 mil.

Features

- 32768 words × 16 bits configuration
- \overline{CE} access time, \overline{OE} access time, cycle time and current dissipation

Package Dimensions

unit: mm

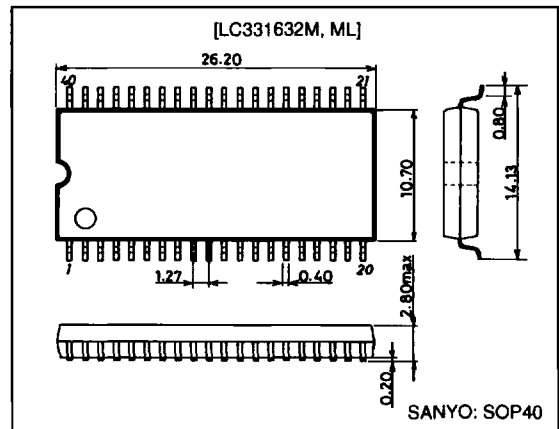
3195-SOP40

Parameter		LC331632M, ML			
		-70	-80	-10	-12
\overline{CE} access time		70 ns	80 ns	100 ns	120 ns
\overline{OE} access time		35 ns	40 ns	50 ns	75 ns
Cycle time		115 ns	130 ns	160 ns	210 ns
Current dissipation	Operating	100 mA	90 mA	75 mA	65 mA
	Standby	2 mA/100 μ A (L version)			

- Single 5 V $\pm 10\%$ power supply
- All input and output (I/O) TTL compatible
- Fast access time and low power dissipation
- 4 ms refresh using 256 refresh cycles
- Supports \overline{CE} -only refresh and auto-refresh
- Supports byte unit read and write operations using the $\overline{LOE}/\overline{RFSH}$ and \overline{UOE} inputs or the \overline{LWE} and \overline{UWE} inputs.
- Low-power version: 100 μ A standby current
- 40-pin SOP plastic package

Block Diagram

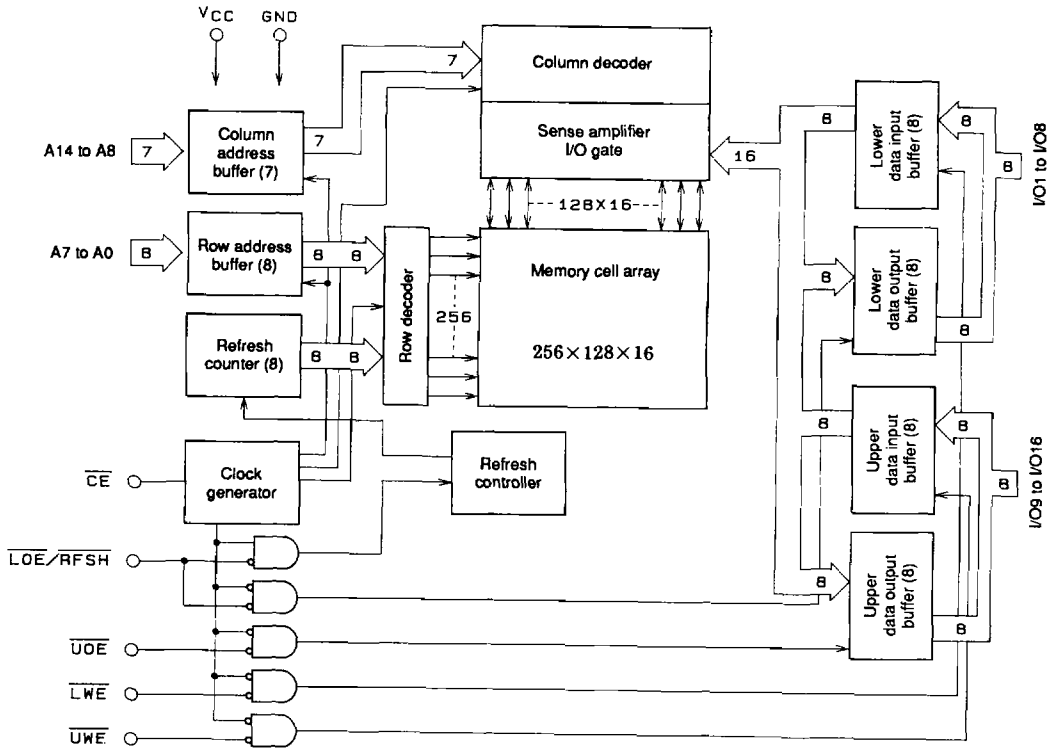

A01587

Pin Assignment

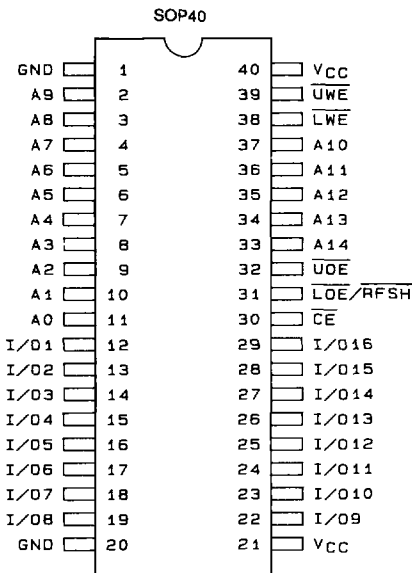

Top View

Pin Functions

A0 to A14	Address input
LWE	Lower byte write enable input
UWE	Upper byte write enable input
LOE/RFSH	Lower byte output enable input/refresh input
UOE	Upper byte output enable input
CE	Chip enable input
I/O1 to I/O8	Lower byte data input/output
I/O9 to I/O16	Upper byte data input/output
V _{CC}	Power supply
GND	Ground

Functional Logic

\overline{CE}	$\overline{LOE}/\overline{RFSH}$	\overline{UOE}	\overline{LWE}	\overline{UWE}	A0 to 7	A8 to 14	I/O1 to 8	I/O9 to 16	State
H	H	X	X	X	X	X	HZ	HZ	Standby
L	L	L	H	H	VX	VX	OUT	OUT	Read (word)
L	L	H	H	H	VX	VX	OUT	HZ	Read (lower byte)
L	H	L	H	H	VX	VX	HZ	OUT	Read (upper byte)
L	H	H	L	L	VX	VX	IN	IN	Write (word)
L	H	H	L	H	VX	VX	IN	HZ	Write (lower byte)
L	H	H	H	L	VX	VX	HZ	IN	Write (upper byte)
L	H	H	H	H	VX	X	HZ	HZ	\overline{CE} -only refresh
H	NP	X	X	X	X	X	HZ	HZ	Auto-refresh

H: High-level input of $V_{IN} = 6.5\text{ V}$ to V_{IH} (min)
 L: Low-level input of $V_{IN} = V_{IL}$ (max) to -1.0 V
 X: High- or low-level input
 NP: Negative-polarity pulse input
 VX: "IN" when $\overline{CE} = L$ is confirmed, then "X"
 HZ: High impedance
 IN: Input state
 OUT: Output state

Specifications

Absolute Maximum Ratings

Parameter	Symbol	Ratings	Unit	Note
Maximum supply voltage	$V_{CC\text{ max}}$	-1.0 to $+7.0$	V	1
Input voltage	V_{IN}	-1.0 to $+7.0$	V	1
Output voltage	V_{OUT}	-1.0 to $+7.0$	V	1
Allowable power dissipation	$P_{d\text{ max}}$	600	mW	1
Output short current	I_{OUT}	50	mA	1
Operating temperature range	T_{opr}	0 to $+70$	$^{\circ}\text{C}$	1
Storage temperature range	T_{stg}	-55 to $+150$	$^{\circ}\text{C}$	1

Note: 1. Stresses greater than the above listed maximum values may result in damage to the device.

DC Recommended Operating Ranges at $T_a = 0$ to $+70^{\circ}\text{C}$

Parameter	Symbol	min	typ	max	Unit	Note
Power supply voltage	V_{CC}	4.5	5.0	5.5	V	2
Input high level voltage	V_{IH}	2.4		6.5	V	2
Input low level voltage	V_{IL}	-1.0		+0.8	V	2

Note: 2. All voltages are referenced to GND.

DC Electrical Characteristics at $T_a = 0$ to $+70^{\circ}\text{C}$, $V_{CC} = 5\text{V} \pm 10\%$

Parameter	Symbol	Conditions	min	max	Unit	Note
Operating current (Average current during operation)	I_{CCA}	Cycle time	115 ns	100	mA	3, 4
			130 ns	90		
			160 ns	75		
			210 ns	65		
Standby current 1	I_{CCS1}	$\overline{CE} = \overline{LOE}/\overline{RFSH} = V_{IH}$	LC331632M	3	mA	
			LC331632ML	1	mA	
Standby current 2	I_{CCS2}	$\overline{CE} = \overline{LOE}/\overline{RFSH} = V_{CC} - 0.2\text{ V}$	LC331632M	2	mA	
			LC331632ML	100	μA	
Input leakage current	I_{IL}	$0\text{ V} \leq V_{IN} \leq V_{CC}$, pins other than measuring pin = 0 V	-10	+10	μA	
Output leakage current	I_{OL}	Output disable, $0\text{ V} \leq V_{OUT} \leq V_{CC}$	-10	+10	μA	
Output high level voltage	V_{OH}	$I_{OUT} = -1\text{ mA}$	2.4		V	
Output low level voltage	V_{OL}	$I_{OUT} = 4.2\text{ mA}$		0.4	V	

Note: 3. All current values are measured at minimum cycle rate. Since current flows immoderately, if cycle time is longer than shown here, current value becomes smaller. A bypass capacitor of $0.01\ \mu\text{F}$ or larger should be inserted between V_{CC} and GND for each memory chip to suppress power supply noise (voltage drops) due to transient currents.

4. Dependent on output load. Maximum value is value during free state.

LC331632M, ML

Capacitance Characteristics at $T_a = 25^\circ\text{C}$, $f = 1\text{ MHz}$, $V_{CC} = 5\text{ V} \pm 10\%$

Parameter	Symbol	Measuring Conditions	min	max	Unit
Input capacitance (A0 to A14)	C_{IN1}	$V_{IN1} = 0\text{ V}$		5	pF
Input capacitance ($\overline{\text{CE}}$, $\overline{\text{LOE}}$ / $\overline{\text{RFSH}}$, $\overline{\text{UOE}}$, $\overline{\text{LWE}}$, $\overline{\text{UWE}}$)	C_{IN2}	$V_{IN2} = 0\text{ V}$		7	pF
I/O capacitance	C_{IO}	$V_{IO} = 0\text{ V}$		10	pF

Sampling inspections, and not full-lot inspections, are carried out for these parameters.

AC Recommended Operating Ranges at $T_a = 0$ to $+70^\circ\text{C}$, $V_{CC} = 5\text{ V} \pm 10\%$ (Notes 5, 6, 7, 8, 9)

Parameter	Symbol	-70		-80		-10		-12		Unit	Note
		min	max	min	max	min	max	min	max		
Random read or write cycle time	t_{RC}	115		130		160		210		ns	
$\overline{\text{CE}}$ pulse width	t_{CE}	70	10000	80	10000	100	10000	120	10000	ns	
$\overline{\text{CE}}$ precharge time	t_p	35		40		50		80		ns	
$\overline{\text{CE}}$ access time	t_{CEA}		70		80		100		120	ns	
$\overline{\text{LOE}}$, $\overline{\text{UOE}}$ access time	t_{OEA}		35		40		50		75	ns	
$\overline{\text{CE}}$ output enable time	t_{CLZ}	10		10		10		10		ns	
$\overline{\text{LOE}}$, $\overline{\text{UOE}}$ output enable time	t_{OLZ}	0		0		0		0		ns	
$\overline{\text{CE}}$ output disable time	t_{CHZ}	0	20	0	25	0	30	0	35	ns	10
$\overline{\text{LOE}}$, $\overline{\text{UOE}}$ output disable time	t_{OHZ}	0	20	0	25	0	30	0	35	ns	10
$\overline{\text{LOE}}$, $\overline{\text{UOE}}$ hold time for $\overline{\text{CE}}$	t_{OHC}	0		0		0		0		ns	
$\overline{\text{LOE}}$, $\overline{\text{UOE}}$ setup time for $\overline{\text{CE}}$	t_{OSC}	10		10		10		10		ns	
Read command setup time	t_{RCS}	0		0		0		0		ns	
Read command hold time	t_{RCH}	0		0		0		0		ns	
Write pulse width	t_{WP}	25		30		35		85		ns	
Write command hold time	t_{WCH}	55		60		65		85		ns	
Write command lead time	t_{CWL}	40		45		50		85		ns	
Input data setup time for $\overline{\text{LWE}}$, $\overline{\text{UWE}}$	t_{DSW}	25		30		35		50		ns	11
Input data setup time for $\overline{\text{CE}}$	t_{DSC}	25		30		35		50		ns	11
Input data hold time for $\overline{\text{LWE}}$, $\overline{\text{UWE}}$	t_{DHW}	0		0		0		0		ns	11
Input data hold time for $\overline{\text{CE}}$	t_{DHC}	0		0		0		0		ns	11
Address setup time for $\overline{\text{CE}}$	t_{ASC}	0		0		0		0		ns	12
Address hold time for $\overline{\text{CE}}$	t_{AHC}	15		20		25		30		ns	12
Auto-refresh cycle time	t_{FC}	115		130		160		210		ns	
$\overline{\text{RFSH}}$ delay time for $\overline{\text{CE}}$	t_{RFD}	35		40		50		60		ns	
$\overline{\text{RFSH}}$ pulse width (Auto-refresh)	t_{FAP}	75	8000	80	8000	80	8000	80	8000	ns	13
$\overline{\text{RFSH}}$ precharge time (Auto-refresh)	t_{FP}	30		30		30		30		ns	13
$\overline{\text{RFSH}}$ active $\overline{\text{CE}}$ delay time (Auto-Refresh)	t_{FCE}	135		160		190		225		ns	13
Refresh time	t_{REF}		4		4		4		4	ms	
Rise or fall time	t_T	3	50	3	50	3	50	3	50	ns	

Note: 5. To accomplish internal initialization, $\overline{\text{CE}}$ and $\overline{\text{LOE}}$ / $\overline{\text{RFSH}}$ are fixed at V_{IH} for an interval of 1 ms when V_{CC} reaches the specified voltage after power is switched on. At least eight dummy cycles must be executed following that period.

6. Measured at $t_T = 5\text{ ns}$.
7. When measuring input signal timing, V_{IH} (min) and V_{IL} (max) are reference levels.
8. Measured using an equivalent of 100 pF and two standard TTL loads.
9. $\overline{\text{LOE}}$ / $\overline{\text{RFSH}}$ input functions as lower byte output enable input ($\overline{\text{LOE}}$) when $\overline{\text{CE}} = V_{IL}$, and as refresh input ($\overline{\text{RFSH}}$) when $\overline{\text{CE}} = V_{IH}$.
10. t_{CHZ} and t_{OHZ} are defined as the time until output enters the open circuit state and the output voltage level becomes immeasurable.
11. As with ordinary static RAM, write data is incorporated at the rise of $\overline{\text{LWE}}$, $\overline{\text{UWE}}$ input or $\overline{\text{CE}}$ input, whichever is earlier, and write data is therefore held during t_{DSW} , t_{DSC} , t_{DHW} , or t_{DHC} .
12. Because address input is incorporated at the fall of $\overline{\text{CE}}$, the address is maintained during t_{ASC} or t_{AHC} .
13. After auto-refresh has completed, $\overline{\text{CE}}$ must not be made active until the t_{FCE} period has elapsed.

Timing Chart

Read Cycle (word)

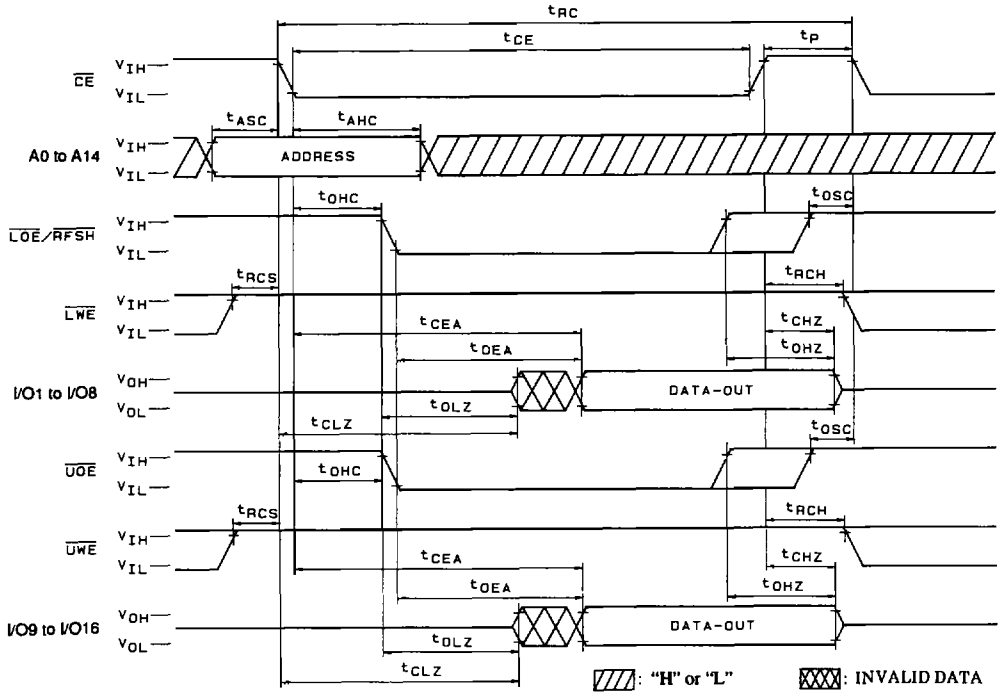

A01589

Read Cycle (lower byte)

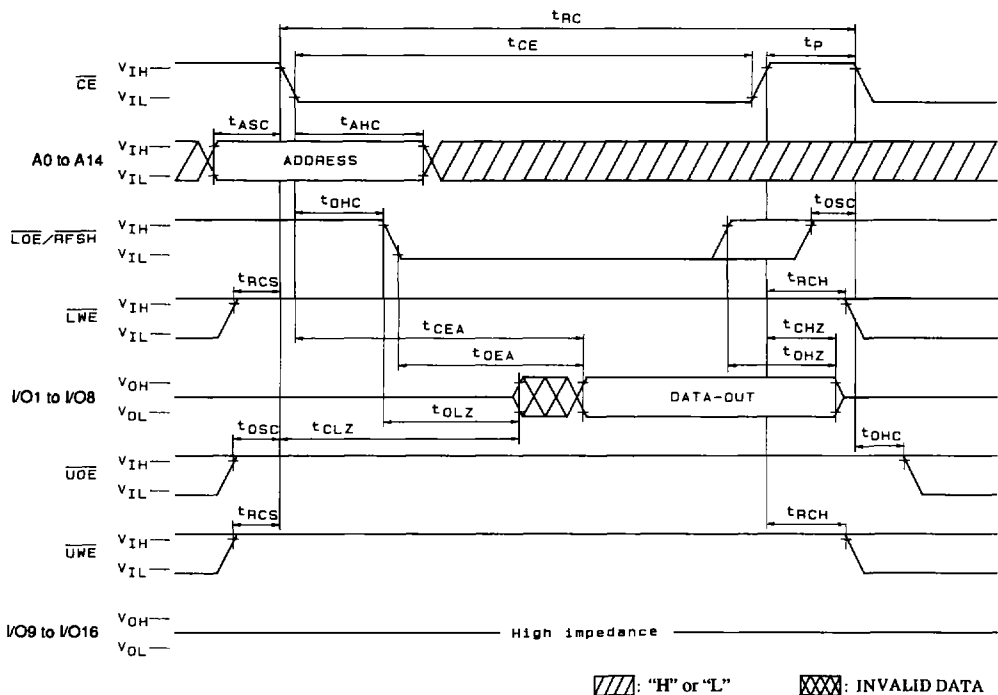

A01590

Read Cycle (upper byte)

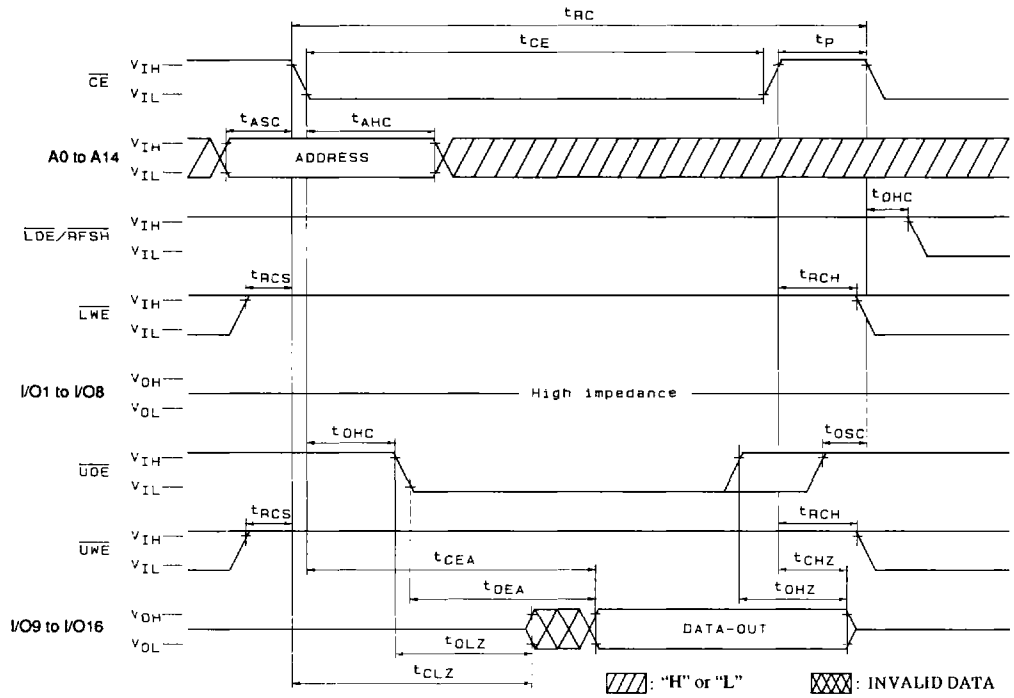

A01591

Write Cycle (word)

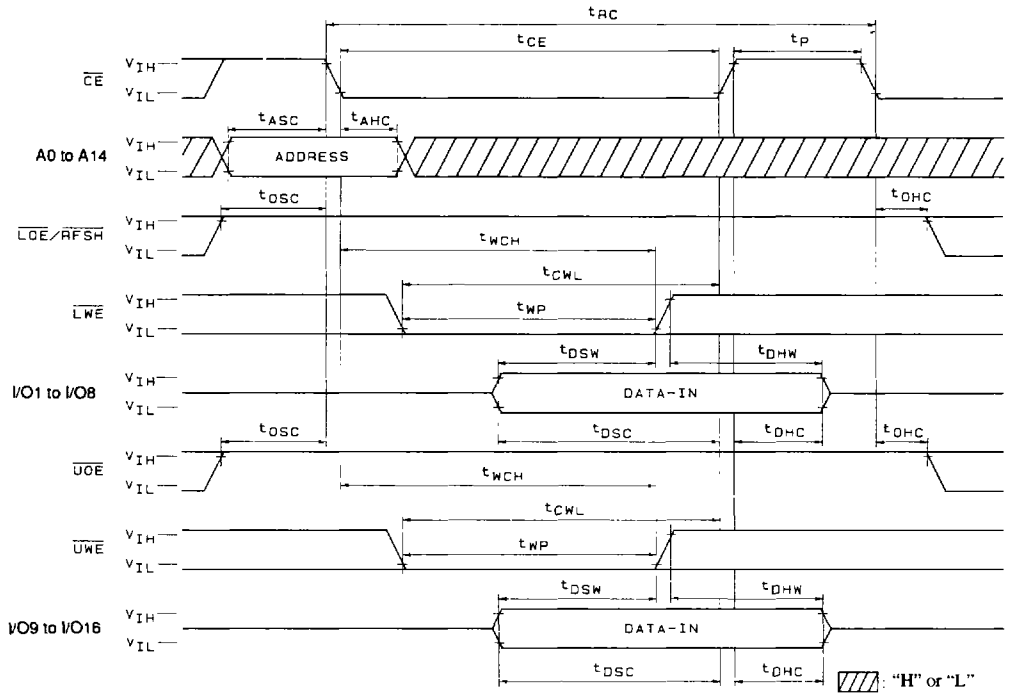

A01592

Write Cycle (lower byte)

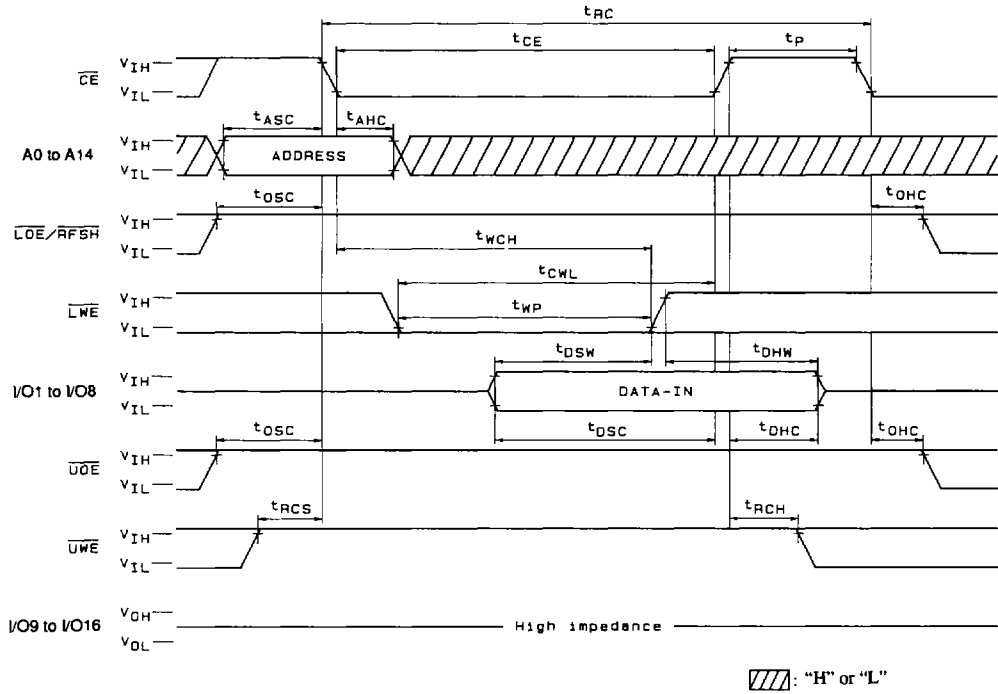

A01593

Write Cycle (upper byte)

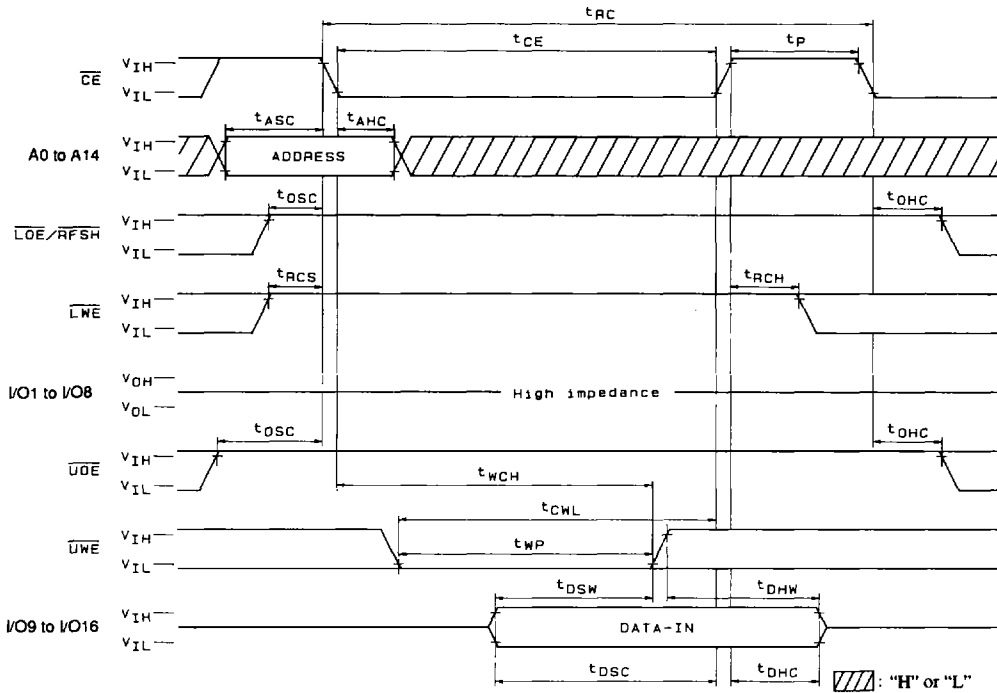

A01594

CE-Only Refresh Cycle

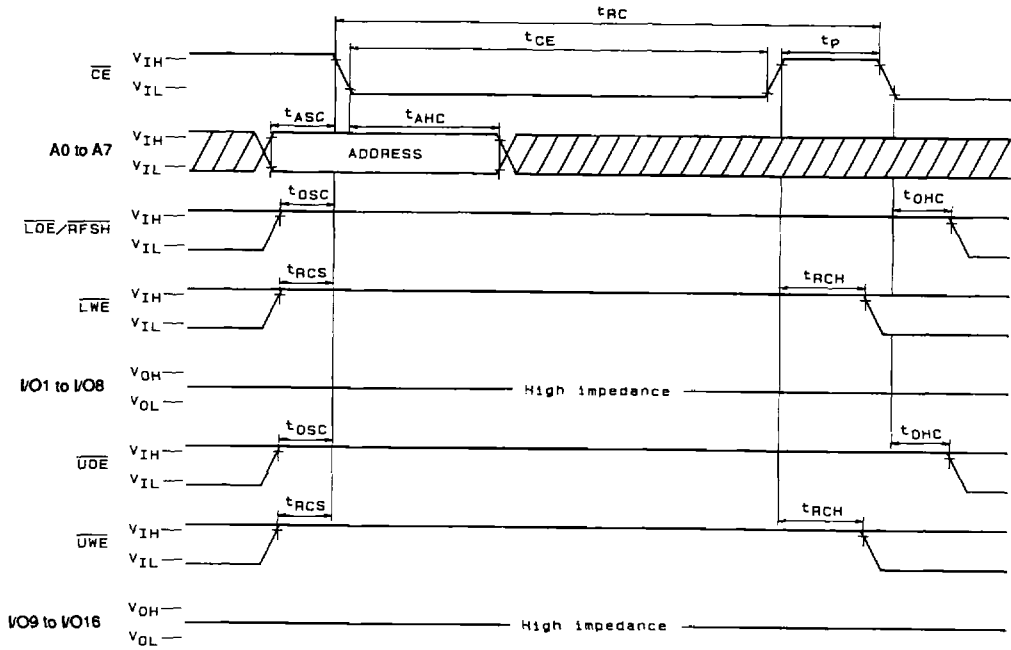

Note: A8 to A14 = "H" or "L"

▨: "H" or "L"

A01595

Auto-Refresh Cycle

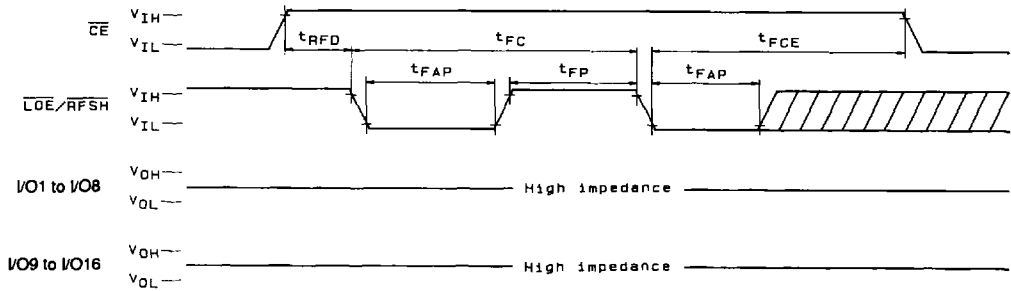

Note: A0 to A14, UOE, LWE, UWE = "H" or "L"

▨: "H" or "L"

A01596