



SANYO Semiconductors

DATA SHEET

STK433-090-E — Thick-Film Hybrid IC 2-channel class AB audio power IC, 80W+80W

Overview

The STK433-090-E is a hybrid IC designed to be used in 80W × 2ch class AB audio power amplifiers.

Applications

- Audio power amplifiers.

Features

- Pin-to-pin compatible outputs ranging from 80W to 150W.
- Can be used to replace the STK433-000 series (30W to 60W × 2ch) and STK433-200/-300 series (3-channel) due to its pin compatibility.
- Miniature package (67.0mm × 25.6mm × 9.0mm)
- Output load impedance: $R_L = 6\Omega$ supported
- Allowable load shorted time: 0.3 second
- Allows the use of predesigned applications for standby and mute circuits.

Series Models

	STK433-090-E	STK433-100-E	STK433-120-E	STK433-130-E
Output 1 (10%/1kHz)	80W×2ch	100W×2ch	120W×2ch	150W×2ch
Output 2 (0.4%/20Hz to 20kHz)	50W×2ch	60W×2ch	80W×2ch	100W×2ch
Max. rated V_{CC} (quiescent)	±54V	±57V	±65V	±71.5V
Max. rated V_{CC} (6Ω)	±47V	±50V	±57V	±63V
Recommended operating V_{CC} (6Ω)	±33V	±35V	±40V	±44V
Dimensions (excluding pin height)	67.0mm×25.6mm×9.0mm			

■ Any and all SANYO Semiconductor Co.,Ltd. products described or contained herein are, with regard to "standard application", intended for the use as general electronics equipment (home appliances, AV equipment, communication device, office equipment, industrial equipment etc.). The products mentioned herein shall not be intended for use for any "special application" (medical equipment whose purpose is to sustain life, aerospace instrument, nuclear control device, burning appliances, transportation machine, traffic signal system, safety equipment etc.) that shall require extremely high level of reliability and can directly threaten human lives in case of failure or malfunction of the product or may cause harm to human bodies, nor shall they grant any guarantee thereof. If you should intend to use our products for applications outside the standard applications of our customer who is considering such use and/or outside the scope of our intended standard applications, please consult with us prior to the intended use. If there is no consultation or inquiry before the intended use, our customer shall be solely responsible for the use.

■ Specifications of any and all SANYO Semiconductor Co.,Ltd. products described or contained herein stipulate the performance, characteristics, and functions of the described products in the independent state, and are not guarantees of the performance, characteristics, and functions of the described products as mounted in the customer's products or equipment. To verify symptoms and states that cannot be evaluated in an independent device, the customer should always evaluate and test devices mounted in the customer's products or equipment.

STK433-090-E

Specifications

Absolute maximum ratings at $T_a=25^{\circ}\text{C}$ (excluding rated temperature items), $T_c=25^{\circ}\text{C}$ unless otherwise specified

Parameter	Symbol	Conditions	Ratings	Unit
Maximum quiescent supply voltage 0	V_{CC} max (0)	When no signal	± 54	V
Maximum supply voltage 1	V_{CC} max (1)	$R_L \geq 6\Omega$	± 47	V
Minimum operating supply voltage	V_{CC} min		± 10	V
Maximum operating flow-in current (pin 13) *7	IST OFF max		0.6	mA
Thermal resistance	θ_{j-c}	Per power transistor	2.1	$^{\circ}\text{C}/\text{W}$
Junction temperature	T_j max	Both the T_j max and T_c max conditions must be met.	150	$^{\circ}\text{C}$
IC substrate operating temperature	T_c max		125	$^{\circ}\text{C}$
Storage temperature	T_{stg}		-30 to +125	$^{\circ}\text{C}$
Allowable load shorted time *4	t_s	$V_{CC}=\pm 33\text{V}$, $R_L=6\Omega$, $f=50\text{Hz}$, $P_O=50\text{W}$, 1-channel active	0.3	s

Operating Characteristics at $T_c=25^{\circ}\text{C}$, $R_L=6\Omega$, $R_g=600\Omega$, $V_G=30\text{dB}$, non-inductive load R_L , unless otherwise specified

Parameter	Symbol	Conditions *2					Ratings			unit
		V_{CC} (V)	f (Hz)	P_O (W)	THD (%)		min	typ	max	
Output power *1	P_O (1)	± 33	20 to 20k		0.4		47	50		W
	P_O (2)	± 33	1k		10			80		
Total harmonic distortion *1	THD (1)	± 33	20 to 20k	5.0		$V_G=30\text{dB}$			0.4	%
	THD (2)	± 33	1k					0.01		
Frequency characteristics *1	f_L, f_H	± 33		1.0		+0 -3dB	20 to 50k			Hz
Input impedance	r_i	± 33	1k	1.0			55			$k\Omega$
Output noise voltage *3	V_{NO}	± 39				$R_g=2.2k\Omega$			1.0	mVrms
Quiescent current	I_{CCO}	± 39				No loading	20	45	80	mA
Output neutral voltage	V_N	± 39					-70	0	+70	mV
Current flowing into pin13 in standby mode *7	IST ON	± 33				Voltage at pin13: 5V, Current limiting resistance R1: 13k Ω			0	mA
Current flowing into pin13 in operating mode *7	IST OFF	± 33					0.25		0.6	mA

[Remarks]

- *1: For 1-channel operation
- *2: Unless otherwise specified, use a constant-voltage power supply to supply power when inspections are carried out.
- *3: The output noise voltage values shown are peak values read with a VTVM. However, an AC stabilized (50Hz) power supply should be used to minimize the influence of AC primary side flicker noise on the reading.
- *4: Use the designated transformer power supply circuit shown in the figure below for the measurement of allowable load shorted time and output noise voltage.
- *5: Please connect -Pre V_{CC} pin (#1 pin) with the stable minimum voltage and connect so that current does not flow in by reverse bias.
- *6: Thermal design must be implemented based on the conditions under which the customer's end products are expected to operate on the market.
- *7: Be sure to use the current limiting resistor to prevent the current flowing into the standby pin (pin13) never exceeds the maximum rated value in operating mode.
The circuit is turned on by applying V_{BE} (approximately 0.6V) or higher voltage to the standby pin (pin13).
- *8: A thermoplastic adhesive resin is used for this hybrid IC.

Designated transformer power supply (MG-200 equivalent)

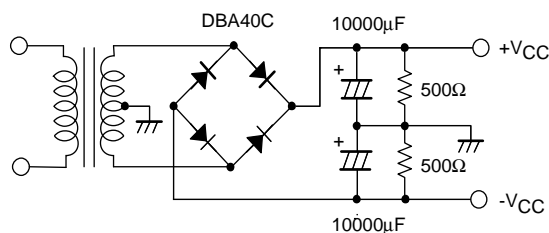

STK433-090-E

Package Dimensions

unit:mm (typ)

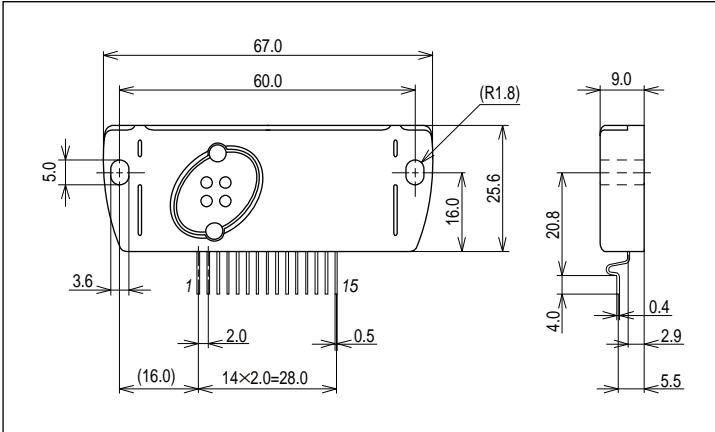

Internal Equivalent Circuit

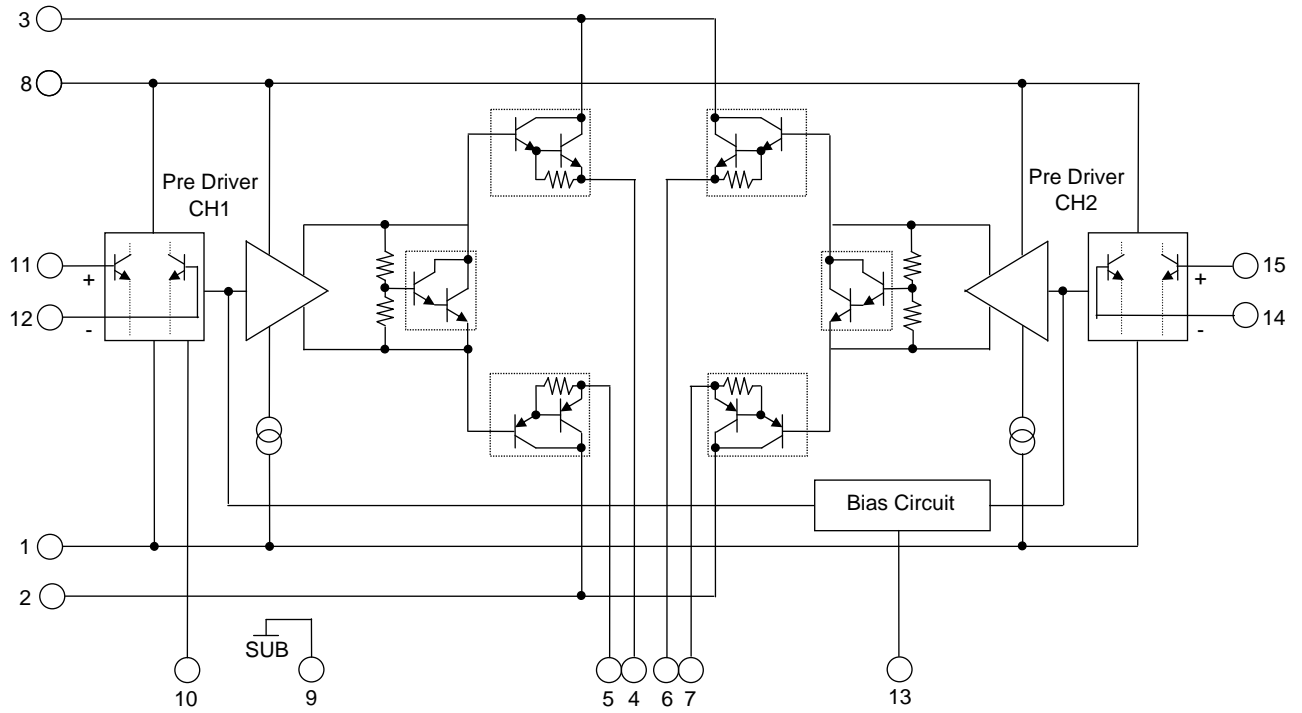

STK433-090-E

Application Circuit Example

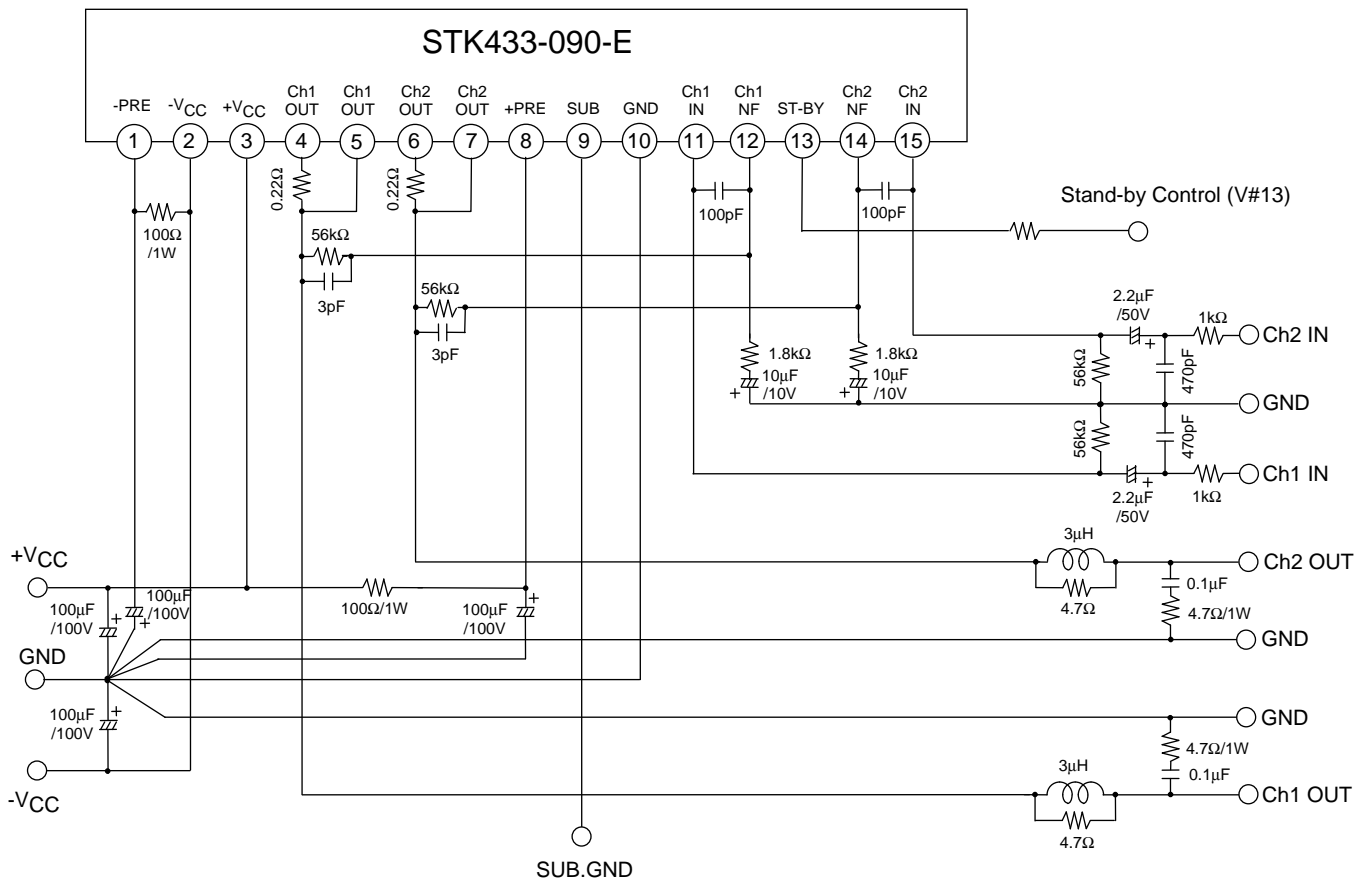

Sample PCB Trace Pattern

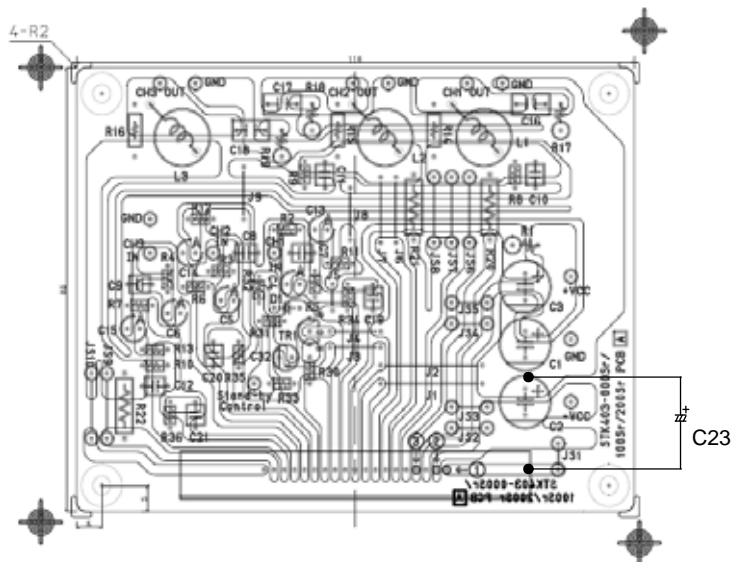

STK433-090-E

STK433-100/STK433-300Sr PCB PARTS LIST

PCB Name: STK403-000Sr/100Sr/200Sr PCBA

Location No. * 2ch AMP doesn't mount parts of ().	PARTS	RATING	Component		
Hybrid IC#1 Pin Position	-	-	①		
			STK433-100Sr (*2)	STK433-300Sr	
R01	ERG1SJ101	100Ω, 1W	enabled		
R02, R03 (R4)	RN16S102FK	1kΩ, 1/6W	enabled		
R05, R06, R08, R09 (R7, R10)	RN16S563FK	56kΩ, 1/6W	enabled		
R11, R12 (R13)	RN16S182FK	1.8kΩ, 1/6W	enabled		
R14, R15 (R16)	RN14S4R7FK	4.7Ω, 1/4W	enabled		
R17, R18 (R19)	ERX1SJ4R7	4.7Ω, 1W	enabled		
R20, R21 (R22)	Metal-plate Resistor is recommended	0.22Ω, 5W	enabled		
C01, C02, C03, C23 (*3)	100MV100HC	100μF, 100V	enabled		
C04, C05 (C06)	50MV2R2HC	2.2μF, 50V	enabled (*1)		
C07, C08 (C09)	DD104-63B471K50	470pF, 50V	enabled		
C10, C11 (C12)	DD104-63CJ030C50	3pF, 50V	enabled		
C13, C14 (C15)	10MV10HC	10μF, 10V	enabled (*1)		
C16, C17 (C18)	ECQ-V1H104JZ	0.1μF, 50V	enabled		
C19, C20 (C21)	DD104-63B***K50	***pF, 50V	100pF	68pF	
R34, R35 (R36)	RN16S302FK	3kΩ, 1/6W	Short		
L01, L02 (L3)	-	3μH	enabled		
Stand-By Control Circuit	Tr1	2SC3332 (Reference)	$V_{CE} \geq 75V, I_C \geq 1mA$		
	D1 (*4)	GMB01 (Reference)	Di		
	R30	RN16S***FK	***kΩ, 1/6W	13kΩ	2.7kΩ
	R31	RN16S333FK	33kΩ, 1/6W		
	R32	RN16S102FK	1kΩ, 1/6W		
	R33	RN16S202FK	2kΩ, 1/6W		
	C32	10MV33HC	33μF, 10V		
J1, J2, J3, J4, J5, J6, J8, J9	-	-	enabled		
J7, JS2, JS3, JS4, JS5, JS7 JS8, JS9	-	-	-		
JS6, JS10	-	-	enabled		
JS1	ERG1SJ101	100Ω, 1W	enabled		

(*1) Capacitor mark "A" side is "-" (negative).

(*2) STK433-100Sr (2ch AMP) doesn't mount parts of ().

(*3) Add parts C23 to the other side of PCB.

(*4) Recommended standby circuit is used.

Evaluation Board Characteristics

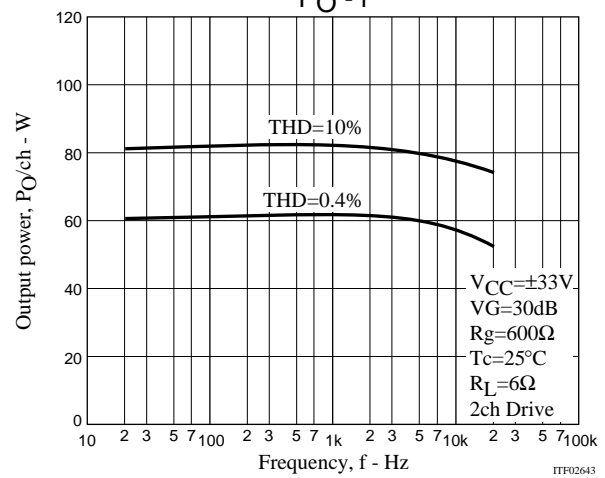
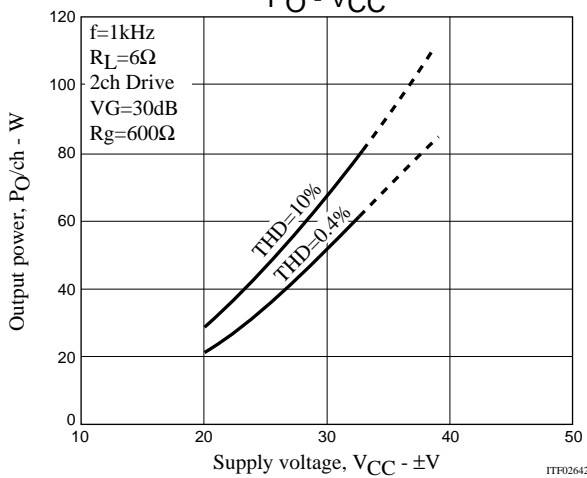
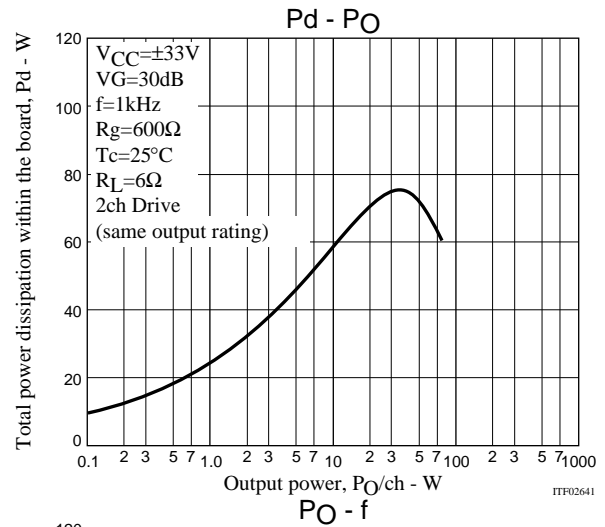
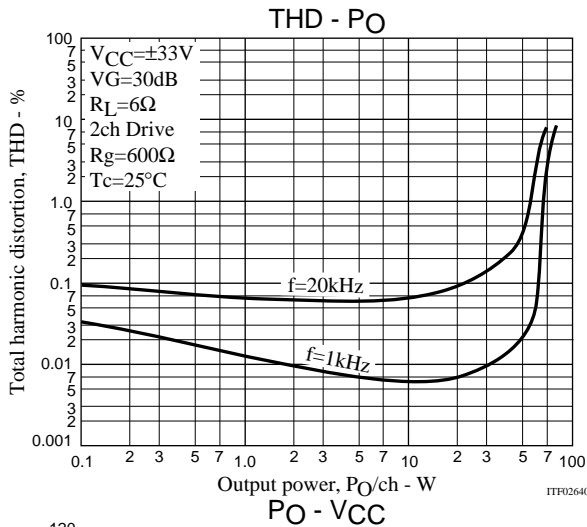

[Thermal Design Example for STK433-090-E (R_L = 6Ω)]

The thermal resistance, θ_{c-a}, of the heat sink for total power dissipation, Pd, within the hybrid IC is determined as follows.

Condition 1: The hybrid IC substrate temperature, T_c, must not exceed 125°C.

$$P_d \times \theta_{c-a} + T_a < 125^\circ\text{C} \dots\dots\dots (1)$$

T_a: Guaranteed ambient temperature for the end product

Condition 2: The junction temperature, T_j, of each power transistor must not exceed 150°C.

$$P_d \times \theta_{c-a} + P_d/N \times \theta_{j-c} + T_a < 150^\circ\text{C} \dots\dots\dots (2)$$

N: Number of power transistors

θ_{j-c}: Thermal resistance per power transistor

However, the power dissipation, Pd, for the power transistors shall be allocated equally among the number of power transistors.

The following inequalities result from solving equations (1) and (2) for θ_{c-a}.

$$\theta_{c-a} < (125 - T_a)/P_d \dots\dots\dots (1)'$$

$$\theta_{c-a} < (150 - T_a)/P_d - \theta_{j-c}/N \dots\dots\dots (2)'$$

Values that satisfy these two inequalities at the same time represent the required heat sink thermal resistance.

When the following specifications have been stipulated, the required heat sink thermal resistance can be determined from formulas (1)' and (2)'.

- Supply voltage V_{CC}
- Load resistance R_L
- Guaranteed ambient temperature T_a

STK433-090-E

[Example]

When the IC supply voltage, V_{CC} , is $\pm 33V$ and R_L is 6Ω , the total power dissipation, P_d , within the hybrid IC, will be a maximum of $75W$ at $1kHz$ for a continuous sine wave signal according to the P_d - P_O characteristics. For the music signals normally handled by audio amplifiers, a value of $1/8P_O$ max is generally used for P_d as an estimate of the power dissipation based on the type of continuous signal. (Note that the factor used may differ depending on the safety standard used.)

This is:

$$P_d \approx 59.0W \quad (\text{when } 1/8P_O \text{ max.} = 10W, P_O \text{ max.} = 80W).$$

The number of power transistors in audio amplifier block of these hybrid ICs, N , is 4, and the thermal resistance per transistor, θ_{j-c} , is $2.1^\circ C/W$. Therefore, the required heat sink thermal resistance for a guaranteed ambient temperature, T_a , of $50^\circ C$ will be as follows.

$$\text{From formula (1)'} \quad \theta_{c-a} < (125 - 50)/59.0 < 1.27$$

$$\text{From formula (2)'} \quad \theta_{c-a} < (150 - 50)/59.0 - 2.1/4 < 1.17$$

Therefore, the value of $1.17^\circ C/W$, which satisfies both of these formulae, is the required thermal resistance of the heat sink.

Note that this thermal design example assumes the use of a constant-voltage power supply, and is therefore not a verified design for any particular user's end product.

STK433-100 Series Standby Control, Mute Control, Load-short Protection & DC offset Protection application

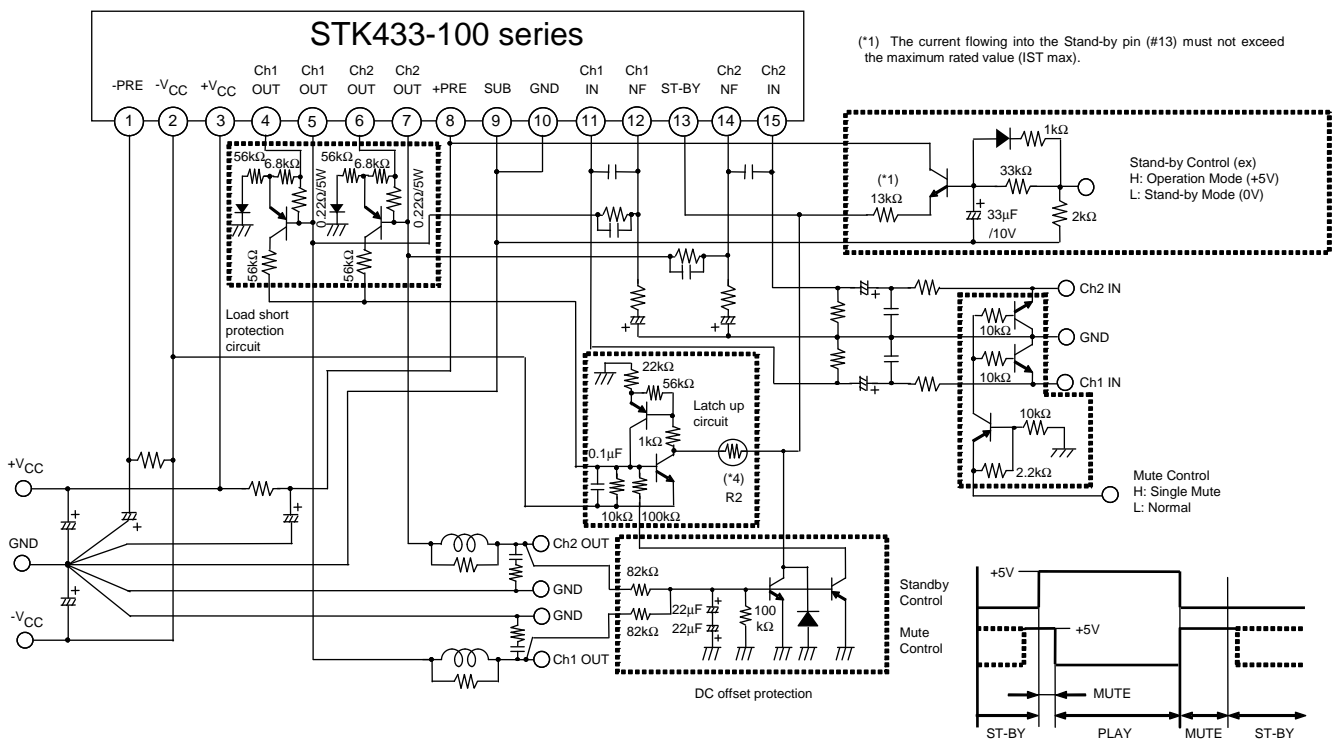

STK433-100 Series Application Explanation

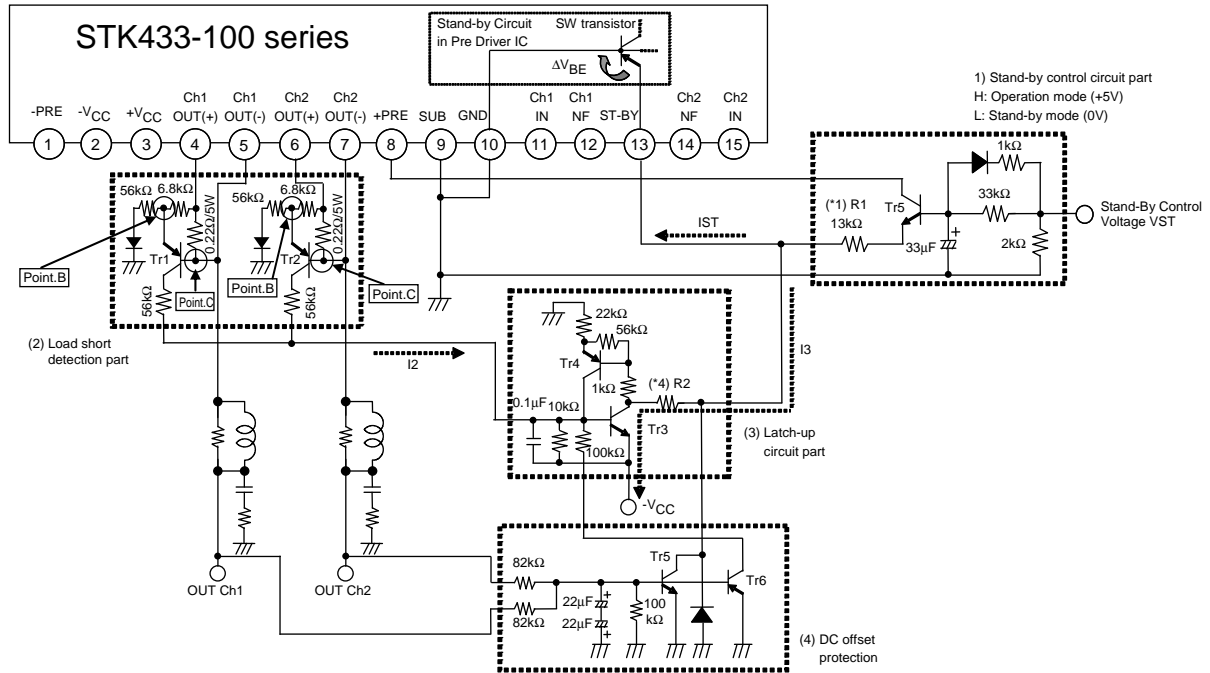

The protection circuit application for the STK433-100sr consists of the following blocks (blocks (1) to (4)).

- (1) Standby control circuit block
- (2) Load short-circuit detection block
- (3) Latch-up circuit block
- (4) DC voltage protection block

1) Standby control circuit block

(Reference example) STK433-100 series test circuit (when +5V is applied to Stand-by control.)

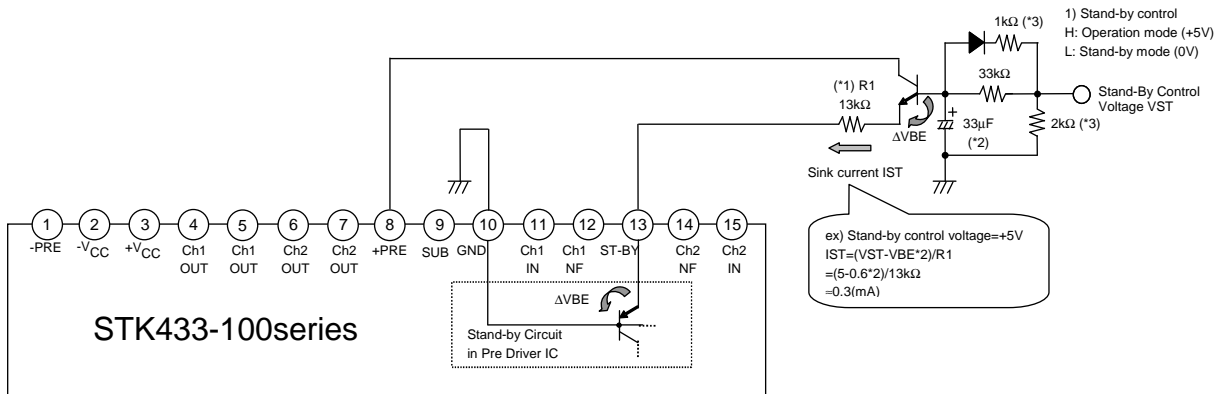

Concerning pin 13 reference voltage VST

<1> Operation mode

The switching transistor in the bias circuit turns on and places the amplifier into the operating mode when the current flowing into pin 13 (IST) becomes 0.25mA or greater.

<2> Standby mode

When the current flowing into pin 13 (IST) is stopped (=0mA), the switching transistor in the bias circuit turns off, placing the amplifier into the standby mode.

- (*1) The current limiting resistor (R1) must be used to ensure that the current flowing into the stand-by pin (pin 13) does not exceed its maximum rated value IST max.
- (*2) The pop noise level when the power is turned on can be reduced by setting the time constant with a capacitor in operating mode.
- (*3) Determines the time constant at which the capacitor (*2) is discharged in standby mode.

STK433-090-E

2) Load short-circuit detection block

Since the voltage between point B and point C is less than 0.6V in normal operation mode ($V_{BE} < 0.6V$) and TR1 (or TR2) is not activated, the load short-circuit detection block does not operate.

When a load short-circuit occurs, however, the voltage between point B and point C becomes larger than 0.6V, causing TR1 (or TR2) to turn on ($V_{BE} > 0.6V$), and current I2 to flows.

3) Latch-up circuit block

TR3 is activated when I2 is supplied to the latch-up circuit.

When TR3 turns on and current I3 starts flowing, VST goes down to 0V (standby mode), protecting the power amplifier.

Since TR3 and TR4 configure a thyristor, once TR3 is activated, the IC is held in the standby mode.

To release the standby mode and reactivate the power amplifier, it is necessary to set the standby control voltage temporarily low (0V). Subsequently, when the standby control is returned to high, the power amplifier will become active again.

(*4) The I3 value varies depending on the supply voltage. Determine the value of R2 using the formula below, so that

I1 is equal to or less than I3.

$$I1 \leq I3 = V_{CC}/R2$$

4) DC offset protection block

The DC offset protection circuit is activated when $\pm 0.5V$ (typ) voltage is applied to either "OUT CH1" or "OUT CH2," and the hybrid IC is shut down (standby mode).

To release the IC from the standby mode and reactivate the power amplifier, it is necessary to set the standby control voltage temporarily low (0V).

Subsequently, when the standby control is returned to high (+5V, for example), the power amplifier will become active again.

The protection level must be set using the 82k Ω resistor. Furthermore, the time constant must be determined using 22 μ /22 μ capacitors to prevent the amplifier from malfunctioning due to the audio signal.

STK433-100 Series BTL Application

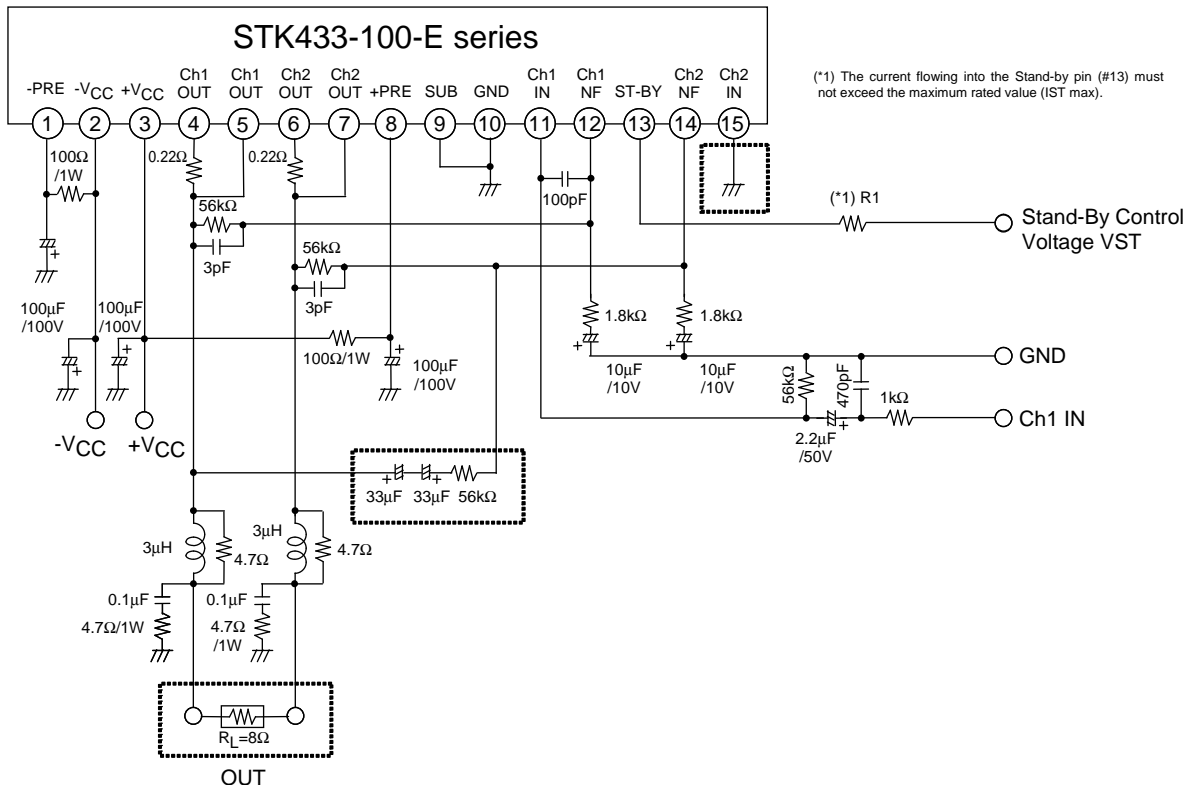

- SANYO Semiconductor Co.,Ltd. assumes no responsibility for equipment failures that result from using products at values that exceed, even momentarily, rated values (such as maximum ratings, operating condition ranges, or other parameters) listed in products specifications of any and all SANYO Semiconductor Co.,Ltd. products described or contained herein.
- SANYO Semiconductor Co.,Ltd. strives to supply high-quality high-reliability products, however, any and all semiconductor products fail or malfunction with some probability. It is possible that these probabilistic failures or malfunction could give rise to accidents or events that could endanger human lives, trouble that could give rise to smoke or fire, or accidents that could cause damage to other property. When designing equipment, adopt safety measures so that these kinds of accidents or events cannot occur. Such measures include but are not limited to protective circuits and error prevention circuits for safe design, redundant design, and structural design.
- In the event that any or all SANYO Semiconductor Co.,Ltd. products described or contained herein are controlled under any of applicable local export control laws and regulations, such products may require the export license from the authorities concerned in accordance with the above law.
- No part of this publication may be reproduced or transmitted in any form or by any means, electronic or mechanical, including photocopying and recording, or any information storage or retrieval system, or otherwise, without the prior written consent of SANYO Semiconductor Co.,Ltd.
- Any and all information described or contained herein are subject to change without notice due to product/technology improvement, etc. When designing equipment, refer to the "Delivery Specification" for the SANYO Semiconductor Co.,Ltd. product that you intend to use.
- Information (including circuit diagrams and circuit parameters) herein is for example only; it is not guaranteed for volume production.
- Upon using the technical information or products described herein, neither warranty nor license shall be granted with regard to intellectual property rights or any other rights of SANYO Semiconductor Co.,Ltd. or any third party. SANYO Semiconductor Co.,Ltd. shall not be liable for any claim or suits with regard to a third party's intellectual property rights which has resulted from the use of the technical information and products mentioned above.

This catalog provides information as of December, 2009. Specifications and information herein are subject to change without notice.