



**MOTOROLA**

## 8-BIT IDENTITY COMPARATOR

The MC54/74F521 is an expandable 8-bit comparator. It compares two words of up to eight bits each and provides a LOW output when the two words match bit for bit. The expansion input  $I_A = B$  also serves as an active-LOW enable input.

- Compares Two 8-Bit Words in 6.5 ns Typical
- Expandable to Any Word Length
- 20-Pin Package

**CONNECTION DIAGRAM (TOP VIEW)**

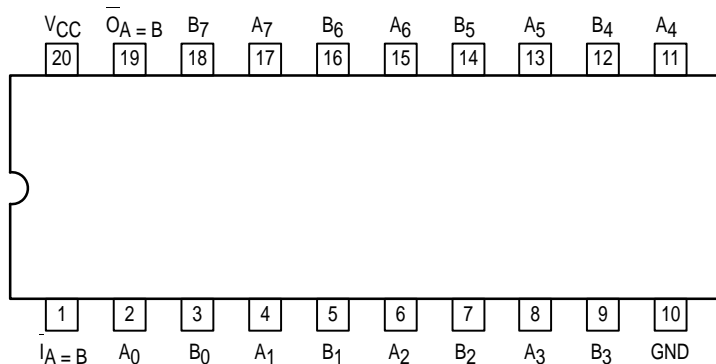

# MC54/74F521

**8-BIT IDENTITY COMPARATOR**  
**FAST™ SCHOTTKY TTL**

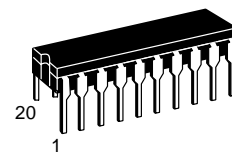

**J SUFFIX**  
CERAMIC  
CASE 732-03

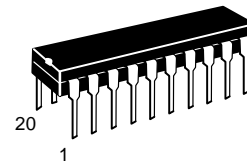

**N SUFFIX**  
PLASTIC  
CASE 738-03

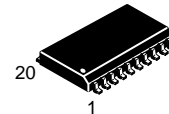

**DW SUFFIX**  
SOIC  
CASE 751D-03

### ORDERING INFORMATION

MC54FXXXJ	Ceramic
MC74FXXXN	Plastic
MC74FXXXDW	SOIC

### GUARANTEED OPERATING RANGES

Symbol	Parameter		Min	Typ	Max	Unit
$V_{CC}$	Supply Voltage	54, 74	4.5	5.0	5.5	V
$T_A$	Operating Ambient Temperature Range	54	-55	25	125	°C
		74	0	25	70	
$I_{OH}$	Output Current — High	54, 74			-1.0	mA
$I_{OL}$	Output Current — Low	54, 74			20	mA

LIFETIME BUY

LAST SHIP 30/09/99  
LAST ORDER 31/03/99

# MC54/74F521

**LOGIC DIAGRAM**

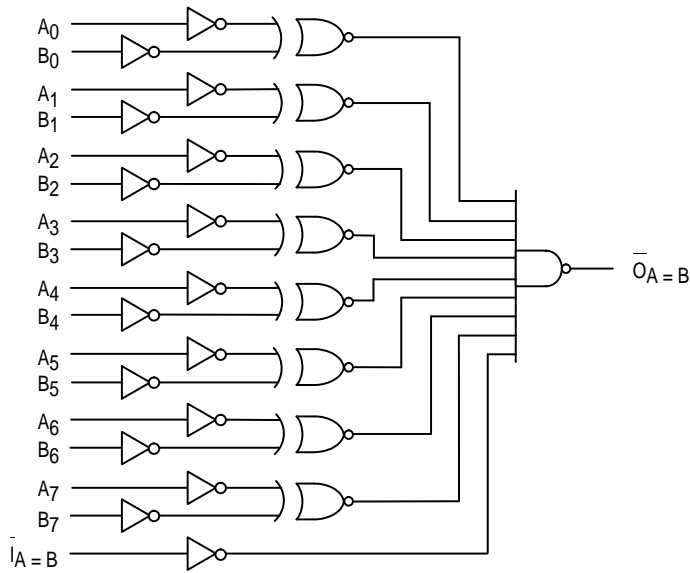

**LOGIC SYMBOL**

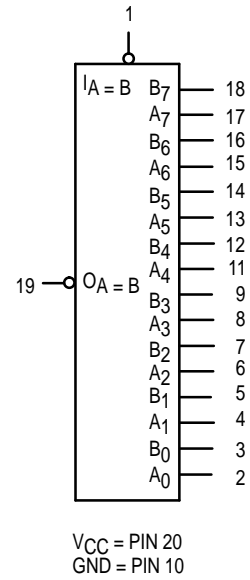

NOTE:  
This diagram is provided only for the understanding of logic operations and should not be used to estimate propagation delays.

**DC CHARACTERISTICS OVER OPERATING TEMPERATURE RANGE** (unless otherwise specified)

Symbol	PARAMETER	Limits			Unit	Test Conditions	
		Min	Typ	Max			
$V_{IH}$	Input HIGH Voltage	2.0			V	Guaranteed Input HIGH Voltage	
$V_{IL}$	Input LOW Voltage			0.8	V	Guaranteed Input LOW Voltage	
$V_{IK}$	Input Clamp Diode Voltage			-1.2	V	$I_{IN} = -18 \text{ mA}$	$V_{CC} = \text{MIN}$
$V_{OH}$	Output HIGH Voltage	54, 74	2.5	3.4	V	$I_{OH} = -1.0 \text{ mA}$	$V_{CC} = 4.5 \text{ V}$
		74	2.7	3.4	V	$I_{OH} = -1.0 \text{ mA}$	$V_{CC} = 4.75 \text{ V}$
$V_{OL}$	Output LOW Voltage		0.35	0.5	V	$I_{OL} = 20 \text{ mA}$	$V_{CC} = \text{MIN}$
$I_{IH}$	Input HIGH Current			20	$\mu\text{A}$	$V_{IN} = 2.7 \text{ V}$	$V_{CC} = \text{MAX}$
				100	$\mu\text{A}$	$V_{IN} = 7.0 \text{ V}$	
$I_{IL}$	Input LOW Current			-0.6	mA	$V_{IN} = 0.5 \text{ V}$	$V_{CC} = \text{MAX}$
$I_{OS}$	Output Short Circuit Current (Note 2)	-60		-150	mA	$V_{OUT} = 0 \text{ V}$	$V_{CC} = \text{MAX}$
$I_{CC}$	Power Supply Current		21	32	mA	$I_A = B = \text{GND}$	$V_{CC} = \text{MAX}$

NOTES:  
1. For conditions shown as MIN or MAX, use the appropriate value specified under guaranteed operating ranges.  
2. Not more than one output should be shorted at a time, nor for more than 1 second.

LIFETIME BUY

LAST SHIP 30/09/99  
LAST ORDER 31/03/99

# MC54/74F521

## FUNCTION TABLE

Inputs		Output
$I_A = B$	A, B	$O_A = B$
L	$A = B^*$	L
L	$A \neq B$	H
H	$A = B^*$	H
H	$A \neq B$	H

H = HIGH Voltage Level  
 L = LOW Voltage Level  
 \* $A_0 = B_0, A_1 = B_1, A_2 = B_2$ , etc.

## AC CHARACTERISTICS

Symbol	Parameter	54/74F			54F		74F		Unit
		$T_A = +25^\circ\text{C}$ $V_{CC} = +5.0\text{ V}$ $C_L = 50\text{ pF}$			$T_A = -55^\circ\text{C to } +125^\circ\text{C}$ $V_{CC} = 5.0\text{ V} \pm 10\%$ $C_L = 50\text{ pF}$		$T_A = 0^\circ\text{C to } +70^\circ\text{C}$ $V_{CC} = 5.0\text{ V} \pm 10\%$ $C_L = 50\text{ pF}$		
		Min	Typ	Max	Min	Max	Min	Max	
$t_{PLH}$	Propagation Delay $\bar{O}_A = B$	2.5	6.5	10	2.5	15	2.5	11	ns
$t_{PHL}$	$A_n$ or $B_n$ to $\bar{O}_A = B$	3.0	6.5	10	3.0	12	3.0	11	
$t_{PLH}$	Propagation Delay $\bar{I}_A = B$ to $\bar{O}_A = B$	2.5	4.5	6.5	2.5	8.5	2.5	7.5	ns
$t_{PHL}$	$\bar{I}_A = B$ to $\bar{O}_A = B$	3.5	5.0	9.0	3.5	10	3.5	10	

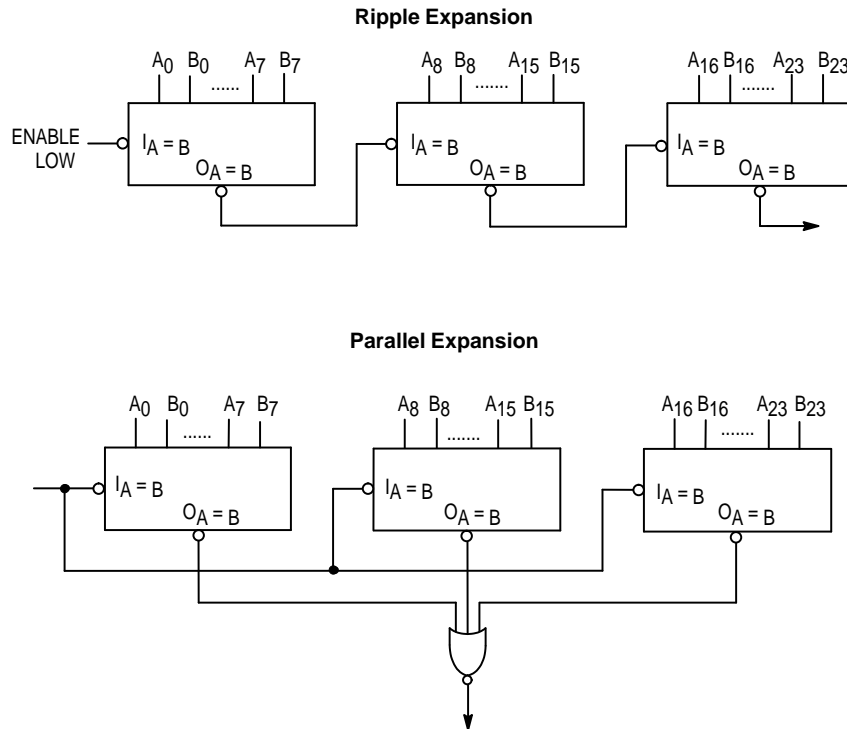

Figure 1. Applications

LIFETIME BUY

LAST SHIP 30/09/99  
 LAST ORDER 31/03/99

LIFETIME BUY

LAST ORDER 31/03/99 LAST SHIP 30/09/99

Mfax is a trademark of Motorola, Inc.

Motorola reserves the right to make changes without further notice to any products herein. Motorola makes no warranty, representation or guarantee regarding the suitability of its products for any particular purpose, nor does Motorola assume any liability arising out of the application or use of any product or circuit, and specifically disclaims any and all liability, including without limitation consequential or incidental damages. "Typical" parameters which may be provided in Motorola data sheets and/or specifications can and do vary in different applications and actual performance may vary over time. All operating parameters, including "Typicals" must be validated for each customer application by customer's technical experts. Motorola does not convey any license under its patent rights nor the rights of others. Motorola products are not designed, intended, or authorized for use as components in systems intended for surgical implant into the body, or other applications intended to support or sustain life, or for any other application in which the failure of the Motorola product could create a situation where personal injury or death may occur. Should Buyer purchase or use Motorola products for any such unintended or unauthorized application, Buyer shall indemnify and hold Motorola and its officers, employees, subsidiaries, affiliates, and distributors harmless against all claims, costs, damages, and expenses, and reasonable attorney fees arising out of, directly or indirectly, any claim of personal injury or death associated with such unintended or unauthorized use, even if such claim alleges that Motorola was negligent regarding the design or manufacture of the part. Motorola and  are registered trademarks of Motorola, Inc. Motorola, Inc. is an Equal Opportunity/Affirmative Action Employer.

**How to reach us:**

**USA/EUROPE/Locations Not Listed:** Motorola Literature Distribution; P.O. Box 5405, Denver, Colorado 80217.  
1-303-675-2140 or 1-800-441-2447

**JAPAN:** Motorola Japan Ltd.; SPS, Technical Information Center, 3-20-1, Minami-Azabu. Minato-ku, Tokyo 106-8573 Japan.  
81-3-3440-3569

**ASIA/PACIFIC:** Motorola Semiconductors H.K. Ltd.; Silicon Harbour Centre, 2 Dai King Street, Tai Po Industrial Estate, Tai Po, N.T., Hong Kong. 852-26668334

**Customer Focus Center: 1-800-521-6274**

**Mfax™:** RMFAX0@email.sps.mot.com – TOUCHTONE 1-602-244-6609  
Motorola Fax Back System – US & Canada ONLY 1-800-774-1848  
– <http://sps.motorola.com/mfax/>

**HOME PAGE:** <http://motorola.com/sps/>



**MOTOROLA**

