

Description

The ZXGD3002E6 is a high-speed, non-inverting single gate driver designed for switching MOSFETs or IGBTs. It can transfer up to 5A peak source/source current into the gate for effective charging and discharging of the capacitive gate load.

This gate driver ensures rapid switching of the MOSFET to minimize power losses and distortion in high current switching applications. It can typically drive 2A into the low gate impedance with just 10mA input from a controller. The turn-on and turn-off switching behaviour of the MOSFET can be individually tailored to suit an application. By defining the switching characteristics appropriately, EMI and cross conduction can be reduced.

Applications

Gate Driving Power MOSFETs in:

- AC-DC Power Supplies (SMPS)
- DC-DC Converters
- DC-AC Inverters (i.e. Solar)
- 1-, 2-, and 3-Phase Motor Control Circuits
- Amplifier Output Stages

Features

- High-Gain Buffer with Typically 2A Output from 10mA Input
- 9A Peak Output Current
- Emitter-Follower that is Rugged to Latch-Up/Shoot-Through
- Fast Switching Emitter-Follower Configuration:
- 2ns Propagation Delay Time
- 9ns Rise/Fall Time, 1000pF Load
- Optimized Pinout to Simplify PCB Layout and Reduce Parasitic Trace Inductances
- Near-Zero Quiescent Supply Current
- **Totally Lead-Free & Fully RoHS Compliant (Notes 1 & 2)**
- **Halogen and Antimony Free. "Green" Device (Note 3)**
- **For automotive applications requiring specific change control (i.e. parts qualified to AEC-Q100/101/200, PPAP capable, and manufactured in IATF 16949 certified facilities), please [contact us](#) or your local Diodes representative.**
<https://www.diodes.com/quality/product-definitions/>

Mechanical Data

- Case: SOT26
- Case Material: Molded Plastic. "Green" Molding Compound. UL Flammability Rating 94V-0
- Moisture Sensitivity: Level 1 per J-STD-020
- Terminals: Finish – Matte Tin Plated Leads. Solderable per MIL-STD-202, Method 208 @3
- Weight: 0.018 grams (Approximate)

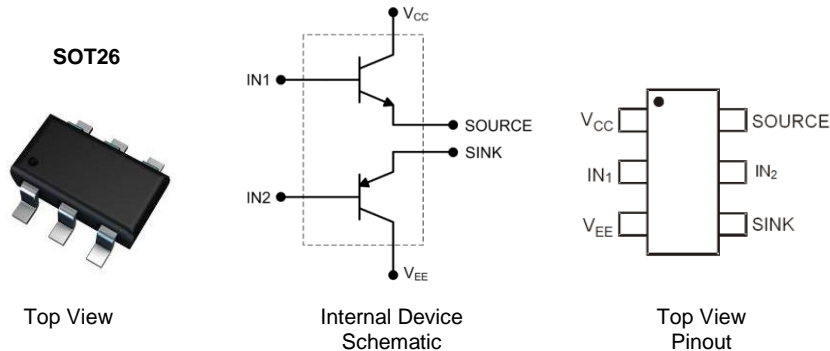

Pin Name	Pin Function
V _{CC}	Supply Voltage High
IN ₁ & IN ₂	Driver Input*
V _{EE}	Supply Voltage Low
SOURCE	Source Current Output**
SINK	Sink Current Output**

* Typically connect IN₁ & IN₂ together
 ** Typically connect SOURCE & SINK together

Ordering Information (Note 4)

Part Number	Compliance	Marking	Reel Size (inches)	Tape Width (mm)	Quantity per Reel
ZXGD3002E6TA	Standard	3002	7	8	3000

- Notes:
1. No purposely added lead. Fully EU Directive 2002/95/EC (RoHS), 2011/65/EU (RoHS 2) & 2015/863/EU (RoHS 3) compliant.
 2. See <https://www.diodes.com/quality/lead-free/> for more information about Diodes Incorporated's definitions of Halogen- and Antimony-free, "Green" and Lead-free.
 3. Halogen- and Antimony-free "Green" products are defined as those which contain <900ppm bromine, <900ppm chlorine (<1500ppm total Br + Cl) and <1000ppm antimony compounds.
 4. For packaging details, go to our website at <https://www.diodes.com/design/support/packaging/diodes-packaging/>.

Marking Information

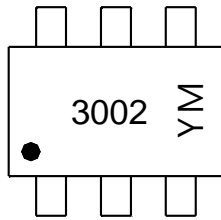

3002 = Product Type Marking Code
 YM = Date Code Marking
 Y or \bar{Y} = Year (ex: I = 2021)
 M or \bar{M} = Month (ex: 9 = September)

Date Code Key

Year	2010	...	2021	2022	2023	2024	2025	2026	2027	2028	2029	2030
Code	X	...	I	J	K	L	M	N	O	P	R	S

Month	Jan	Feb	Mar	Apr	May	Jun	Jul	Aug	Sep	Oct	Nov	Dec
Code	1	2	3	4	5	6	7	8	9	O	N	D

Typical Application Circuit

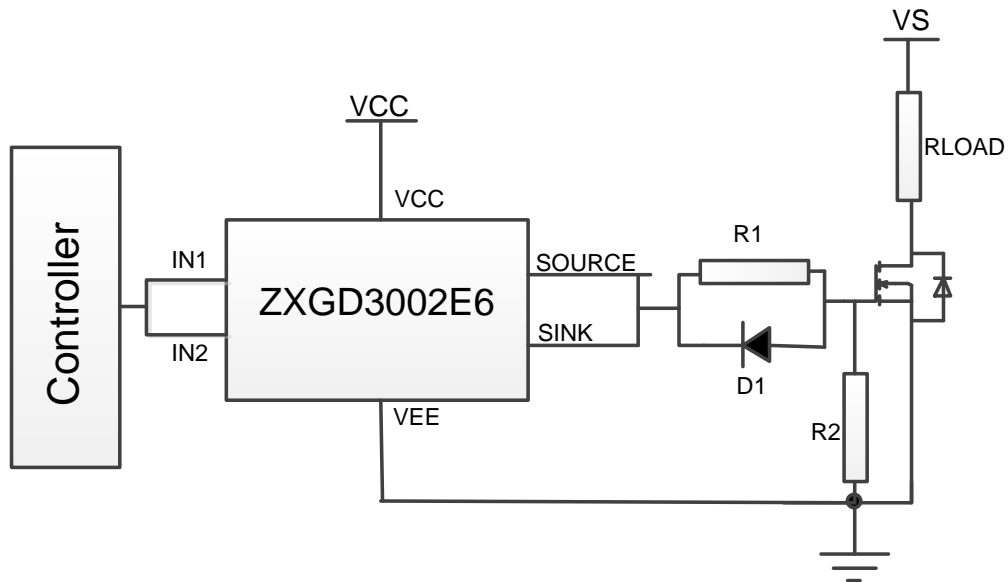

R1, D1 combination can be used for variable turn on and turn off times.

Absolute Maximum Ratings (@T_A = +25°C, unless otherwise specified.)

Characteristic	Symbol	Value	Unit
Supply Voltage	V _{CC}	20	V
Input Voltage	V _{IN}	20	V
Output Difference Voltage (Source – Sink)	ΔV _(source-sink)	±7	V
Peak Pulsed Output Current (Source & Sink)	I _{OM}	±9	A
Peak Pulsed Input current	I _{IN1} , I _{IN2}	±1	A

Thermal Characteristics

Characteristic	Symbol	Value	Unit
Power Dissipation (Notes 5 & 6)	P _D	1.1	W
Linear Derating Factor		8.8	mW/°C
Thermal Resistance, Junction to Ambient (Notes 5 & 6)	R _{θJA}	113	°C/W
Thermal Resistance, Junction to Lead (Note 7)	R _{θJL}	105	°C/W
Operating and Storage Temperature Range	T _J , T _{STG}	-55 to +150	°C

ESD Ratings (Note 8)

Characteristic	Symbol	Value	Unit	JEDEC Class
Electrostatic Discharge - Human Body Model	ESD HBM	4000	V	3A
Electrostatic Discharge - Machine Model	ESD MM	400	V	C
Electrostatic Discharge – Charged Device Model	ESD CDM	1000	V	IV

- Notes:
5. For a device mounted on 25mm × 25mm 1oz copper that is on a single-sided 1.6mm FR4 PCB; device is measured under still air conditions while operating in a steady-state. The heatsink is split in half with the pin 1 (V_{CC}) and pin 3 (V_{EE}) connected separately to each half.
 6. For device with two active die running at equal power.
 7. Thermal resistance from junction to solder-point at the end of each lead on pin 1 (V_{CC}) and pin 3 (V_{EE}).
 8. Refer to JEDEC specification JESD22-A114, JESD22-A115, and JESD22-C101.

Electrical Characteristics (@T_A = +25°C, unless otherwise specified.)

Parameter	Symbol	Min.	Typ.	Max.	Unit	Conditions
Output Voltage, High	V _{OUT(hi)}	—	V _{CC} - 0.4	—	V	I _{SOURCE} = 1μA
Output Voltage, Low	V _{OUT(low)}	—	V _{EE} + 0.4	—	V	I _{SINK} = 1μA
Source Output Leakage Current	I _{L(SOURCE)}	—	—	1	μA	V _{CC} = 20V, V _{IN1} = V _{IN2} = 0V
Sink Output Leakage Current	I _{L(SINK)}	—	—	1	μA	V _{CC} = 20V, V _{IN1} = V _{IN2} = V _{CC}
Quiescent Current	I _Q	—	—	50	nA	V _{CC} = 16V, V _{IN1} = V _{IN2} = 0V
Peak Pulsed Source Output Current	I _{(SOURCE)M}	1.6	2.2	—	A	I _{IN1} + I _{IN2} = 10mA
Peak Pulsed Sink Output Current	I _{(SINK)M}	1.4	2	—	A	I _{IN1} + I _{IN2} = -10mA
Peak Pulsed Source Output Current	I _{(SOURCE)M}	—	9	—	A	I _{IN1} + I _{IN2} = 1A
Peak Pulsed Sink Output Current	I _{(SINK)M}	—	9	—	A	I _{IN1} + I _{IN2} = -1A
Gate Driver Switching Times	t _{D(RISE)}	—	1.25	—	ns	V _{CC} = 12V, V _{EE} = 0V, V _{IN} = 0 to 10V, C _L = 1nF, R _L = 1Ω, R _{IN} = 25Ω
	t _r	—	8.3	—		
	t _{D(FALL)}	—	1.6	—		
	t _f	—	10.8	—		
Gate Driver Switching Times	t _{D(RISE)}	—	3.6	—	ns	V _{CC} = 12V, V _{EE} = 0V, V _{IN} = 0 to 10V, C _L = 1nF, R _L = 1Ω, R _{IN} = 1kΩ
	t _r	—	105	—		
	t _{D(FALL)}	—	6.9	—		
	t _f	—	115	—		

Switching Test Circuit and Timing Diagram

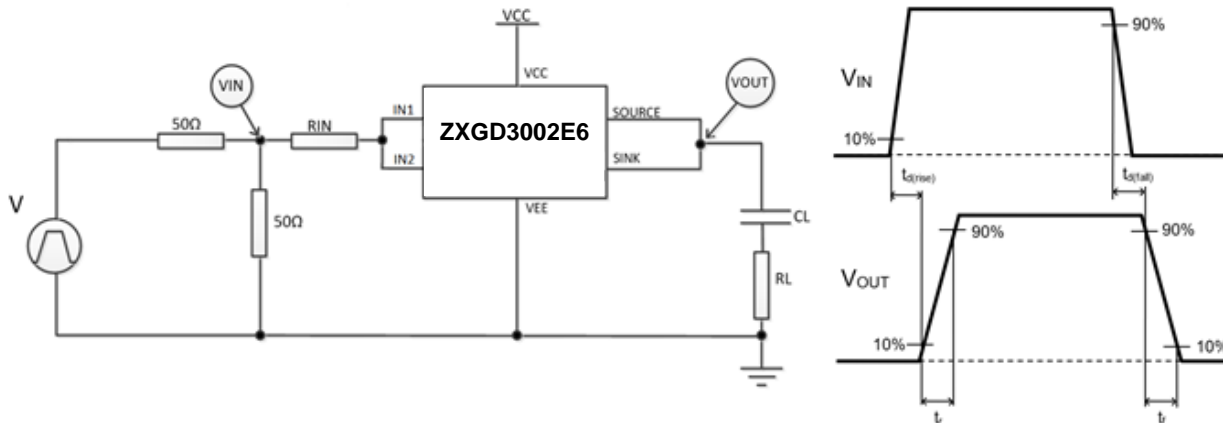

Typical Switching Characteristics (@ $T_A = +25^\circ\text{C}$, unless otherwise specified.)

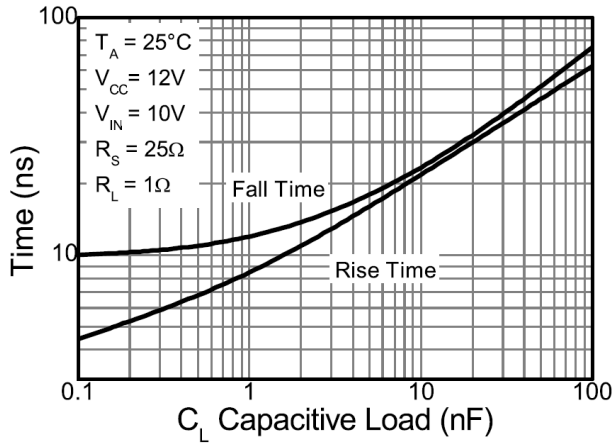

Rise and Fall Time

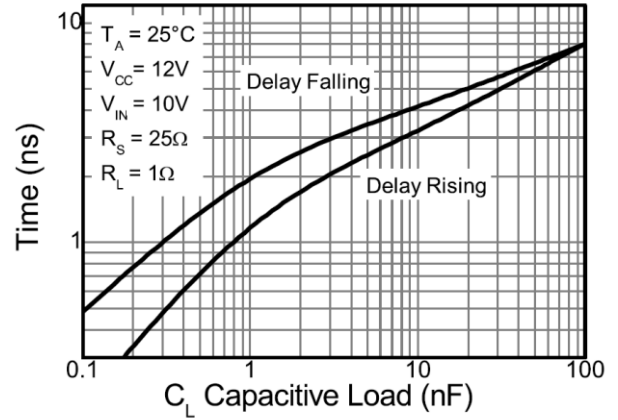

Propagation Delay

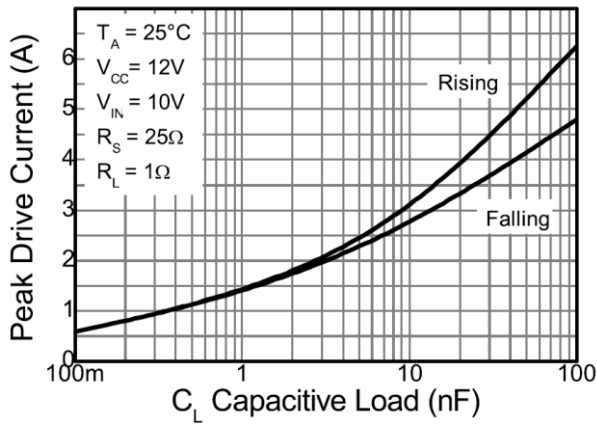

Peak Drive Current

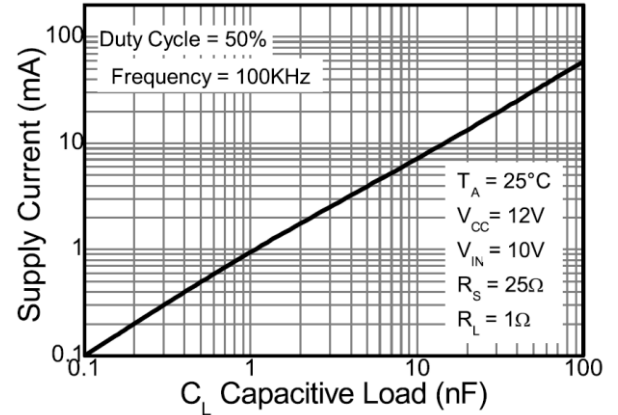

Supply Current

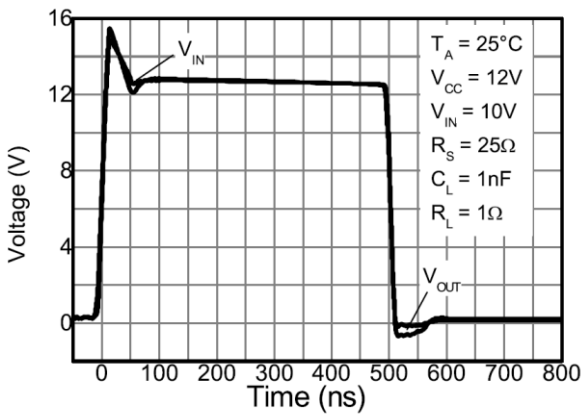

Switching Speed

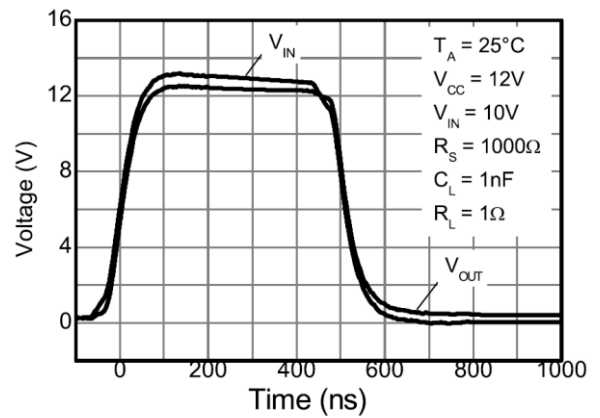

Switching Speed

Typical Switching Characteristics (Continued) (@T_A = +25°C, unless otherwise specified.)

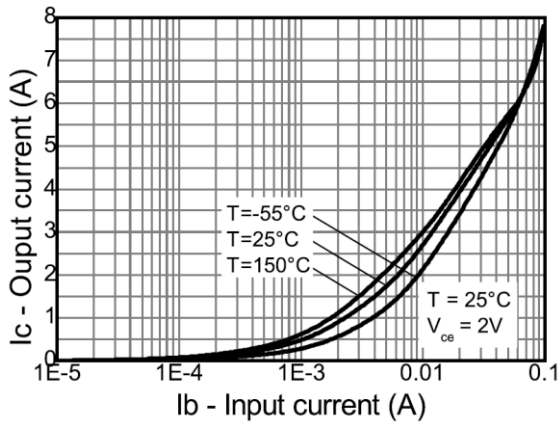

Source Current Vs Input Current

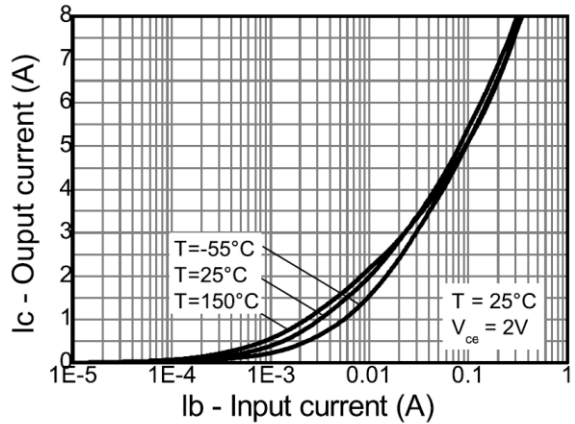

Sink Current Vs Input Current

Package Outline Dimensions

Please see <http://www.diodes.com/package-outlines.html> for the latest version.

SOT26

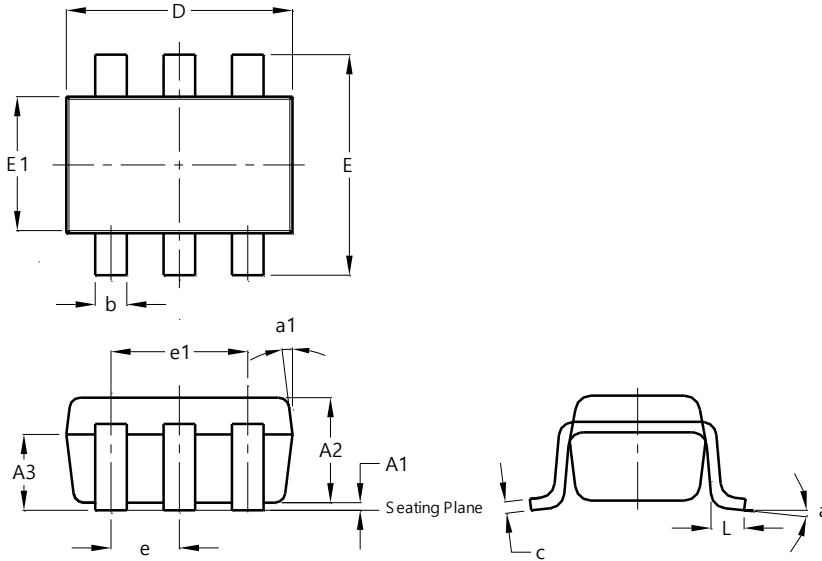

SOT26			
Dim	Min	Max	Typ
A1	0.013	0.10	0.05
A2	1.00	1.30	1.10
A3	0.70	0.80	0.75
b	0.35	0.50	0.38
c	0.10	0.20	0.15
D	2.90	3.10	3.00
e	-	-	0.95
e1	-	-	1.90
E	2.70	3.00	2.80
E1	1.50	1.70	1.60
L	0.35	0.55	0.40
a	-	-	8°
a1	-	-	7°
All Dimensions in mm			

Suggested Pad Layout

Please see <http://www.diodes.com/package-outlines.html> for the latest version.

SOT26

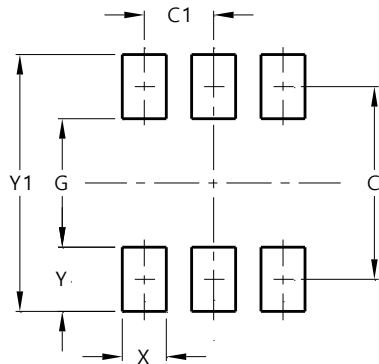

Dimensions	Value (in mm)
C	2.40
C1	0.95
G	1.60
X	0.55
Y	0.80
Y1	3.20

IMPORTANT NOTICE

1. DIODES INCORPORATED AND ITS SUBSIDIARIES ("DIODES") MAKE NO WARRANTY OF ANY KIND, EXPRESS OR IMPLIED, WITH REGARDS TO ANY INFORMATION CONTAINED IN THIS DOCUMENT, INCLUDING, BUT NOT LIMITED TO, THE IMPLIED WARRANTIES OF MERCHANTABILITY, FITNESS FOR A PARTICULAR PURPOSE OR NON-INFRINGEMENT OF THIRD PARTY INTELLECTUAL PROPERTY RIGHTS (AND THEIR EQUIVALENTS UNDER THE LAWS OF ANY JURISDICTION).
2. The Information contained herein is for informational purpose only and is provided only to illustrate the operation of Diodes products described herein and application examples. Diodes does not assume any liability arising out of the application or use of this document or any product described herein. This document is intended for skilled and technically trained engineering customers and users who design with Diodes products. Diodes products may be used to facilitate safety-related applications; however, in all instances customers and users are responsible for (a) selecting the appropriate Diodes products for their applications, (b) evaluating the suitability of the Diodes products for their intended applications, (c) ensuring their applications, which incorporate Diodes products, comply the applicable legal and regulatory requirements as well as safety and functional-safety related standards, and (d) ensuring they design with appropriate safeguards (including testing, validation, quality control techniques, redundancy, malfunction prevention, and appropriate treatment for aging degradation) to minimize the risks associated with their applications.
3. Diodes assumes no liability for any application-related information, support, assistance or feedback that may be provided by Diodes from time to time. Any customer or user of this document or products described herein will assume all risks and liabilities associated with such use, and will hold Diodes and all companies whose products are represented herein or on Diodes' websites, harmless against all damages and liabilities.
4. Products described herein may be covered by one or more United States, international or foreign patents and pending patent applications. Product names and markings noted herein may also be covered by one or more United States, international or foreign trademarks and trademark applications. Diodes does not convey any license under any of its intellectual property rights or the rights of any third parties (including third parties whose products and services may be described in this document or on Diodes' website) under this document.
5. Diodes products are provided subject to Diodes' Standard Terms and Conditions of Sale (<https://www.diodes.com/about/company/terms-and-conditions/terms-and-conditions-of-sales/>) or other applicable terms. This document does not alter or expand the applicable warranties provided by Diodes. Diodes does not warrant or accept any liability whatsoever in respect of any products purchased through unauthorized sales channel.
6. Diodes products and technology may not be used for or incorporated into any products or systems whose manufacture, use or sale is prohibited under any applicable laws and regulations. Should customers or users use Diodes products in contravention of any applicable laws or regulations, or for any unintended or unauthorized application, customers and users will (a) be solely responsible for any damages, losses or penalties arising in connection therewith or as a result thereof, and (b) indemnify and hold Diodes and its representatives and agents harmless against any and all claims, damages, expenses, and attorney fees arising out of, directly or indirectly, any claim relating to any noncompliance with the applicable laws and regulations, as well as any unintended or unauthorized application.
7. While efforts have been made to ensure the information contained in this document is accurate, complete and current, it may contain technical inaccuracies, omissions and typographical errors. Diodes does not warrant that information contained in this document is error-free and Diodes is under no obligation to update or otherwise correct this information. Notwithstanding the foregoing, Diodes reserves the right to make modifications, enhancements, improvements, corrections or other changes without further notice to this document and any product described herein. This document is written in English but may be translated into multiple languages for reference. Only the English version of this document is the final and determinative format released by Diodes.
8. Any unauthorized copying, modification, distribution, transmission, display or other use of this document (or any portion hereof) is prohibited. Diodes assumes no responsibility for any losses incurred by the customers or users or any third parties arising from any such unauthorized use.

Copyright © 2021 Diodes Incorporated

www.diodes.com