

+3.3V Low Power Quad RS-485/RS-422 Line Receivers

- RS-485 or RS-422 Quad Differential Line Receivers
- Operates from a single +3.3V supply
- Interoperable with +5.0V logic
- Tri-state Output Control
- -7V to +12V Common-Mode Input Voltage Range
- Common Driver Enable Control (**SP3488**)
- Independent Driver Enable Controls for each pair of Drivers (**SP3489**)
- Compatibility with LTC488 and SN75173 (**SP3488**)
- Compatibility with LTC489 and SN75175 (**SP3489**)



Now Available in Lead Free Packaging

DESCRIPTION...

The **SP3488** and the **SP3489** are +3.3V low power quad line receivers that meet the specifications of the RS-485 and RS-422 serial protocols. These devices are pin-to-pin compatible with Sipex's SP488 and SP489 devices as well as popular industry standards. The **SP3488** and **SP3489** feature Sipex's BiCMOS process allowing low power operation without sacrificing performance. The **SP3488** and **SP3489** meet the electrical specifications of RS-485 and RS-422 serial protocols up to 10Mbps under load. The **SP3488** features a common receiver enable control. The **SP3489** provides independent receiver enable controls for each pair of receivers. Both devices feature tri-state outputs and a -7V to +12V common-mode input range. The receivers have a fail-safe feature which forces a logic "1" output when receiver inputs are left floating.

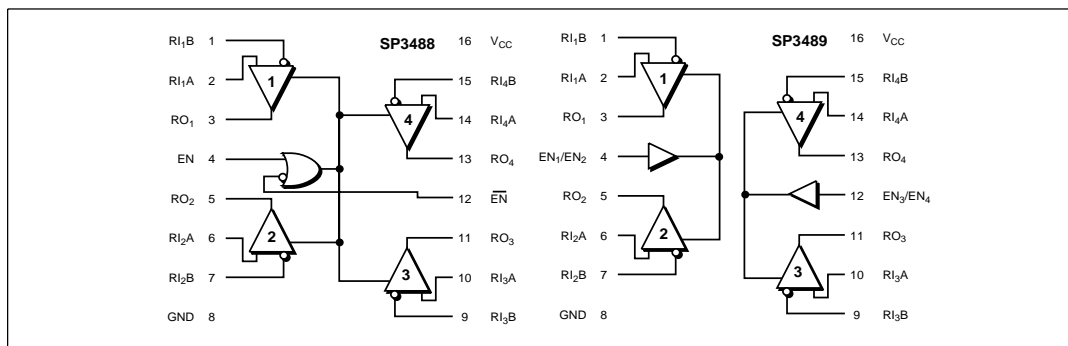

ABSOLUTE MAXIMUM RATINGS

These are stress ratings only and functional operation of the device at these or any other above those indicated in the operation sections of the specifications below is not implied. Exposure to absolute maximum rating conditions for extended periods of time may affect reliability.

V _{CC}	+6.0V
Input Voltages	
Logic	-0.3V to +6.0V
Receiver	±14V
Receiver Output Voltage	-0.3V to +6.0V
Input Currents	
Logic	±25mA
Storage Temperature	-65°C to +150°C
Power Dissipation	
Plastic DIP	375mW
(derate 7mW/°C above +70°C)	
Small Outline	375mW
(derate 7mW/°C above +70°C)	
Lead Temperature (soldering, 10 sec)	300°C



CAUTION:
ESD (ElectroStatic Discharge) sensitive device. Permanent damage may occur on unconnected devices subject to high energy electrostatic fields. Unused devices must be stored in conductive foam or shunts. Personnel should be properly grounded prior to handling this device. The protective foam should be discharged to the destination socket before devices are removed.

SPECIFICATIONS

V_{CC} = +3.3V±5%; typicals at 25°C; T_{MIN} ≤ T_A ≤ T_{MAX} unless otherwise noted.

PARAMETER	MIN.	TYP.	MAX.	UNIT	CONDITIONS
DC CHARACTERISTICS					
Digital Inputs					EN, $\overline{\text{EN}}$, EN ₁ /EN ₂ , EN ₃ /EN ₄
Voltage			0.8	Volts	
V _{IL}	2.0			Volts	
V _{IH}			±2	μA	0V ≤ V _{IN} ≤ V _{CC}
Input Current					
RECEIVER INPUTS					
Input Resistance	12			kΩ	-7V ≤ V _{CM} ≤ 12V
Differential Input Threshold	-0.2		+0.2	Volts	-7V ≤ V _{CM} ≤ 12V
Input Current (A, B)			+1.0	mA	V _{CC} = 0V or 3.3V; I _{IN2}
			-0.8	mA	V _{IN} = +12V
Maximum Data Rate	10			Mbps	V _{IN} = -7V
RECEIVER OUTPUTS					
Output Voltage				V	I _O = -1.5mA; V _{ID} = +0.2V
V _{OH}	V _{CC} -0.4		0.4	V	I _O = +2.5mA; V _{ID} = -0.2V
V _{OL}			±1	μA	V _{CC} = maximum; 0.4V ≤ V _O ≤ V _{CC}
High Impedance Output Current					
POWER REQUIREMENTS					
Supply Current		2.2	5	mA	No load
ENVIRONMENTAL AND MECHANICAL					
Operating Temperature				°C	
-C	0		+70	°C	
-E	-40		+85	°C	
Storage Temperature	-65		+150	°C	
Package					
-P	16-pin Plastic DIP				
-T	16-pin SOIC				

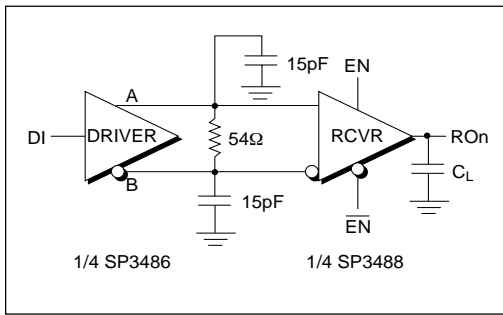

Figure 1. Timing Test Circuit

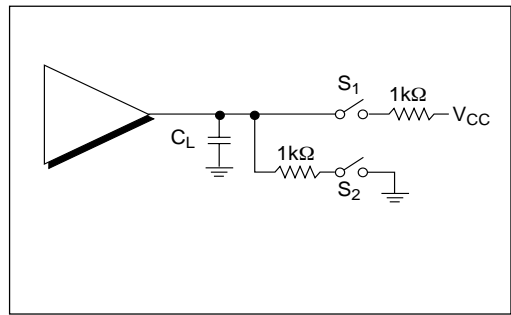

Figure 2. Enable/Disable Timing Test Circuit

SP3488 PINOUT

Pin 1 — RI_1B — Receiver 1 input B.

Pin 2 — RI_1A — Receiver 1 input A.

Pin 3 — RO_1 — Receiver 1 Output — If Receiver 1 output is enabled, if $RI_1A > RI_1B$ by 200mV, Receiver output is high. If Receiver 1 output is enabled, and if $RI_1A < RI_1B$ by 200mV, Receiver 1 output is low.

Pin 4 — EN — Receiver Output Enable. Please refer to SP3488 Truth Table (1).

Pin 5 — RO_2 — Receiver 2 Output — If Receiver 2 output is enabled, if $RI_2A > RI_2B$ by 200mV, Receiver 2 output is high. If Receiver 2 output is enabled, and if $RI_2A < RI_2B$ by 200mV, Receiver 2 output is low.

Pin 6 — RI_2A — Receiver 2 input A.

Pin 7 — RI_2B — Receiver 2 input B.

Pin 8 — GND — Digital Ground.

Pin 9 — RI_3B — Receiver 3 input B.

Pin 10 — RI_3A — Receiver 3 input A.

Pin 11 — RO_3 — Receiver 3 Output — If Receiver 3 output is enabled, if $RI_3A > RI_3B$ by 200mV, Receiver 3 output is high. If Receiver 3 output is enabled, and if $RI_3A < RI_3B$ by 200mV, Receiver 3 output is low.

Pin 12 — \overline{EN} — Receiver Output Enable. Please refer to SP3488 Truth Table (1).

PINOUT

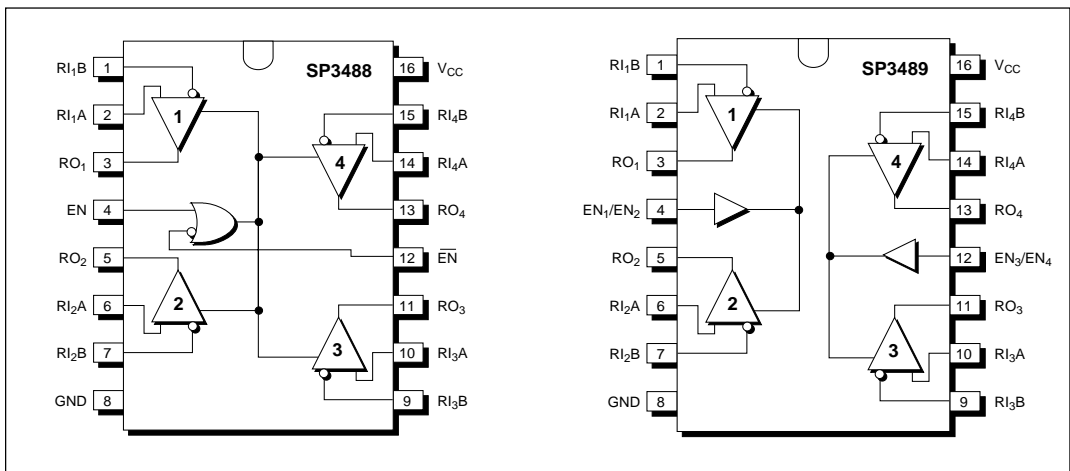

Pin 13 — RO₄ — Receiver 4 Output — If Receiver 4 output is enabled, if RI_{4A} > RI_{4B} by 200mV, Receiver 4 output is high. If Receiver 4 output is enabled, and if RI_{4A} < RI_{4B} by 200mV, Receiver 4 output is low.

Pin 14 — RI_{4A} — Receiver 4 input A.

Pin 15 — RI_{4B} — Receiver 4 input B.

Pin 16 — V_{cc} — Positive Supply +3.00V < V_{cc} < +3.60V

SP3489 PINOUT

Pin 1 — RI_{1B} — Receiver 1 input B.

Pin 2 — RI_{1A} — Receiver 1 input A.

Pin 3 — RO₁ — Receiver 1 Output — If Receiver 1 output is enabled, if RI_{1A} > RI_{1B} by 200mV, Receiver output is high. If Receiver 1 output is enabled, and if RI_{1A} < RI_{1B} by 200mV, Receiver 1 output is low.

Pin 4 — EN1/EN2 — Receiver 1 and 2 Output Enable. Please refer to SP3489 Truth Table (2).

Pin 5 — RO₂ — Receiver 2 Output — If Receiver 2 output is enabled, if RI_{2A} > RI_{2B} by 200mV, Receiver 2 output is high. If Receiver 2 output is enabled, and if RI_{2A} < RI_{2B} by 200mV, Receiver 2 output is low.

Pin 6 — RI_{2A} — Receiver 2 input A.

Pin 7 — RI_{2B} — Receiver 2 input B.

Pin 8 — GND — Digital Ground.

DIFFERENTIAL A – B	ENABLES		OUTPUT RO
	EN	EN	
V _{ID} ≥ 0.2V	H X	X L	H H
-0.2V < V _{ID} < +0.2V	H X	X L	X X
V _{ID} ≤ 0.2V	H X	X L	L L
X	L	H	Hi-Z

Table 1. SP3488 Truth Table

Pin 9 — RI_{3B} — Receiver 3 input B.

Pin 10 — RI_{3A} — Receiver 3 input A.

Pin 11 — RO₃ — Receiver 3 Output — If Receiver 3 output is enabled, if RI_{3A} > RI_{3B} by 200mV, Receiver 3 output is high. If Receiver 3 output is enabled, and if RI_{3A} < RI_{3B} by 200mV, Receiver 3 output is low.

Pin 12 — EN3/EN4 — Receiver 3 and 4 Output Enable. Please refer to SP3489 Truth Table (2).

Pin 13 — RO₄ — Receiver 4 Output — If Receiver 4 output is enabled, if RI_{4A} > RI_{4B} by 200mV, Receiver 4 output is high. If Receiver 4 output is enabled, and if RI_{4A} < RI_{4B} by 200mV, Receiver 4 output is low.

Pin 14 — RI_{4A} — Receiver 4 input A.

Pin 15 — RI_{4B} — Receiver 4 input B.

Pin 16 — V_{cc} — Positive Supply +3.00V < V_{cc} < +3.60V

FEATURES...

The **SP3488** and the **SP3489** are +3.3V low power quad line receivers that meet the specifications of the RS-485 and RS-422 serial protocols. These devices are pin-to-pin compatible with Sipex's SP488 and SP489 devices as well as popular industry standards. The **SP3488** and **SP3489** devices feature Sipex's BiCMOS process allowing low power operation without sacrificing performance.

The RS-485 standard is ideal for multi-drop applications or for long distance interfaces. RS-485 allows up to 32 drivers and 32 receivers to be connected to a data bus, making it an ideal choice for multi-drop applications. Since the

DIFFERENTIAL A – B	ENABLES		OUTPUT RO
	EN ₁ /EN ₂ or EN ₃ /EN ₄		
V _{ID} ≥ 0.2V	H		H
-0.2V < V _{ID} < +0.2V	H		X
V _{ID} ≤ 0.2V	H		L
X	L		Hi-Z

Table 2. SP3489 Truth Table

cabling can be as long as 4,000 feet, RS-485 transceivers are equipped with a wide (-7V to +12V) common mode range to accommodate ground potential differences. Because the RS-485 protocol is a differential interface, data is virtually immune to noise in the transmission line.

Receiver...

The **SP3488** and the **SP3489** receivers have differential inputs with an input sensitivity as low as $\pm 100\text{mV}$. Input impedance of the receivers is typically $15\text{K}\Omega$ ($12\text{K}\Omega$ minimum). A wide common mode range of -7V to +12V allows for large ground potential differences between systems.

The **SP3488** features active HIGH and active LOW common receiver enable controls. Refer to **SP3488** Truth Table in *Table 1*. The **SP3489** provides independent, active high receiver enable controls for each pair of receivers. Refer to **SP3489** Truth Table in *Table 2*. Both devices feature tri-state outputs and a -7V to +12V common-mode input range permitting a $\pm 7\text{V}$ ground difference between devices on the communication bus. The **SP3488** and the **SP3489** are equipped with a fail-safe feature which forces a logic HIGH at the receiver output when the input is left floating. The **SP3488** and **SP3489** receivers meet the electrical specifications of RS-485 and RS-422 serial protocol data rates up to 10Mbps under load.

AC PARAMETERS

$V_{CC} = +3.3\text{V} \pm 5\%$; typicals at 25°C ; $T_{AMB} = 25^\circ\text{C}$ unless otherwise noted.

PARAMETER	MIN.	TYP.	MAX.	UNIT	CONDITIONS
PROPAGATION DELAY					
Receiver Input to Output					$C_L = 15\text{pF}$; <i>Figure 1, 3</i>
Low to HIGH (t_{PLH})		75	115	ns	
High to LOW (t_{PHL})		80	115	ns	
Differential Receiver Skew (t_{SKD})		4		ns	
Receiver Rise Time (t_R)					10% to 90%
SP3488		7	15	ns	
SP3489		7	15	ns	
Receiver Fall Time (t_F)					90% to 10%
SP3488		6	15	ns	
SP3489		6	15	ns	
RECEIVER ENABLE					
To Output HIGH		46	100	ns	$C_L = 15\text{pF}$; <i>Figures 2 and 4</i> (S2 closed)
To Output LOW		46	100	ns	
RECEIVER DISABLE					
From Output LOW		46	100	ns	$C_L = 15\text{pF}$; <i>Figures 2 and 4</i> (S1 closed)
From Output HIGH		46	100	ns	
					$C_L = 15\text{pF}$; <i>Figures 2 and 4</i> (S2 closed)

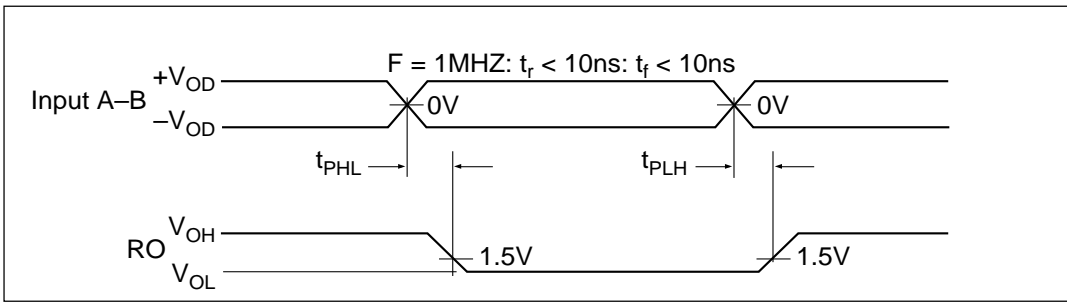

Figure 3. Receiver Propagation Delays

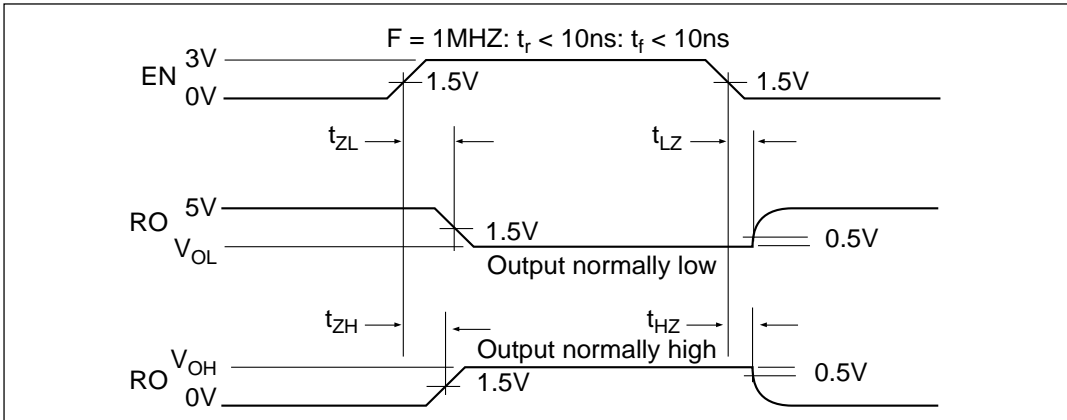
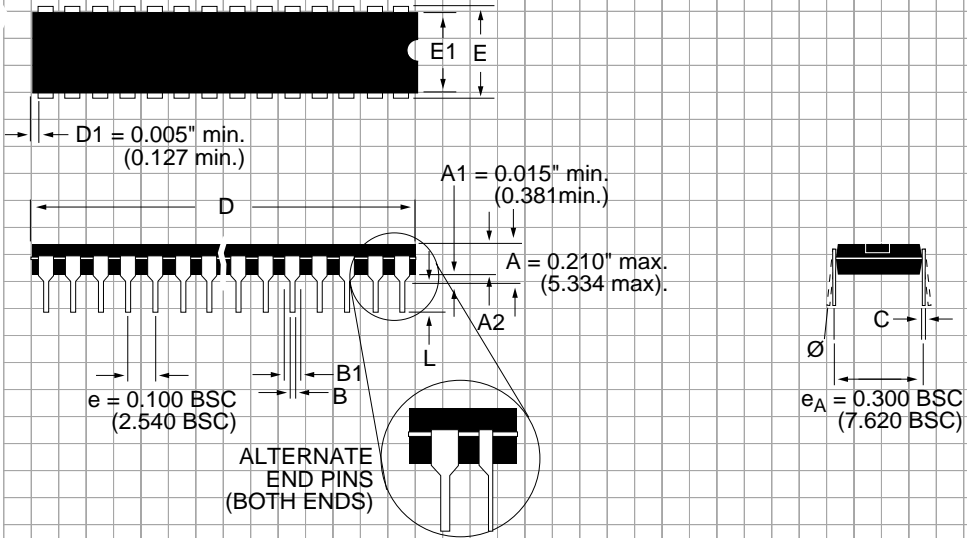

Figure 4. Receiver Enable/Disable Timing

PACKAGE: PLASTIC DUAL-IN-LINE (NARROW)



DIMENSIONS (Inches) Minimum/Maximum (mm)	16-PIN
A2	0.115/0.195 (2.921/4.953)
B	0.014/0.022 (0.356/0.559)
B1	0.045/0.070 (1.143/1.778)
C	0.008/0.014 (0.203/0.356)
D	0.780/0.800 (19.812/20.320)
E	0.300/0.325 (7.620/8.255)
E1	0.240/0.280 (6.096/7.112)
L	0.115/0.150 (2.921/3.810)
\emptyset	0°/15° (0°/15°)

**PACKAGE: PLASTIC
SMALL OUTLINE (SOIC)
(WIDE)**

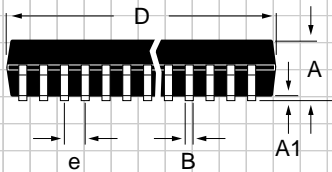
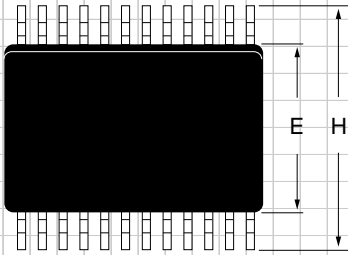

DIMENSIONS (Inches) Minimum/Maximum (mm)	16-PIN
A	0.093/0.104 (2.352/2.649)
A1	0.004/0.012 (0.102/0.300)
B	0.013/0.020 (0.330/0.508)
D	0.398/0.413 (10.10/10.49)
E	0.291/0.299 (7.402/7.600)
e	0.050 BSC (1.270 BSC)
H	0.394/0.419 (10.00/10.64)
L	0.016/0.050 (0.406/1.270)
Ø	0°/8° (0°/8°)

ORDERING INFORMATION

Quad RS485 Receivers:

Model	Enable/Disable	Temperature Range	Package
SP3488CP	Common; active Low and Active High	0°C to +70°C	16-pin Plastic DIP
SP3488CT	Common; active Low and Active High	0°C to +70°C	16-pin SOIC
SP3488EP	Common; active Low and Active High	-40°C to +85°C	16-pin Plastic DIP
SP3488ET	Common; active Low and Active High	-40°C to +85°C	16-pin SOIC
SP3489CP	One per driver pair; active High	0°C to +70°C	16-pin Plastic DIP
SP3489CT	One per driver pair; active High	0°C to +70°C	16-pin SOIC
SP3489EP	One per driver pair; active High	-40°C to +85°C	16-pin Plastic DIP
SP3489ET	One per driver pair; active High	-40°C to +85°C	16-pin SOIC

Please consult the factory for pricing and availability on a Tape-On-Reel option.

Available in lead free packaging. To order, add "-L" suffix to the part number.
Example: SP3488CP = standard; SP3488CP -L = lead free.



SIGNAL PROCESSING EXCELLENCE

Sipex Corporation

Headquarters and Sales Office

233 South Hillview Drive
Milpitas, CA 95035
TEL: (408) 934-7500
FAX: (408) 935-7600

Sales Office

22 Linnell Circle
Billerica, MA 01821
TEL: (978) 667-8700
FAX: (978) 670-9001
e-mail: sales@sipex.com

Sipex Corporation reserves the right to make changes to any products described herein. Sipex does not assume any liability arising out of the application or use of any product or circuit described hereing; neither does it convey any license under its patent rights nor the rights of others.