

SN54AHC04, SN74AHC04 HEX INVERTERS

SCLS234A – OCTOBER 1995 – REVISED MARCH 1996

- Operating Range 2-V to 5.5-V V_{CC}
- EPIC™ (Enhanced-Performance Implanted CMOS) Process
- Unbuffered Outputs
- High Latch-Up Immunity Exceeds 250 mA Per JEDEC Standard JESD-17
- ESD Protection Exceeds 2000 V Per MIL-STD-883C, Method 3015; Exceeds 200 V Using Machine Model (C = 200 pF, R = 0)
- Package Options Include Plastic Small-Outline (D), Shrink Small-Outline (DB), Thin Shrink Small-Outline (PW), and Ceramic Flat (W) Packages, Ceramic Chip Carriers (FK), and Standard Plastic (N) and Ceramic (J) 300-mil DIPs

description

The 'AHC04 contain six independent inverters. These devices perform the Boolean function $Y = \bar{A}$. Internal circuitry consists of single-stage inverters that can be used in analog applications such as crystal oscillators.

The SN54AHC04 is characterized for operation over the full military temperature range of -55°C to 125°C . The SN74AHC04 is characterized for operation from -40°C to 85°C .

SN54AHC04 ... J OR W PACKAGE
SN74AHC04 ... D, DB, N OR PW PACKAGE
(TOP VIEW)

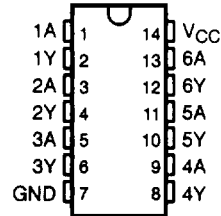

SN54AHC04 ... FK PACKAGE
(TOP VIEW)

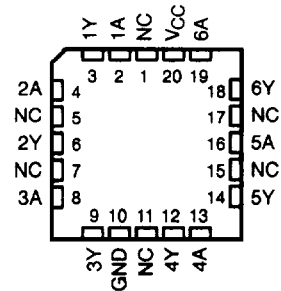

NC – No internal connection

FUNCTION TABLE
(each Inverter)

INPUT A	OUTPUT Y
H	L
L	H

logic symbol

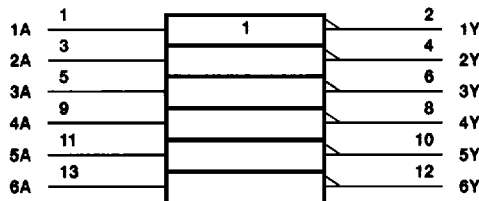

† This symbol is in accordance with ANSI/IEEE Std 91-1984 and IEC Publication 617-12. Pin numbers shown are for D, DB, J, N, PW, and W packages.

EPIC is a trademark of Texas Instruments Incorporated.

PRODUCTION DATA Information is current as of publication date. Products conform to specifications per the terms of Texas Instruments standard warranty. Production processing does not necessarily include testing of all parameters.

**TEXAS
INSTRUMENTS**

POST OFFICE BOX 655303 • DALLAS, TEXAS 75265

Copyright © 1996, Texas Instruments Incorporated

SN54AHC04, SN74AHC04 HEX INVERTERS

SCLS234A – OCTOBER 1995 – REVISED MARCH 1998

logic diagram (positive logic)



absolute maximum ratings over operating free-air temperature range (unless otherwise noted)†

Supply voltage range, V_{CC}	-0.5 V to 7 V
Input voltage range, V_I (see Note 1)	-0.5 V to 7 V
Output voltage range, V_O (see Note 1)	-0.5 V to $V_{CC} + 0.5$ V
Input clamp current, I_{IK} ($V_I < 0$)	-20 mA
Output clamp current, I_{OK} ($V_O < 0$ or $V_O > V_{CC}$)	±20 mA
Continuous output current, I_O ($V_O = 0$ to V_{CC})	±25 mA
Continuous current through V_{CC} or GND	±50 mA
Maximum power dissipation at $T_A = 55^\circ\text{C}$ (in still air) (see Note 2): D package	1.25 W
DB or PW package	0.5 W
N package	1.1 W
Storage temperature range, T_{stg}	-65°C to 150°C

† Stresses beyond those listed under "absolute maximum ratings" may cause permanent damage to the device. These are stress ratings only, and functional operation of the device at these or any other conditions beyond those indicated under "recommended operating conditions" is not implied. Exposure to absolute-maximum-rated conditions for extended periods may affect device reliability.

NOTES: 1. The input and output voltage ratings may be exceeded if the input and output current ratings are observed.

2. The maximum package power dissipation is calculated using a junction temperature of 150°C and a board trace length of 750 mils, except for the N package, which has a trace length of zero.

recommended operating conditions (see Note 3)

		SN54AHC04		SN74AHC04		UNIT
		MIN	MAX	MIN	MAX	
V_{CC}	Supply voltage	2	5.5	2	5.5	V
V_{IH}	High-level input voltage	$V_{CC} = 2$ V		1.7		V
		$V_{CC} = 3$ V		2.4		
		$V_{CC} = 5.5$ V		4.4		
V_{IL}	Low-level input voltage	$V_{CC} = 2$ V		0.3		V
		$V_{CC} = 3$ V		0.6		
		$V_{CC} = 5.5$ V		1.1		
V_I	Input voltage	0	5.5	0	5.5	V
V_O	Output voltage	0	V_{CC}	0	V_{CC}	V
I_{OH}	High-level output current	$V_{CC} = 2$ V		-50		μA
		$V_{CC} = 3.3$ V ± 0.3 V		-4		
		$V_{CC} = 5$ V ± 0.5 V		-8		
I_{OL}	Low-level output current	$V_{CC} = 2$ V		50		μA
		$V_{CC} = 3.3$ V ± 0.3 V		4		
		$V_{CC} = 5$ V ± 0.5 V		8		
T_A	Operating free-air temperature	-55	125	-40	85	°C

NOTE 3: Unused inputs must be held high or low to prevent them from floating.



SN54AHC04, SN74AHC04 HEX INVERTERS

SCLS234A – OCTOBER 1995 – REVISED MARCH 1996

electrical characteristics over recommended operating free-air temperature range (unless otherwise noted)

PARAMETER	TEST CONDITIONS	V _{CC}	T _A = 25°C			SN54AHC04		SN74AHC04		UNIT
			MIN	TYP	MAX	MIN	MAX	MIN	MAX	
V _{OH}	I _{OH} = -50 μA	2 V	1.8	2		1.8	1.8		V	
		3 V	2.7	3		2.7	2.7			
		4.5 V	4	4.5		4	4			
	I _{OH} = -4 mA	3 V	2.58		2.48		2.48			
	I _{OH} = -8 mA	4.5 V	3.94		3.8		3.8			
V _{OL}	I _{OL} = 50 μA	2 V			0.2	0.2	0.2		V	
		3 V			0.3	0.3	0.3			
		4.5 V			0.5	0.5	0.5			
	I _{OL} = 4 mA	3 V			0.36	0.5	0.44			
	I _{OL} = 8 mA	4.5 V			0.36	0.5	0.44			
I _I	V _I = V _{CC} or GND	5.5 V			±0.1			±1	μA	
I _{CC}	V _I = V _{CC} or GND, I _O = 0	5.5 V			2			20	μA	
C _I	V _I = V _{CC} or GND	5 V		2	10			10	pF	

switching characteristics over recommended operating free-air temperature range, V_{CC} = 3.3 V ± 0.3 V (unless otherwise noted) (see Figure 1)

PARAMETER	FROM (INPUT)	TO (OUTPUT)	OUTPUT CAPACITANCE	SN54AHC04					UNIT	
				T _A = 25°C			MIN	MAX		
				MIN	TYP	MAX				
t _{PLH} *	A	Y	C _L = 15 pF	5	8.9		1	10.5	ns	
t _{PHL} *				5	8.9		1	10.5		
t _{PLH}	A	Y	C _L = 50 pF	7.5	11.4		1	13	ns	
t _{PHL}				7.5	11.4		1	13		

* On products compliant to MIL-PRF-38535, this parameter is ensured but not production tested.

switching characteristics over recommended operating free-air temperature range, V_{CC} = 3.3 V ± 0.3 V (unless otherwise noted) (see Figure 1)

PARAMETER	FROM (INPUT)	TO (OUTPUT)	OUTPUT CAPACITANCE	SN74AHC04					UNIT	
				T _A = 25°C			MIN	MAX		
				MIN	TYP	MAX				
t _{PLH}	A	Y	C _L = 15 pF	5	8.9		1	10.5	ns	
t _{PHL}				5	8.9		1	10.5		
t _{PLH}	A	Y	C _L = 50 pF	7.5	11.4		1	13	ns	
t _{PHL}				7.5	11.4		1	13		



SN54AHC04, SN74AHC04 HEX INVERTERS

SCLS234A – OCTOBER 1995 – REVISED MARCH 1996

switching characteristics over recommended operating free-air temperature range,
 $V_{CC} = 5\text{ V} \pm 0.5\text{ V}$ (unless otherwise noted) (see Figure 1)

PARAMETER	FROM (INPUT)	TO (OUTPUT)	OUTPUT CAPACITANCE	SN54AHC04				UNIT	
				$T_A = 25^\circ\text{C}$			MIN		MAX
				MIN	TYP	MAX			
t_{PLH}^*	A	Y	$C_L = 15\text{ pF}$	3.5	5.5	1	6.5	ns	
t_{PHL}^*				3.5	5.5	1	6.5		
t_{PLH}	A	Y	$C_L = 50\text{ pF}$	5	7	1	8	ns	
t_{PHL}				5	7	1	8		

* On products compliant to MIL-PRF-38535, this parameter is ensured but not production tested.

switching characteristics over recommended operating free-air temperature range,
 $V_{CC} = 5\text{ V} \pm 0.5\text{ V}$ (unless otherwise noted) (see Figure 1)

PARAMETER	FROM (INPUT)	TO (OUTPUT)	OUTPUT CAPACITANCE	SN74AHC04				UNIT	
				$T_A = 25^\circ\text{C}$			MIN		MAX
				MIN	TYP	MAX			
t_{PLH}	A	Y	$C_L = 15\text{ pF}$	3.5	5.5	1	6.5	ns	
t_{PHL}				3.5	5.5	1	6.5		
t_{PLH}	A	Y	$C_L = 50\text{ pF}$	5	7	1	8	ns	
t_{PHL}				5	7	1	8		

noise characteristics, $V_{CC} = 5\text{ V}$, $C_L = 50\text{ pF}$, $T_A = 25^\circ\text{C}$ (see Note 4)

PARAMETER		SN74AHC04			UNIT
		MIN	TYP	MAX	
$V_{OL(P)}$	Quiet output, maximum dynamic V_{OL}	0.5			V
$V_{OL(V)}$	Quiet output, minimum dynamic V_{OL}	-0.5			V
$V_{OH(V)}$	Quiet output, minimum dynamic V_{OH}	4.3			V
$V_{IH(D)}$	High-level dynamic input voltage	4			V
$V_{IL(D)}$	Low-level dynamic input voltage			1	V

NOTE 4: Characteristics are determined during product characterization and ensured by design for surface-mount packages only.

operating characteristics, $V_{CC} = 5\text{ V}$, $T_A = 25^\circ\text{C}$

PARAMETER		TEST CONDITIONS	TYP	UNIT
C_{pd}	Power dissipation capacitance	No load, $f = 1\text{ MHz}$	7.3	pF



PARAMETER MEASUREMENT INFORMATION

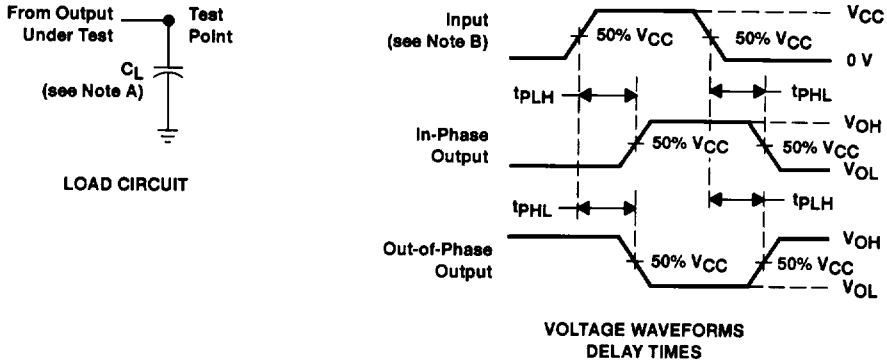

- NOTES: A. C_L includes probe and jig capacitance.
 B. All input pulses are supplied by generators having the following characteristics: $PRR \leq 1 \text{ MHz}$, $Z_O = 50 \Omega$, $t_r = 3 \text{ ns}$, $t_f = 3 \text{ ns}$.
 C. The outputs are measured one at a time with one input transition per measurement.

Figure 1. Load Circuit and Voltage Waveforms