

## 400MHz Quadrature Modulator and AGC

January 1998

### Features

- Integrates all IF Transmit Functions
- Broad Frequency Range ..... 10MHz to 400MHz
- I/Q Amplitude and Phase Balance ..... 0.2dB, 2°
- 5th Order Programmable Low Pass Filter. .... 2.2MHz - 17.6MHz
- 400MHz Output AGC Amplifier/Attenuator ..... .45dB
- Selectable Digital or Analog TX Baseband Inputs
- Low LO Drive Level ..... -15dBm
- Fast Transmit-on Switching ..... 1μs
- Power Management/Standby Mode
- Single Supply 2.7V to 5.5V Operation

### Applications

- Wireless Local Loop Systems
- Wireless Local Area Networks
- PCMCIA Wireless Duplex Transceivers
- ISM Systems
- TDMA Packet Protocol Radios
- PCS/Wireless PBX



### Description

The HFA3763 is a highly integrated baseband converter for quadrature modulation applications. The HFA3763 400MHz quadrature modulator and AGC is one of the seven chips in the Prism™ full duplex chip set (see Typical Application Diagram). It features all the necessary blocks for baseband modulation of I and Q signals. An output AGC and Baseband shaping filters are integrated in the design. Four filter bandwidths are programmable via a two bit digital control interface. In addition, these filters are continuously tunable over a ±20% frequency range via one external resistor. The modulator channel receives digital or analog I and Q data for processing. To achieve broadband operation, the Local Oscillator frequency input is required to be twice the desired frequency of modulation. A selectable buffered divide by 2 LO output and a stable reference voltage are provided for convenience of the user.

### Ordering Information

PART NUMBER	TEMP. RANGE (°C)	PACKAGE	PKG. NO.
HFA3763IN	-40 to 85	80 Ld TQFP	Q80.14x14

### Simplified Block Diagram

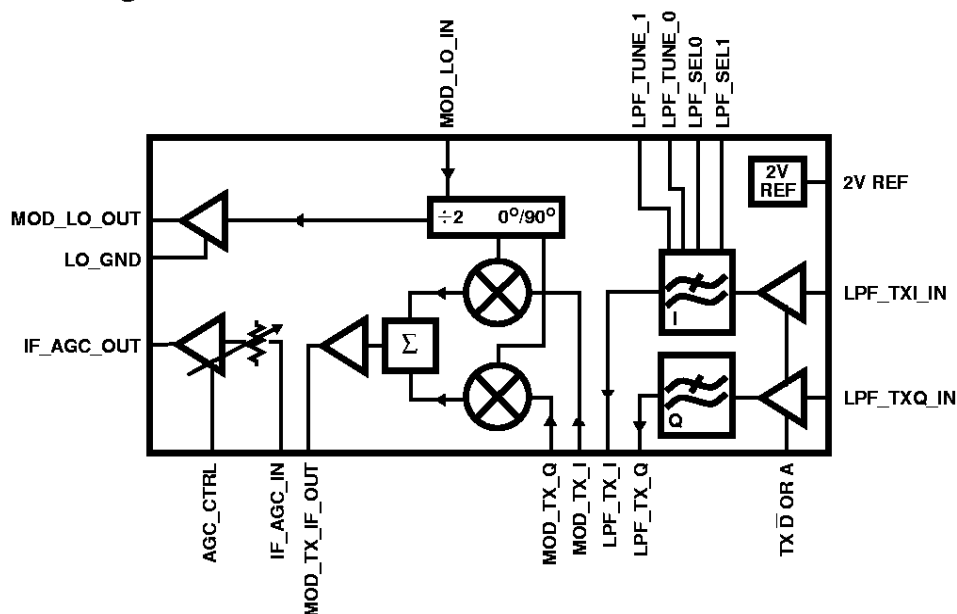

PRISM™ and the PRISM™ logo are registered trademarks of Harris Corporation

# HFA3763

## Pinout

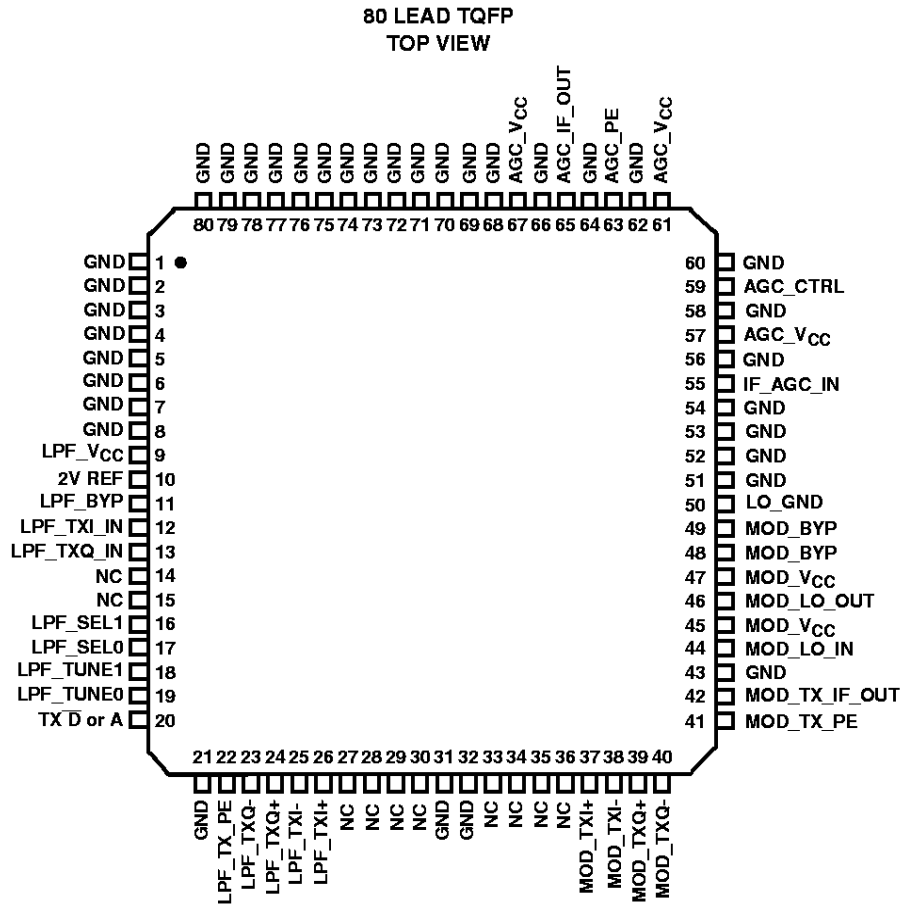

## Typical Application Diagram

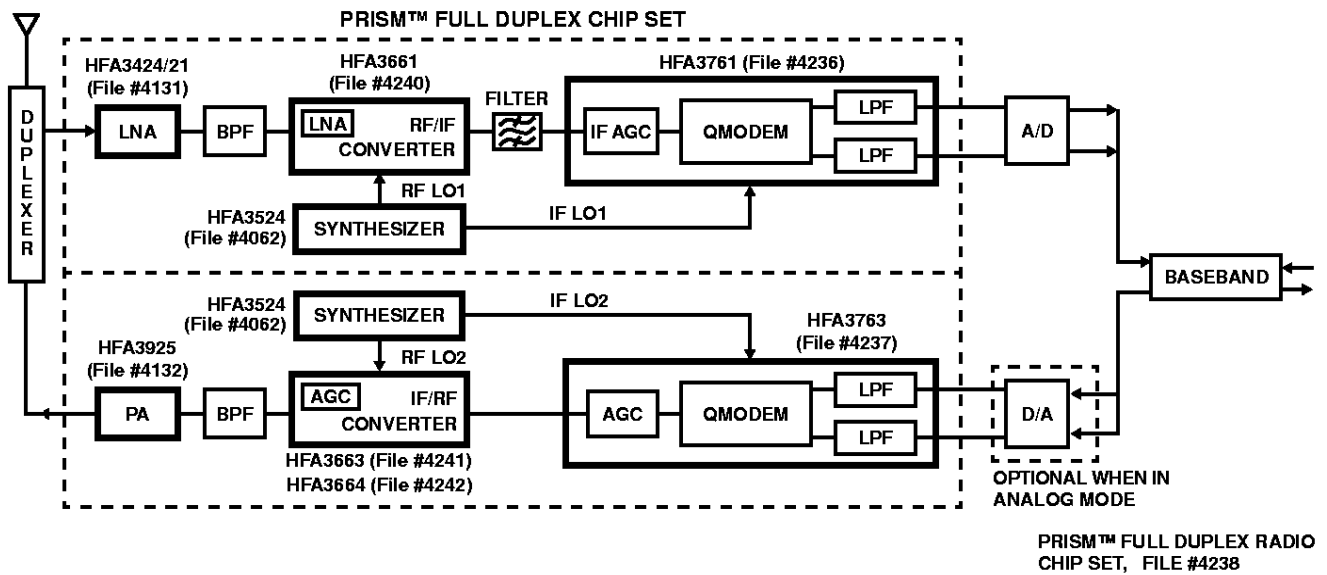

Block Diagram

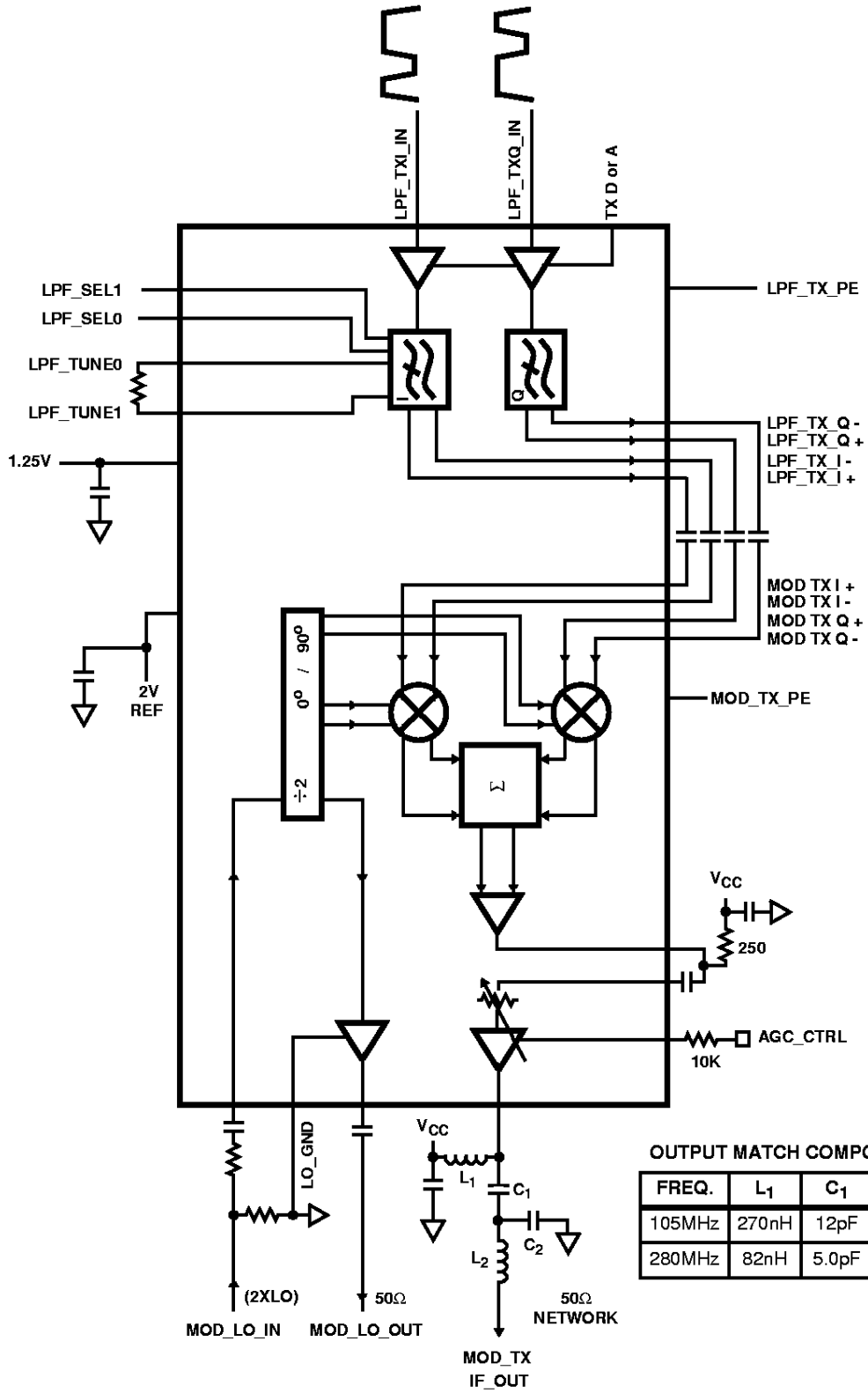

OUTPUT MATCH COMPONENTS TABLE

FREQ.	L <sub>1</sub>	C <sub>1</sub>	L <sub>2</sub>	C <sub>2</sub>
105MHz	270nH	12pF	82nH	15pF
280MHz	82nH	5.0pF	33nH	6.0pF

NOTE: V<sub>CC</sub>, GND and Bypass capacitors not shown.

## HFA3763

### Pin Descriptions

PIN	SYMBOL	DESCRIPTION																		
9	LPF_VCC	Supply pin for the Low pass filter. Use high quality decoupling capacitors right at the pin.																		
10	2V REF	Stable 2V reference voltage output for external applications. Loading must be higher than 10kΩ. A bypass capacitor of at least 0.1μF is required.																		
11	LPF_BYP	Internal reference bypass pin. This is the common voltage (V <sub>CM</sub> ) used for the LPF digital thresholds. Requires 0.1μF decoupling capacitor.																		
12	LPF_TXI_In	Low pass filter in phase (I) channel transmit input. Conventional or attenuated direct coupling is required for digital inputs. AC couple for analog input.																		
13	LPF_TXQ_In	Low pass filter quadrature (Q) channel transmit input. Conventional or attenuated direct coupling is required for digital inputs. AC couple for analog input.																		
14	NC	Connected internally for test purpose. Leave this pin floating.																		
15	NC	Connected internally for test purpose. Leave this pin floating.																		
16	LPF_Sel1	Digital control input pins. Selects four programmed cut off frequencies for the transmit channel. Tuning speed from one cutoff to another is less than 1μs.																		
17	LPF_Sel0																			
		<table style="width: 100%; border-collapse: collapse;"> <thead> <tr> <th>SEL1</th> <th>SEL0</th> <th>CUTOFF FREQUENCY</th> <th>SEL1</th> <th>SEL0</th> <th>CUTOFF FREQUENCY</th> </tr> </thead> <tbody> <tr> <td>LO</td> <td>LO</td> <td>2.2MHz</td> <td>HI</td> <td>LO</td> <td>8.8MHz</td> </tr> <tr> <td>LO</td> <td>HI</td> <td>4.4MHz</td> <td>HI</td> <td>HI</td> <td>17.6MHz</td> </tr> </tbody> </table>	SEL1	SEL0	CUTOFF FREQUENCY	SEL1	SEL0	CUTOFF FREQUENCY	LO	LO	2.2MHz	HI	LO	8.8MHz	LO	HI	4.4MHz	HI	HI	17.6MHz
SEL1	SEL0	CUTOFF FREQUENCY	SEL1	SEL0	CUTOFF FREQUENCY															
LO	LO	2.2MHz	HI	LO	8.8MHz															
LO	HI	4.4MHz	HI	HI	17.6MHz															
18	LPF_Tune1	These two pins are used to fine tune the Low pass filter cutoff frequency. A resistor connected between the two pins (R <sub>TUNE</sub> ) will fine tune the transmit filters. Refer to the tuning equation in the LPF AC specifications.																		
19	LPF_Tune0																			
20	TX $\bar{D}$ or A	Selects the configuration of the Transmit baseband input for either Digital or Analog (500mV <sub>p-p</sub> max). Tie to a High for Analog and Ground for Digital inputs. Requires decoupling capacitor for analog and a simple direct coupled attenuator for digital inputs.																		
22	LPF_TX_PE	Digital input control pin to enable the LPF transmit mode of operation. Enable logic level is High.																		
23	LPF_TXQ-	Negative output of the transmit Low pass filter, quadrature channel. AC coupling is required. Normally connects to the inverting input of the quadrature Modulator (Mod_TXQ-), pin 40.																		
24	LPF_TXQ+	Positive output of the transmit Low pass filter, quadrature channel. AC coupling is required. Normally connects to the non inverting input of the quadrature Modulator (Mod_TXQ+), pin 39.																		
25	LPF_TXI-	Negative output of the transmit Low pass filter, in phase channel. AC coupling is required. Normally connects to the inverting input of the in phase Modulator (Mod_TXI-), pin 38.																		
26	LPF_TXI+	Positive output of the transmit Low pass filter, in phase channel. AC coupling is required. Normally connects to the non inverting input of the in phase Modulator (Mod_TXI+), pin 37.																		
27	NC	Connected internally for test purpose. Leave this pin floating.																		
28	NC	Connected internally for test purpose. Leave this pin floating.																		
29	NC	Connected internally for test purpose. Leave this pin floating.																		
30	NC	Connected internally for test purpose. Leave this pin floating.																		
33	NC	Connected internally for test purpose. Leave this pin floating.																		
34	NC	Connected internally for test purpose. Leave this pin floating.																		
35	NC	Connected internally for test purpose. Leave this pin floating.																		
36	NC	Connected internally for test purpose. Leave this pin floating.																		

## HFA3763

### Pin Descriptions (Continued)

PIN	SYMBOL	DESCRIPTION
37	Mod_TXI+	In phase modulator non inverting input. AC coupling is required. This input is normally coupled to the Low pass filter positive output (LPF_TXI+), pin 26.
38	Mod_TXI-	In phase modulator inverting input. AC coupling is required. This input is normally coupled to the Low pass filter negative output (LPF_TXI-), pin 25.
39	Mod_TXQ+	Quadrature modulator non inverting input. AC coupling is required. This input is normally coupled to the Low pass filter positive output (LPF_TXQ+), pin 24.
40	Mod_TXQ-	Quadrature modulator inverting input. AC coupling is required. This input is normally coupled to the Low pass filter negative output (LPF_TXQ-), pin 23.
41	Mod_TX_PE	Digital input control to enable the Modulator section. Enable logic level is High for transmit.
42	Mod_TX_IF_Out	Modulator open collector output, single ended. Termination resistor to $V_{CC}$ with a typical value of 250 $\Omega$ .
44	Mod_LO_In (2XLO)	Single ended local oscillator current input. Frequency of input signal must be twice the required modulator carrier LO frequency. Input current is optimum at 200 $\mu A_{RMS}$ . Input matching networks and filters can be designed for a wide range of power and impedances at this port. Typical input impedance is 130 $\Omega$ . This pin requires AC coupling. NOTE: High second harmonic content input waveforms may degrade I/Q phase accuracy.
45	Mod_V <sub>CC</sub>	Modulator supply pin. Use high quality decoupling capacitors right at the pin.
46	Mod_LO_Out	Divide by 2 buffered output reference from "Mod_LO_in" input. Used for external applications where the modulating and demodulating carrier reference frequency is required. 50 $\Omega$ single end driving capability. AC coupling is required. This output can be disabled by shorting to $V_{CC}$ or floating pin 50.
47	Mod_V <sub>CC</sub>	Modulator supply pin. Use high quality decoupling capacitors right at the pin.
48	MOD_BYP	This pin must be connected to pin 49 and decoupled to GND.
49	MOD_BYP	This pin must be connected to pin 48.
50	LO_GND	When grounded, this pin enables the LO buffer (Mod_LO_Out). When open (NC) it disables the LO buffer.
55	IF_AGC_IN	AC coupled input to the AGC amplifier.
57	AGC_V <sub>CC</sub>	AGC supply pin supply pin. Use high quality decoupling capacitors right at the pin.
59	AGC_CTRL	AGC control DC control voltage input requires external resistor to set scale factor. 10K for optimum temp. co.. May require decoupling filtering capacitor.
61	AGC_V <sub>CC</sub>	AGC supply pin supply pin. Use high quality decoupling capacitors right at the pin.
63	AGC_PE	Digital input control for the AGC amplifier. Enable logic level is High.
65	AGC_IF_OUT	AGC amplifier output. Output impedance of 250 $\Omega$ . Need to be connected to $V_{CC}$ by an inductor with reactance well above 250 $\Omega$ .
67	AGC_V <sub>CC</sub>	AGC supply pin supply pin. Use high quality decoupling capacitors right at the pin.
See Pinout	GND	All remaining pins not listed above must be connected to a solid ground plane.

# HFA3763

## Absolute Maximum Ratings $T_A = 25^\circ\text{C}$

Supply Voltage ..... -0.3V to +6.0V  
 Voltage on Any Other Pin ..... -0.3V to  $V_{CC} + 0.3\text{V}$

## Operating Conditions

Supply Voltage Range ..... +2.7V to +5.5V  
 Operating Temperature Range .....  $-40^\circ\text{C} \leq T_A \leq 85^\circ\text{C}$

## Thermal Information

Thermal Resistance (Typical, Note 1)  $\theta_{JA}$  ( $^\circ\text{C}/\text{W}$ )  
 TQFP Package ..... 75  
 Package Power Dissipation at  $70^\circ\text{C}$   
 Plastic TQFP Package ..... 1.1W  
 Maximum Junction Temperature (Plastic Package) .....  $150^\circ\text{C}$   
 Maximum Storage Temperature Range .....  $-65 \leq T_A \leq 150$   
 Maximum Lead Temperature (Soldering 10s) .....  $300^\circ\text{C}$   
 (TQFP - Lead Tips Only)

*CAUTION: Stresses above those listed in "Absolute Maximum Ratings" may cause permanent damage to the device. This is a stress only rating and operation of the device at these or any other conditions above those indicated in the operational sections of this specification is not implied.*

### NOTE:

- $\theta_{JA}$  is measured with the component mounted on an evaluation PC board in free air.

## Cascaded DC Electrical Specifications $V_{CC} = 4.5\text{V}$ to $5.5\text{V}$ , Unless Otherwise Specified

PARAMETER	(NOTE 2) TEST LEVEL	TEMP ( $^\circ\text{C}$ )	MIN	TYP	MAX	UNITS
Total Supply Current, TX Mode at 5.5V	A	Full	-	80	106	mA
Shutdown Current at 5.5V	A	Full	-	0.8	1.0	mA
All Digital Inputs $V_{IH}$ (TTL Threshold for All $V_{CC}$ )	A	Full	2.0		$V_{CC}$	V
All Digital Inputs $V_{IL}$ (TTL Threshold for All $V_{CC}$ )	A	Full	-0.2		0.8	V
High Level Input Current at 5.5V $V_{CC}$ for pin 16 with $V_{IN} = 2.4\text{V}$	A	Full	-200	-65	0	$\mu\text{A}$
High Level Input Current at 5.5V $V_{CC}$ for pin 16 with $V_{IN} = 4.0\text{V}$	A	Full	-150	-30	0	$\mu\text{A}$
Low Level Input Current at 5.5V $V_{CC}$ for pin 16 with $V_{IN} = 0.8\text{V}$	A	Full	-300	-95	0	$\mu\text{A}$
High Level Input Current at 5.5V $V_{CC}$ for pins 17, 20, and 22 with $V_{IN} = 2.4\text{V}$	A	Full	0	50	200	$\mu\text{A}$
High Level Input Current at 5.5V $V_{CC}$ for pins 17, 20, and 22 with $V_{IN} = 4.0\text{V}$	A	Full	0	80	300	$\mu\text{A}$
Low Level Input Current at 5.5V $V_{CC}$ for pins 17, 20, and 22 with $V_{IN} = 0.8\text{V}$	A	Full	0	15	150	$\mu\text{A}$
High Level Input Current at 5.5V $V_{CC}$ for pins 41 and 63 with $V_{IN} = 2.4\text{V}$	A	Full	-20	1	20	$\mu\text{A}$
High Level Input Current at 5.5V $V_{CC}$ for pin 41 with $V_{IN} = 4.0\text{V}$	A	Full	0	110	300	$\mu\text{A}$
High Level Input Current at 5.5V $V_{CC}$ for pin 63 with $V_{IN} = 4.0\text{V}$	A	Full	-20	1.5	20	$\mu\text{A}$
Low Level Input Current at 5.5V $V_{CC}$ for pins 41 and 63 with $V_{IN} = 0.8\text{V}$	A	Full	-20	.1	20	$\mu\text{A}$
Power Down/Up Switching Speed	C	25	-	10	-	$\mu\text{s}$
Reference Voltage	A	Full	1.85	2.0	2.15	V
Reference Voltage Variation Over Temperature	B	Full	-	800	-	$\mu\text{V}/^\circ\text{C}$
Reference Voltage Variation Over Supply Voltage	B	25	-	1.6	-	mV/V
Reference Voltage Minimum Load Resistance	C	25	10	-	-	k $\Omega$

### NOTE:

- A = Production Tested, B = Based on Characterization, C = By Design

## Cascaded AC Electrical Specifications, Modulator Performance $V_{CC} = 4.5\text{V}$ to $5.5\text{V}$

PARAMETER	(NOTE 3) TEST LEVEL	TEMP ( $^\circ\text{C}$ )	MIN	TYP	MAX	UNITS
IF Modulator output power(Note 6)	A	25	-4	1	6	dBm
IF Modulator output P1dB	A	TBD	TBD	TBD	TBD	dBm
IF Modulator I/Q Amplitude Balance (Note 4)	B	Full	-1.0	0	+1.0	dB
IF Modulator I/Q Phase Balance (Note 4)	B	Full	-4.0	0	+4.0	Degrees
IF Modulator Side Band Suppression at 105MHz (Note 5)	A	Full	25	41	-	dBc
	A	25	33	41	-	dBc
IF Modulator Side Band Suppression at 400MHz	C	25	28	-	-	dBc
IF Mod Carrier Suppression (LO Buffer Enabled) (Note 5)	C	25	28	30	-	dBc

## HFA3763

### Cascaded AC Electrical Specifications, Modulator Performance $V_{CC} = 4.5V$ to $5.5V$ (Continued)

PARAMETER	(NOTE 3) TEST LEVEL	TEMP (°C)	MIN	TYP	MAX	UNITS
IF Mod Carrier Suppression (LO Buffer Disabled) (Note 5)	A	25	28	38	-	dBc
IF Modulator I/Q 3dB Cutoff SEL0/1 = 2.2MHz	B	25	1.98	2.2	2.42	MHz
IF Modulator I/Q 3dB Cutoff SEL0/1 = 4.4MHz	B	25	3.96	4.4	4.84	MHz
IF Modulator I/Q 3dB Cutoff SEL0/1 = 8.8MHz	B	25	7.92	8.8	9.68	MHz
IF Modulator I/Q 3dB Cutoff SEL0/1 = 17.6MHz	B	25	15.84	17.6	19.36	MHz

NOTES:

3. A = Production Tested, B = Based on Characterization, C = By Design
4. Data is characterized by DC levels applied to MOD TXI and Q pins for 4 quadrants with LO output as reference or indirectly by the SSB characteristics.
5. Analog mode with an input frequency of 1MHz and an input amplitude of  $400mV_{P-P}$  and a 2.2MHz lowpass filter cutoff with  $V_{AGC} = 1.25V$ .
6. Data is characterized with  $V_{AGC} = 1V$  with an input of  $400mV_{P-P}$  at LPF\_TXI\_IN and LPF\_TXQ\_IN.

### DC/AC Electrical Specifications AGC/Attenuator, Individual Performance

$V_{CC} = 4.5V$  to  $5.5V$  Unless Otherwise Specified

PARAMETER	(NOTE 7) TEST LEVEL	TEMP (°C)	MIN	TYP	MAX	UNITS
<b>DC ELECTRICAL SPECIFICATIONS AGC ATTENUATOR INDIVIDUAL PERFORMANCE</b>						
AGC Scale Factor at 100MHz at 3dB	A	25	36	45	54	dB/V
AGC Linearity: Max-to-Min Scale Factor at 0dB to 45dB AGC with External 10k $\Omega$	A	25	0.9:1	2:1	3:1	-
AGC Control Input for 45dB Max Attenuation with External 10k $\Omega$	A	25	1.7	2.0	2.5	V
AGC Control Input for -3 dB from Minimum Attenuation (Gain Approx. = 6dB) with External 10k $\Omega$	A	25	1.0	1.2	1.4	V
AGC Input Bias Current with External 10k $\Omega$ at -45 dB	A	Full	-	-	120	$\mu A$
<b>AC ELECTRICAL SPECIFICATIONS AGC ATTENUATOR INDIVIDUAL PERFORMANCE</b>						
Frequency Range	B	25	10	-	400	MHz
Power Gain at min AGC at 100MHz $V_{AGC} = 1.0V$	C	25	-	9.0	-	dB
Power Gain Temperature Coefficient $V_{AGC} = 1.0V$	B	25	-	+0.013	-	dB/deg
Output P1dB at Minimum AGC, 100MHz $V_{AGC} = 1.0V$	B	25	-	8.0	-	dBm
Output IP3 at Minimum AGC, 100MHz $V_{AGC} = 1.0V$	B	25	-	17.5	-	dBm
AGC/Attenuator Range	A	25	42	45	-	dB
AGC Settling Time to 1dB, 0dB to -40dB	C	25	-	-	10	$\mu s$
Output Impedance	C	25	-	250	-	$\Omega$
Input Impedance	C	25	-	250	-	$\Omega$
Gain Flatness, 20MHz Bandwidth	C	25	-	0.02	-	dB
Phase Shift vs AGC at 100MHz	C	25	-	-0.045	-	deg/dB
Power Down/Up Switching Speed (Note 3)	C	25	-	-	10	$\mu s$

NOTE:

7. A = Production Tested, B = Based on Characterization, C = By Design

### AC Electrical Specifications, I/Q Up Converter and LO Individual Performance

$V_{CC} = 4.5V$  to  $5.5V$  Unless Otherwise Specified

PARAMETER	(NOTE 8) TEST LEVEL	TEMP (°C)	MIN	TYP	MAX	UNITS
2XLO Input Frequency Range (2 X Input Range)	B	25	20	-	800	MHz
2XLO Input Current Range	C	25	50	200	300	$\mu A_{RMS}$
2XLO Input Impedance	C	25	-	130	-	$\Omega$

## HFA3763

### AC Electrical Specifications, I/Q Up Converter and LO Individual Performance

V<sub>CC</sub> = 4.5V to 5.5V Unless Otherwise Specified (Continued)

PARAMETER	(NOTE 8) TEST LEVEL	TEMP (°C)	MIN	TYP	MAX	UNITS
Buffered LO Output Voltage, Single Ended	A	25	80	100	-	mV <sub>P-P</sub>
Buffered LO Output Impedance	C	25	-	50	-	Ω
Quadrature IF Modulator Output Frequency Range	B	25	10	-	400	MHz
IF Modulator I/Q Input Frequency Range	C	25	-	-	30	MHz
IF Modulator Differential I/Q Max Input Voltage	C	25	-	2.25	-	V <sub>P-P</sub>
IF Modulator Differential I/Q Input Impedance	C	25	-	4	-	kΩ
IF Modulator Differential Input Capacitance	C	25	-	0.5	-	pF
IF Modulator I/Q Amplitude Balance	B	Full	-1.0	-	1.0	dB
IF Modulator I/Q Phase Balance at 105MHz	B	Full	-4	-	4	Degrees
IF Modulator I/Q Phase Balance at 400MHz	C	25	-4	-	4	Degrees
IF Modulator Carrier Suppression (LO Buffer Enabled)	C	25	28	30	-	dBc
IF Modulator Carrier Suppression (LO Buffer Disabled)	A	25	28	38	-	dBc
IF Modulator SSB Sideband Suppression at 105MHz	A	Full	25	41	-	dBc
	A	25	33	41	-	dBc
IF Modulator SSB Sideband Suppression at 400MHz	C	25	28	-	-	dBc
IF Output Level Compression Point	C	25	-	1.0	-	V <sub>P-P</sub>
IF Modulator Intermodulation Suppression	B	25	26	-	-	dBc

NOTE:

8. A = Production Tested, B = Based on Characterization, C = By Design

### AC Electrical Specifications, TX Buffer Individual Performance

V<sub>CC</sub> = 4.5V to 5.5V Unless Otherwise Specified

PARAMETER	(NOTE 9) TEST LEVEL	TEMP (°C)	MIN	TYP	MAX	UNITS
TX LPF Buffer Analog Input Range	A	25	-	500	-	mV <sub>P-P</sub>
TX LPF Buffer Analog/Digital Input Impedance	C	25	10	12.5	-	kΩ

NOTE:

9. A = Production Tested, B = Based on Characterization, C = By Design

### AC Electrical Specifications, RX/TX 5TH Order LPF Individual Performance

V<sub>CC</sub> = 4.5V to 5.5V Unless Otherwise Specified

PARAMETER	(NOTE 10) TEST LEVEL	TEMP (°C)	MIN	TYP	MAX	UNITS
TX LPF 3dB Bandwidth, Sel0 = 0, Sel1 = 0	B	25	1.98	2.20	2.42	MHz
TX LPF 3dB Bandwidth, Sel0 = 1, Sel1 = 0	B	25	3.96	4.40	4.84	MHz
TX LPF 3dB Bandwidth, Sel0 = 0, Sel1 = 1	B	25	7.92	8.80	9.68	MHz
TX LPF 3dB Bandwidth, Sel0 = 1, Sel1 = 1	B	25	15.84	17.60	19.36	MHz
TX LPF Sel0, Sel1 Tuning Speed	B	25	-	-	1	μs
TX LPF 3dB Bandwidth Tuning	B	25	-20	-	+20	%
LPF Tune Nominal Resistance	B	25	-	787	-	Ω
TX/RX LPF Total Harmonic Distortion	B	25	-	1	-	%
LPF Output Impedance, Single Ended	C	25	-	50	-	Ω

NOTE:

10. A = Production Tested, B = Based on Characterization, C = By Design

# HFA3763

TABLE 1. LOW PASS FILTER PROGRAMING AND TUNING INFORMATION

MODE	LPF SEL1	LPF SEL0	f <sub>3dB</sub> (NOMINAL R <sub>TUNE</sub> )
BW0	0	0	2.2MHz
BW1	0	1	4.4MHz
BW2	1	0	8.8MHz
BW3	1	1	17.6MHz

$$f_{TUNED\ 3dB} = \frac{f_{3dB\ NOMINAL} * 787}{R_{TUNE}}$$

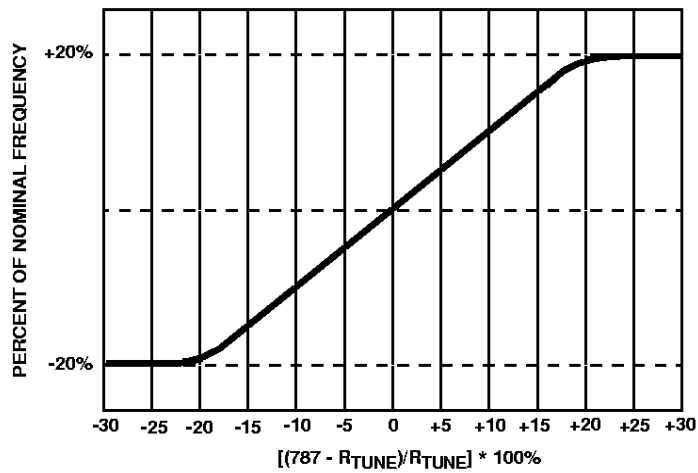

FREQUENCY	R <sub>TUNE</sub>
20% Low	984Ω
Nominal	787Ω
20% High	656Ω

FIGURE 1. TYPICAL f<sub>3dB</sub> vs R<sub>TUNE</sub>

**Thin Plastic Quad Flatpack Packages (TQFP)**

**Q80.14x14 (JEDEC MO-136BQ ISSUE C)  
80 LEAD THIN PLASTIC QUAD FLATPACK PACKAGE**

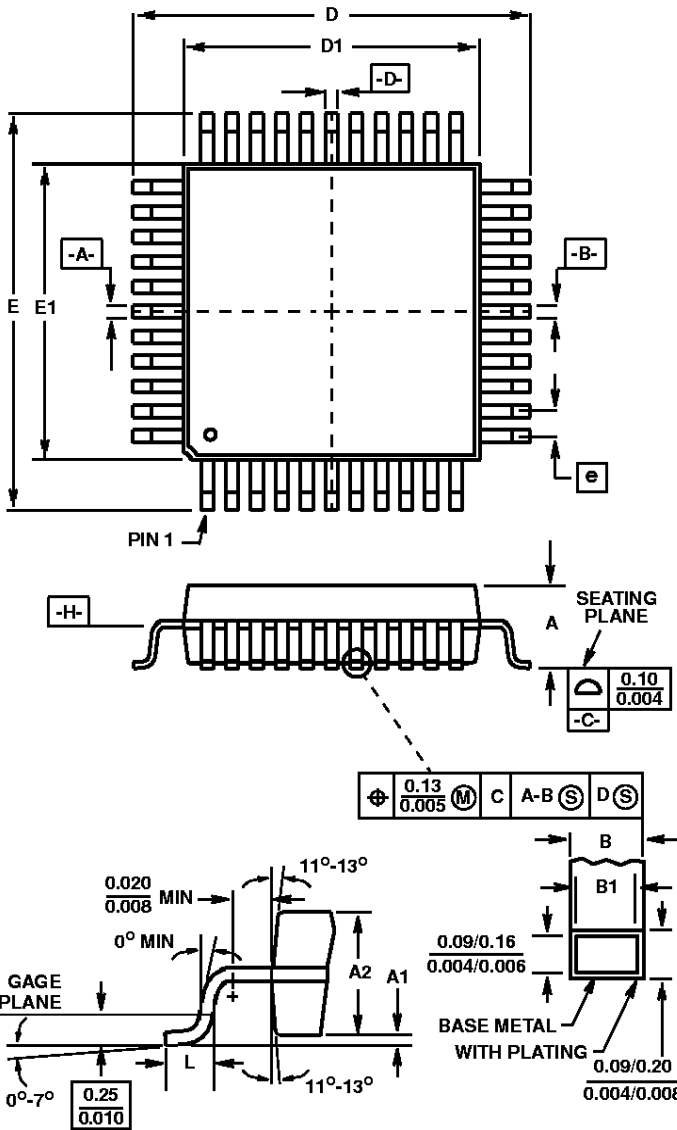

SYM-BOL	INCHES		MILLIMETERS		NOTES
	MIN	MAX	MIN	MAX	
A	-	0.062	-	1.60	-
A1	0.002	0.005	0.05	0.15	-
A2	0.054	0.057	1.35	1.45	-
B	0.009	0.014	0.22	0.38	6
B1	0.009	0.012	0.22	0.33	-
D	0.623	0.637	15.80	16.20	3
D1	0.544	0.559	13.80	14.20	4, 5
E	0.623	0.637	15.80	16.20	3
E1	0.544	0.559	13.80	14.20	4, 5
L	0.018	0.029	0.45	0.75	-
N	80		80		7
e	0.026 BSC		0.65 BSC		-

Rev. 1 4/95

**NOTES:**

1. Controlling dimension: MILLIMETER. Converted inch dimensions are not necessarily exact.
2. All dimensions and tolerances per ANSI Y14.5M-1982.
3. Dimensions D and E to be determined at seating plane **-C-**.
4. Dimensions D1 and E1 to be determined at datum plane **-H-**.
5. Dimensions D1 and E1 do not include mold protrusion. Allowable protrusion is 0.25mm (0.010 inch) per side.
6. Dimension B does not include dambar protrusion. Allowable dambar protrusion shall not cause the lead width to exceed the maximum B dimension by more than 0.08mm (0.003 inch).
7. "N" is the number of terminal positions.

All Harris Semiconductor products are manufactured, assembled and tested under **ISO9000** quality systems certification.

*Harris Semiconductor products are sold by description only. Harris Semiconductor reserves the right to make changes in circuit design and/or specifications at any time without notice. Accordingly, the reader is cautioned to verify that data sheets are current before placing orders. Information furnished by Harris is believed to be accurate and reliable. However, no responsibility is assumed by Harris or its subsidiaries for its use; nor for any infringements of patents or other rights of third parties which may result from its use. No license is granted by implication or otherwise under any patent or patent rights of Harris or its subsidiaries.*

**Sales Office Headquarters**

For general information regarding Harris Semiconductor and its products, call **1-800-4-HARRIS**

**NORTH AMERICA**  
Harris Semiconductor  
P. O. Box 883, Mail Stop 53-210  
Melbourne, FL 32902  
TEL: 1-800-442-7747  
(407) 729-4984  
FAX: (407) 729-5321

**EUROPE**  
Harris Semiconductor  
Mercure Center  
100, Rue de la Fusée  
1130 Brussels, Belgium  
TEL: (32) 2.724.2111  
FAX: (32) 2.724.22.05

**ASIA**  
Harris Semiconductor PTE Ltd.  
No. 1 Tannery Road  
Cencon 1, #09-01  
Singapore 1334  
TEL: (65) 748-4200  
FAX: (65) 748-0400

