

SANYO

No. 3523

VPH05**Video Pack, Video Output Amplifier
for High-definition TV and
Graphics Projectors****OVERVIEW**

The VPH05 is a composite, single-channel, video output amplifier IC for high-definition TV (HDTV) and video projectors. It is fabricated using hybrid technology and incorporates high-precision FBET and LSBT transistors to provide high output voltages over a wide bandwidth with minimal external components. The single-in-line, metal package reduces EMI and simplifies circuit board design.

The VPH05 is ideally suited to HDTV projectors which use a 32 to 64 kHz line frequency.

The VPH05 operates from a 170 V supply (typ) and is available in 9-pin SIPs.

FEATURES

- Up to 100 V_{p-p} output
- High-precision FBET and LSBT transistors
- 50 MHz bandwidth
- Low external component count
- Metal case reduces EMI
- Single-in-line package simplifies circuit board design
- Up to 230 V supply and 20 V bias
- 9-pin SIP

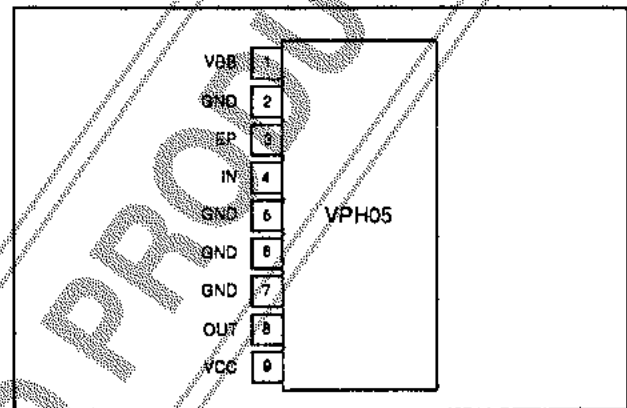
PINOUT**PACKAGE DIMENSIONS**

Unit: mm

2060

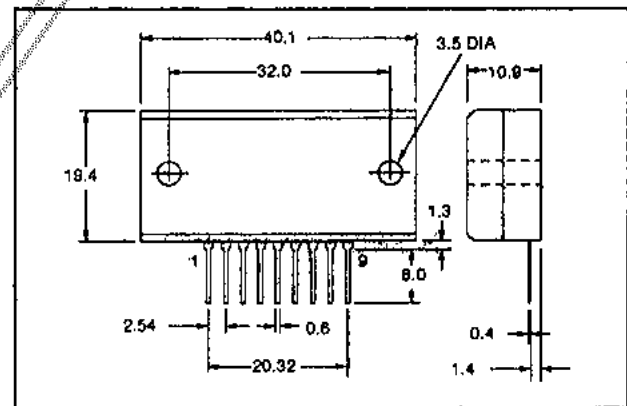

INTERNAL CIRCUIT

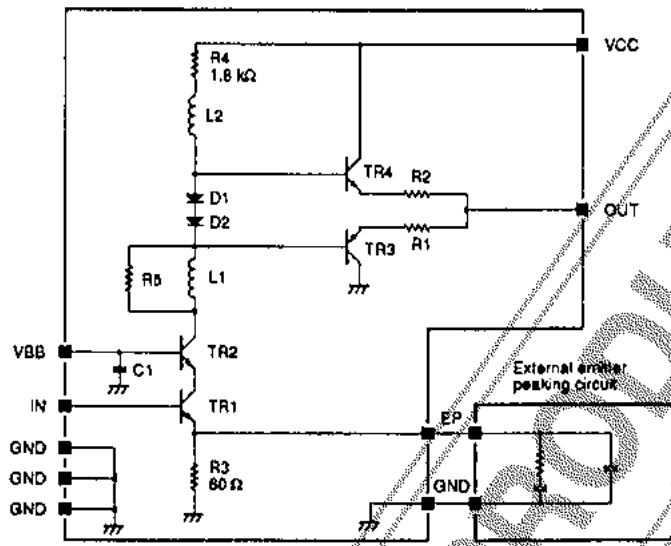

PIN DESCRIPTION

Number	Name	Description
1	VBB	Bias voltage
2, 5, 6, 7	GND	Ground
3	EP	External peaking input
4	IN	Input
8	OUT	Output
9	VCC	Supply voltage

SPECIFICATIONS

Absolute Maximum Ratings

Parameter	Symbol	Rating	Unit
Supply voltage	$V_{CC \text{ max}}$	230	V
Bias voltage	$V_{BB \text{ max}}$	20	V
Power dissipation	P_D	3.5 ($T_a = 25 \text{ deg. C}$)	W
		20 ($T_c = 25 \text{ deg. C}$)	
Junction temperature	T_j	150	deg. C
Operating temperature	T_{opg}	85	deg. C
Storage temperature range	T_{stg}	-20 to 110	deg. C

VPH05

Recommended Operating Conditions

T_a = 25 deg. C

Parameter	Symbol	Condition	Rating			Unit
			min	typ	max	
Supply voltage	V _{CC}	V _{out} = 100 V _{p-p} , V _{in(DC)} = 3.4 V	-	170	-	V
Bias voltage	V _{BB}		-	12	-	V
Supply voltage	V _{CC}	V _{out} = 120 V _{p-p} , V _{in(DC)} = 4.0 V	-	200	-	V
Bias voltage	V _{BB}		-	12	-	V

Electrical Characteristics

T_a = 25 deg. C

Parameter	Symbol	Condition	Rating			Unit
			min	typ	max	
Frequency bandwidth	f _c (-3 dB)	V _{out} = 100 V _{p-p} , V _{CC} = 170 V, V _{BB} = 12 V, V _{in(DC)} = 3.4 V	-	50	-	MHz
		V _{out} = 120 V _{p-p} , V _{CC} = 200 V, V _{BB} = 12 V, V _{in(DC)} = 4.0 V	-	45	-	
Voltage gain	G _v		26	29	32	
Current consumption	I _{CC}	f = 10 MHz, V _{CC} = 170 V, V _{BB} = 12 V	-	60	-	mA
		f = 50 MHz, V _{CC} = 170 V, V _{BB} = 12 V	-	100	-	
		f = 10 MHz, V _{CC} = 200 V, V _{BB} = 12 V	-	76	-	
		f = 50 MHz, V _{CC} = 200 V, V _{BB} = 12 V	-	96	-	

Measurement Circuit

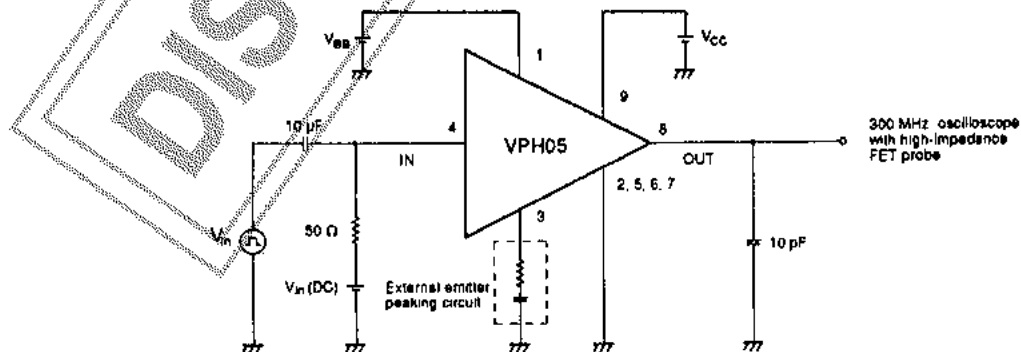

Typical Performance Characteristics

Output voltage vs. frequency

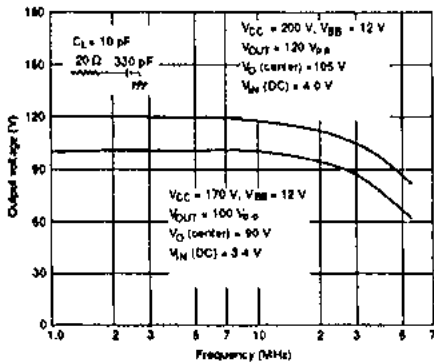

Supply current vs. input voltage

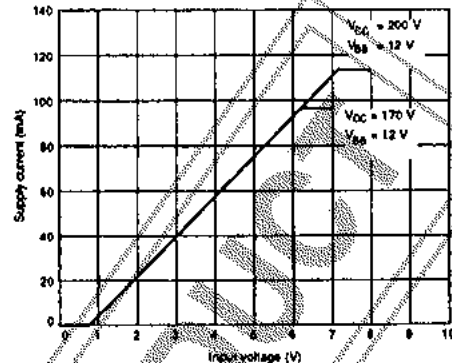

Supply current vs. frequency

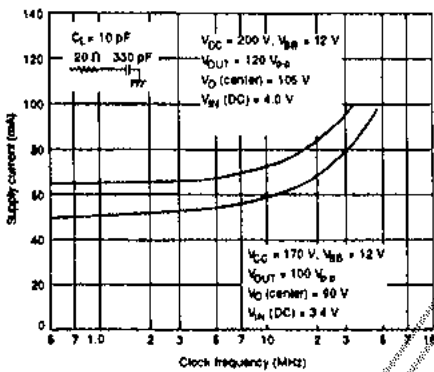

Power dissipation vs. ambient temperature

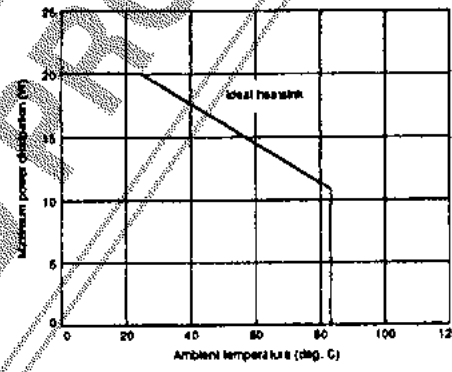

Output voltage vs. DC Input voltage

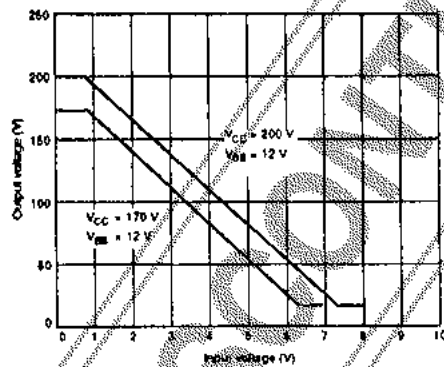

HEATSINK DESIGN

The transistor junction temperature should be kept below 150 deg. C. To achieve this, heatsinks should be designed to keep the case temperature below 80 deg. C. Note that the quantity of heat dissipated is proportional to the operating frequency. Thermal calculations should be carried out using the thermal dissipation specified at 30 MHz. Transistor TR2 generates the most heat—24% of the total dissipation—and is used in the following heatsink design calculations.

The transistor junction temperature, T_j , is calculated using the following equation.

$$T_j = (\theta_{j-c} \times P_c) + \Delta T_c + T_a \text{ (deg. C)}$$

where the symbols are defined as follows.

- θ_{j-c} Junction-to-case thermal resistance
- P_c Collector loss of the transistor
- ΔT_c Case temperature rise
- T_a Ambient temperature
- θ_h Heatsink thermal resistance

The junction-to-case thermal resistance, θ_{j-c} , is 30 deg. C/W for of transistor TR1, and 20 deg. C/W for transistors TR2 to TR4.

The collector loss, P_c , of each transistor is calculated using the following equation.

$$P_c = P_D \times \text{heat dissipation ratio}$$

The heat dissipation ratio for TR2 is 0.24.

The case temperature rise is calculated using the following equation.

$$\Delta T_c = P_D \times \theta_h$$

Power dissipation vs. signal frequency is shown in figure 1, and collector loss vs. frequency, in figure 2.

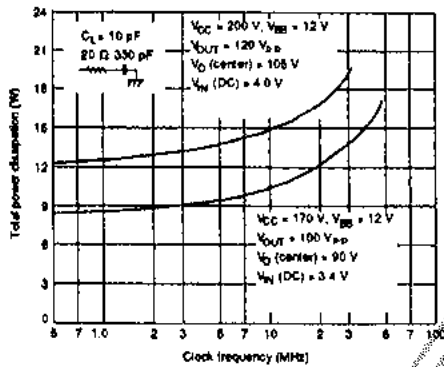

Figure 1. Power dissipation vs. signal frequency

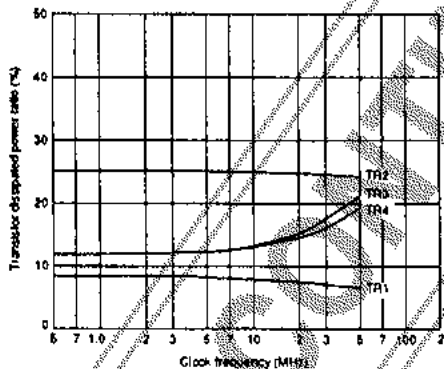

Figure 2. Collector loss vs. signal frequency

PRECAUTIONS

- Pins should not be short-circuited while power is applied.
- Correct heatsinking should be used to keep the case temperature below 80 deg. C.
- Note that the case is connected to ground.
- The recommended mounting torque is 4 to 6 kg/cm.

Sample Calculations

Example 1

This calculation uses the following conditions.

- Signal frequency = 30 MHz
- $V_{CC} = 170 V$
- $V_{BB} = 12 V$
- $V_{out} = 100 V_{p-p}$
- $C_L = 10 pF$
- $T_a = 60 \text{ deg. } C$

TR2 collector loss

$$P_c = P_D \times \text{heat dissipation ratio}$$

$$= 13.6 \times 0.24$$

$$= 3.26 W$$

P_D is read from figure 1.

Case temperature rise

$$T_j = (\theta_{j-c} \times P_c) + \Delta T_c + T_a$$

$$\Delta T_c = T_j - T_a - (\theta_{j-c} \times P_c)$$

$$= 150 - 60 - (20 \times 3.26)$$

$$= 24.8 \text{ deg. } C$$

Heatsink thermal resistance

$$\Delta T_c = P_D \times \theta_h$$

$$\theta_h = \Delta T_c + P_D$$

$$= 24.8 + 13.6$$

$$= 1.8 \text{ deg. } C/W$$

Heatsink thermal resistance should be less than 1.8 deg. C/W.

Example 2

The conditions are identical to those in example 1 except for the following.

- $T_a \leq 40 \text{ deg. } C$

The thermal resistance of the heatsink, θ_h , is calculated to be 3.3 deg. C/W by using the steps given in example 1. However, the heatsink should have a thermal resistance less than this value.

Information (including circuit diagrams and circuit parameters) herein is for example only; it is not guaranteed for volume production. SANYO believes information herein is accurate and reliable, but no guarantees are made or implied regarding its use or any infringements of intellectual property rights or other rights of third parties.