

# Dual asynchronous receiver/transmitter (DUART)

# SCN2681T

## DESCRIPTION

The Signetics SCN2681 Dual Universal Asynchronous Receiver/Transmitter (DUART) is a single-chip MOS-LSI communications device that provides two independent full-duplex asynchronous receiver/transmitter channels in a single package. The SCN2681T features a faster bus cycle time than the standard SCN2681. The quick bus cycle eliminates or reduces the need for wait states with fast CPUs and permits high throughput in I/O intensive systems. Higher external clock rates may be used with the transmitter, receiver and counter timer which in turn provide greater versatility in baud rate generation. The SCN2681T interfaces directly with microprocessors and may be used in a polled or interrupt driven system.

The operating mode and data format of each channel can be programmed independently. Additionally, each receiver and transmitter can select its operating speed as one of eighteen fixed baud rates, a 16X clock derived from a programmable counter/timer, or an external 1X or 16X clock. The baud rate generator and counter/timer can operate directly from a crystal or from external clock inputs. The ability to independently program the operating speed of the receiver and transmitter make the DUART particularly attractive for dual-speed channel applications such as clustered terminal systems.

Each receiver is quadruple buffered to minimize the potential of receiver over-run or to reduce interrupt overhead in interrupt driven systems. In addition, a flow control capability is provided to disable a remote DUART transmitter when the receiver buffer is full.

Also provided on the SCN2681T are a multipurpose 7-bit input port and a multipurpose 8-bit output port. These can be used as general purpose I/O ports or can be assigned specific functions (such as clock inputs or status/interrupt outputs) under program control.

For a complete functional description and programming information for the SCN2681T, refer to the SCN2681 product specification.

## FEATURES

- Fast bus cycle times reduce or eliminate CPU wait states
- Dual full-duplex asynchronous receiver/transmitters
- Quadruple buffered receiver data registers
- Programmable data format
  - 5 to 8 data bits plus parity
  - Odd, even, no parity or force parity
  - 1, 1.5 or 2 stop bits programmable in 1/16-bit increments
- Programmable baud rate for each receiver and transmitter selectable from:
  - 18 fixed rates: 50 to 38.4k baud
  - Non-standard rates to 115.2
  - One user-defined rate derived from programmable counter/timer
  - External 1X or 16X clock
- Parity, framing, and overrun error detection
- False start bit detection
- Line break detection and generation
- Programmable channel mode

- Normal (full-duplex)
- Automatic echo
- Local loopback
- Remote loopback
- Multi-function programmable 16-bit counter/timer
- Multi-function 7-bit input port
  - Can serve as clock or control inputs
  - Change of state detection on four inputs
- Multi-function 8-bit output port
  - Individual bit set/reset capability
  - Outputs can be programmed to be status/interrupt signals
- Versatile interrupt system
  - Single interrupt output with eight maskable interrupting conditions
  - Output port can be configured to provide a total of up to six separate wire-ORable interrupt outputs
- Maximum data transfer rates:
  - 1X – 1MB/sec transmitter and receiver;
  - 16X – 500kB/sec receiver and 250kB/sec transmitter
- Automatic wake-up mode for multidrop applications
- Start-end break interrupt/status
- Detects break which originates in the middle of a character
- On-chip crystal oscillator
- Single +5V power supply
- Commercial and industrial temperature ranges available

## ORDERING INFORMATION

DESCRIPTION	$V_{CC} = +5V \pm 10\%$ , $T_A = 0^\circ C$ to $+70^\circ C$
40-Pin Plastic DIP (600mil-wide DIP)	SCN2681TC1N40A
44-Pin Plastic LCC	SCN2681TC1A44A

NOTE: For a full register description and programming information see the SCN2681.

# Dual asynchronous receiver/transmitter (DUART)

# SCN2681T

## PIN CONFIGURATIONS

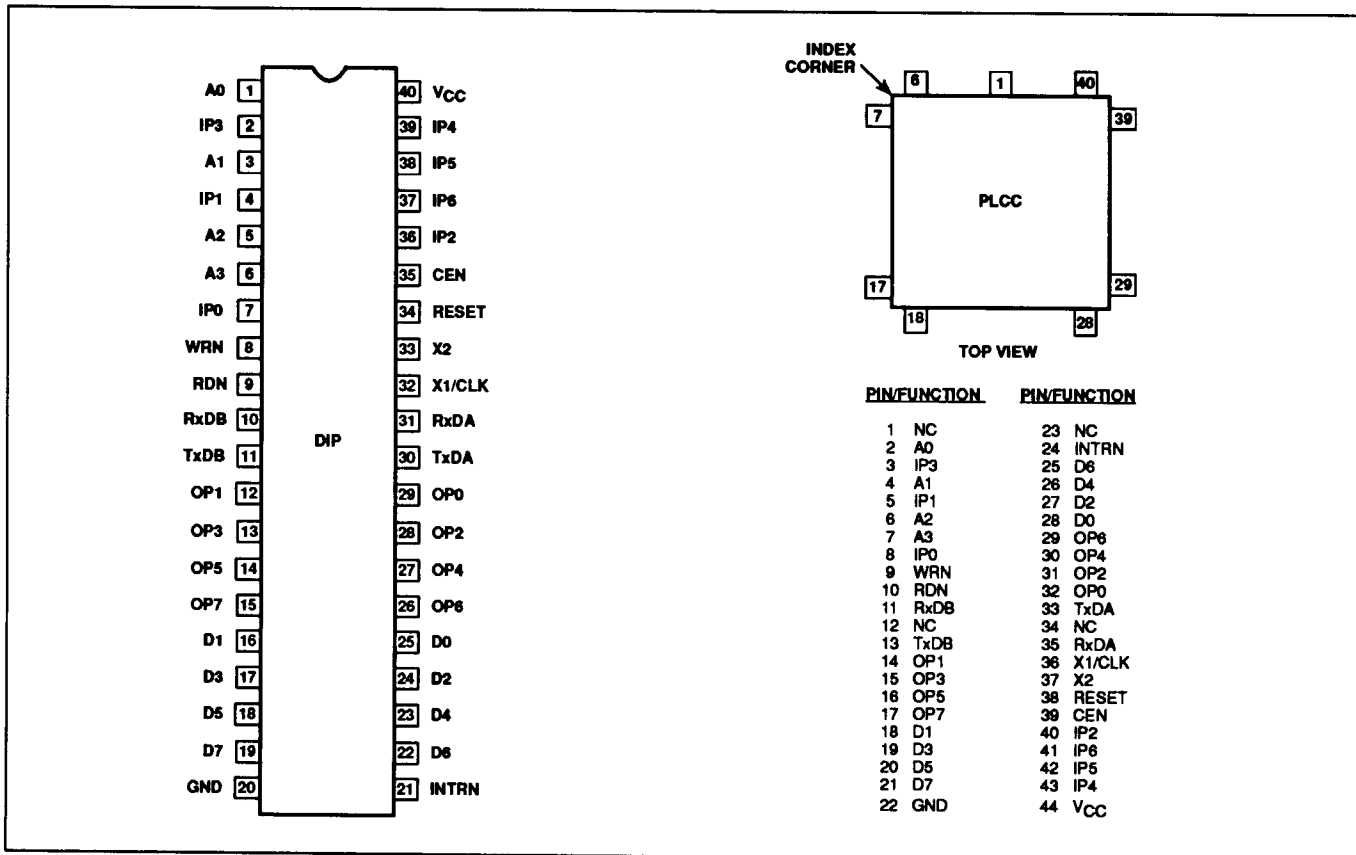

# Dual asynchronous receiver/transmitter (DUART)

SCN2681T

## BLOCK DIAGRAM

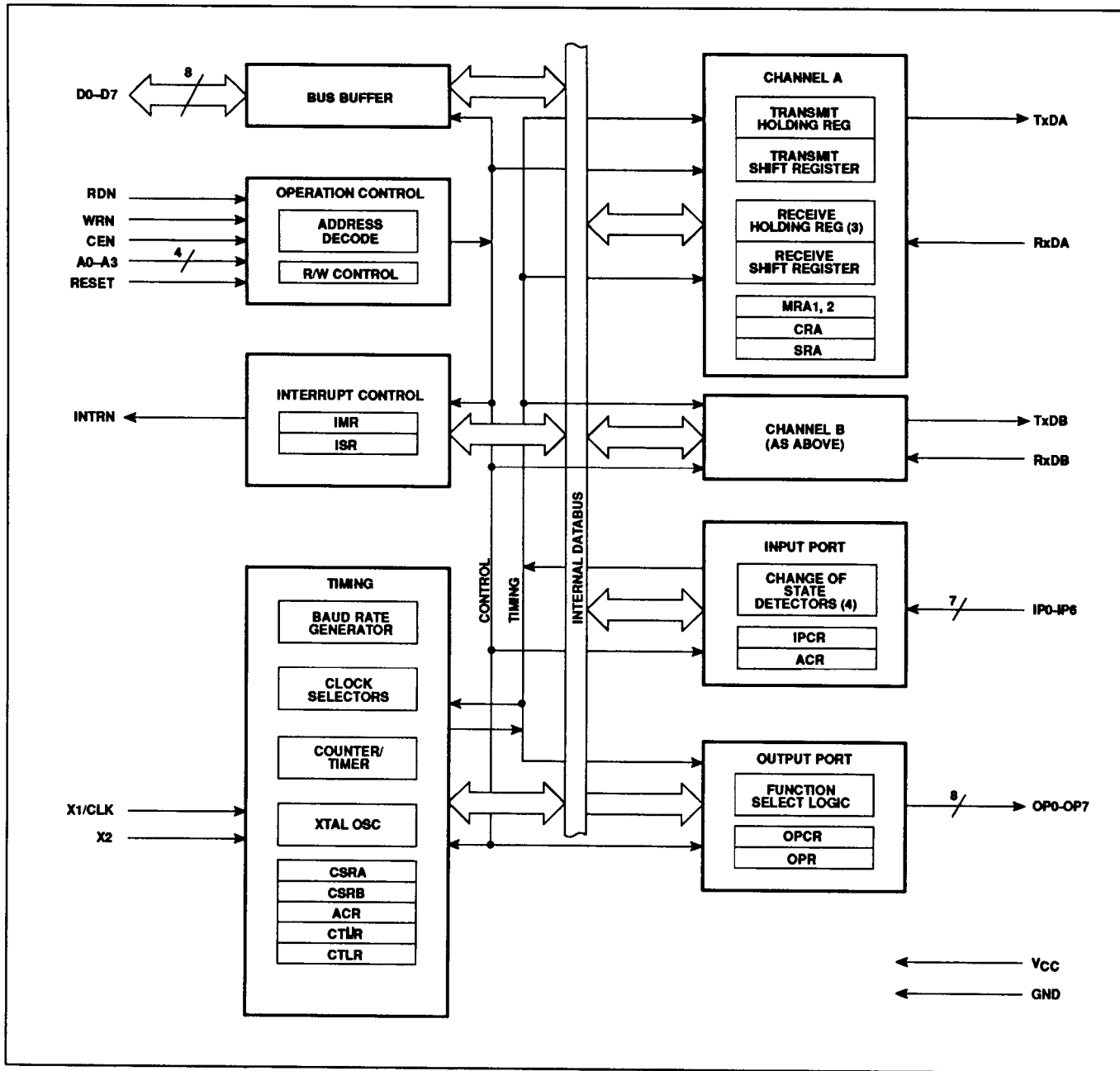

## Dual asynchronous receiver/transmitter (DUART)

SCN2681T

## PIN DESCRIPTION

MNEMONIC	TYPE	NAME AND FUNCTION
D0–D7	I/O	<b>Data Bus:</b> Bidirectional three-state data bus used to transfer commands, data and status between the DUART and the CPU. D0 is the least significant bit.
CEN	I	<b>Chip Enable:</b> Active low input signal. When low, data transfers between the CPU and the DUART are enabled on D0–D7 as controlled by the WRN, RDN, and A0–A3 inputs. When CEN is high, the DUART places the D0–D7 lines in the three-state condition.
WRN	I	<b>Write Strobe:</b> When low and CEN is also low, the contents of the data bus is loaded into the addressed register. The transfer occurs on the rising edge of the signal.
RDN	I	<b>Read Strobe:</b> When low and CEN is also low, causes the contents of the addressed register to be presented on the data bus. The read cycle begins on the falling edge of RDN.
A0–A3	I	<b>Address Inputs:</b> Select the DUART internal registers and ports for read/write operations.
RESET	I	<b>Reset:</b> A high level clears internal registers (SRA, SRB, IMR, ISR, OPR, OPCR), puts OP0–OP7 in the high state, stops the counter/timer, and puts channels A and B in the inactive state, with the TxDA and TxDB outputs in the mark (high) state. Clears Test modes.
INTRN	O	<b>Interrupt Request:</b> Active-low, open-drain output which signals the CPU that one or more of the eight maskable interrupting conditions are true.
X1/CLK	I	<b>Crystal 1:</b> Crystal or external clock input. A crystal or clock of the specified limits must be supplied at all times. When a crystal is used, a capacitor must be connected from this pin to ground (see Figure 5).
X2	I	<b>Crystal 2:</b> Connection for other side of crystal. When a crystal is used, a capacitor must be connected from this pin to ground (see Figure 5). If X1/CLK is driven from an external source, this pin should be grounded.
RxDA	I	<b>Channel A Receiver Serial Data Input:</b> The least significant bit is received first. 'Mark' is high, 'space' is low.
RxDB	I	<b>Channel B Receiver Serial Data Input:</b> The least significant bit is received first. 'Mark' is high, 'space' is low.
TxDA	O	<b>Channel A Transmitter Serial Data Output:</b> The least significant bit is transmitted first. This output is held in the 'mark' condition when the transmitter is disabled, idle, or when operating in local loopback mode. 'Mark' is high, 'space' is low.
TxDB	O	<b>Channel B Transmitter Serial Data Output:</b> The least significant bit is transmitted first. This output is held in the 'mark' condition when the transmitter is disabled, idle, or when operating in local loopback mode. 'Mark' is high, 'space' is low.
OP0	O	<b>Output 0:</b> General purpose output, or channel A request to send (RTSAN, active-low). Can be deactivated automatically on receive or transmit.
OP1	O	<b>Output 1:</b> General purpose output, or channel B request to send (RTSBN, active-low). Can be deactivated automatically on receive or transmit.
OP2	O	<b>Output 2:</b> General purpose output, or channel A transmitter 1X or 16X clock output, or channel A receiver 1X clock output.
OP3	O	<b>Output 3:</b> General purpose output, or open-drain, active-low counter/timer output, or channel B transmitter 1X clock output, or channel B receiver 1X clock output.
OP4	O	<b>Output 4:</b> General purpose output, or channel A open-drain, active-low, RxRDYA/FFULLA output.
OP5	O	<b>Output 5:</b> General purpose output, or channel B open-drain, active-low, RxRDYB/FFULLB output.
OP6	O	<b>Output 6:</b> General purpose output, or channel A open-drain, active-low, TxRDYA output.
OP7	O	<b>Output 7:</b> General purpose output, or channel B open-drain, active-low TxRDYB output.
IP0	I	<b>Input 0:</b> General purpose input, or channel A clear to send active-low input (CTSAN).
IP1	I	<b>Input 1:</b> General purpose input, or channel B clear to send active-low input (CTSBN).
IP2	I	<b>Input 2:</b> General purpose input, or counter/timer external clock input.
IP3	I	<b>Input 3:</b> General purpose input, or channel A transmitter external clock input (TxCA). When the external clock is used by the transmitter, the transmitted data is clocked on the falling edge of the clock.
IP4	I	<b>Input 4:</b> General purpose input, or channel A receiver external clock input (RxCA). When the external clock is used by the receiver, the received data is sampled on the rising edge of the clock.

## Dual asynchronous receiver/transmitter (DUART)

SCN2681T

## PIN DESCRIPTION (Continued)

MNEMONIC	TYPE	NAME AND FUNCTION
IP5	I	<b>Input 5:</b> General purpose input, or channel B transmitter external clock input (TxCB). When the external clock is used by the transmitter, the transmitted data is clocked on the falling edge of the clock.
IP6	I	<b>Input 6:</b> General purpose input, or channel B receiver external clock input (RxCB). When the external clock is used by the receiver, the received data is sampled on the rising edge of the clock.
V <sub>CC</sub>	I	<b>Power Supply:</b> +5V supply input.
GND	I	<b>Ground</b>

ABSOLUTE MAXIMUM RATINGS<sup>1</sup>

SYMBOL	PARAMETER	RATING	UNIT
T <sub>A</sub>	Operating ambient temperature range <sup>2</sup>	0 to +70	°C
T <sub>STG</sub>	Storage temperature range	-65 to +150	°C
	All voltages with respect to GND <sup>3</sup>	-0.5 to +6.0	V

## NOTES:

- Stresses above those listed under Absolute Maximum Ratings may cause permanent damage to the device. This is a stress rating only and functional operation of the device at these or any other conditions above those indicated in the operation section of this specification is not implied.
- For operating at elevated temperatures, the device must be derated based on +150°C maximum junction temperature.
- This product includes circuitry specifically designed for the protection of its internal devices from damaging effects of excessive static charge. Nonetheless, it is suggested that conventional precautions be taken to avoid applying any voltages larger than the rated maxima.

DC ELECTRICAL CHARACTERISTICS<sup>1, 2, 3</sup>

SYMBOL	PARAMETER	TEST CONDITIONS	LIMITS			UNIT
			Min	Typ	Max	
V <sub>IL</sub>	Input low voltage				0.8	V
V <sub>IH</sub>	Input high voltage (except X1/CLK)		2.0			V
V <sub>IH</sub>	Input high voltage (X1/CLK)		3.5			V
V <sub>OL</sub>	Output low voltage	I <sub>OL</sub> = 2.4mA				V
V <sub>OH</sub>	Output high voltage (except o.c. outputs) <sup>4</sup>	I <sub>OH</sub> = -400µA	2.4		0.4	V
I <sub>IL</sub>	Input leakage current	V <sub>IN</sub> = 0 to V <sub>CC</sub>	-10		10	µA
I <sub>LL</sub>	Data bus 3-state leakage current	V <sub>O</sub> = 0.4 to V <sub>CC</sub>	-10		10	µA
I <sub>X1L</sub>	X1/CLK low input current	V <sub>IN</sub> = 0, X2 grounded	-4	-2	0	mA
I <sub>X1H</sub>	X1/CLK high input current	V <sub>IN</sub> = 0, X2 floated	-3	-1.5	0	mA
I <sub>X2L</sub>	X2 low input current	V <sub>IN</sub> = V <sub>CC</sub> , X2 = grounded	-1	0.2	1	mA
I <sub>X2H</sub>	X2 high input current	V <sub>IN</sub> = V <sub>CC</sub> , X2 floated	0	3.5	10	mA
I <sub>oc</sub>	Open-collector output leakage current	V <sub>IN</sub> = 0, X1/CLK floated	-100	-30	0	µA
I <sub>cc</sub>	Power supply current <sup>5</sup>	V <sub>IN</sub> = V <sub>CC</sub> , X1/CLK floated	0	+30	100	µA
I <sub>CC</sub>	Power supply current <sup>5</sup>	V <sub>O</sub> = 0.4 to V <sub>CC</sub>	-10		10	µA
I <sub>CC</sub>	Power supply current <sup>5</sup>	0°C to +70°C version			150	mA

## NOTES:

- Parameters are valid over specified temperature range. See Ordering information table for applicable operating temperature range and V<sub>CC</sub> supply range.
- All voltage measurements are referenced to ground (GND). For testing, all inputs except X1/CLK swing between 0.4V and 2.4V with a transition time of 20ns maximum. For X1/CLK this swing is between 0.4V and 4.0V. All time measurements are referenced at input voltages of 0.8V and 2.0V and output voltages of 0.8V and 2.0V as appropriate.
- Typical values are at +25°C, typical supply voltages, and typical processing parameters.
- Test conditions for outputs: C<sub>L</sub> = 150pF, except interrupt outputs. Test conditions for interrupt outputs: C<sub>L</sub> = 50pF, R<sub>L</sub> = 2.7kΩ to V<sub>CC</sub>.
- For bus operations, CEN and RDN (also CEN and WRN) are ANDed internally. As a consequence, the signal asserted last initiates the cycle and the signal negated first terminates the cycle.

## Dual asynchronous receiver/transmitter (DUART)

SCN2681T

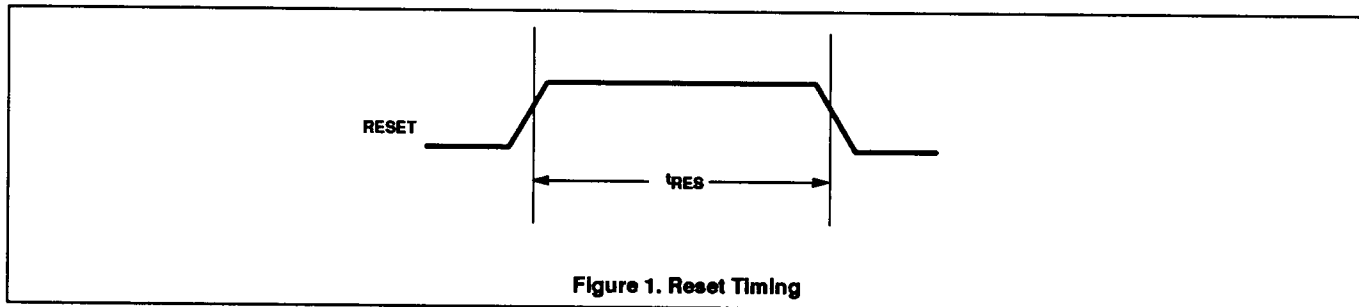
AC ELECTRICAL CHARACTERISTICS<sup>1, 2, 3, 4</sup>**NOTES:**

1. Parameters are valid over specified temperature range. See Ordering information table for applicable operating temperature range and  $V_{CC}$  supply range.
2. All voltage measurements are referenced to ground (GND). For testing, all inputs except X1/CLK swing between 0.4V and 2.4V with a transition time of 20ns maximum. For X1/CLK this swing is between 0.4V and 4.0V. All time measurements are referenced at input voltages of 0.8V and 2.0V and output voltages of 0.8V and 2.0V as appropriate.
3. Typical values are at +25°C, typical supply voltages, and typical processing parameters.
4. Test conditions for outputs:  $C_L = 150\text{pF}$ , except interrupt outputs. Test conditions for interrupt outputs:  $C_L = 50\text{pF}$ ,  $R_L = 2.7\text{k}\Omega$  to  $V_{CC}$ .

SYMBOL	PARAMETER	LIMITS		UNIT
		Min	Max	
$t_{RES}$	Reset pulse width	1.0		$\mu\text{s}$

# Dual asynchronous receiver/transmitter (DUART)

SCN2681T

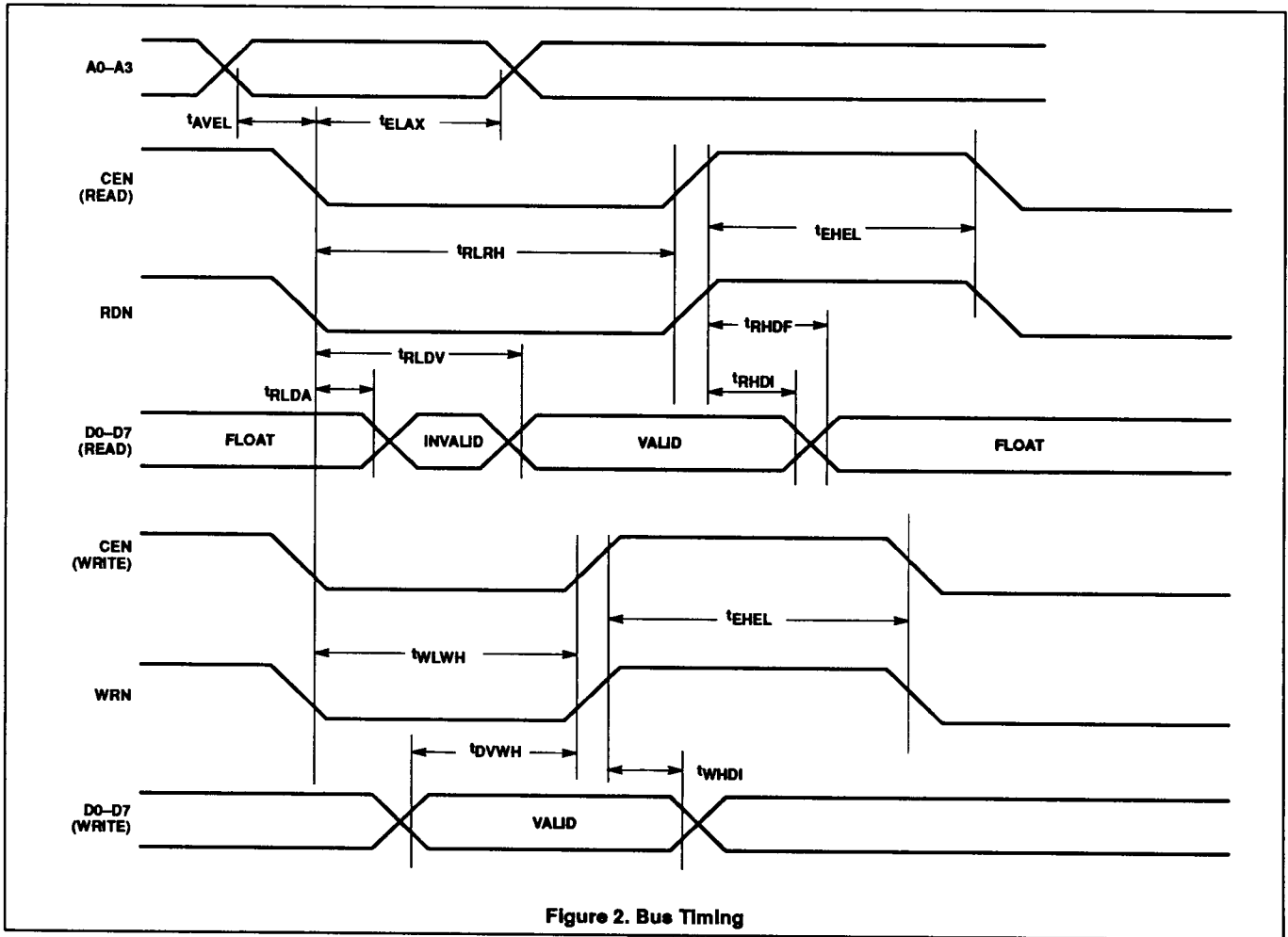

Figure 2. Bus Timing

SYMBOL	PARAMETER <sup>1</sup>	LIMITS		UNIT
		Min	Max	
$t_{AVEL}$	A0-A3 setup to RDN and CEN, or WRN and CEN low	0		ns
$t_{ELAX}$	RDN and CEN, or WRN and CEN low to A0-A3 invalid	100		ns
$t_{RLRH}$	RDN and CEN low to RDN or CEN high	120		ns
$t_{EHEL}$	CEN high to CEN low <sup>2, 3</sup>	110		ns
$t_{RLDA}$	CEN and RDN low to data outputs active	15		ns
$t_{RLDV}$	CEN and RDN low to data valid		100	ns
$t_{RHDI}$	CEN or RDN high to data invalid	10		ns
$t_{RHDF}$	CEN or RDN high to data outputs floating		65	ns
$t_{WLWH}$	WRN and CEN low to WRN or CEN high	75		ns
$t_{DVWH}$	Data input valid to WRN or CEN high	35		ns
$t_{WHDI}$	WRN or CEN high to data invalid	15		ns

**NOTES:**

1. For bus operations, CEN and RDN (also CEN and WRN) are ANDed internally. As a consequence, the signal asserted last initiates the cycle and the signal negated first terminates the cycle.
2. If CEN is used as the 'strobing' input, the parameter defines the minimum high times between one CEN and the next. The RDN signal must be negated for  $t_{EHEL}$  to guarantee that any status register changes are valid. As a consequence, this minimum time must be met for the RDN input even if the CEN is used as the strobing signal for bus operations.
3. Consecutive write operations to the same command register require at least three edges of the X1 clock between writes.

# Dual asynchronous receiver/transmitter (DUART)

SCN2681T

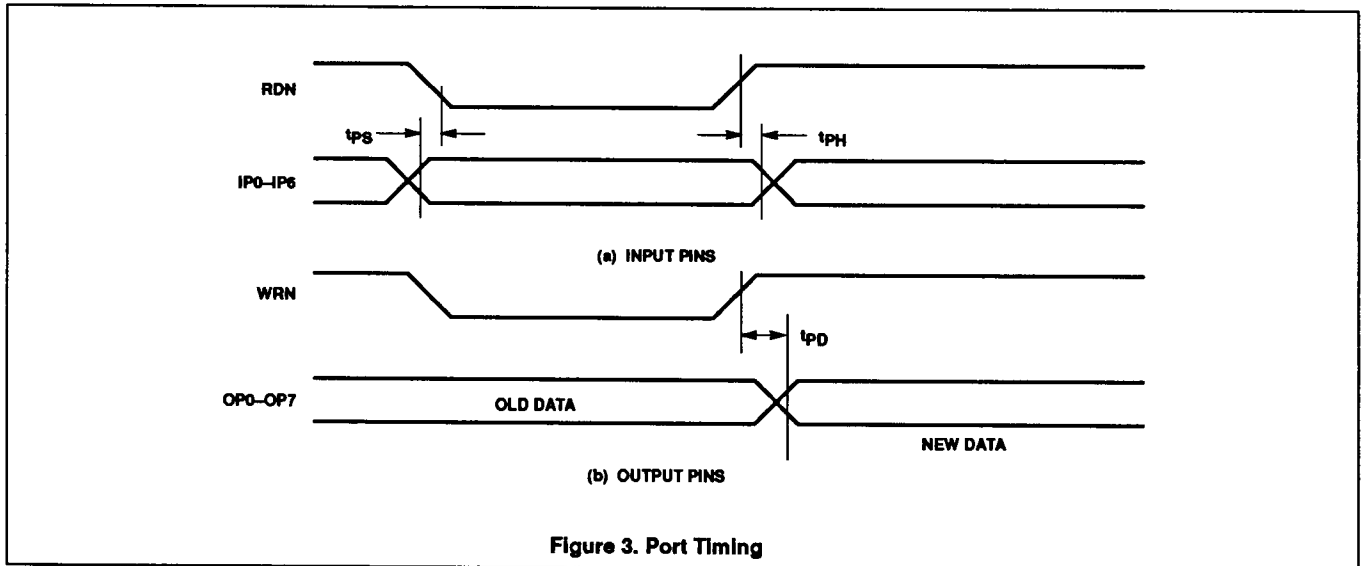

Figure 3. Port Timing

SYMBOL	PARAMETER <sup>1</sup>	LIMITS		UNIT
		Min	Max	
$t_{PS}$	Port input setup time before RDN low	0		ns
$t_{PH}$	Port input hold time after RDN high	0		ns
$t_{PD}$	Port output valid after WRN high		200	ns

**NOTE:**

- For bus operations, CEN and RDN (also CEN and WRN) are ANDed internally. As a consequence, the signal asserted last initiates the cycle and the signal negated first terminates the cycle.

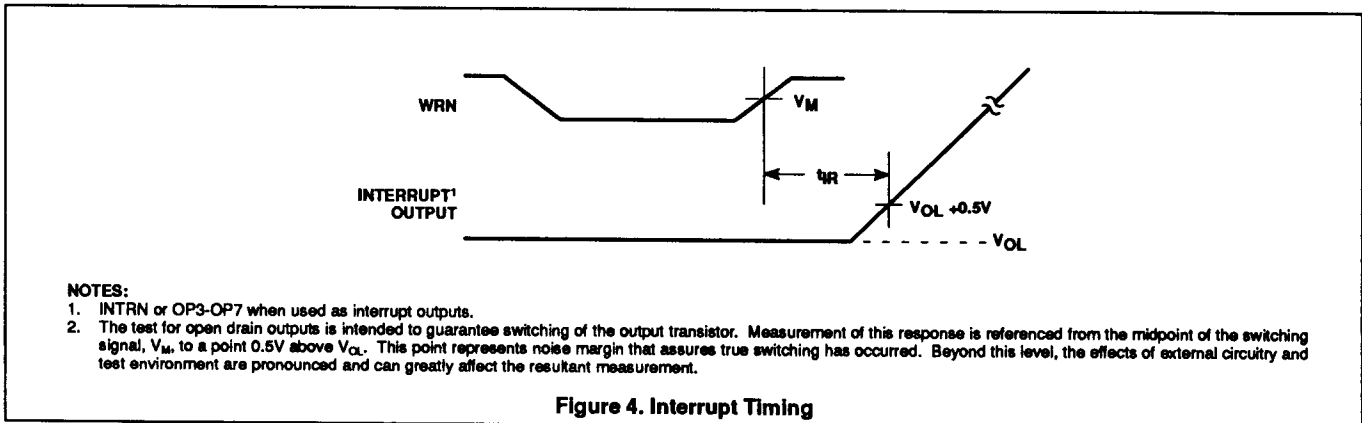

Figure 4. Interrupt Timing

**NOTES:**

- INTRN or OP3-OP7 when used as interrupt outputs.
- The test for open drain outputs is intended to guarantee switching of the output transistor. Measurement of this response is referenced from the midpoint of the switching signal,  $V_M$ , to a point 0.5V above  $V_{OL}$ . This point represents noise margin that assures true switching has occurred. Beyond this level, the effects of external circuitry and test environment are pronounced and can greatly affect the resultant measurement.

SYMBOL	PARAMETER	LIMITS		UNIT
		Min	Max	
$t_{IR}$	INTRN (or OP3-OP7 when used as interrupts) negated from: Read RHR (RxRDY/FFULL interrupt) Write THR (TxRDY interrupt) Reset command (delta break interrupt) Stop C/T command (counter interrupt) Read IPCR (input port change interrupt) Write IMR (clear of interrupt mask bit)		200	ns
			200	ns
			200	ns
			200	ns
			200	ns
			200	ns

# Dual asynchronous receiver/transmitter (DUART)

## SCN2681T

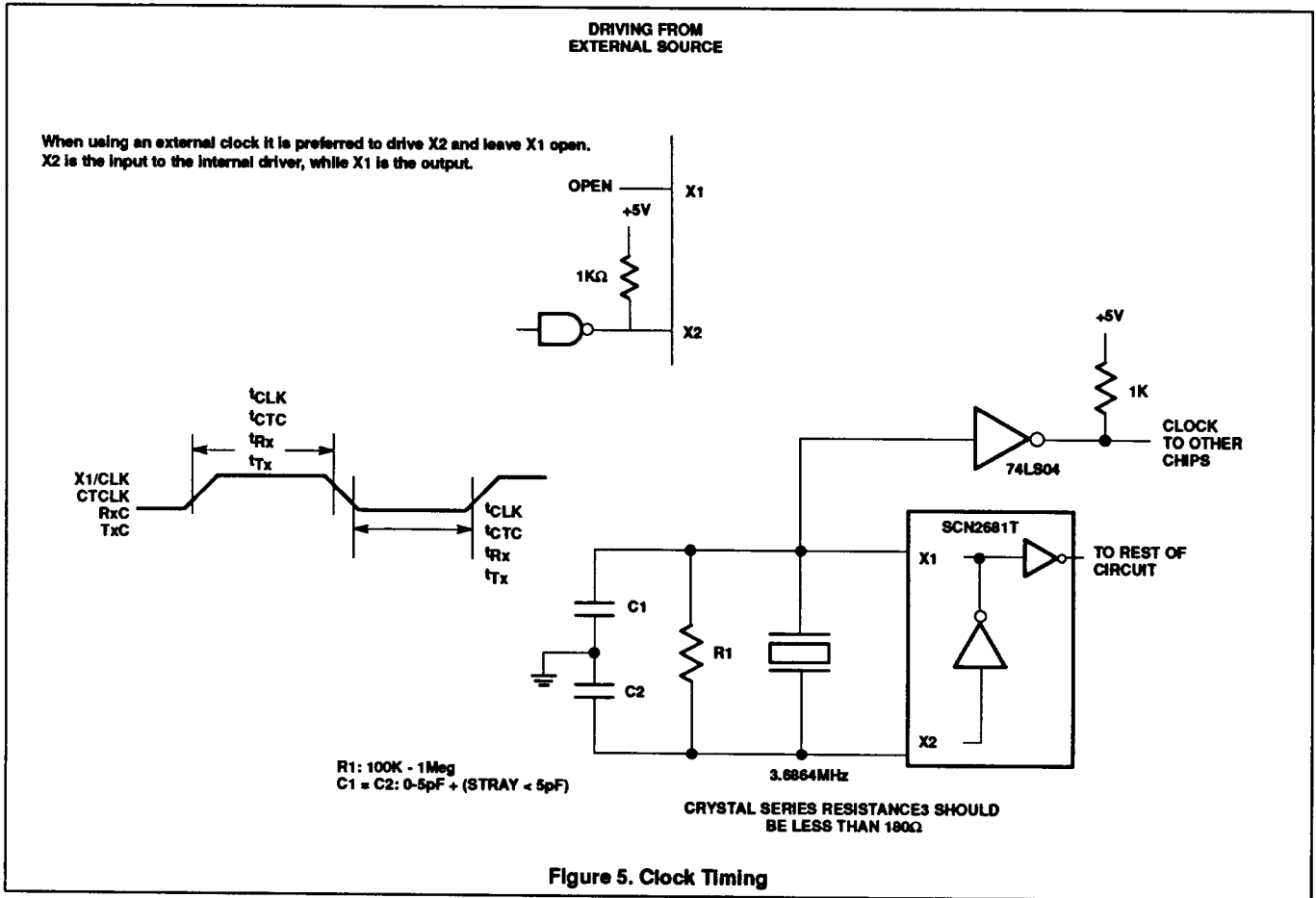

SYMBOL	PARAMETER	LIMITS			UNIT
		Min	Typ	Max	
t <sub>CLK</sub>	X1/CLK high or low time	90			ns
f <sub>CLK</sub>	X1/CLK frequency	2	3.686	4	MHz
t <sub>CTC</sub>	CTCLK (IP2) high or low time	55	4		ns
f <sub>CTC</sub>	CTCLK (IP2) frequency <sup>1</sup>	0		8	MHz
t <sub>RX</sub>	RxC high or low time	55			ns
f <sub>RX</sub>	RxC frequency (16X) <sup>1</sup>	0		8	MHz
t <sub>TX</sub>	TxC high or low time (1X) <sup>1</sup>	0		1	MHz
f <sub>TX</sub>	TxC frequency (16X) <sup>1</sup>	110			ns
		0		4	MHz
		0		1	MHz

**NOTE:**

1. Minimum frequencies are not tested but are guaranteed by design.

# Dual asynchronous receiver/transmitter (DUART)

SCN2681T

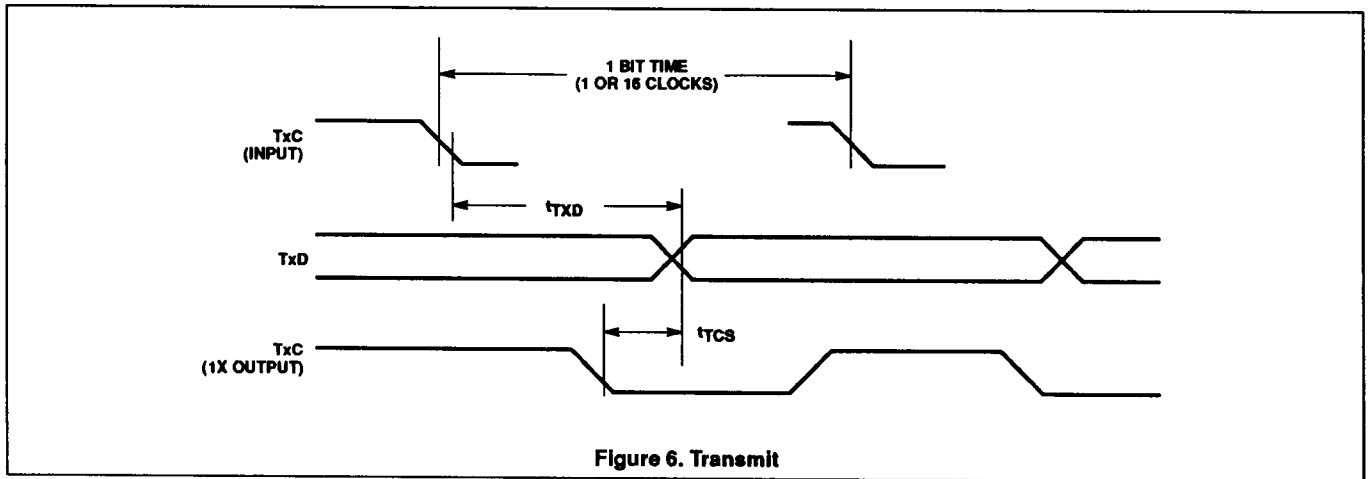

Figure 6. Transmit

SYMBOL	PARAMETER	LIMITS		UNIT
		Min	Max	
$t_{TXD}$	TxD output delay from TxC low	0	300	ns
$t_{TCS}$	Output delay from TxC low to TxD data output	0	100	ns

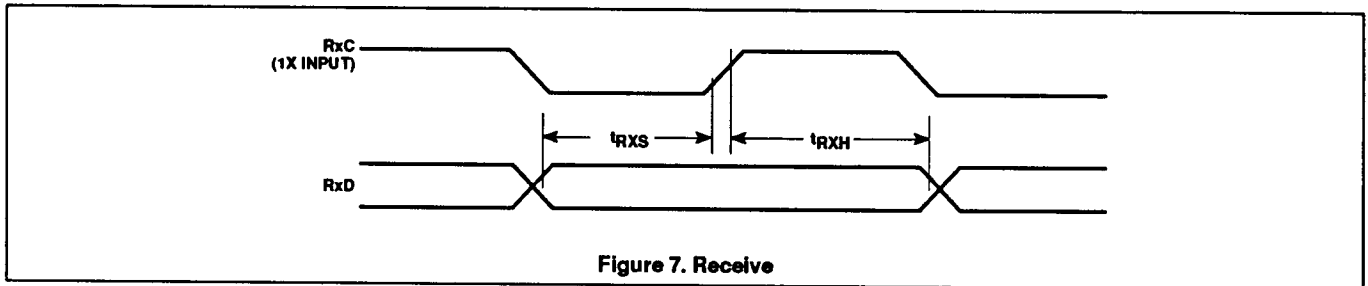

Figure 7. Receive

SYMBOL	PARAMETER	LIMITS		UNIT
		Min	Max	
$t_{RXS}$	RxD data setup time to RxC high	200		ns
$t_{RXH}$	RxD data hold time from RxC high	25		ns

# Dual asynchronous receiver/transmitter (DUART)

SCN2681T

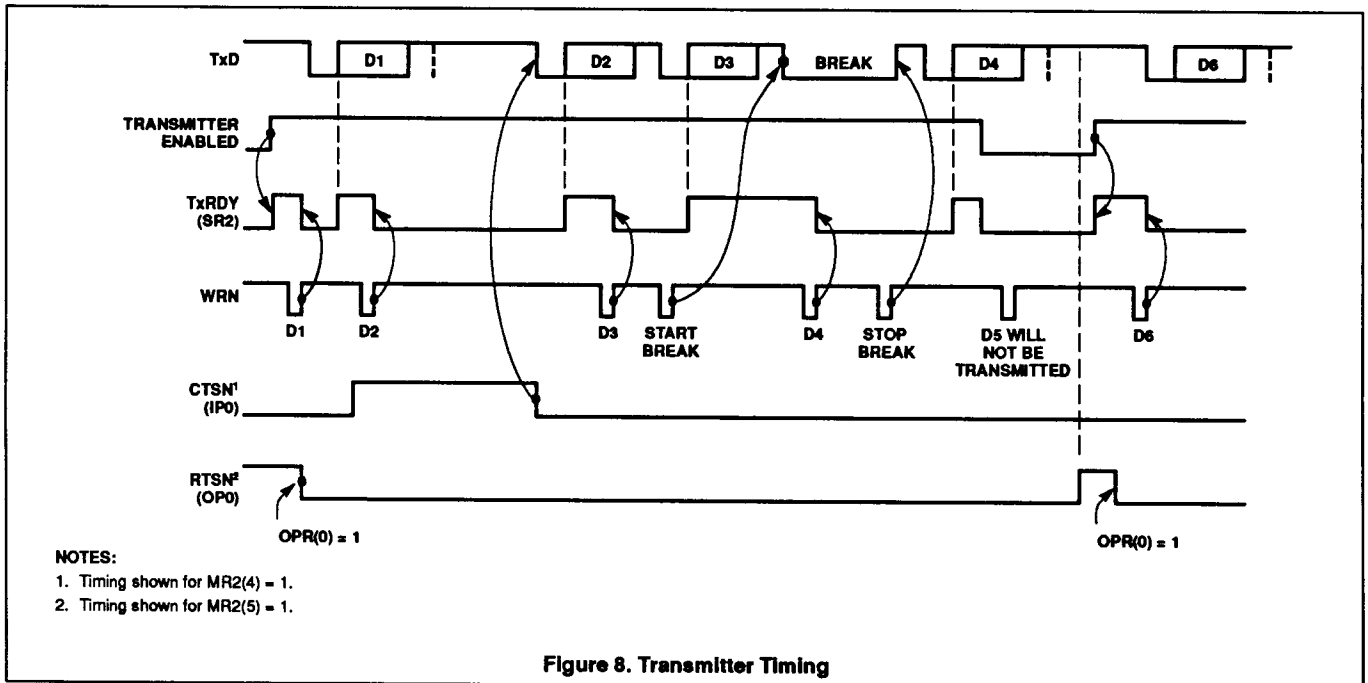

Figure 8. Transmitter Timing

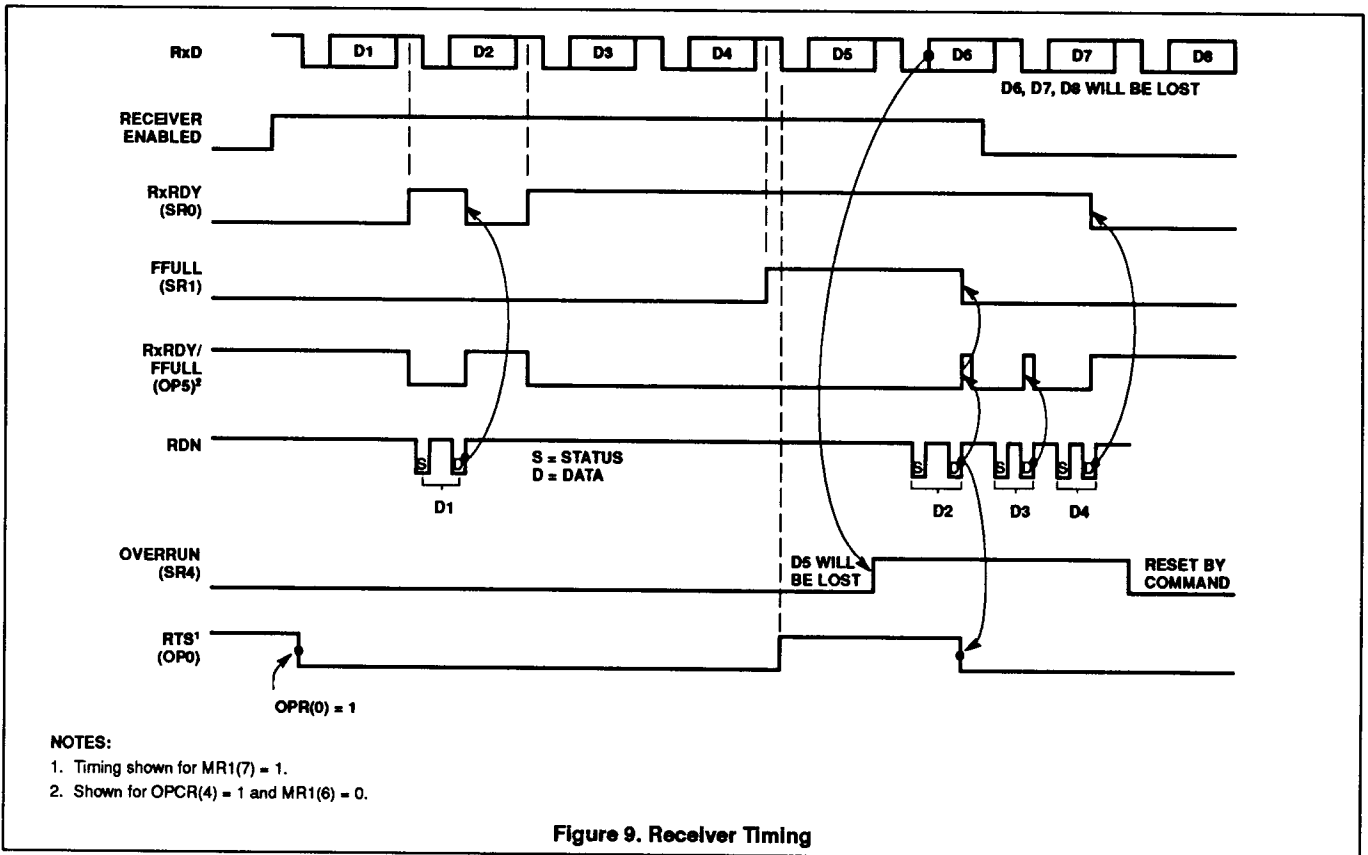

Figure 9. Receiver Timing

# Dual asynchronous receiver/transmitter (DUART)

SCN2681T

