

AN7194K, AN7194Z

Dual BTL 50 W single power supply class-H power amplifier IC

■ Overview

The AN7194K and AN7194Z are single power supply, BTL, audio class-H power amplifier ICs. A class-H power amplifier can be made up when this ICs are used in combination with the AN7077Z which is separately market-available, and it is possible to make a low consumption power system. Also, the AN7194K and AN7194Z are incorporating various protection circuits, so that those ICs contribute to the high reliability design of set.

■ Features

- Incorporating various protection circuits :
Thermal protection, load short-circuit, short circuit to V_{CC} and short circuit to GND, overvoltage.
- Built-in stand-by function
(Free from shock noise when standby turns-on/off)
- Built-in muting function
Free from shock noise at mute-on/off
Adapting attenuator method so that abnormal sound is not generated due to waveform deformation
Attack time, recovery time are 20 ms or less
- Reduction in external components
NF and BS electrolytic capacitors are needless
RF electrolytic capacitor is needless
External muting function is needless
- OR output terminal is provided
- Designed for headphone use
- The AN7194K is of a 16-pin and the AN7194Z is of a 15-pin package

■ Applications

- Miniature audio component, CD player radio cassette, karaoke are other audio equipment

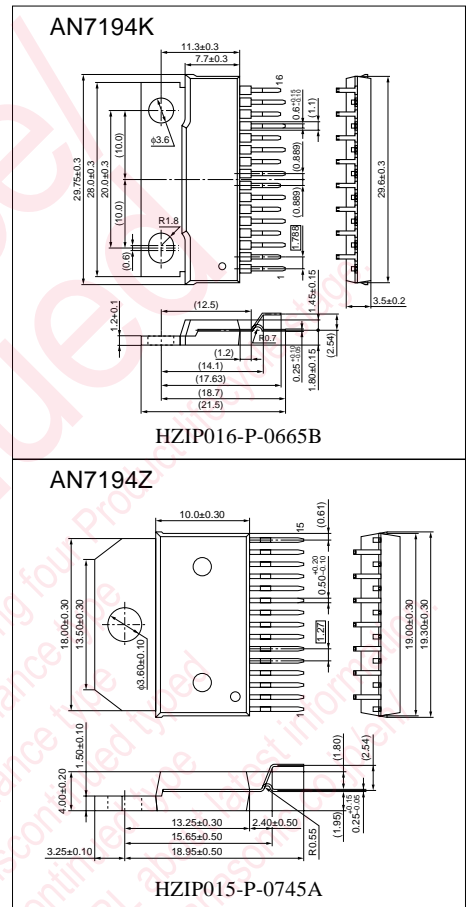

■ Block Diagram

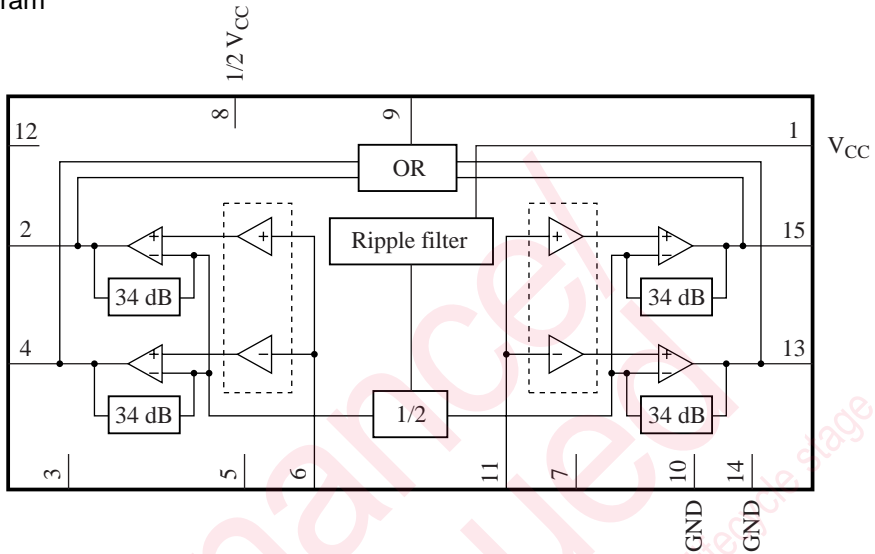

■ Pin Descriptions

Pin No.	Description	Pin No.	Description
1	Power supply	9	OR output
2	Ch.1 output (-)	10	GND
3	Grounding (output ch.1)	11	Ch.2 input
4	Ch.1 output (+)	12	N.C.
5	Stand-by	13	Ch.2 output (+)
6	Ch.1 input	14	Grounding (output ch.2)
7	Muting	15	Ch.2 output (-)
8	Middle point (1/2 V _{CC})	16	N.C. (for the AN7194K only)

■ Absolute Maximum Ratings

Parameter	Symbol	Rating	Unit
Supply voltage	V _{CC}	26	V
Supply current	I _{CC}	9.0	A
Power dissipation *2	P _D	AN7194K	W
		AN7194Z	
Operating ambient temperature *1	T _{opr}	-25 to +75	°C
Storage temperature *1	T _{stg}	-55 to +150	°C

Note) *1 : All items are at T_a = 25°C, except for the operating ambient temperature and storage temperature.

*2 : The value when R_{th(j-c)} = 1.1°C/W, and T_a = 75°C

■ Recommended Operating Range

Parameter	Symbol	Range	Unit
Supply voltage	V _{CC}	6.0 to 24.0	V

■ Electrical Characteristics at $V_{CC} = 12\text{ V}$, $f = 1\text{ kHz}$, $T_a = 25^\circ\text{C}$

Parameter	Symbol	Conditions	Min	Typ	Max	Unit
Quiescent current	I_{CQ}	$V_{IN} = 0\text{ mV}$, $R_L = 6\ \Omega$	—	150	250	mA
Standby current	I_{STB}	$V_{IN} = 0\text{ mV}$, $R_L = 6\ \Omega$	—	1	10	μA
Output noise voltage ^{*1}	V_{NO}	$R_G = 10\text{ k}\Omega$, $R_L = 6\ \Omega$	—	0.22	0.5	mV[rms]
Voltage gain	G_V	$V_{IN} = 24.5\text{ mV}$, $R_L = 6\ \Omega$	38	40	42	dB
Total harmonics distortion	THD	$V_{IN} = 24.5\text{ mV}$, $R_L = 6\ \Omega$	—	0.2	0.6	%
Maximum output power 1	P_{O1}	THD = 10%, $R_L = 6\ \Omega$	8	10	—	W
Maximum output power 2 ^{*2}	P_{O2}	THD = 10%, $R_L = 6\ \Omega$	30	44	—	W
Ripple rejection ratio ^{*1}	RR	$R_L = 6\ \Omega$, $R_G = 10\text{ k}\Omega$ $V_R = 1\text{ V[rms]}$, $f_R = 1\text{ kHz}$	45	60	—	dB
Channel balance ^{*1}	CB	$V_{IN} = 24.5\text{ mV}$, $R_L = 6\ \Omega$	-1	0	1	dB
Cross-talk ^{*1}	CT	$V_{IN} = 24.5\text{ mV}$, $R_L = 6\ \Omega$, $R_G = 10\text{ k}\Omega$	50	60	—	dB
Output offset voltage	V_{OFF}	$R_G = 10\text{ k}\Omega$, $R_L = 6\ \Omega$	-300	0	300	mV
Muting effect ^{*1}	MT	$V_{IN} = 24.5\text{ mV}$, $R_L = 6\ \Omega$	60	82	—	dB
Standby terminal voltage	I_{CQ-STB}	$V_{IN} = \text{open}$, $V_{STB} = 5\text{ V}$	—	—	50	μA

Note) *1 : Measurement using a bandwidth 15 Hz to 30 kHz (12 dB/OCT) filter.

*2 : $V_{CC} = 24\text{ V}$

■ Usage Notes

1. Always attach an outside heat sink when using the chip. In addition, the outside heat sink must be fastened onto a chassis for use.
2. Connect the cooling fin to GND potential.
3. Avoid short circuit to V_{CC} and short circuit to GND, and load short-circuit.
4. The temperature protection circuit will be actuated at $T_j = \text{approx. } 150^\circ\text{C}$.
However, it is automatically reset when the chip temperature drops below the above set level.
5. The overvoltage protection circuit starts its operation at $V_{CC} = \text{approx. } 26\text{ V}$.
6. For the standby voltage, a stabilized power supply of 3 V or higher should be used.
7. Only when being used in combination with the AN7077Z, this IC can operate up to the supply voltage of approx. 25.4 V which is the maximum output voltage of the AN7077Z.

■ Technical Information

• $P_D - T_a$ curves of packages

Note) After fixing all of the lead wires to printed circuit board by soldering, use the IC after fixing the printed circuit board and the cooling fin of the IC.

• AN7194K (HZIP016-P-0665B)

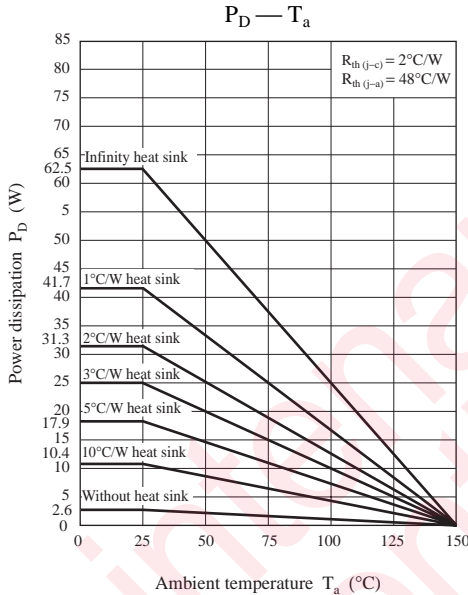

• AN7194Z (HZIP015-P-0745A)

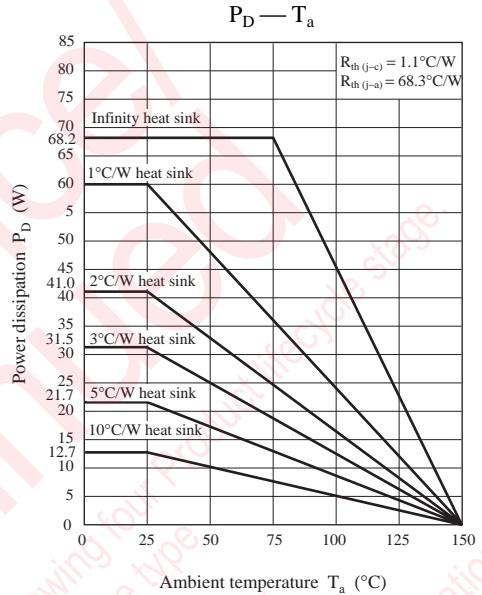

■ Application Circuit Example

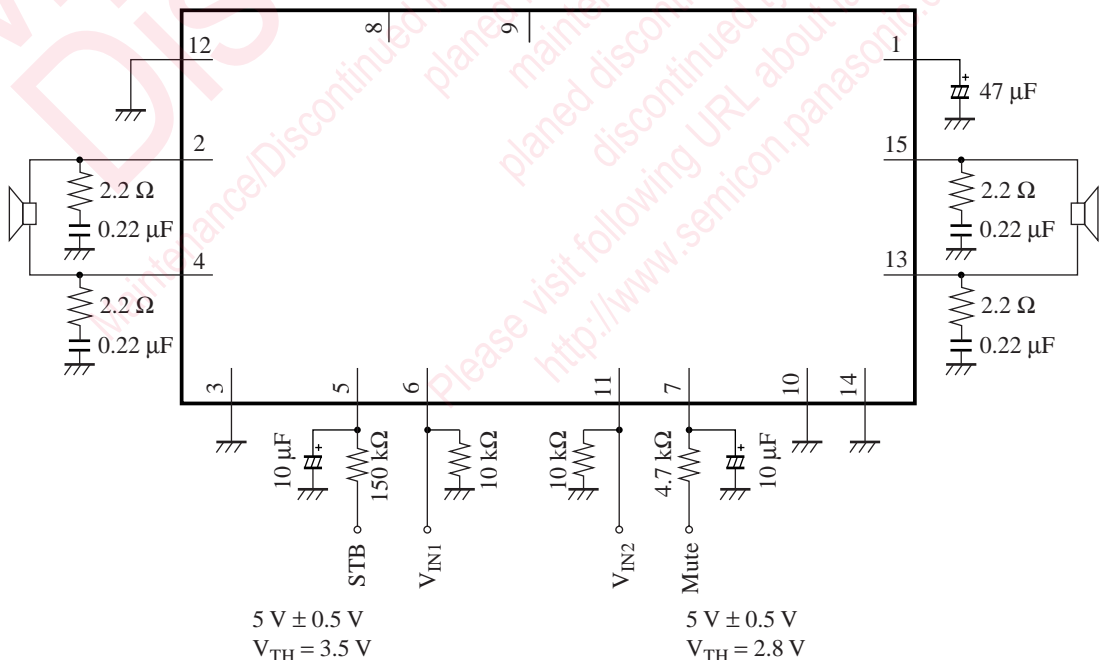

Request for your special attention and precautions in using the technical information and semiconductors described in this book

- (1) If any of the products or technical information described in this book is to be exported or provided to non-residents, the laws and regulations of the exporting country, especially, those with regard to security export control, must be observed.
- (2) The technical information described in this book is intended only to show the main characteristics and application circuit examples of the products, and no license is granted under any intellectual property right or other right owned by our company or any other company. Therefore, no responsibility is assumed by our company as to the infringement upon any such right owned by any other company which may arise as a result of the use of technical information described in this book.
- (3) The products described in this book are intended to be used for standard applications or general electronic equipment (such as office equipment, communications equipment, measuring instruments and household appliances).
Consult our sales staff in advance for information on the following applications:
 - Special applications (such as for airplanes, aerospace, automobiles, traffic control equipment, combustion equipment, life support systems and safety devices) in which exceptional quality and reliability are required, or if the failure or malfunction of the products may directly jeopardize life or harm the human body.
 - Any applications other than the standard applications intended.
- (4) The products and product specifications described in this book are subject to change without notice for modification and/or improvement. At the final stage of your design, purchasing, or use of the products, therefore, ask for the most up-to-date Product Standards in advance to make sure that the latest specifications satisfy your requirements.
- (5) When designing your equipment, comply with the range of absolute maximum rating and the guaranteed operating conditions (operating power supply voltage and operating environment etc.). Especially, please be careful not to exceed the range of absolute maximum rating on the transient state, such as power-on, power-off and mode-switching. Otherwise, we will not be liable for any defect which may arise later in your equipment.
 - Even when the products are used within the guaranteed values, take into the consideration of incidence of break down and failure mode, possible to occur to semiconductor products. Measures on the systems such as redundant design, arresting the spread of fire or preventing glitch are recommended in order to prevent physical injury, fire, social damages, for example, by using the products.
- (6) Comply with the instructions for use in order to prevent breakdown and characteristics change due to external factors (ESD, EOS, thermal stress and mechanical stress) at the time of handling, mounting or at customer's process. When using products for which damp-proof packing is required, satisfy the conditions, such as shelf life and the elapsed time since first opening the packages.
- (7) This book may be not reprinted or reproduced whether wholly or partially, without the prior written permission of Matsushita Electric Industrial Co., Ltd.