

# H1 Series

## Silicon and InGaAs-APD Receiver

### Description

The H1-Series includes a silicon or InGaAs avalanche photodiode with an optimized low noise hybrid preamplifier for the use in laser range finding, LIDAR, medical and analytical applications. Housed in a 12 pin TO-8 package they offer bandwidths up to 25 MHz, an onboard temperature sensor and a single ended output.

The Si-APDs used in these devices are SAR500, SAR1500, SAR3000 and for YAG enhanced application SAT800, providing excellent responsivity between 400 nm and 1100 nm and very fast rise and fall times at all wavelengths. For the wavelength range between 900 nm and 1700 nm our InGaAs-APD IAG-Series is used.

All APD receivers are available with various gain/bandwidth configurations.

Custom versions with all other APD chips from our product range are available on request.

For field use we recommend using the receiver together with our ABC550-05. This temperature-compensated HV supply allows constant responsivity to be maintained despite changes in temperature. For a complete plug & play system we recommend our LCSA-/LCIA-Series.



### Features

- System bandwidth DC – 25 MHz
- High sensitivity
- Ultra low noise
- Spectral response range  
Si-APD: 400 nm to 1100 nm  
InGaAs-APD: 900 nm to 1700 nm
- Hermetically sealed TO-8 package
- Integrated temperature diode
- +/- 5 Volts amplifier operating voltage

### Applications

- Rangefinding / LIDAR
- Optical communication systems
- Laser scanners
- Spectroscopy
- Fluorescence
- Medical

### Generic Characteristics

	Min	Typ	Max	Units
Storage Temperature	-55		+100	°C
Operating Temperature	-40		+85	°C
TIA Supply Voltage	+/-4	+/-5	+/-6.5	Volts
TIA Supply Current		30		mA
Power Consumption		300		mW
Soldering (5 sec.)			200	°C

## Si-APD-Receiver, SARxxxxH1-Series

Fig. 1: Spectral Response @ M = 100 (SAR500H1D)

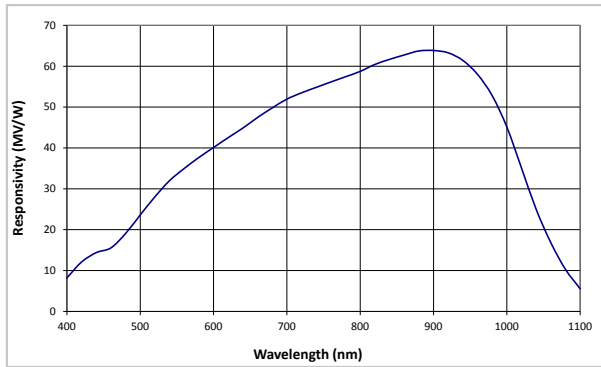
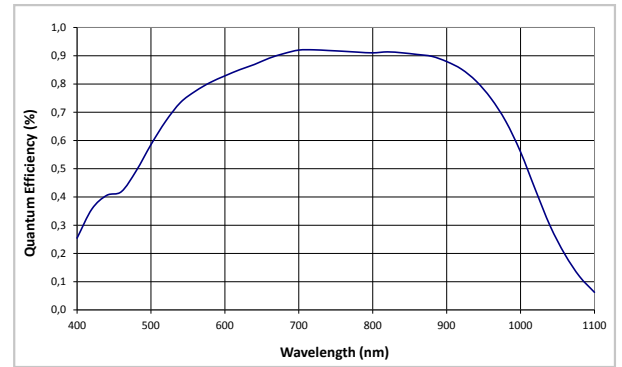

Fig. 2: Quantum Efficiency vs. Wavelength



### Electrical Characteristics @ M = 100, Ta = 25°C (typical values)

Part Number	SAR500H1A	SAR500H1B	SAR500H1C	SAR500H1D	Units
Si-APD	SAR500	SAR500	SAR500	SAR500	
Active Area Diameter	0.5	0.5	0.5	0.5	mm
Wavelength Range	400 – 1000	400 – 1000	400 – 1000	400 – 1000	nm
Peak Sensitivity	905	905	905	905	nm
Bandwidth	DC – 25	DC -10	DC – 3	DC -1	MHz
Responsivity					
540 nm	0.27	2.7	27	270	MV/W
650 nm	0.4	4	40	400	MV/W
905 nm	0.5	5	50	500	MV/W
NEP					
540 nm	150	55	11	11	fW/rtHz
650 nm	100	37.5	7.5	7.5	fW/rtHz
905 nm	80	30	6	6	fW/rtHz
Output Noise Density	40	150	300	3000	nV/rtHz
Input Referred Noise Density	4	1.5	0.3	0.3	pA/rtHz
Output Voltage Swing (1 MΩ)	3	3	3	3	V
Output Voltage Swing (50 Ω)	1.5	1.5	1.5	1.5	V
Output Offset Voltage	50	50	50	50	mV

Electrical Characteristics @  $M = 100$ ,  $T_a = 25^\circ\text{C}$  (typical values)

Part Number	SAR1500H1A	SAR1500H1B	SAR1500H1C	SAR1500H1D	Units
Si-APD	SAR1500	SAR1500	SAR1500	SAR1500	
Diameter	1.5	1.5	1.5	1.5	mm
Wavelength Range	400 – 1000	400 – 1000	400 – 1000	400 – 1000	nm
Peak Sensitivity	905	905	905	905	nm
Bandwidth	DC – 25	DC -10	DC – 3	DC -1	MHz
Responsivity					
540 nm	0.27	2.7	27	270	MV/W
650 nm	0.4	4	40	400	MV/W
905 nm	0.5	5	50	500	MV/W
NEP					
540 nm	150	55	37	11	fW/rtHz
650 nm	100	37.5	25	7.5	fW/rtHz
905 nm	80	30	20	6	fW/rtHz
Output Noise Density	40	150	1000	3000	nV/rtHz
Input Referred Noise Density	4	1.5	1	0.3	pA/rtHz
Output Voltage Swing (1 M $\Omega$ )	3	3	3	3	V
Output Voltage Swing (50 $\Omega$ )	1.5	1.5	1.5	1.5	V
Output Offset Voltage	0.1	0.1	0.1	0.1	V

Electrical Characteristics @  $M = 100$ ,  $T_a = 25^\circ\text{C}$  (typical values)

Part Number	SAR3000H1A	SAR3000H1B	SAR3000H1C	SAR3000H1D	Units
Si-APD	SAR3000	SAR3000	SAR3000	SAR3000	
Diameter	3	3	3	3	mm
Wavelength Range	400 – 1000	400 – 1000	400 – 1000	400 – 1000	nm
Peak Sensitivity	905	905	905	905	nm
Bandwidth	DC – 25	DC -10	DC – 3	DC -1	MHz
Responsivity					
540 nm	0.27	2.7	27	270	MV/W
650 nm	0.4	4	40	400	MV/W
905 nm	0.5	5	50	500	MV/W
NEP					
540 nm	225	55	37	15	fW/rtHz
650 nm	150	38	25	11	fW/rtHz
905 nm	120	30	20	9	fW/rtHz
Output Noise Density	60	150	1000	4000	nV/rtHz
Input Referred Noise Density	6	1.5	1	0.4	pA/rtHz
Output Voltage Swing (1 M $\Omega$ )	3	3	3	3	V
Output Voltage Swing (50 $\Omega$ )	1.5	1.5	1.5	1.5	V
Output Offset Voltage	0.1	0.1	0.1	0.1	V

## Notes:

- Noise measured at 100 kHz.
- H1C and H1D versions are extremely sensitive to background light. Operation in daylight is not recommended.
- All detailed specifications about the integrated APD is given in the data sheet of the SAR500-series or SAR1500/3000-series.
- Pulsed operation

## Si-APD-Receiver, SAT800H1-Series

Fig. 1: Spectral Response @ M = 100 (SAT800H1D)

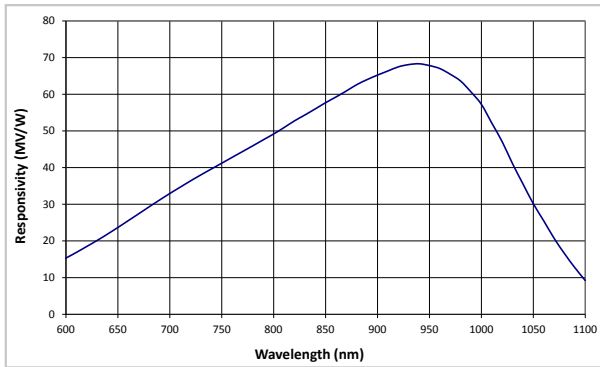
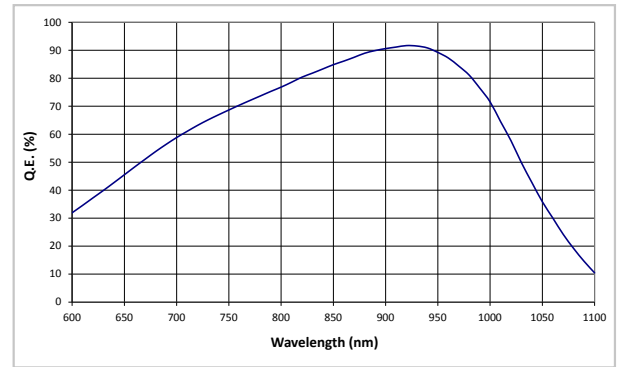

Fig. 2: Quantum Efficiency vs. Wavelength



### Electrical Characteristics @ M = 100, Ta = 25°C (typical values)

Part Number	SAT800H1A	SAT800H1B	SAT800H1C	SAT800H1D	Units
Si-APD	SAT800	SAT800	SAT800	SAT800	
Diameter	0.8	0.8	0.8	0.8	mm
Wavelength Range	700 – 1100	700 – 1100	700 – 1100	700 – 1100	nm
Peak Sensitivity	940	940	940	940	nm
Bandwidth	DC – 25	DC -10	DC – 3	DC -1	MHz
Responsivity					
540 nm	0.27	2.7	27	270	MV/W
650 nm	0.4	4	40	400	MV/W
905 nm	0.5	5	50	500	MV/W
NEP					
540 nm	150	55	11	11	fW/rtHz
650 nm	100	38	7.5	7.5	fW/rtHz
905 nm	80	30	6	6	fW/rtHz
Output Noise Density	40	150	300	3000	nV/Hz
Input Referred Noise Density	4	1.5	0.3	0.3	pA/Hz

Notes:

- Noise measured at 100 kHz.
- H1C and H1D versions are extremely sensitive to background light. Operation in daylight is not recommended.
- All detailed specifications about the integrated APD is given in the data sheet of the SAT-series.
- An export license is required by customers outside the USA.

## InGaAs-APD-Receiver, IAG200H1-Series

Fig. 1: Spectral Response @ M = 10

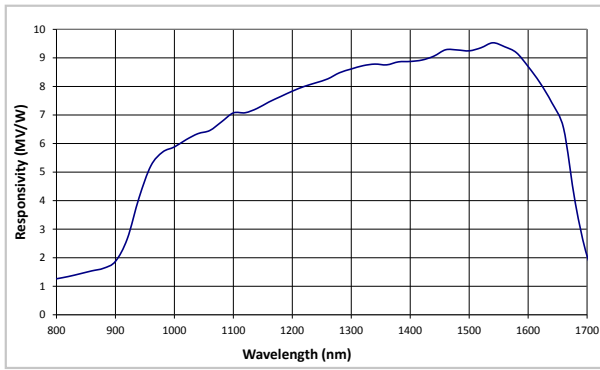
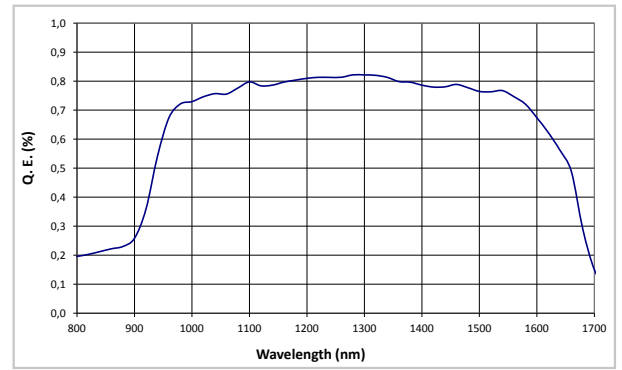

Fig. 2: Quantum Efficiency vs. Wavelength



### Electrical Characteristics @ M = 10, T<sub>a</sub> = 25°C (typical values)

Part Number	IAGXXXH1A	IAGXXXH1B	IAGXXXH1C	IAGXXXH1D	Units
InGaAs-APD <sup>3</sup>	IAG-Series	IAG-Series	IAG-Series	IAG-Series	
Diameter <sup>3</sup>	80 / 200 / 350	80 / 200 / 350	80 / 200 / 350	80 / 200 / 350	µm
Wavelength Range	900 - 1700	900 - 1700	900 - 1700	900 - 1700	nm
Peak Sensitivity	1550	1550	1550	1550	nm
Bandwidth	DC – 25	DC -10	DC – 3	DC -1	MHz
Responsivity 1550 nm	0.094	0.94	9.4	94	MV/W
NEP 1550 nm	425	160	64	32	fW/rtHz
Output Noise Density	40	150	600	3000	nV/rtHz
Input Referred Noise Density	4	1.5	0.6	0.3	pA/rtHz

Notes:

- Noise measured at 100 kHz.
- H1C and H1D versions are extremely sensitive to background light. Operation in daylight is not recommended.
- All detailed specifications about the integrated APD is given in the data sheet of the IAG-series.

Product Number Designations

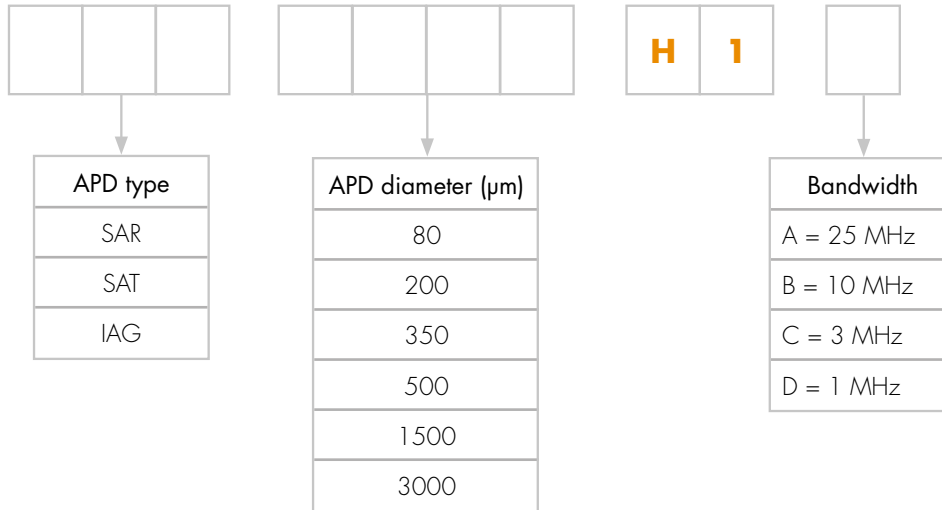

Series Block Diagram

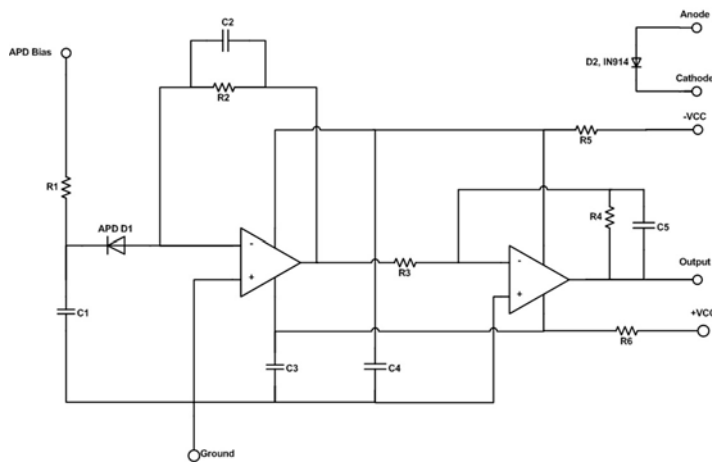

Note:

Positive bias configuration is supplied as standard but negative can be ordered by request. Please insure that the correct APD bias polarity is being supplied. However, a current limiting resistor must be placed in series with the avalanche photodiode bias voltage to limit the current into the transimpedance amplifier. All series will handle a maximum of 1 mA of bias on the APD. Please ensure that the APD bias is limited to less than 1 mA. Use the supplied, serialized data sheet for each device for correct operating bias value and maximum bias value (V<sub>bkdn</sub>) that can be used. Failure to limit this current may result in permanent failure of the device.

Package Drawings - Dimensions in mm [inches]

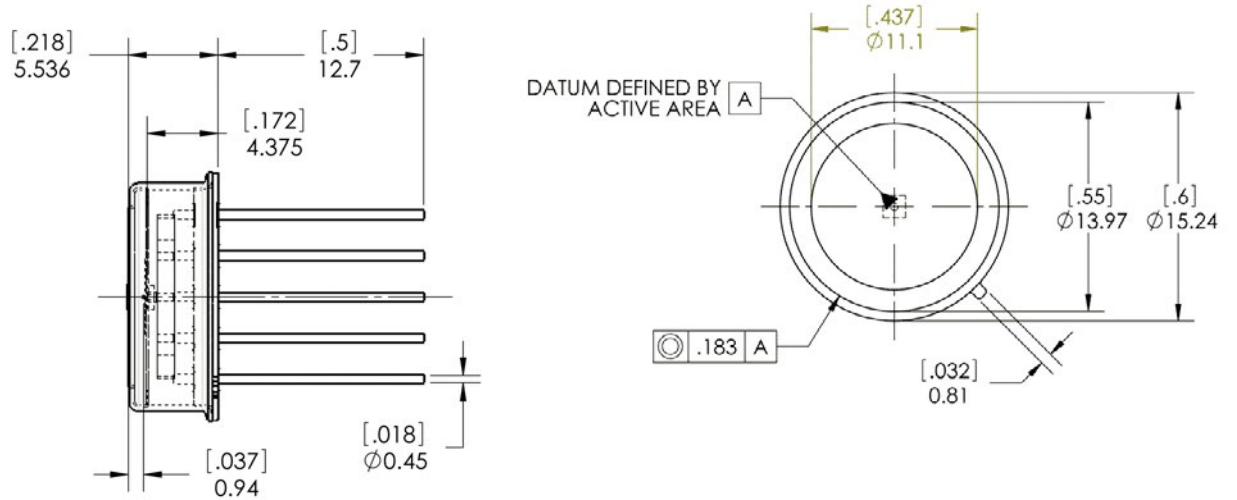

PIN Configuration

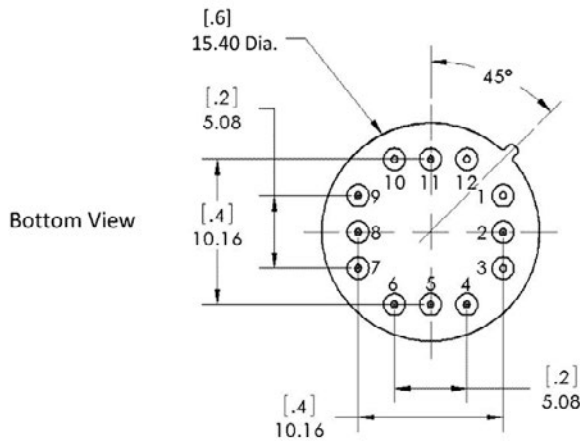

- PIN #1: OUTPUT
- PIN #2: NC
- PIN #3: -5V
- PIN #4: HV BIAS
- PIN #5: NC
- PIN #6: CASE
- PIN #7: COMMON
- PIN #8: TEMP +
- PIN #9: TEMP -
- PIN #10: COMMON
- PIN #11: NC
- PIN #12: +5V