

Features

- Fully Integrated Transmit and Receive Functions
- Operates with +3 V to +5 V Supply Voltage
- Low 24 mA Receive Current
- High Receiver Dynamic Range (IP₃ = -2 dBm)
- On-Chip Receive Image Rejection (18 dB @ 350 MHz IF)
- Low Transmit Mode Current: 40 mA @ 5 V
- Low Power Standby Operating Mode
- Receive & Transmit Operating Modes

Description

M/A-COM's MD58-0033 is a highly integrated front-end transceiver with exceptional RF performance. The transceiver is ideally suited for FSK or linear systems in the 2.4 -2.5 GHz ISM band. The receive chain includes an LNA, image rejection filter, and a balanced mixer suitable for high data rate applications. The transmit chain uses single-ended or balanced IF input to drive an upconverting balanced mixer, and an RF combiner to provide exceptional output spurious performance. Applications for this transceiver include WLAN, WPBX and portable data terminals demanding low power consumption. The transceiver can be used alone for low-power transmission, or in conjunction with M/A-COM's AM55 series 2.4 GHz power amplifiers for higher power applications. The MD58-0033 is a drop-in replacement for the MD58-0005 transceiver.

M/A-COM fabricates the MD58-0033 using a low-noise GaAs E/D MESFET process that features full chip passivation for performance and reliability.

Transceiver Truth Table

PINS	Receive Mode	Transmit Mode	Standby Mode
4, 13 (Rx LOGIC)	1	0	0
3, 16 (Tx LOGIC)	0	1	0
28 (LO LOGIC)	1	1	0

"0" = -5 V @ 100 μ A Typ. To -6 V @ 200 μ A Typ.

"1" = 0 V to -0.2 V @ 100 μ A Typ.

Functional Schematic

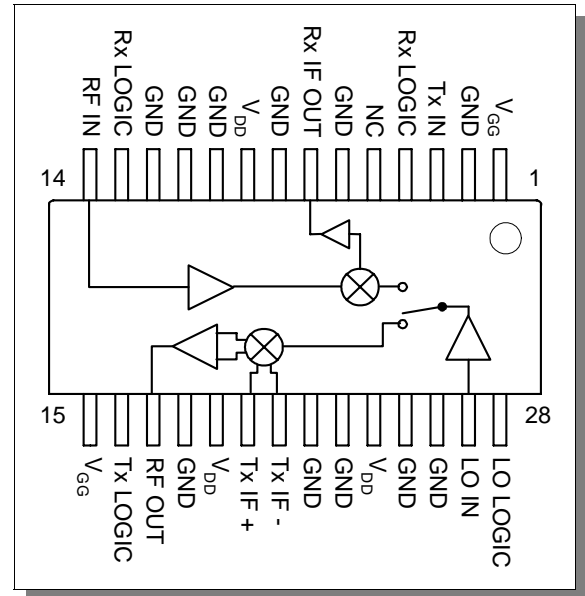

Pin Configuration

Pin No.	Pin Name	Description
1	V _{GG}	Negative Supply Voltage (-5 V)
2,6,8,10, 11,12,18, 22,23,25, 26,	GND	DC and RF Ground
3	Tx Logic	Logic control line for transmit functions
4	Rx Logic	Logic control line for receive functions
5	NC	No connection
7	Rx IFOUT	Receive IF output, external LC match and bias injection
9	V _{DD}	Positive Supply Voltage (+5 V)
13	Rx Logic	Logic control line for receive functions
14	RF IN	RF input to the receive LNA, internally AC coupled, Z _{IN} = 50 Ω
15	V _{GG}	Negative Supply Voltage (-5 V)
16	Tx Logic	Logic control line for transmit functions
17	RF OUT	Transmit RF output, internally AC coupled, Z _{OUT} = 50 Ω
19	V _{DD}	Positive Supply Voltage (+5 V)
20	Tx IF+	Single-ended transmit IF input, or first of two balanced IF inputs, externally AC coupled
21	Tx IF-	Transmit IF input, second of two balanced IF inputs, externally AC coupled to ground for single-ended operation
24	V _{DD}	Positive Supply Voltage (+5 V)
27	LO IN	LO buffer input, internally AC coupled,
28	LO LOGIC	Logic control line for LO buffer functions

Electrical Specifications: RF = 2.5 GHz, IF = 350 MHz, LO = -5 dBm, $V_{DD} = +5 V \pm 5\%$, $V_{GG} = -5 V \pm 10\%$ ⁴, $T_A = +25^\circ C$

Parameter	Test Conditions	Units	Min.	Typ.	Max.
Receive Mode					
RF Frequency Range	IF output Impedance ¹ Externally matched to 50Ω	GHz	2.4		2.5
IF Frequency Range		MHz	50 ⁴		400
Conversion Gain		dB	10	12	
SSB Noise Figure		dB		5.1	6.5
Input P _{1dB}		dBm		-10	
V _{DD} (+5V) Current		mA		24	35
V _{GG} (-5V) Current		mA		0.5	1.5
Transmit Mode					
RF Frequency Range	IF input ² of -8 dBm	GHz	2.4		2.5
IF Frequency Range		MHz	200		400
RF Output Power		dBm	-2	2	
LO Leakage Level		dBm		-18	-12
Output Spurious Levels in RF Band		dBc	45	57	
V _{DD} (+5 V) Current		mA		40	60
V _{GG} (-5 V) Current		mA		0.5	1.5
Standby Mode					
V _{DD} (+5 V) Current		mA		1.5	3.0
V _{GG} (-5 V) Current		mA		0.5	1.5

1. The receive IF output impedance is 300 ohms. An external LC circuit is used for impedance matching and bias injection
2. The transmit IF input impedance is 100 ohms, single ended.
3. In-band spurious, 7IF and 2 LO-5IF.
4. Image rejection for IF down to 200 MHz, We recommend -8 to -2 dBm LO drive.

Absolute Maximum Ratings ¹

Parameter	Absolute Maximum
Max Input Power	+20 dBm
Operating Voltages	$V_{DD} = 6 V, V_{GG} = -6 V$
Operating Temperature	-40 °C to +85 °C
Storage Temperature	-65 °C to +150 °C

1. Exceeding these limits may cause permanent damage.
2. Ambient temperature (T_A) = +25°C

Specifications subject to change without notice.

- North America: Tel. (800) 366-2266
- Asia/Pacific: Tel.+81-44-844-8296, Fax +81-44-844-8298
- Europe: Tel. +44 (1344) 869 595, Fax+44 (1344) 300 020

Visit www.macom.com for additional data sheets and product information.

General Information

The MD58-0033 is a highly integrated MMIC transceiver designed for the 2.4-2.5 GHz ISM band. The transceiver provides exceptional RF performance while consuming low DC current and is packaged in a low cost plastic package. It is ideal for light weight battery operated portable radio systems.

The receive chain consists of an LNA, an image reject filter, a balanced mixer and a single ended IF output buffer. The entire receiver consumes only 24 mA while achieving 12 dB gain and 5 dB of SSB NF with an IIP₃ of -2 dBm. The transmit chain consists of a double-balanced mixer and an RF combiner to provide low in-band output spurious while consuming only 40 mA. The LO signal is amplified by an on-chip buffer and injected to the receive and transmit mixers by a LO switch.

The RF output, RF input and LO input ports are designed for a 50-ohm impedance. All RF ports are internally AC coupled. The receive IF output impedance is 300 ohms. For the Receive IF output, external components are used for impedance matching and bias injection. The transmit IF inputs are designed for 100-ohm impedance (200-ohm differential).

Transceiver Operation Modes

The transceiver is designed for three modes of operation, transmit, receive and stand-by. These modes are set by using three logic lines: one for receive, a second for transmit and a third logic line for the LO buffer. These logic lines allow rise times within micro seconds for fast “turn-on” and “turn-off” of each function. (See the transceiver truth table for logic and voltage levels.)

Bias Sequence

The transceiver bias sequence is as follows; 1) always make the ground connection first, 2) apply the V_{GG} supply voltage, 3) connect all logic lines to the logic “0” so the transceiver will bias up in the stand-by mode when the positive supply is connected, 4) apply the V_{DD} supply voltage and change the logic levels as desired.

External Components and Circuit Board Layout

This data sheet contains a suggested PCB layout and schematic to follow when designing a full radio board. For more detailed information, contact the number listed below. The external components serve two basic functions. The first purpose is to bypass the power supply lines since all power supply lines require external capacitive bypass to present an AC short over a wide frequency band. The second use is for LC matching/bias injection for the receive IF output, as described.

Receive IF Output Impedance

The receiver is designed for an output impedance of 300 ohms. The receive IF output also requires a V_{DD} bias. Using an external “LC match,” as shown in the figure below, the IF output impedance matching and bias injection can be accommodated simultaneously. The table below shows suggested matching elements for various IF frequencies when matching to 50 ohms. Element values may vary slightly depending on component vendor and radio board layout.

Receive IF Output Matching

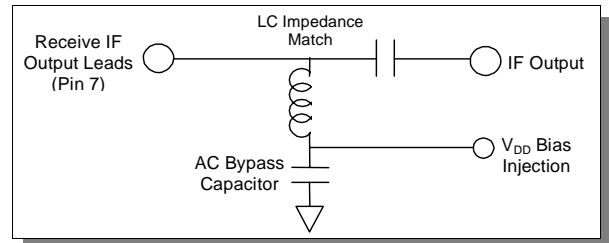

Receive IF Frequency Matching

IF Frequency (MHz)	Shunt Inductor	Series Capacitor
200 - 249	90 nH	6 pF
250 - 299	68 nH	4 pF
300 - 349	58 nH	4 pF
350 - 400	47 nH	3 pF

Test Set-up Information

The following two figures illustrate the test set-up suggested for transceiver evaluation, indicating the power levels used for the data displayed in the typical performance figures

Receive Test Set-up

The receive gain is measured as the total combined IF output power. Receiver small signal gain measurements are made for -20 dBm RF input power. The figure shows the typical receiver test set-up. The LO drive level is -5 dBm. Transmit ports should be terminated in 50 ohms.

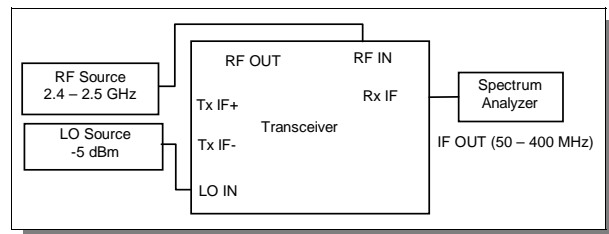

Specifications subject to change without notice.

- North America: Tel. (800) 366-2266
- Asia/Pacific: Tel.+81-44-844-8296, Fax +81-44-844-8298
- Europe: Tel. +44 (1344) 869 595, Fax+44 (1344) 300 020

Visit www.macom.com for additional data sheets and product information.

Transmit Test Set-up

The IF input power level is typically -8 dBm and the LO input power level is -5 dBm. Receive ports should be terminated in 50 ohms.

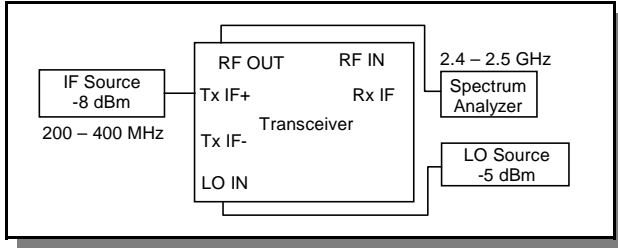

Typical Measured Results

Measured results for a typical board mounted transceiver sample are shown in the performance curve section of this data sheet. The measurements were made using the test set-up described for receive and transmit. The board used for these measurements is the MD58-0033SMB, or transceiver evaluation board. This evaluation board can be ordered for engineering evaluation.

Typical Receiver Performance Characteristics ¹

Gain and NF vs. RF Frequency

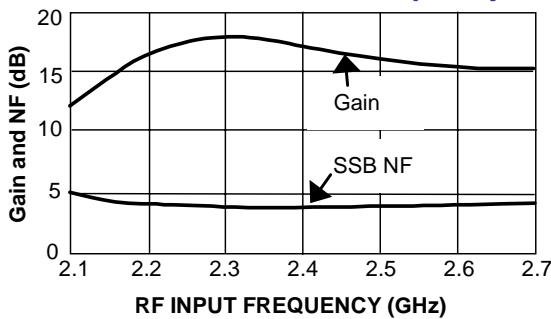

Gain, NF and P_{1dB} vs. Low Power

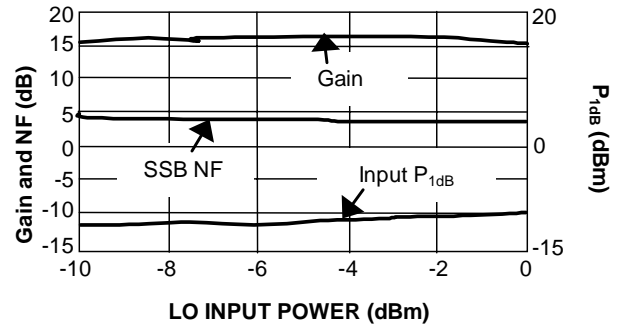

Input Compression vs. RF Frequency

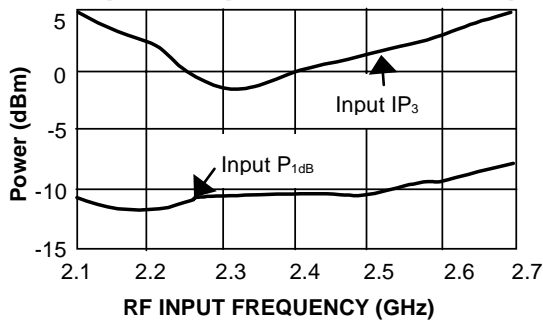

Gain, NF and P_{1dB} vs. Power Supply

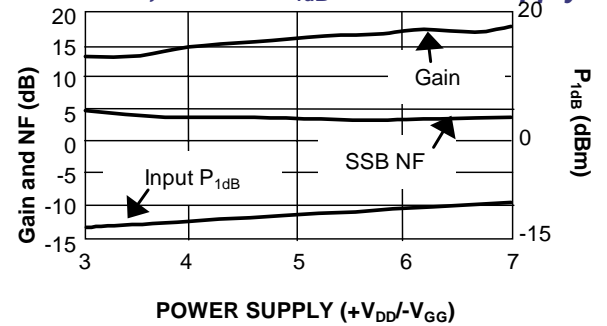

Gain and Noise Figure vs. IF Frequency

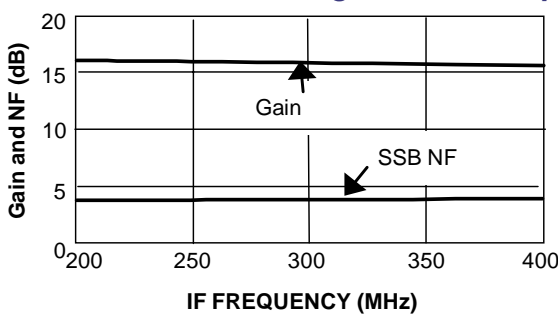

Gain, NF and P_{1dB} vs. Temperature

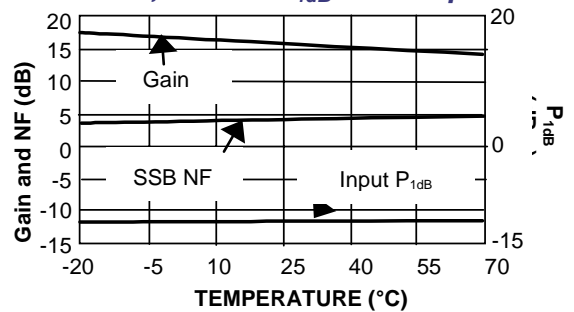

1. Test conditions unless otherwise specified:
RF = 2.5 GHz, IF = 350 MHz, LO Input Power = -5 dBm (@ 2.15 GHz), V_{DD} = +5 V, V_{GG} = -5 V, T_A = +25 °C

Specifications subject to change without notice.

- North America: Tel. (800) 366-2266
- Asia/Pacific: Tel. +81-44-844-8296, Fax +81-44-844-8298
- Europe: Tel. +44 (1344) 869 595, Fax +44 (1344) 300 020

Visit www.macom.com for additional data sheets and product information.

Typical Receiver Performance Characteristics ¹

Power Output vs. RF Frequency

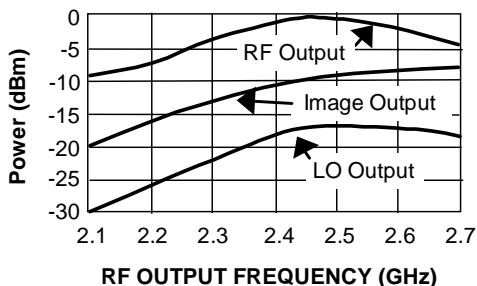

Power Output vs. LO Power

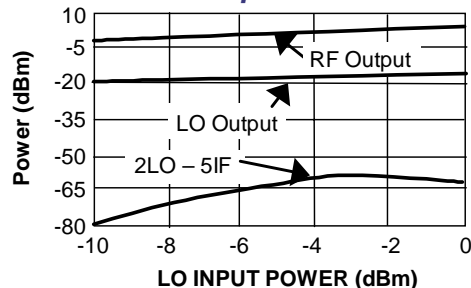

Power Output vs. IF Power

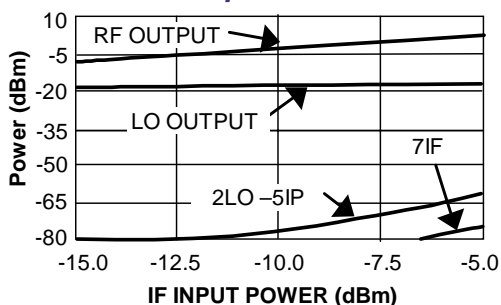

Power Output vs. Power Supply

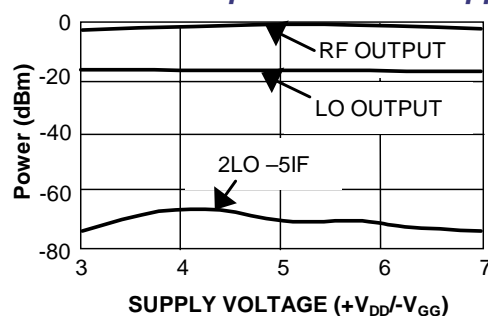

Power Output vs. IF Frequency

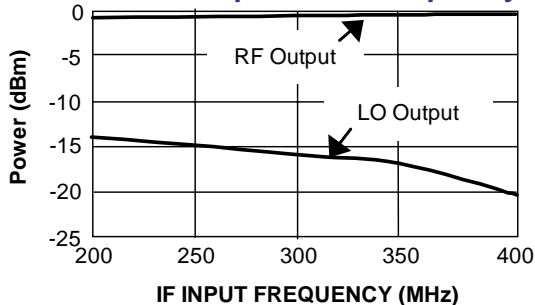

Power Output vs. Temperature

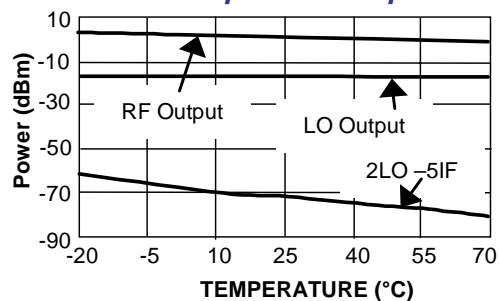

1. Test conditions unless otherwise specified:
 RF = 2.5 GHz, IF = 350 MHz, LO Input Power = -5 dBm (@ 2.15 GHz), V_{DD} = +5V, V_{GG} = -5 V, T_A = +25 °C

Specifications subject to change without notice.

- North America: Tel. (800) 366-2266
- Asia/Pacific: Tel.+81-44-844-8296, Fax +81-44-844-8298
- Europe: Tel. +44 (1344) 869 595, Fax+44 (1344) 300 020

Visit www.macom.com for additional data sheets and product information.

Recommended PCB Configuration
(for Single Ended Transmit IF)

Layout View

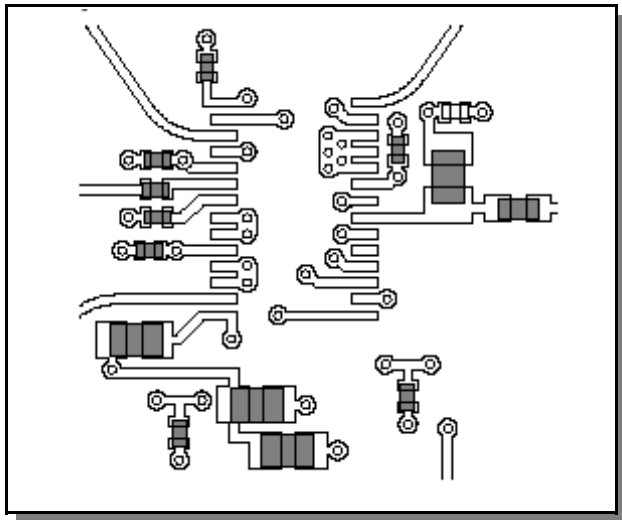

Cross Section View

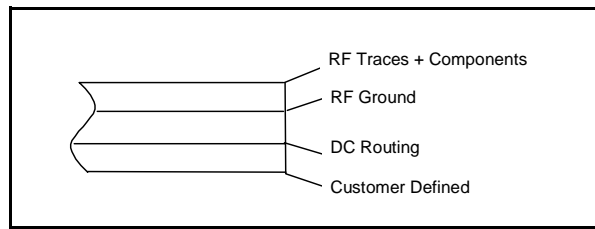

The PCB dielectric between RF traces and RF ground layers should be chosen to reduce RF discontinuities between 50-Ω lines and package pins. M/A-COM recommends an FR-4 dielectric thickness of 0.008 in. (0.2 mm), yielding a 50-Ω line width of 0.015 in. (0.38 mm). The recommended metalization thickness is 1 oz. copper.

Biasing Procedure

The MD58-0033 requires that V_{GG} bias be applied prior to *any* V_{DD} bias. Permanent damage may occur if this procedure is not followed.

External Circuitry

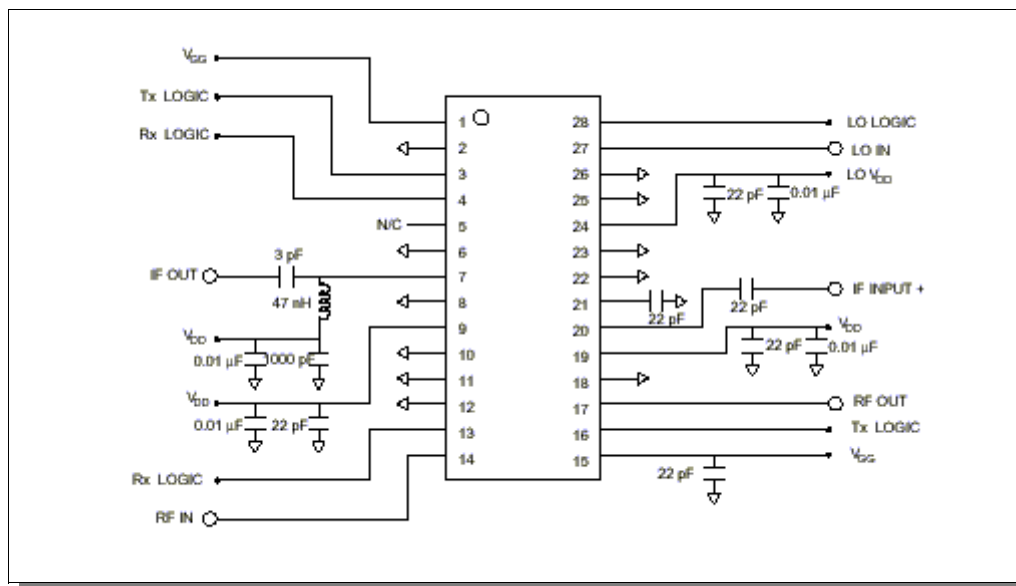

Specifications subject to change without notice.

- North America: Tel. (800) 366-2266
- Asia/Pacific: Tel.+81-44-844-8296, Fax +81-44-844-8298
- Europe: Tel. +44 (1344) 869 595, Fax+44 (1344) 300 020

Visit www.macom.com for additional data sheets and product information.

Designer's Kit (MD58-0033SMB)

The MD58-0033SMB Designer's Kit allows for immediate evaluation of M/A-COM's MD58-0033 integrated transceiver without the delays or cost of designing evaluation test boards. The evaluation board consists of the MD58-0033, recommended external surface mount circuitry, RF connectors and a DC multi-pin connector, all mounted to a multi-layer FR-4 PCB.

Transceiver Sample Board

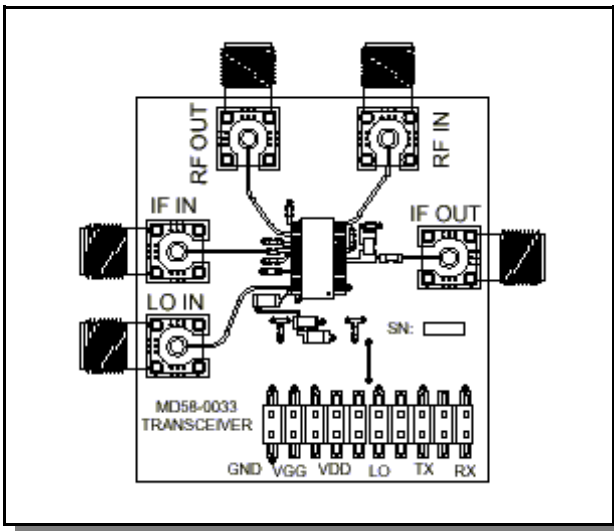

Transceiver Sample Board

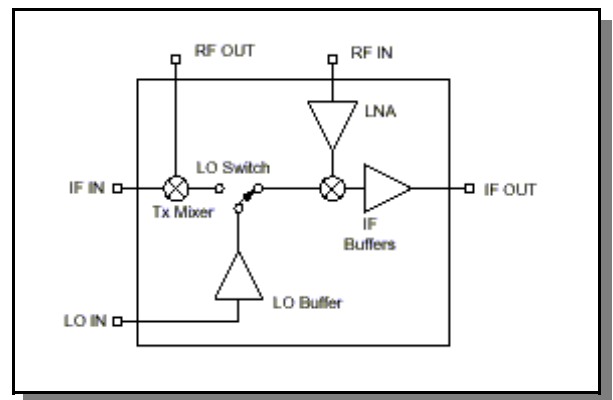

DC Connector Pinout

Pin	Function/DC Volt	Device Pin Number
1	Gnd / 0 V	GND PINS
2	GND / 0 V	GND PINS
3	V _{GG} / -5 V	1, 15
4	V _{GG} / -5 V	1, 15
5	V _{DD} / +5 V	7, 9, 19, 24
6	V _{DD} / +5 V	7, 9, 19, 24
7	NC	NC
8	NC	NC
9	NC	NC
10	NC	NC

Pin	Function/DC Volt	Device Pin Number
12	LO LOGIC	28
12	LO LOGIC PULLUP	NC
13	NC	NC
14	NC	NC
15	Tx LOGIC	3, 16
16	Tx LOGIC PULLUP	NC
17	NC	NC
18	NC	NC
19	Rx LOGIC	4, 13
20	Rx LOGIC PULLUP	NC

Specifications subject to change without notice.

- North America: Tel. (800) 366-2266
- Asia/Pacific: Tel.+81-44-844-8296, Fax +81-44-844-8298
- Europe: Tel. +44 (1344) 869 595, Fax+44 (1344) 300 020

Visit www.macom.com for additional data sheets and product information.

PCB DC Connector Jumper Settings

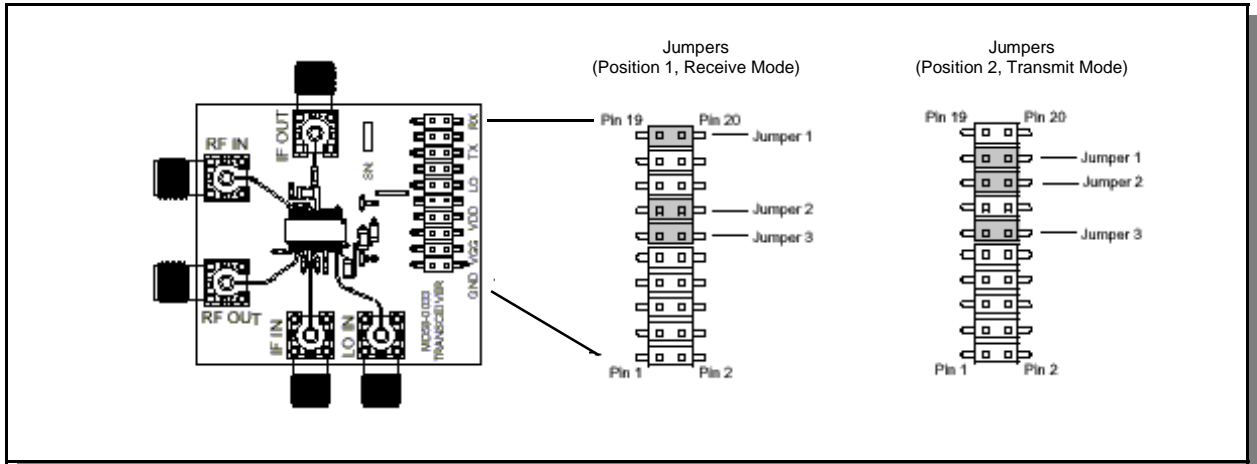

- Jumper 1 (Receive Control) Position 1 = Receive Functions "On"
Position 2 = Receive Functions in "Sleep Mode"
- Jumper 2 (Transmit Control) Position 1 = Transmit Functions in "Sleep Mode"
Position 2 = Transmit Functions "On"
- Jumper 3 (LO Control) Position 1, Position 2 = LO Buffer Functions "On,"
Remove Jumper to disable LO Buffer

MD58-0033SMB Biasing Procedure

In order to prevent transients which may damage the MMIC, please adhere to the following procedure.

- Turn on all power supplies and set all voltages to 0 volts BEFORE connecting the power supplies to the DC connector.
- Connect pin 1 or 2 to ground.
- Set jumpers for desired test mode.
- Apply a -5.0 volt supply to DC connector pin 3 or 4 (V_{GG}).
- Apply a +5.0 volt supply to the DC connector pin 5 or 6 (V_{DD}).
- Adjust V_{GG} supply to -5 volts.
- Adjust all V_{DD} supplies to +5 volts.
- Hot switching of jumpers will not damage device.
- To power off, reverse above procedure.
 1. Set V_{DD} to 0 volts.
 2. Set V_{GG} to 0 volts.
 3. Disconnect bias lines from DC connector.
 4. Turn off power supplies.

Evaluation PCB and RF Connector Losses

Port Reference	Approximate Loss (dB)
RF IN	0.2
RF OUT	0.2
IF IN	0.1
IF OUT	0.1
LO IN	0.2

The DC connector on the Designer's Kit PCB allows selection of all the devices operating modes. It is accomplished by one or more of the following methods:

1. A mating female multi-pin connector (Newark Electronics Stock # 46F-4658, not included)
2. Wires soldered to the necessary pins (not included)
3. Clip leads (not included)
4. A combination of clip leads or wires and jumpers (jumpers included as required)

Specifications subject to change without notice.

- North America: Tel. (800) 366-2266
- Asia/Pacific: Tel.+81-44-844-8296, Fax +81-44-844-8298
- Europe: Tel. +44 (1344) 869 595, Fax+44 (1344) 300 020

Visit www.macom.com for additional data sheets and product information.

QSOP-28

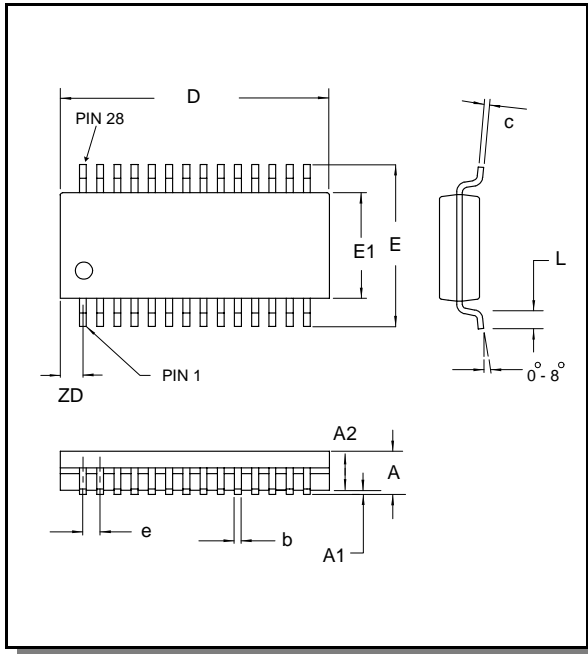

Dim	Measurement (mm)		
	Min.	Nom.	Max.
A	1.35	1.63	1.75
A1	0.10	0.15	0.25
A2	—	—	1.50
b	0.20	—	0.30
D	9.80	9.91	10.00
e	0.635 basic	0.635 basic	0.635 basic
E	—	6.00	—
E1	3.81	3.91	3.99
L	0.41	0.64	1.27
ZD	—	0.84 ref.	—

1. See JEDEC MO-137 Variation AF for additional dimensional and tolerance information.
2. Also referred to as an SSOP-28 package.

Ordering Information

Part Number	Package
MD58-0033	QSOP-28 Lead Plastic Package
MD58-0033TR	Forward Tape and Reel ¹
MD58-0033SMB	Sample Test Board

1. If specific reel size is required, consult factory for part number assignment.

Specifications subject to change without notice.

- North America: Tel. (800) 366-2266
- Asia/Pacific: Tel.+81-44-844-8296, Fax +81-44-844-8298
- Europe: Tel. +44 (1344) 869 595, Fax+44 (1344) 300 020

Visit www.macom.com for additional data sheets and product information.