

TYPES SN54ALS518 THRU SN54ALS522, SN74ALS518 THRU SN74ALS522 8-BIT IDENTITY COMPARATORS

D2681, JUNE 1982—REVISED DECEMBER 1983

- Compares Two 8-Bit Words
- Choice of Totem-Pole or Open-Collector Outputs
- 'ALS518, 'ALS520, and 'ALS522 Have 20-k Ω Pull-up Resistors on Q Inputs
- Package Options Include Both Plastic and Ceramic Chip Carriers in Addition to Plastic and Ceramic DIPs
- Dependable Texas Instruments Quality and Reliability

TYPE	INPUT PULL-UP RESISTOR	OUTPUT FUNCTION AND CONFIGURATION
'ALS518	Yes	P = Q open-collector
'ALS519	No	P = Q open-collector
'ALS520	Yes	$\overline{P} = \overline{Q}$ totem-pole
'ALS521†	No	$\overline{P} = \overline{Q}$ totem-pole
'ALS522	Yes	$\overline{P} = \overline{Q}$ open-collector

†ALS521 is identical to 'ALS688

description

These identity comparators perform comparisons on two eight-bit binary or BCD words. The 'ALS518 and 'ALS519 provide P = Q outputs, while the 'ALS520, 'ALS521, and 'ALS522 provide $\overline{P} = \overline{Q}$ outputs. The 'ALS518, 'ALS519, and 'ALS522 have open-collector outputs. The 'ALS518, 'ALS520, and 'ALS522 feature 20-k Ω pull-up termination resistors on the Q inputs for analog or switch data.

The SN54ALS518 through SN54ALS522 are characterized for operation over the full military temperature range of -55°C to 125°C. The SN74ALS518 through SN74ALS522 are characterized for operation from 0°C to 70°C.

SN54ALS' . . . J PACKAGE

SN74ALS' . . . N PACKAGE

(TOP VIEW)

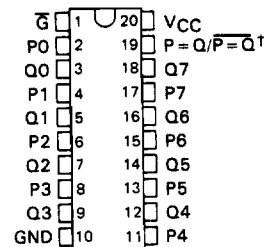

SN54ALS' . . . FH PACKAGE

SN74ALS' . . . FN PACKAGE

(TOP VIEW)

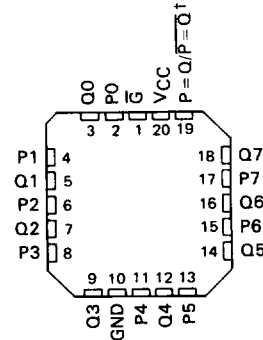

†P = Q for 'ALS518 and 'ALS519, and $\overline{P} = \overline{Q}$ for 'ALS520, 'ALS521, and 'ALS522.

FUNCTION TABLE

INPUTS		OUTPUTS	
DATA P, Q	ENABLE G	P = Q	$\overline{P} = \overline{Q}$
P = Q	L	H	L
P > Q	L	L	H
P < Q	L	L	H
X	H	L	H

2

ALS AND AS CIRCUITS

Copyright © 1982 by Texas Instruments Incorporated.

TYPES SN54ALS518 THRU SN54ALS522, SN74ALS518 THRU SN74ALS522 8-BIT IDENTITY COMPARATORS

logic symbols

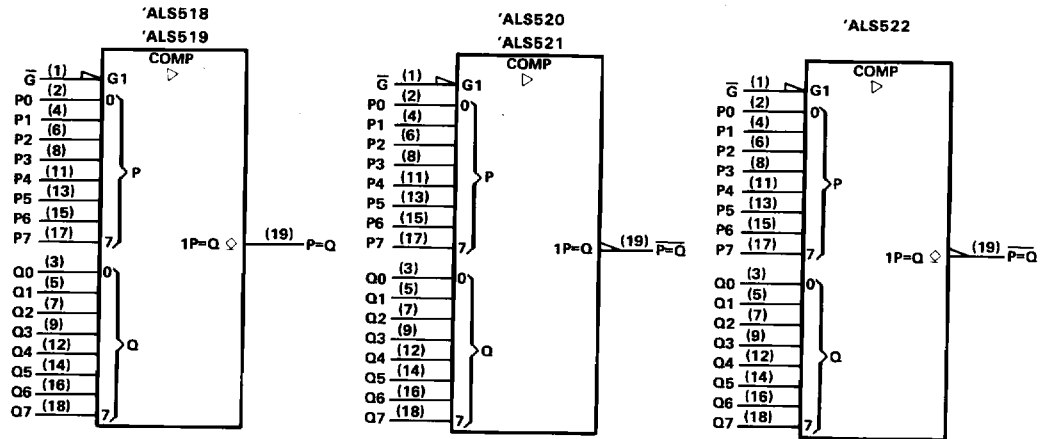

logic diagrams (positive logic)

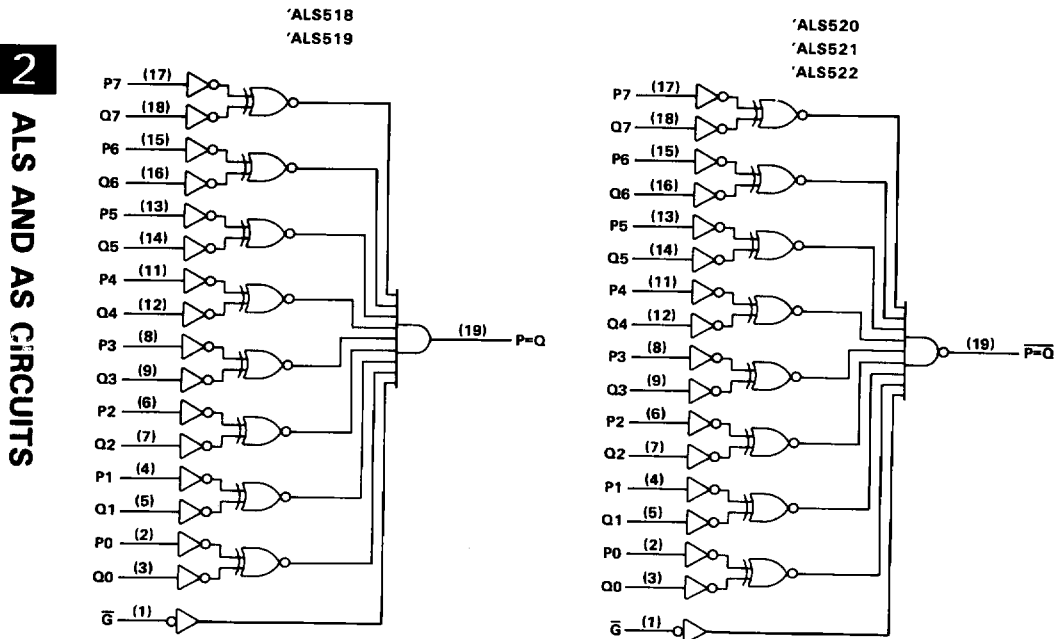

Pin numbers shown are for J and N packages.

TYPES SN54ALS518 THRU SN54ALS522, SN74ALS518 THRU SN74ALS522 8-BIT IDENTITY COMPARATORS

absolute maximum ratings over operating free-air temperature range (unless otherwise noted)

Supply voltage, V_{CC}	7 V
Input voltage: Q inputs of 'ALS518, 'ALS522	$V_{CC} + 0.5$ V or 5.5 V, whichever is less
All other inputs	7 V
Off-state output voltage	7 V
Operating free-air temperature range: SN54ALS518, SN54ALS519, SN54ALS522	-55 °C to 125 °C
SN74ALS518, SN74ALS519, SN74ALS522	0 °C to 70 °C
Storage temperature range	-65 °C to 150 °C

recommended operating conditions

	SN54ALS518 SN54ALS519 SN54ALS522			SN74ALS518 SN74ALS519 SN74ALS522			UNIT		
	MIN	NOM	MAX	MIN	NOM	MAX			
V_{CC} Supply voltage	4.5	5	5.5	4.5	5	5.5	V		
V_{IH} High-level input voltage	2			2			V		
V_{IL} Low-level input voltage	0.8			0.8			V		
V_{OH} High-level output voltage	5.5			5.5			V		
I_{OL} Low-level output current	12			24			mA		
T_A Operating free-air temperature	-55			125			0	70	°C

electrical characteristics over recommended operating free-air temperature range (unless otherwise noted)

PARAMETER	TEST CONDITIONS	SN54ALS518 SN54ALS519 SN54ALS522			SN74ALS518 SN74ALS519 SN74ALS522			UNIT
		MIN	TYP [†]	MAX	MIN	TYP [†]	MAX	
V_{IK}	$V_{CC} = 4.5$ V, $I_I = -18$ mA	-1.5			-1.5			V
I_{OH}	$V_{CC} = 4.5$ V, $V_{OH} = 5.5$ V	0.1			0.1			mA
V_{OL}	$V_{CC} = 4.5$ V, $I_{OL} = 12$ mA	0.25			0.25			V
	$V_{CC} = 4.5$ V, $I_{OL} = 24$ mA	0.35			0.5			
I_I	'ALS518, 'ALS522 Q inputs	0.1			0.1			mA
	All other inputs	0.1			0.1			
I_{IH}	'ALS518, 'ALS522 Q inputs	-0.2			-0.2			mA
	All other inputs	20			20			
I_{IL}	'ALS518, 'ALS522 Q inputs	-0.6			-0.6			mA
	All other inputs	-0.1			-0.1			
I_{CC}	'ALS518	11			11			mA
	'ALS519	17			17			
	'ALS522	11			17			

[†]All typical values are at $V_{CC} = 5$ V, $T_A = 25$ °C.
NOTE 1: I_{CC} is measured with \bar{G} grounded, P and Q at 4.5 V.

2

ALS AND AS CIRCUITS

**TYPES SN54ALS518, THRU SN54ALS522, SN74ALS518 THRU SN74ALS522
8-BIT IDENTITY COMPARATORS**

'ALS518, 'ALS519 switching characteristics (see Note 1)

PARAMETER	FROM (INPUT)	TO (OUTPUT)	V _{CC} = 4.5 V to 5.5 V, C _L = 50 pF, R _L = 680 Ω, T _A = MIN to MAX				UNIT
			SN54ALS518 SN54ALS519		SN74ALS518 SN74ALS519		
			MIN	MAX	MIN	MAX	
t _{PLH}	P or Q	P = Q	15	37	15	33	ns
t _{PHL}			3	18	3	15	
t _{PLH}	\bar{G}	P = Q	15	37	15	33	ns
t _{PHL}			3	18	3	15	

'ALS522 switching characteristics (see Note 1)

PARAMETER	FROM (INPUT)	TO (OUTPUT)	V _{CC} = 4.5 V to 5.5 V, C _L = 50 pF, R _L = 680 Ω, T _A = MIN to MAX				UNIT
			SN54ALS522		SN74ALS522		
			MIN	MAX	MIN	MAX	
t _{PLH}	P or Q	$\bar{P} = \bar{Q}$	10	30	10	25	ns
t _{PHL}			5	25	5	23	
t _{PLH}	\bar{G}	$\bar{P} = \bar{Q}$	8	30	8	25	ns
t _{PHL}			8	30	8	23	

NOTE 1: For load circuit and voltage waveforms, see page 1-12.

2 ALS AND AS CIRCUITS

TYPES SN54ALS518, THRU SN54ALS522, SN74ALS518 THRU SN74ALS522 8-BIT IDENTITY COMPARATORS

absolute maximum ratings over operating free-air temperature range (unless otherwise noted)

Supply voltage, V_{CC}	7 V
Input voltage: Q inputs of 'ALS520	$V_{CC} + 0.5$ V or 5.5 V, whichever is less
All other inputs	7 V
Operating free-air temperature range: SN54ALS520, SN54ALS521	-55 °C to 125 °C
SN74ALS520, SN74ALS521	0 °C to 70 °C
Storage temperature range	-65 °C to 150 °C

recommended operating conditions

	SN54ALS520			SN74ALS520			UNIT		
	SN54ALS521			SN74ALS521					
	MIN	NOM	MAX	MIN	NOM	MAX			
V_{CC} Supply voltage	4.5	5	5.5	4.5	5	5.5	V		
V_{IH} High-level input voltage	2			2			V		
V_{IL} Low-level input voltage	0.8			0.8			V		
I_{OH} High-level output current	-1			-2.6			mA		
I_{OL} Low-level output current	12			24			mA		
T_A Operating free-air temperature	-55			125			0	70	°C

electrical characteristics over recommended operating free-air temperature range (unless otherwise noted)

PARAMETER	TEST CONDITIONS	SN54ALS520			SN74ALS520			UNIT
		SN54ALS521			SN74ALS521			
		MIN	TYP [†]	MAX	MIN	TYP [†]	MAX	
V_{IK}	$V_{CC} = 4.5$ V, $I_I = -18$ mA	-1.5			-1.5			V
V_{OH}	$V_{CC} = 4.5$ V to 5.5 V, $I_{OH} = -0.4$ mA	$V_{CC} - 2$			$V_{CC} - 2$			V
	$V_{CC} = 4.5$ V, $I_{OH} = -1$ mA	2.4	3.3					
	$V_{CC} = 4.5$ V, $I_{OH} = -2.6$ mA				2.4	3.2		
V_{OL}	$V_{CC} = 4.5$ V, $I_{OL} = 12$ mA	0.25			0.4	0.25		V
	$V_{CC} = 4.5$ V, $I_{OL} = 24$ mA				0.35	0.5		
I_I	'ALS520 Q inputs	$V_{CC} = 5.5$ V, $V_I = 5.5$ V			0.1			mA
	All other inputs	$V_{CC} = 5.5$ V, $V_I = 7$ V			0.1			
I_{IH}	'ALS520 Q inputs	$V_{CC} = 5.5$ V, $V_I = 2.7$ V			-0.2			mA
	All other inputs				20			
I_{IL}	'ALS520 Q inputs	$V_{CC} = 5.5$ V, $V_I = 0.4$ V			-0.6			mA
	All other inputs				-0.1			
I_O^{\ddagger}	$V_{CC} = 5.5$ V, $V_O = 2.25$ V	-30	-112		-30	-112		mA
I_{CC}	'ALS520	12			19	12		mA
	'ALS521	12			19	12		

[†]All typical values are at $V_{CC} = 5$ V, $T_A = 25$ °C.

[‡]The output conditions have been chosen to produce a current that closely approximates one half of the true short-circuit output current, I_{OS} .

NOTE 1: I_{CC} is measured with \bar{G} grounded and P and Q inputs at 4.5 V.

2

ALS AND AS CIRCUITS

**TYPES SN54ALS518 THRU SN54ALS522, SN74ALS518 THRU SN74ALS522
8-BIT IDENTITY COMPARATORS**

switching characteristics (see Note 1)

PARAMETER	FROM (INPUT)	TO (OUTPUT)	$V_{CC} = 4.5 \text{ V to } 5.5 \text{ V,}$ $C_L = 50 \text{ pF,}$ $R_L = 500 \Omega,$ $T_A = \text{MIN to MAX}$				UNIT
			SN54ALS520 SN54ALS521		SN74ALS520 SN74ALS521		
			MIN	MAX	MIN	MAX	
t_{PLH}	P or Q	$\overline{P=Q}$	3	16	3	12	ns
t_{PHL}			5	25	5	20	
t_{PLH}	\overline{G}	$\overline{P=Q}$	2	15	2	12	ns
t_{PHL}			5	23	5	22	

NOTE 1. For load circuit and voltage waveforms, see page 1-12.

2

ALS AND AS CIRCUITS