

Will be replaced by MMG2001NT1 in Q305. N suffix indicates 260°C reflow capable. The PFP-16 package has had lead-free terminations from its initial release.

Gallium Arsenide CATV Integrated Amplifier Module

Features

- Specified for 79-, 112- and 132-Channel Loading
- Excellent Distortion Performance
- Higher Output Capability
- Built-in Input Diode Protection
- GaAs FET Transistor Technology
- Unconditionally Stable Under All Load Conditions
- In Tape and Reel. T1 Suffix = 1,000 Units per 16 mm, 13 inch Reel.

Applications

- CATV Systems Operating in the 40 to 870 MHz Frequency Range
- Output Stage Amplifier in Optical Nodes, Line Extenders and Trunk Distribution Amplifiers for CATV Systems
- Driver Amplifier in Linear General Purpose Applications

Description

- 24 Vdc Supply, 40 to 870 MHz, CATV Integrated Forward Power Doubler Amplifier Module

MMG2001T1

**870 MHz
 21 dB GAIN
 132-CHANNEL
 CATV INTEGRATED AMPLIFIER
 MODULE**

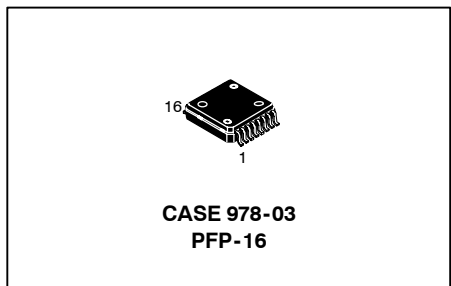

Table 1. Maximum Ratings

Rating	Symbol	Value	Unit
RF Voltage Input (Single Tone)	V_{in}	+70	dBmV
DC Supply Voltage	V_{CC}	+26	Vdc
Operating Case Temperature Range	T_C	-20 to +100	°C
Storage Temperature Range	T_{stg}	-40 to +100	°C

Table 2. Thermal Characteristics

Characteristic	Symbol	Value	Unit
Thermal Resistance, Junction to Case	$R_{\theta JC}$	4.7	°C/W

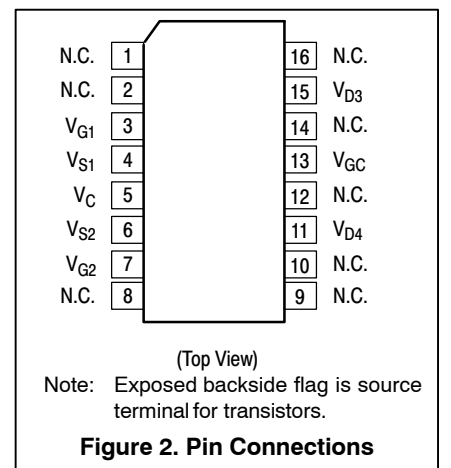
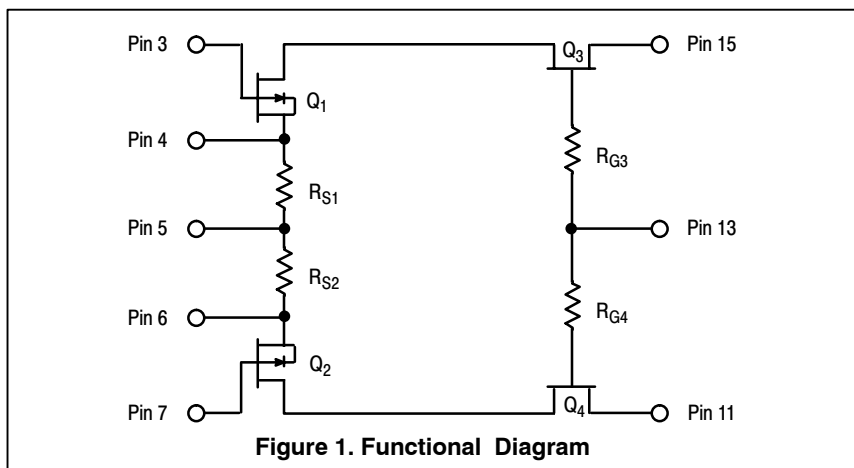

Table 3. ESD Protection Characteristics

Test Conditions	Class
Human Body Model	1 (minimum)
Machine Model	M1 (minimum)
Charge Device Model	C5 (minimum)

Table 4. Moisture Sensitivity Level

Test Methodology	Rating	Package Peak Temperature	Unit
Per JESD 22-A113, IPC/JEDEC J-STD-020	3	260	°C

Table 5. Electrical Characteristics ($V_{CC} = 24$ Vdc, $T_C = +45^\circ\text{C}$, 75 Ω system unless otherwise noted)

Characteristic	Symbol	Min	Typ	Max	Unit	
Frequency Range	BW	40	—	870	MHz	
Power Gain	G_p	—	19	—	dB	
40 MHz		—	21	—		
870 MHz		—	—	—		
Slope	S	—	0.8	—	dB	
Gain Flatness (40 - 870 MHz, Peak to Valley)	G_F	—	0.5	—	dB	
Input Return Loss ($Z_o = 75$ Ohms)	IRL	—	21	—	dB	
f = 40-160 MHz		—	19	—		
f = 161-450 MHz		—	22	—		
Output Return Loss ($Z_o = 75$ Ohms)	ORL	—	22	—	dB	
f = 40-400 MHz		—	17	—		
Composite Second Order					dBc	
($V_{out} = +48$ dBmV/ch., Worst Case)	132-Channel FLAT	CSO_{132}	—	-68		-60
($V_{out} = +48$ dBmV/ch., Worst Case)	112-Channel FLAT	CSO_{112}	—	-70		-62
($V_{out} = +48$ dBmV/ch., Worst Case)	79-Channel FLAT	CSO_{79}	—	-74		-66
($V_{out} = +56$ dBmV @ 870 MHz Equiv)	112-Channel, 12 dB Tilt	CSO_{112}	—	-63		—
($V_{out} = +56$ dBmV @ 870 MHz Equiv)	112-Channel, 13.5 dB Tilt	CSO_{112}	—	-62		—
($V_{out} = +56$ dBmV @ 870 MHz Equiv)	112-Channel, 17 dB Tilt	CSO_{112}	—	-61		—
($V_{out} = +58$ dBmV @ 870 MHz Equiv)	79-Channel, 12 dB Tilt	CSO_{79}	—	-67		—
($V_{out} = +58$ dBmV @ 870 MHz Equiv)	79-Channel, 13.5 dB Tilt	CSO_{79}	—	-72		—
($V_{out} = +58$ dBmV @ 870 MHz Equiv)	79-Channel, 17 dB Tilt	CSO_{79}	—	-71		—
Cross Modulation Distortion @ Ch 2					dBc	
($V_{out} = +48$ dBmV/ch., FM = 55 MHz)	132-Channel FLAT	XMD_{132}	—	-55		-53
($V_{out} = +48$ dBmV/ch., FM = 55 MHz)	112-Channel FLAT	XMD_{112}	—	-57		-55
($V_{out} = +48$ dBmV/ch., FM = 55 MHz)	79-Channel FLAT	XMD_{79}	—	-60		-58
($V_{out} = +56$ dBmV @ 870 MHz Equiv)	112-Channel, 12 dB Tilt	XMD_{112}	—	-51		—
($V_{out} = +56$ dBmV @ 870 MHz Equiv)	112-Channel, 13.5 dB Tilt	XMD_{112}	—	-53		—
($V_{out} = +56$ dBmV @ 870 MHz Equiv)	112-Channel, 17 dB Tilt	XMD_{112}	—	-56		—
($V_{out} = +58$ dBmV @ 870 MHz Equiv)	79-Channel, 12 dB Tilt	XMD_{79}	—	-58		—
($V_{out} = +58$ dBmV @ 870 MHz Equiv)	79-Channel, 13.5 dB Tilt	XMD_{79}	—	-60		—
($V_{out} = +58$ dBmV @ 870 MHz Equiv)	79-Channel, 17 dB Tilt	XMD_{79}	—	-65		—
Composite Triple Beat					dBc	
($V_{out} = +48$ dBmV/ch., Worst Case)	132-Channel FLAT	CTB_{132}	—	-56		-54
($V_{out} = +48$ dBmV/ch., Worst Case)	112-Channel FLAT	CTB_{112}	—	-60		-58
($V_{out} = +48$ dBmV/ch., Worst Case)	79-Channel FLAT	CTB_{79}	—	-66		-64
($V_{out} = +56$ dBmV @ 870 MHz Equiv)	112-Channel, 12 dB Tilt	CTB_{112}	—	-58		—
($V_{out} = +56$ dBmV @ 870 MHz Equiv)	112-Channel, 13.5 dB Tilt	CTB_{112}	—	-59		—
($V_{out} = +56$ dBmV @ 870 MHz Equiv)	112-Channel, 17 dB Tilt	CTB_{112}	—	-62		—
($V_{out} = +58$ dBmV @ 870 MHz Equiv)	79-Channel, 12 dB Tilt	CTB_{79}	—	-64		—
($V_{out} = +58$ dBmV @ 870 MHz Equiv)	79-Channel, 13.5 dB Tilt	CTB_{79}	—	-69		—
($V_{out} = +58$ dBmV @ 870 MHz Equiv)	79-Channel, 17 dB Tilt	CTB_{79}	—	-72		—
Noise Figure	NF	—	4.0	4.5	dB	
50 MHz		—	4.0	4.5		
550 MHz		—	4.0	4.5		
750 MHz		—	4.0	4.5		
870 MHz		—	4.0	4.5		
DC Current ($V_{DC} = 24$ V, $T_C = 45^\circ\text{C}$)	I_{DC}	410	425	440	mA	

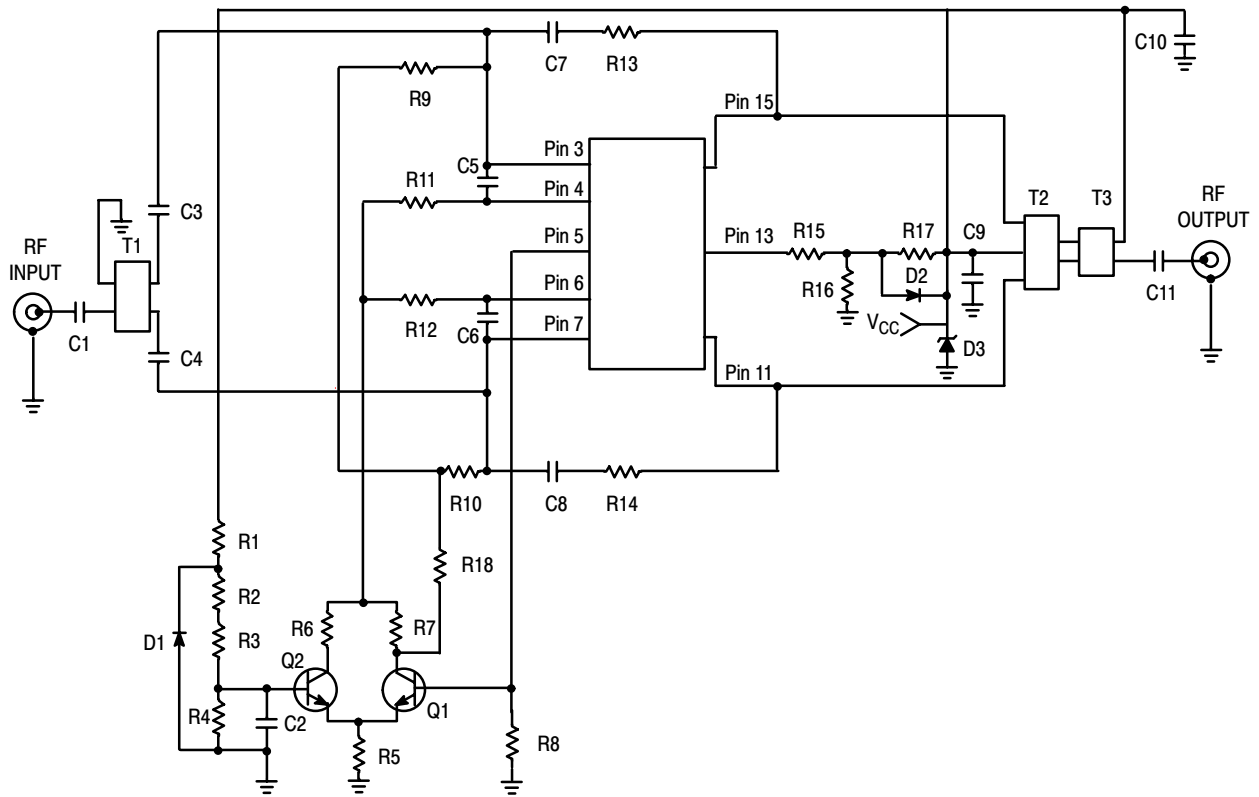
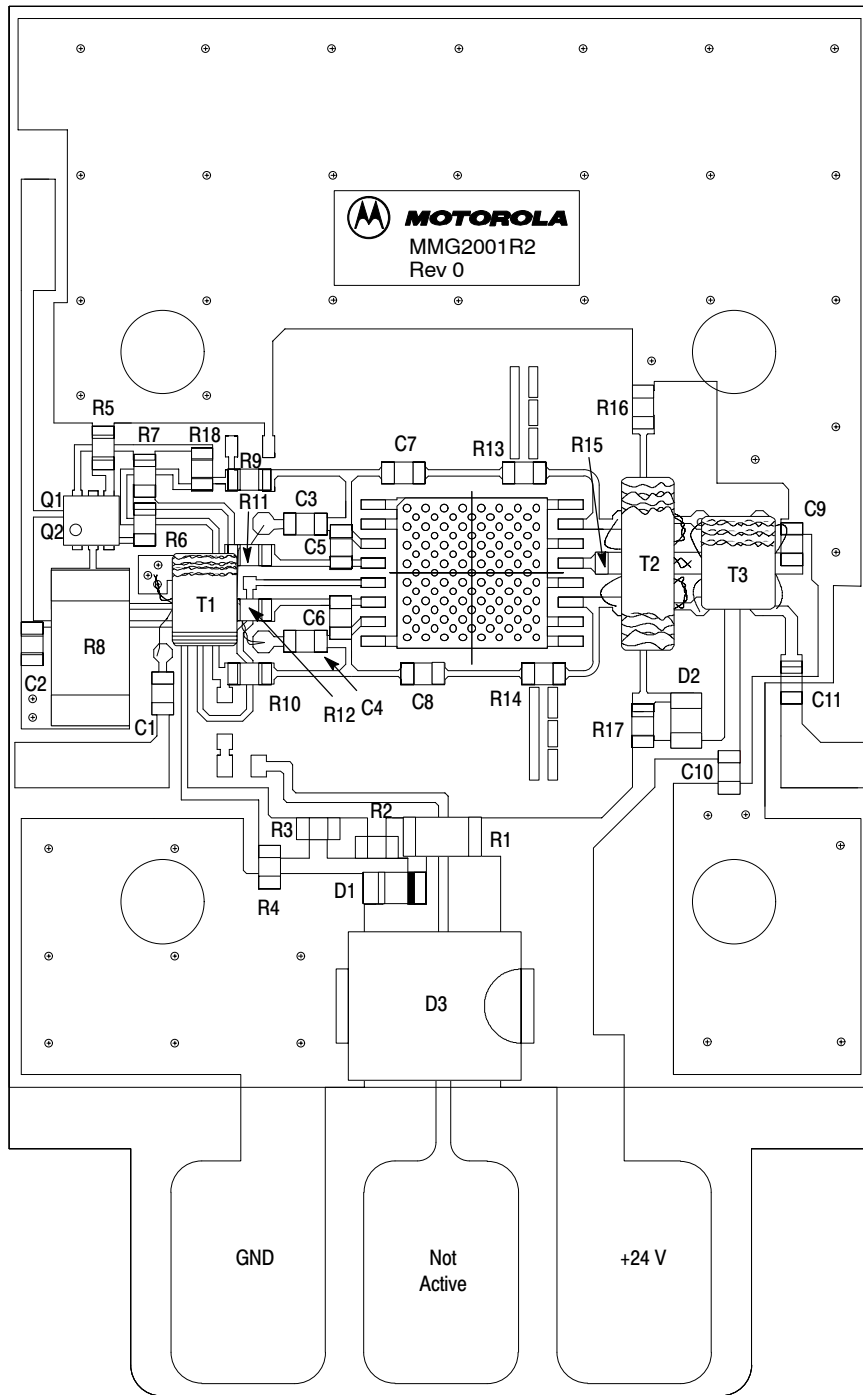

Figure 3. MMG2001T1 50-870 MHz Test Circuit Schematic

Table 6. MMG2001T1 50-870 MHz Test Circuit Component Designations and Values

Designation	Description
C1, C7, C8, C11	220 pF Chip Capacitors (0603)
C2, C3, C4, C9, C10	0.01 μ F Chip Capacitors (0603)
C5, C6	1.8 pF Chip Capacitors (0603)
D1	5.1 V Zener Diode, On/MM3Z5V1T1
D2	27 V Zener Diode, On/MM3Z27VT1
D3	Transient Voltage Suppressor, On/1.5k27A/1.5SMC27AT3
Q1, Q2	Dual Transistors Package, On/MBT3904DW1T1
R1	2.2 k Ω , 1/4 W Chip Resistor (1206)
R2	680 Ω Chip Resistor (0603)
R3	180 Ω Chip Resistor (0603)
R4	1600 Ω Chip Resistor (0603)
R5	820 Ω Chip Resistor (0603)
R6	120 Ω Chip Resistor (0603)
R7	1.5 k Ω Chip Resistor (0603)
R8	8 Ω , 1 W Chip Resistor (2512)
R9, R10, R15	470 Ω Chip Resistors (0603)
R11, R12	18 Ω Chip Resistors (0603)
R13, R14	680 Ω Chip Resistors (0603)
R16	2.4 k Ω Chip Resistor (0603)
R17	6.2 k Ω Chip Resistor (0603)
R18	0 Ω Chip Resistor (0603)
T1	Input Transformer, 77PC016E080
T2	Output Transformer, 77PC016E071
T3	Output Transformer, 77PC016E072
PCB	FR4, 62 mil, $\epsilon_r = 4.81$



Freescale has begun the transition of marking Printed Circuit Boards (PCBs) with the Freescale Semiconductor signature/logo. PCBs may have either Motorola or Freescale markings during the transition period. These changes will have no impact on form, fit or function of the current product.

Figure 4. MMG2001T1 50-870 MHz Test Circuit Component Layout

TYPICAL CHARACTERISTICS

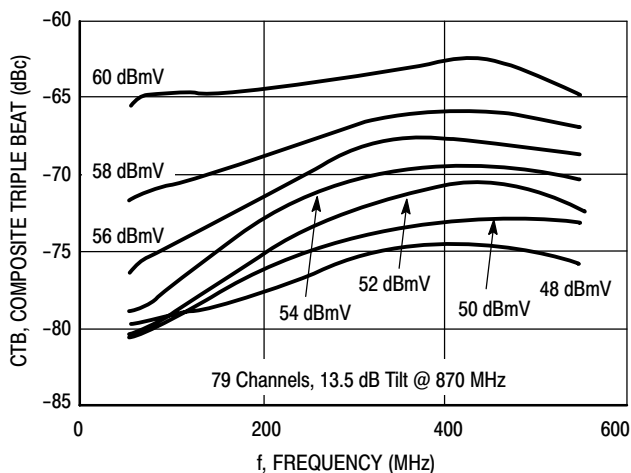

Figure 5. Composite Triple Beat versus Frequency

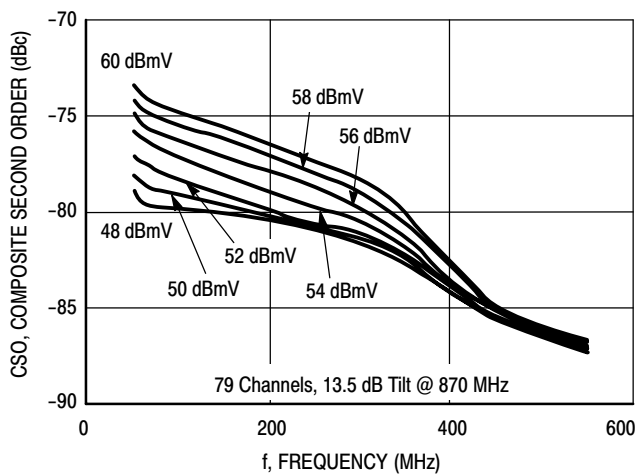

Figure 6. Composite Second Order versus Frequency

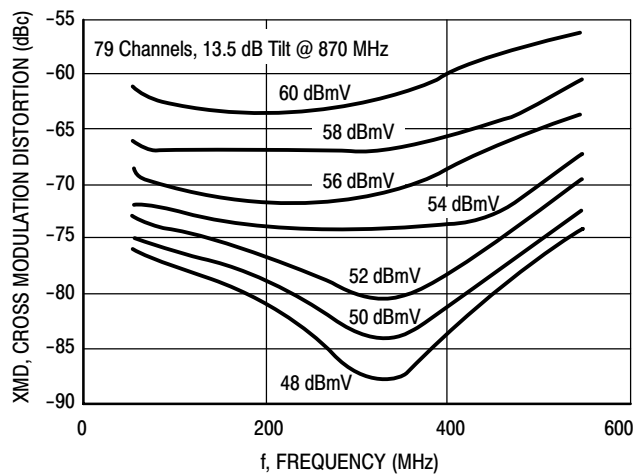
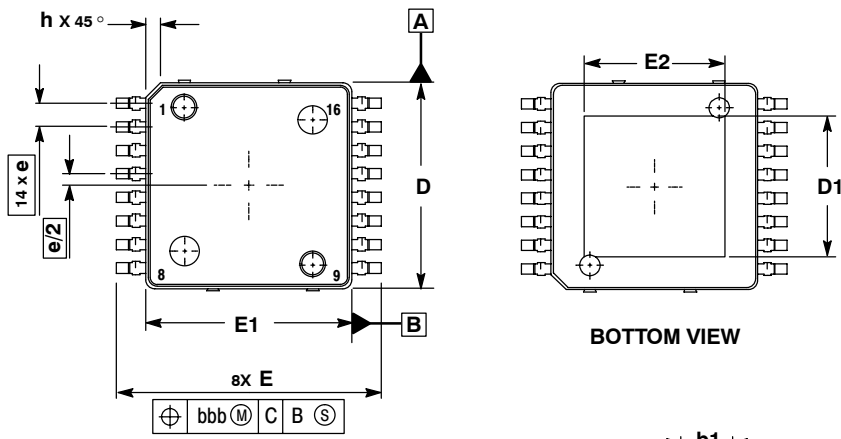

Figure 7. Cross Modulation Distortion versus Frequency



NOTES

PACKAGE DIMENSIONS



BOTTOM VIEW

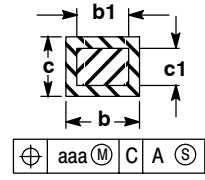
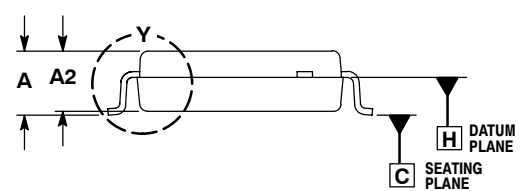

SECT W-W

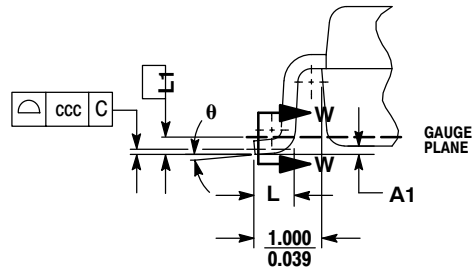

DETAIL Y

NOTES:

1. CONTROLLING DIMENSION: MILLIMETER.
2. DIMENSIONS AND TOLERANCES PER ASME Y14.5M, 1994.
3. DATUM PLANE -H- IS LOCATED AT BOTTOM OF LEAD AND IS COINCIDENT WITH THE LEAD WHERE THE LEAD EXITS THE PLASTIC BODY AT THE BOTTOM OF THE PARTING LINE.
4. DIMENSIONS D AND E1 DO NOT INCLUDE MOLD PROTRUSION. ALLOWABLE PROTRUSION IS 0.250 PER SIDE. DIMENSIONS D AND E1 DO INCLUDE MOLD MISMATCH AND ARE DETERMINED AT DATUM PLANE -H-.
5. DIMENSION b DOES NOT INCLUDE DAMBAR PROTRUSION. ALLOWABLE DAMBAR PROTRUSION IS 0.127 TOTAL IN EXCESS OF THE b DIMENSION AT MAXIMUM MATERIAL CONDITION.
6. DATUMS -A- AND -B- TO BE DETERMINED AT DATUM PLANE -H-.

DIM	MILLIMETERS	
	MIN	MAX
A	2.000	2.300
A1	0.025	0.100
A2	1.950	2.100
D	6.950	7.100
D1	4.372	5.180
E	8.850	9.150
E1	6.950	7.100
E2	4.372	5.180
L	0.466	0.720
L1	0.250 BSC	
b	0.300	0.432
b1	0.300	0.375
c	0.180	0.279
c1	0.180	0.230
e	0.800 BSC	
h	---	0.600
θ	0°	7°
aaa	0.200	
bbb	0.200	
ccc	0.100	

**CASE 978-03
ISSUE C
PFP-16**

How to Reach Us:

Home Page:

www.freescale.com

E-mail:

support@freescale.com

USA/Europe or Locations Not Listed:

Freescale Semiconductor
Technical Information Center, CH370
1300 N. Alma School Road
Chandler, Arizona 85224
+1-800-521-6274 or +1-480-768-2130
support@freescale.com

Europe, Middle East, and Africa:

Freescale Halbleiter Deutschland GmbH
Technical Information Center
Schatzbogen 7
81829 Muenchen, Germany
+44 1296 380 456 (English)
+46 8 52200080 (English)
+49 89 92103 559 (German)
+33 1 69 35 48 48 (French)
support@freescale.com

Japan:

Freescale Semiconductor Japan Ltd.
Headquarters
ARCO Tower 15F
1-8-1, Shimo-Meguro, Meguro-ku,
Tokyo 153-0064
Japan
0120 191014 or +81 3 5437 9125
support.japan@freescale.com

Asia/Pacific:

Freescale Semiconductor Hong Kong Ltd.
Technical Information Center
2 Dai King Street
Tai Po Industrial Estate
Tai Po, N.T., Hong Kong
+800 2666 8080
support.asia@freescale.com

For Literature Requests Only:

Freescale Semiconductor Literature Distribution Center
P.O. Box 5405
Denver, Colorado 80217
1-800-441-2447 or 303-675-2140
Fax: 303-675-2150
LDCForFreescaleSemiconductor@hibbertgroup.com

RoHS-compliant and/or Pb-free versions of Freescale products have the functionality and electrical characteristics of their non-RoHS-compliant and/or non-Pb-free counterparts. For further information, see <http://www.freescale.com> or contact your Freescale sales representative.

For information on Freescale's Environmental Products program, go to <http://www.freescale.com/epp>.

Information in this document is provided solely to enable system and software implementers to use Freescale Semiconductor products. There are no express or implied copyright licenses granted hereunder to design or fabricate any integrated circuits or integrated circuits based on the information in this document.

Freescale Semiconductor reserves the right to make changes without further notice to any products herein. Freescale Semiconductor makes no warranty, representation or guarantee regarding the suitability of its products for any particular purpose, nor does Freescale Semiconductor assume any liability arising out of the application or use of any product or circuit, and specifically disclaims any and all liability, including without limitation consequential or incidental damages. "Typical" parameters that may be provided in Freescale Semiconductor data sheets and/or specifications can and do vary in different applications and actual performance may vary over time. All operating parameters, including "Typicals", must be validated for each customer application by customer's technical experts. Freescale Semiconductor does not convey any license under its patent rights nor the rights of others. Freescale Semiconductor products are not designed, intended, or authorized for use as components in systems intended for surgical implant into the body, or other applications intended to support or sustain life, or for any other application in which the failure of the Freescale Semiconductor product could create a situation where personal injury or death may occur. Should Buyer purchase or use Freescale Semiconductor products for any such unintended or unauthorized application, Buyer shall indemnify and hold Freescale Semiconductor and its officers, employees, subsidiaries, affiliates, and distributors harmless against all claims, costs, damages, and expenses, and reasonable attorney fees arising out of, directly or indirectly, any claim of personal injury or death associated with such unintended or unauthorized use, even if such claim alleges that Freescale Semiconductor was negligent regarding the design or manufacture of the part.

Freescale™ and the Freescale logo are trademarks of Freescale Semiconductor, Inc. All other product or service names are the property of their respective owners.

© Freescale Semiconductor, Inc. 2005. All rights reserved.

