

To all our customers

---

## **Regarding the change of names mentioned in the document, such as Mitsubishi Electric and Mitsubishi XX, to Renesas Technology Corp.**

---

The semiconductor operations of Hitachi and Mitsubishi Electric were transferred to Renesas Technology Corporation on April 1st 2003. These operations include microcomputer, logic, analog and discrete devices, and memory chips other than DRAMs (flash memory, SRAMs etc.) Accordingly, although Mitsubishi Electric, Mitsubishi Electric Corporation, Mitsubishi Semiconductors, and other Mitsubishi brand names are mentioned in the document, these names have in fact all been changed to Renesas Technology Corp. Thank you for your understanding. Except for our corporate trademark, logo and corporate statement, no changes whatsoever have been made to the contents of the document, and these changes do not constitute any alteration to the contents of the document itself.

Note : Mitsubishi Electric will continue the business operations of high frequency & optical devices and power devices.

Renesas Technology Corp.  
Customer Support Dept.  
April 1, 2003

# M62260FP

CS / BS CONVERTER DRIVER IC

## DESCRIPTION

M62260FP is developed to be a 2-channel HEMT driver.

Capable of simplifying the peripheral circuits, this IC permits compact unitized design.

Incorporating in itself two power sources, +8V with high stability and great current capacity and -3.2V with simple construction, and the protective circuit designed to be actuated in the event of output overload or short, the IC has no restrictions to its applications.

## FEATURES

- Sole connection of small-capacity power transistors permits the construction of a power source system, and therefore it is possible to produce low-cost sets with a small number of parts.
- The "L" shape protective circuit used as the over-current limiting circuit prevents heat generation and destruction in the event of output short.
- Since the high-precision +8V power source is arranged as pre-drive, sole connection of external transistors permits current output in the magnitude of  $h_{FE}$  times 30 mA.  
(when  $h_{FE}=50$ , the resulting maximum current is 1.5 A.)  
Since the power source can serve as a low dropout power source as well, even low line voltage such as a minimum of  $V_o + 0.5V$  provides normal operation.
- The package is small with 14 pins.
- The use of voltage adjustment terminals permits external adjustment of output voltage.

## PIN CONFIGURATION (TOP VIEW)



Outline 14P2P-A

## APPLICATION

CS and BS converters and the like

## BLOCK DIAGRAM

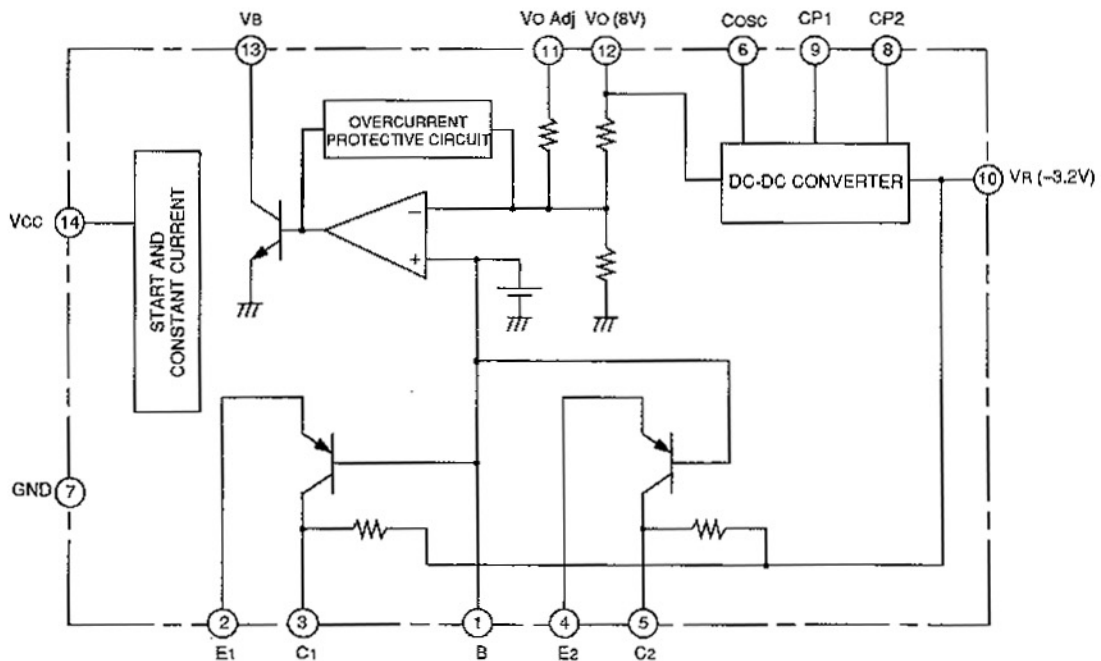

## EXPLANATION OF TERMINALS

Pin No.	Symbol	Function
①	B	HEMT driving PNP transistor base output(reference voltage output)
②	E1	HEMT driving PNP transistor emitter output 1
③	C1	HEMT driving gate bias output 1
④	E2	HEMT driving PNP transistor emitter output 2
⑤	C2	HEMT driving gate bias output 2
⑥	Cosc	DC-DC converter oscillation circuit capacitor connection terminal
⑦	GND	GND terminal
⑧	CP2	Charge pump capacitor connection terminal
⑨	CP1	Charge pump capacitor connection terminal
⑩	VR	Negative output voltage terminal
⑪	VOADJ	Positive and negative output voltage adjustment terminal
⑫	Vo	Positive output voltage terminal
⑬	V <sub>B</sub>	External transistor base drive terminal
⑭	V <sub>CC</sub>	Power supply terminal

## ABSOLUTE MAXIMUM RATINGS (Ta = 25°C, unless otherwise noted)

Symbol	Parameter	Conditions	Ratings	Unit
V <sub>CC</sub>	Supply voltage		23	V
P <sub>d</sub>	Power dissipation		550	mW
K <sub>θ</sub>	Thermal derating	Ta>=25°C	5.5	mW/°C
T <sub>opr</sub>	Operating temperature		-30~+85	°C
T <sub>stg</sub>	Storage temperature		-55~+125	°C

ELECTRICAL CHARACTERISTICS (V<sub>CC</sub> = 12 V, Ta = 25°C, unless otherwise noted)

Symbol	Parameter	Test conditions	Limits			Unit
			Min	Typ	Max	
V <sub>CC</sub>	Supply voltage		Vo+0.5		22	V
I <sub>CC</sub>	Circuit current			10	15	mA
I <sub>Bmax</sub>	MAXIMUM Bias current		10	30		mA
Vo	Positive output voltage	In steady state (VoAdj : open)	7.6	8.0	8.4	V
		VoAdj-Vo terminal short	4.75	5.0	5.25	
VR	Negative output voltage	In steady state (VoAdj : open)	-4.0	-3.2	-2.4	V
		VoAdj-Vo terminal short	-2.5	-2.0	-1.5	
V <sub>I</sub>	Reference voltage		2.38	2.5	2.62	V
I <sub>BSC</sub>	Positive output short bias current			1		mA
Reg-in	Positive output input regulation	V <sub>CC</sub> =8.5V~22V		0.02		%/V
Reg-lo	Positive output load regulation	I <sub>o</sub> =10mA~100mA		20		mV
VoN	Positive output noise voltage	BPF:10Hz~100kHz, I <sub>o</sub> =100mA		170	300	μVrms
R <sub>r</sub>	Positive output ripple removal ratio		40	60		dBm
ΔVo/ΔT	Positive output voltage temperature coefficient			0.02		%/T
⊖ Reg-lo	Negative output load regulation	I <sub>R</sub> = 0.5mA~3mA		0.6	0.9	V
ΔVR/ΔT	Negative output voltage temperature coefficient			0.02		%/T
ΔVR	Negative output ripple voltage	I <sub>R</sub> =0		20	30	mV
ΔVo	Positive output clock leak voltage	I <sub>L</sub> =0		10	20	mV

**M62260FP**

**CS / BS CONVERTER DRIVER IC**

**APPLICATION EXAMPLE**

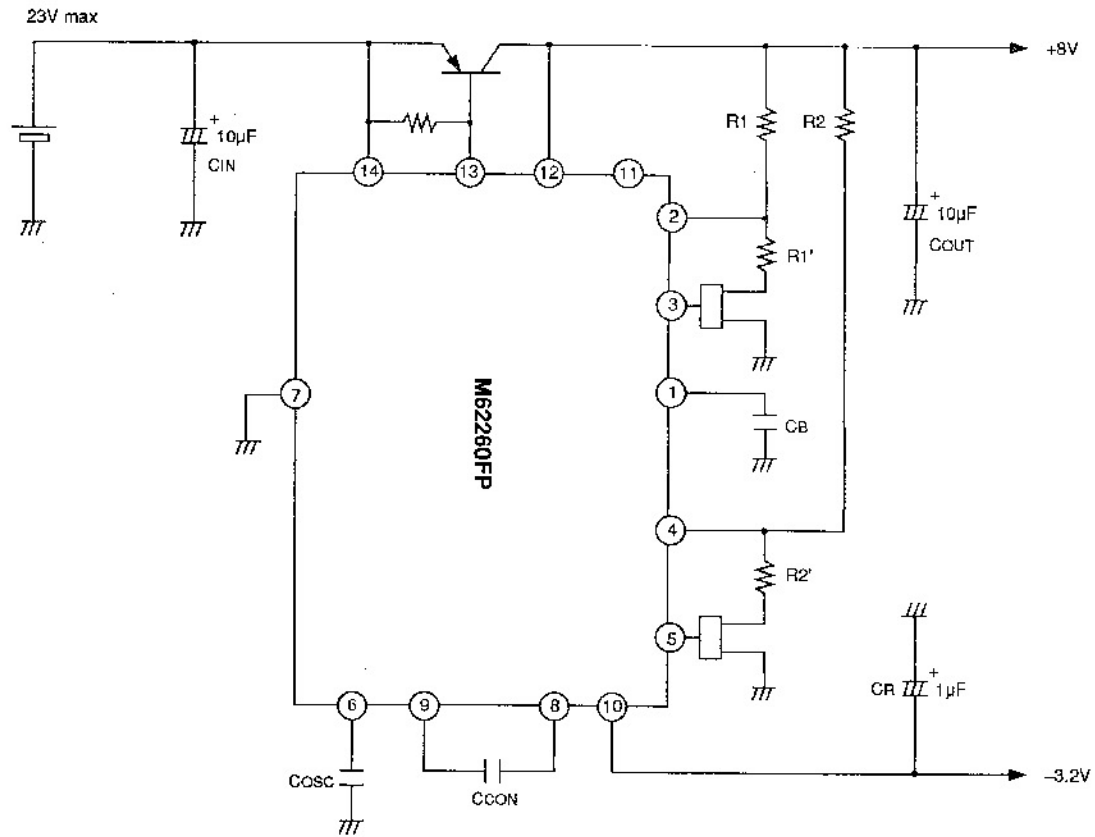

\* R1' and R2' are required for VDS adjustment.

**VOAdj terminal (pin ⑪)**

This terminal is the adjustment terminal for Vo, VR.  
 Insertion of an adjustment resistor between pins ⑪, ⑫, as shown in the diagram at right, permits adjustment in the range of  $5V \leq V_o \leq 8V$ .

(When pins ⑪, ⑫ are shorted,  $V_o = 5V$ )

VR changes according to Vo setting.

$V_R = -0.4V_o$  (V)

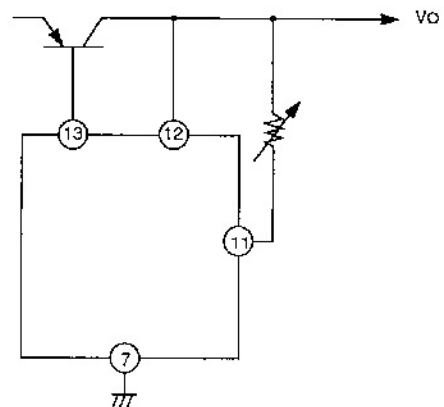

HEMT BIAS CIRCUIT

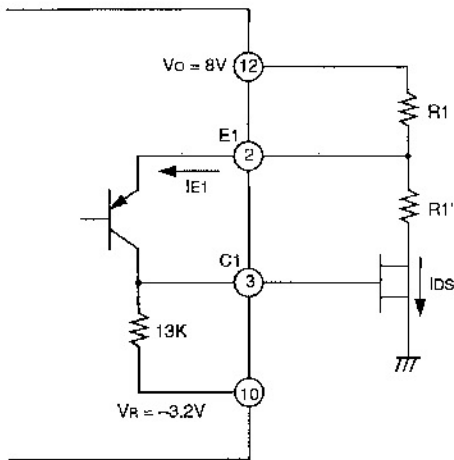

- $R1 = (V_o - V_B + V_{BE}) / (I_{DS} + I_{E1})$ ,  $R1' = (V_B + V_{BE} - V_{DS}) / I_{DS}$   
 $(V_o = 8V, V_B = 2.5V, V_{BE} = 0.7V, I_{DS} = 10mA, V_{DS} = 2V, I_{E1} = 0.23mA)$   
 $R1 = (8V - 2.5V + 0.7V) / (10mA + 0.23mA)$   
 $= 4.8V / 10.23mA$   
 $R1 \approx 470\Omega$
- $R1' = (2.5V + 0.7V - 2V) / 10mA$   
 $= 1.2V / 10mA$   
 $R1' \approx 120\Omega$
- $V_{GS} = I_{E1} \cdot 13K - 3.2V$   
 $= 2.99V - 3.2V$   
 $V_{GS} = -0.21V$   
 $R1 \approx 470\Omega, R1' \approx 120\Omega, V_{GS} = -0.21V$

Example application to limit the maximum bias current.

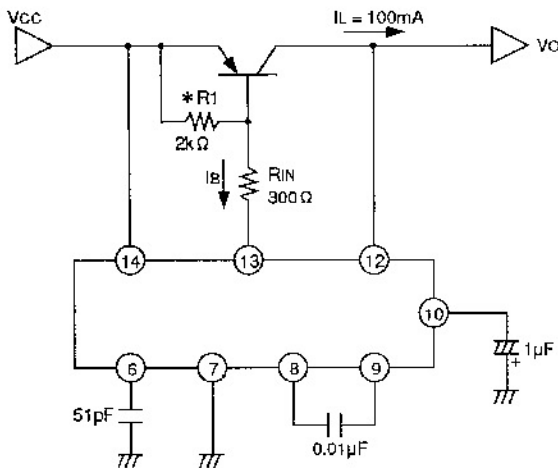

\* R1 should be between 700Ω ~ 6kΩ

When the input voltage ( $V_{CC}$ ) is lower than the set output voltage ( $V_o$ ), approx. 30 ~ 45mA bias current flows through pin ⑬ of the IC (see the bias current-line voltage characteristics diagram).

Insertion of a resistor,  $R_{IN}$ , as needed such as when the bias current need be limited, permits limiting the bias current (see Fig. 1 for the line voltage dependence of the input resistance,  $R_{IN}$  and the limited current.)

In this applied circuit, the current flowing through pin ⑬ is limited to approx. 20 mA when the line voltage ( $V_o$ ) is 8V.

Fig. 2 presents the bias current vs. line voltage characteristics of this applied circuit.

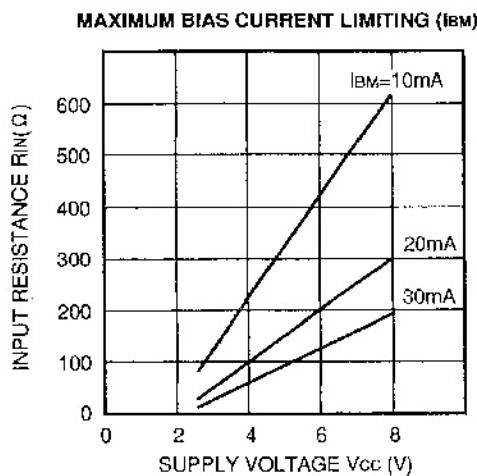

Fig. 1

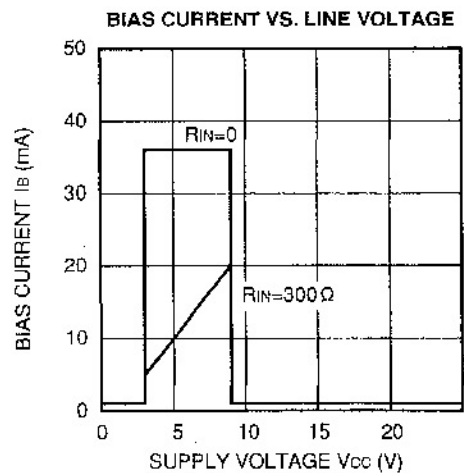

Fig. 2

# M62260FP

## CS / BS CONVERTER DRIVER IC

- DC-DC converter oscillation frequency setting equation.

$$f = \frac{1}{26 \times 10^3 \cdot C_{osc} + 1 \times 10^{-6}} \text{ [Hz]}$$

(Example C<sub>osc</sub>-C<sub>con</sub> ratio)

C <sub>osc</sub> (PF)	C <sub>con</sub> (μF)	f (kHz)
500	0.1	90
100	0.022	333
50	0.01	500

- Setting on the capacitors (C<sub>osc</sub>, C<sub>con</sub>) to produce negative power source (V<sub>R</sub>).

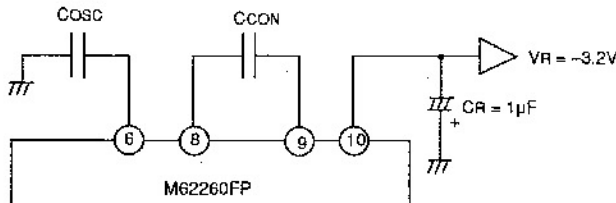

SET THE C<sub>osc</sub>-C<sub>con</sub> RATIO TO 1: 200 OR GREATER.

### TYPICAL CHARACTERISTICS

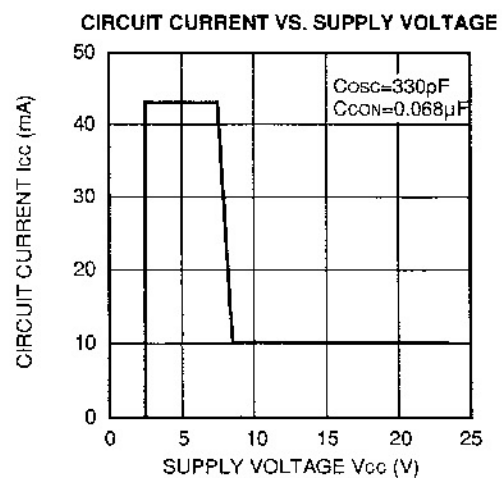
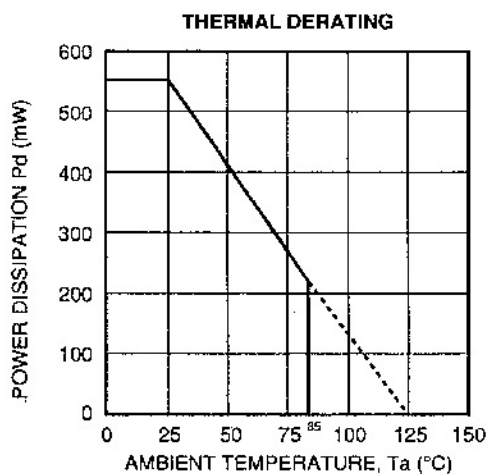
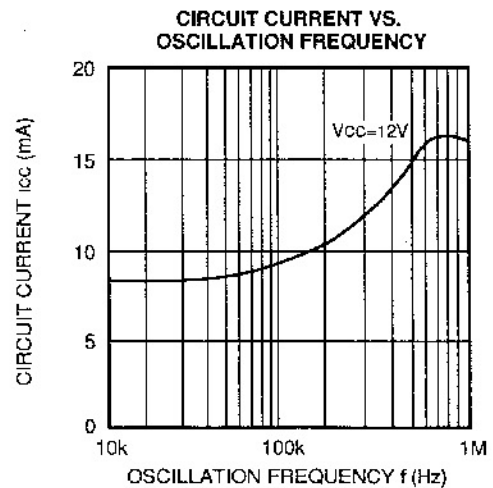
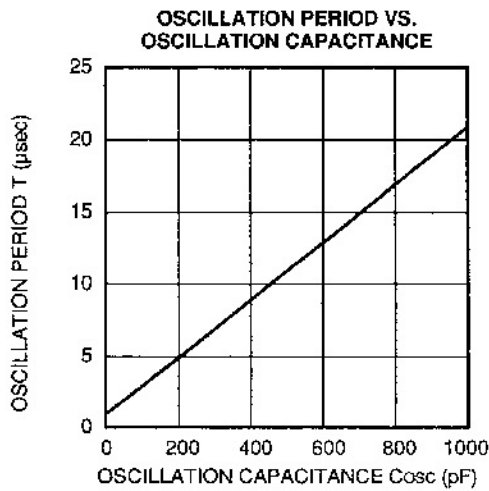

M62260FP

CS / BS CONVERTER DRIVER IC

