

FEATURES

- A complete SONET/SDH Transmitter & Receiver
- Complies with Bellcore, ITU/CCITT and ANSI specifications
- Two on-chip PLLs: One for clock generation & another for clock recovery
- SONET 622.08 Mbit/sec data rates (OC-12)
- Reference frequency of 19.44MHz, 51.84MHz or 77.76MHz
- Compatible with optic modules with and without on-board clock recovery
- TTL/CMOS-compatible parallel I/O
- Differential PECL high-speed serial I/O
- Single +5 volt power supply
- Lock Detect & Frame Detect output
- Typical power dissipation of only 2.8 watts
- Seamless operation with PMC-Sierra's PM5355 S/UNI-622
- Backward compatible with SY69712
- New improved OOF circuitry
- Available in compact 100-pin thermally enhanced QFP package

DESCRIPTION

Synergy's SY69712A Transceiver with integrated clock recovery contains a fully-integrated SONET OC-12 (622.08 Mbit/s) interface circuit. This device performs all necessary serial-to-parallel and parallel-to-serial conversions per SONET and SDH standards. The SY69712A is manufactured in Synergy's high-performance, highly reliable ASSET technology. It is ideally suited for SONET-based ATM applications.

On-chip clock generation is performed by a low-jitter phase-locked loop (PLL), allowing use of the 19.44MHz, 51.84MHz or 77.76MHz clock as a reference. Clock recovery is performed by synchronizing the on-chip VCO directly to the incoming data stream. The SY69712A can also perform SONET/SDH frame detection and alignment on the input data stream.

Compliance with the bit-error rate requirements of the Bellcore, ITU/CCITT and ANSI standards is ensured by Synergy's advanced PLL technology and Positive-ECL (PECL) I/O.

BLOCK DIAGRAM

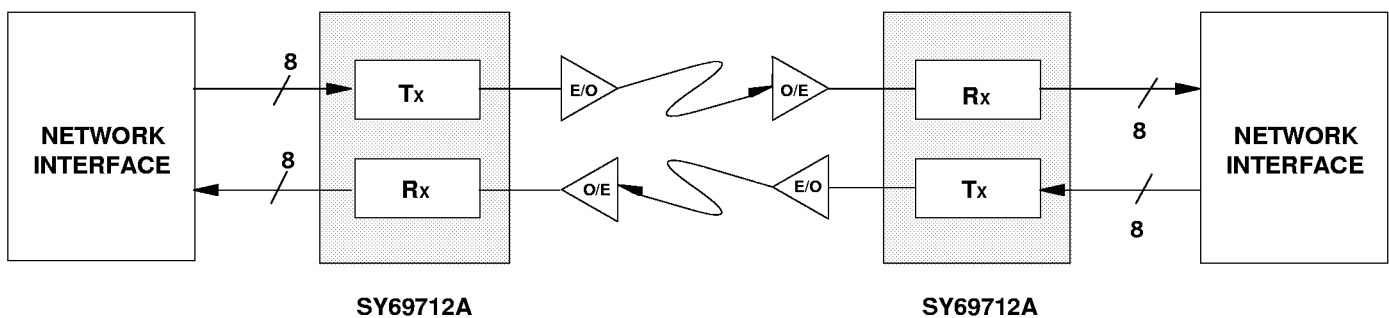

FUNCTIONAL BLOCK DIAGRAM

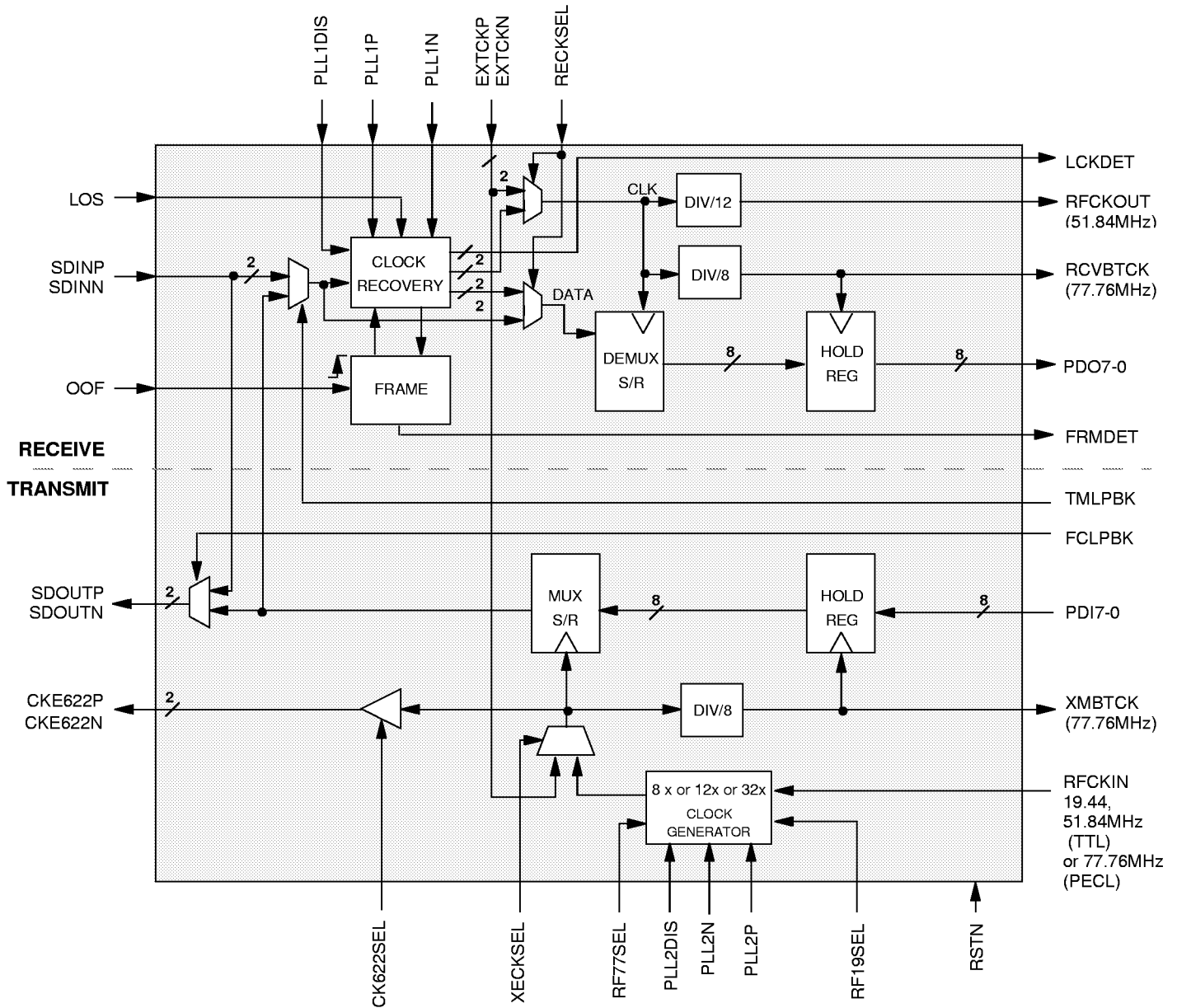

SYSTEM CONNECTION DIAGRAM

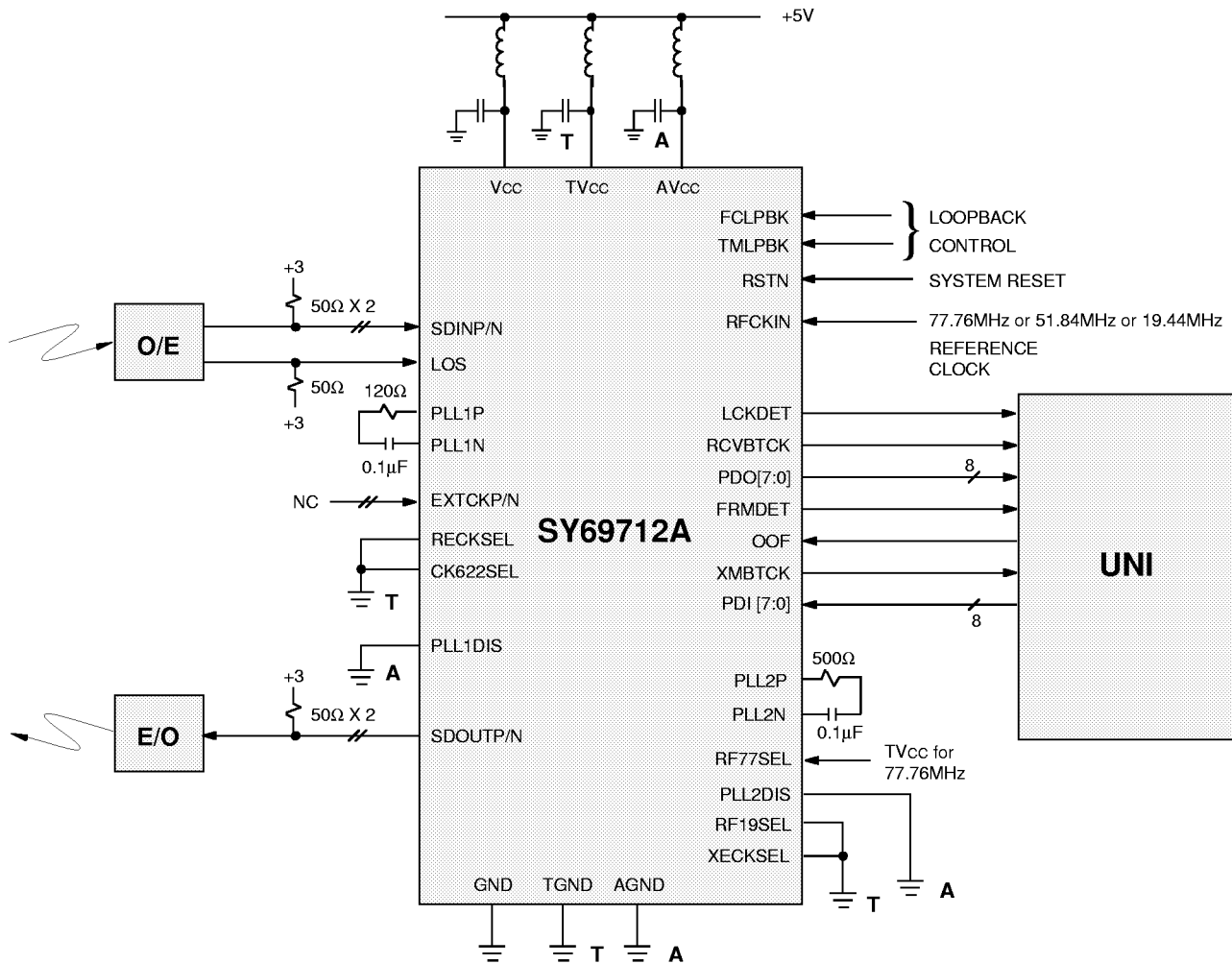

PINOUT

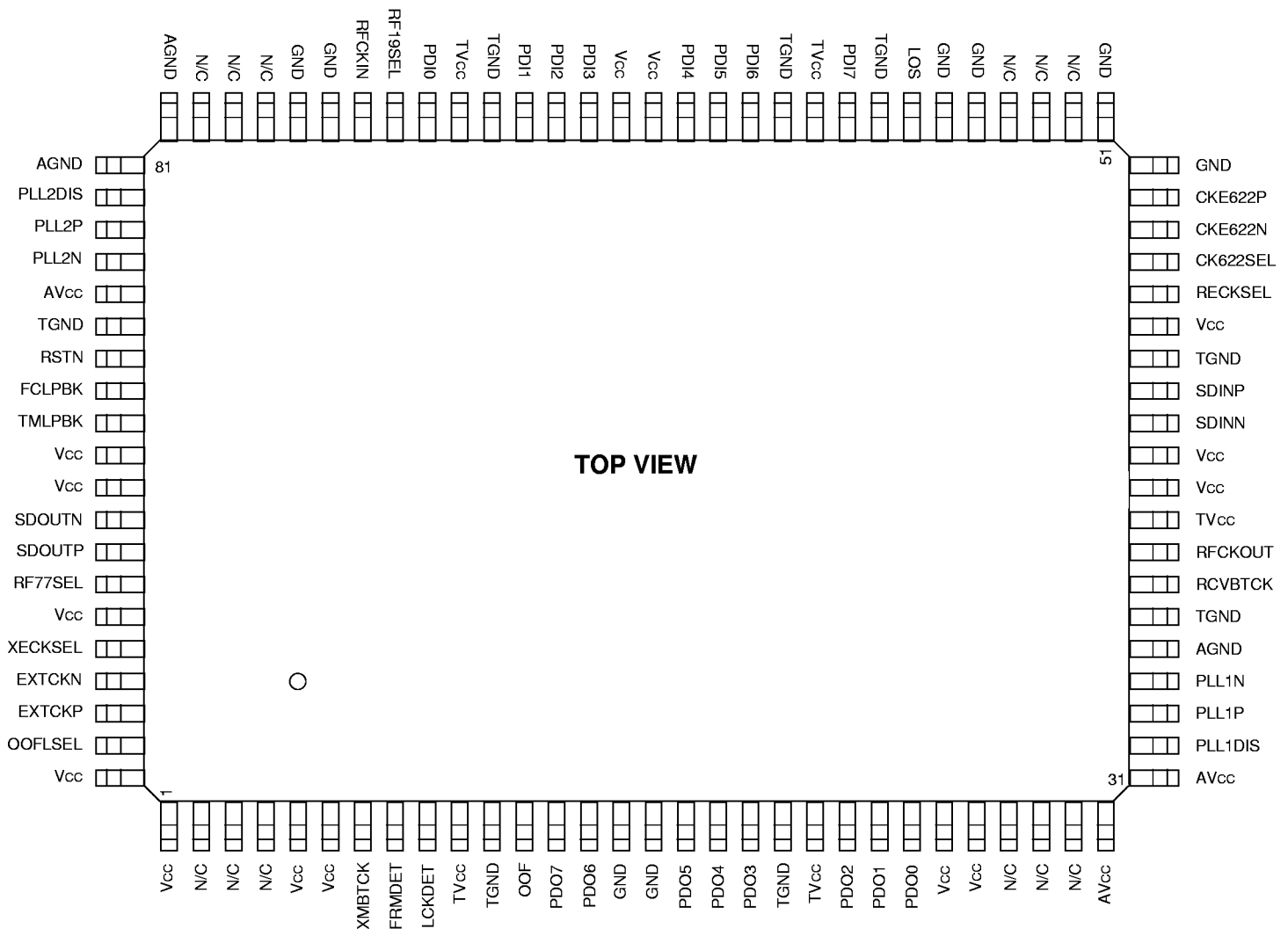

PIN NAMES

INPUTS

SDINP, SDINN [Serial Data Input] Differential PECL.
These pins are normally connected to the optical receiver module. Clock is recovered from the transitions on the SDINP and SDINN inputs.

PDI[7:0] [Parallel Data Input] TTL.
A 77.76 Mbyte/s word aligned to the XMBTCK transmit byte clock. PDI7 is the most significant bit (corresponding to bit 1 of each PCM word, the first bit transmitted). PDI[7:0] is sampled on the rising edge of XMBTCK.

OOF [Out Of Frame Input] TTL.
The OOF interface has been changed to be directly compatible with systems implementing OOF as a level-sensitive signal, such as the PMC-Sierra PM5355, without requiring any external circuitry. This change only affects how the OOF input will initiate Frame Recovery and does not change the way the Frame Detection is implemented. The timing of the FRMDET and Parallel Data Outputs (PDO [7:0]) remains unchanged.

OOF will initiate Frame Recovery (Byte Alignment) after a rising edge on OOF is detected. The duration of OOF can be a positive going pulse with a minimum width of one RCVBTCK period or it can be a high level. In either case, Frame Recovery will be enabled until the first valid 48-bit framing sequence is detected (A1-A1-A1-A2-A2-A2) and a Frame pulse is generated.

PIN NAMES (contd.)

Once this sequence is detected, Frame Recovery is disabled, but Frame Detection remains enabled. Therefore any subsequent 48-bit framing sequence, as long as it is byte-aligned with the initial framing sequence, will be detected and cause a FRMDDET pulse to be generated.

If the first 48-bit sequence is a mimic frame and OOF is never lowered (remains as a high level), then the SY69712A will re-enable Frame Recovery after two frame times have elapsed (>250μs). This will continue as long as OOF is held high.

The SY69712A does not require any external circuitry with the OOF input and will be compatible with any implementation using the current SY69712.

OOFSEL [Out of Frame Level] TTL.

This input is no longer necessary and will be treated as a don't care input since the OOF input has been revised. This pin should not remain floating, either tied to Vcc or GND

RFCKIN [Reference Clock Input] TTL/PECL.

Input normally used to generate the XMBTCK. This signal is also used to generate the 'training' frequency for the clock recovery circuit to keep it centered at 622.08MHz in the absence of data coming in on the SDINP, SDINN inputs. The RFCKIN can be either 19.44MHz, 51.84MHz (TTL) or 77.76MHz (PECL, single-ended) and can be selected with RF19SEL and RF77SEL.

RF77SEL [Reference Clock High Frequency Select Input] TTL.

A low lets the SY69712A default to the RF19SEL pin to determine if this input frequency is 19.44MHz or 51.84MHz. If this pin is high, then the SY69712A will be set for a 77.76MHz (PECL, single-ended) input frequency.

RF19SEL [Reference Clock Select Input] TTL.

Signal used to select the RFCKIN frequency. A high selects 19.44MHz as the Reference Clock and a low selects 51.84MHz as the Reference Clock. A 51.84MHz or 77.76MHz reference clock should be used in SONET applications.

LOS [Loss of Signal] PECL.

A single-ended active high input to be driven by the external optical receiver module to indicate a loss of received optical power. When LOS is high, the data on the Serial Data Input (SDINP, SDINN) pin will be internally forced to a constant low (zero), LCKDET forced low, and the clock recovery PLL forced to lock to the 622.08MHz clock generated from the RFCKIN. When LOS is low, data on the SDINP, SDINN pins will be processed normally.

TMLPBK [Terminal Loopback] TTL. (Active Low)

Selects terminal loopback diagnostic mode. When TMLPBK is low, the parallel data presented on PDI[7:0] is looped back via the serial receive side and presented back on the PDO[7:0] along with the recovered clock. Should be high for normal operation.

FCLPBK [Facility Loopback] TTL. (Active Low)

Selects facility loopback diagnostic mode. When FCLPBK is low, the serial data coming on the SDINP, SDINN pins is routed out via the SDOUTP, SDOUTN pins. Should be high for normal operation.

RSTN [Master Reset] TTL. (Active Low)

An active low signal that resets the device. Frame detection is disabled after master reset. RSTN must be low for 1 millisecond minimum. Should be HIGH for normal operation.

PLL1N, PLL1P [Loop Filter 1]

Loop filter pins for the clock recovery PLL.

PLL2N, PLL2P [Loop Filter 2]

Loop filter pins for the clock synthesis PLL.

PLL1DIS, PLL2DIS [PLL Disable] TTL.

Normally connected to AGND these inputs can be used to disable the respective PLLs for test purposes. These are active high inputs. i.e. a high on PLL1DIS will disable the clock recovery PLL.

CK622SEL [622.08MHz Clock Out Select] TTL.

A high on this pin will present the external 622.08MHz clock on the CK622P and CK622N pins. A low disables the output and minimizes noise.

XECKSEL [Transmit External Clock Select] TTL.

A high on this pin allows the EXTCKP and EXTCKN inputs to be used as the 622.08MHz transmit clock. This is tied to TGND for normal (internal clock recovery) operation.

RECKSEL [Receive External Clock Select] TTL.

A high on this pin allows the EXTCKP and EXTCKN inputs to be used as recovered clock inputs. This makes it possible to use this device with optical receiver modules that provide on-board clock recovery. This is tied to TGND for normal (internal clock recovery) operation.

EXTCKP, EXTCKN [External 622.08MHz Clock Input]

Differential PECL.

These pins are normally connected to the optical receiver module that has on-board clock recovery.

PIN NAMES (contd.)

OUTPUTS

SDOUTP, SDOUTN [Serial Data Output] Differential PECL.

These pins are normally connected to the optical transmitter module.

LCKDET [Lock Detect] TTL.

Active high signal indicating when the internal clock recovery PLL has locked onto the incoming data stream. LCKDET will go high if LOS is low and good data with acceptable run length and transition density is detected on the incoming data stream. LCKDET is an asynchronous output.

PDO[7:0] [Parallel Data Output] TTL.

A 77.76 Mbyte/s word aligned to the RCVBTCK receive byte clock. PDO7 is the most significant bit (corresponding to bit 1 of each PCM word, the first bit transmitted). PDO[7:0] is updated on the falling edge of RCVBTCK.

RFCKOUT [Reference Clock Output] TTL.

A 51.84MHz clock provided as a reference clock.

RCVBTCK [Receive Byte Clock] TTL.

A 77.76MHz clock that is aligned to the PDO7-0 parallel data output. It is a nominally 50% duty cycle clock.

XMBTCK [Transmit Byte Clock] TTL.

A 77.76MHz reference clock generated from the RFCKIN pin. It is to be used to coordinate byte transfers for serial transmission. PDI7-0 is sampled on the rising edge of XMBTCK.

FRMDET [Frame Detect] TTL.

Indicates SONET frame boundaries in the incoming data stream (SDINP, SDINN). If the framing pattern detection is enabled, with OOF input, FRMDET pulses high for one RCVBTCK cycle when a 48-bit sequence matching the framing pattern is detected on the SDINP, SDINN inputs. FRMDET is updated on the falling edge of RCVBTCK.

CKE622P, CKE622N [622.08 MHz Transmit Clock Output]

Differential PECL.

These pins provide the 622.08MHz transmit clock depending on the state of the CK622SEL pin. When CK622SEL is low the CKE622P will remain high (PECL) and CKE622N will remain low (PECL). These pins can be connected to optical transmit modules that require both data and clock inputs.

OTHER

Vcc	ECL +5V	GND	ECL Ground
AVcc	Analog +5V	AGND	Analog Ground
TVcc	TTL +5V	TGND	TTL Ground
N/C	No Connect ⁽¹⁾		

NOTE

1. Recommended N/C pins are tied to GND (ECL Ground).

ABSOLUTE MAXIMUM RATINGS⁽¹⁾

Symbol	Parameter	Rating	Unit
Vcc, TVcc, AVcc	Power Supply (GND, TGND, AGND = 0V)	0 to +7	V
Vi	Input Voltage (GND, TGND, AGND = 0V)	0 to Vcc	V
IOUT	Output Current	Continuous	50
		Surge	100
Tj	Junction Temperature Range	0 to +125	°C
Tstore	Storage Temperature Range	-65 to +150	°C

NOTE:

1. Permanent device damage may occur if ABSOLUTE MAXIMUM RATINGS are exceeded. This is a stress rating only and functional operation is not implied at conditions other than those detailed in the operational sections of this data sheet. Exposure to ABSOLUTE MAXIMUM RATING conditions for extended periods may affect device reliability.

DC ELECTRICAL CHARACTERISTICS^{(1), (2), (3)}

Vcc = +5V ±5%; VEE = GND = 0V, Tj = 0°C to +125°C

Symbol	Parameter	Min.	Typ.	Max.	Unit	Condition
IEE	Internal Operating Current	—	548	—	mA	
IOUT	Termination Output Current	—	11	—	mA	50Ω to Vcc -2, 50% duty cycle

NOTES:

- To calculate total power supply current into the Vcc pins: $I_{CC} = (n * I_{OUT})$; where n = number of ECL output pins used (ie, terminated).
- To calculate total device power dissipation; $P_D = [I_{EE} * (V_{CC} - V_{EE})] + [n * I_{OUT} * 1.33]^{(3)}$.
- Average ECL output voltage is calculated as $V_{OAVG} = (V_{OH(MAX)} + V_{OH(MIN)} + V_{OL(MAX)} + V_{OL(MIN)}) / 4 = 1.33V$.

PECL DC ELECTRICAL CHARACTERISTICS

V_{CC} = TV_{CC} = AV_{CC} = 4.75V to 5.25V; GND, TGND, AGND = 0V, T_J = 0°C to +125°C

Symbol	Parameter	T _J = 0°C		T _J = +25°C		T _J = +65°C		T _J = +125°C		Unit
		Min.	Max.	Min.	Max.	Min.	Max.	Min.	Max.	
V _{OH}	Output HIGH Voltage	V _{CC} -1.112	V _{CC} -0.897	V _{CC} -1.077	V _{CC} -0.862	V _{CC} -1.025	V _{CC} -0.810	V _{CC} -0.947	V _{CC} -0.732	V
V _{OL}	Output LOW Voltage	V _{CC} -1.920	V _{CC} -1.656	V _{CC} -1.920	V _{CC} -1.644	V _{CC} -1.920	V _{CC} -1.620	V _{CC} -1.920	V _{CC} -1.584	V
V _{IH}	Input HIGH Voltage ⁽¹⁾	V _{CC} -1.209	V _{CC} -0.888	V _{CC} -1.172	V _{CC} -0.858	V _{CC} -1.125	V _{CC} -0.810	V _{CC} -1.045	V _{CC} -0.738	V
V _{IL}	Input LOW Voltage ⁽¹⁾	V _{CC} -1.920	V _{CC} -1.604	V _{CC} -1.920	V _{CC} -1.567	V _{CC} -1.920	V _{CC} -1.520	V _{CC} -1.920	V _{CC} -1.140	V
I _{IL}	Input LOW Current	0.5	—	0.5	—	0.5	—	0.3	—	μA

NOTE:

1. Forcing one input at a time. Apply V_{IH} (max) or V_{IL} (min) to all other inputs.

TTL DC ELECTRICAL CHARACTERISTICS

V_{CC} = TV_{CC} = AV_{CC} = 4.75V to 5.25V; GND, TGND, AGND = 0V, T_J = 0°C to +125°C

Symbol	Parameter	Min.	Max.	Unit	Condition
V _{OH}	Output HIGH Voltage	2.4	—	V	I _{OH} = -2mA
V _{OL}	Output LOW Voltage	—	0.5	V	I _{OL} = 4mA
I _{OS}	Output Short Circuit Current	-150	-60	mA	V _{OUT} = 0V
V _{IH}	Input HIGH Voltage	2.0	—	V	—
V _{IL}	Input LOW Voltage	—	0.8	V	—

AC ELECTRICAL CHARACTERISTICS

V_{CC} = TV_{CC} = AV_{CC} = 4.75V to 5.25V; GND, TGND, AGND = 0V, T_J = 0°C to +125°C

Parameter	Min.	Typ.	Max.	Units	Condition
VCO Center Frequency	622.08 ±12%			MHz	Nominal
Reference Clock (RFCKIN) Frequency Tolerance	—	±20	—	ppm	77.76MHz
	—	±20	—	ppm	51.84MHz
	—	±10	—	ppm	19.44MHz
Reference Clock (RFCKIN) Input Duty Cycle	45	—	55	% of UI	
Reference Clock (RFCKOUT) Output Duty Cycle	40	—	60	% of UI	15pF load
Acquisition Lock Time	—	—	15	μsec	
TTL Output Rise/Fall Time	—	—	4	ns	10% to 90% of amplitude, 15pF load
PECL Output Rise/Fall Time	—	—	500	ps	10% to 90%, 50Ω load, 5pF cap
t _{PDI} : PDI[7:0] set-up with respect to XMBTCK	1.8	—	—	ns	15pF load
t _{DHI} : PDI[7:0] hold time with respect to XMBTCK	1	—	—	ns	15pF load
t _{OOFF} : OOF pulse width	12.86	—	—	ns	
t _{RS} D : PDO[7:0] & FRMDET valid before RCVBTCK	4	—	—	ns	15pF load
t _{RH} D : PDO[7:0] & FRMDET valid after RCVBTCK	4	—	—	ns	15pF load
XMBTCK & RCVBTCK Duty Cycle	40	—	60	% of UI	
CKE622 Output Duty Cycle	45	—	55	% of UI	
t _{TSD} : SDOUTP valid before CKE622	0.30	—	—	ns	
t _{THD} : SDOUTP valid after CKE622	0.30	—	—	ns	
t _{RST} : RSTN pulse width	1	—	—	msec	

TRANSMIT TIMING WAVEFORMS

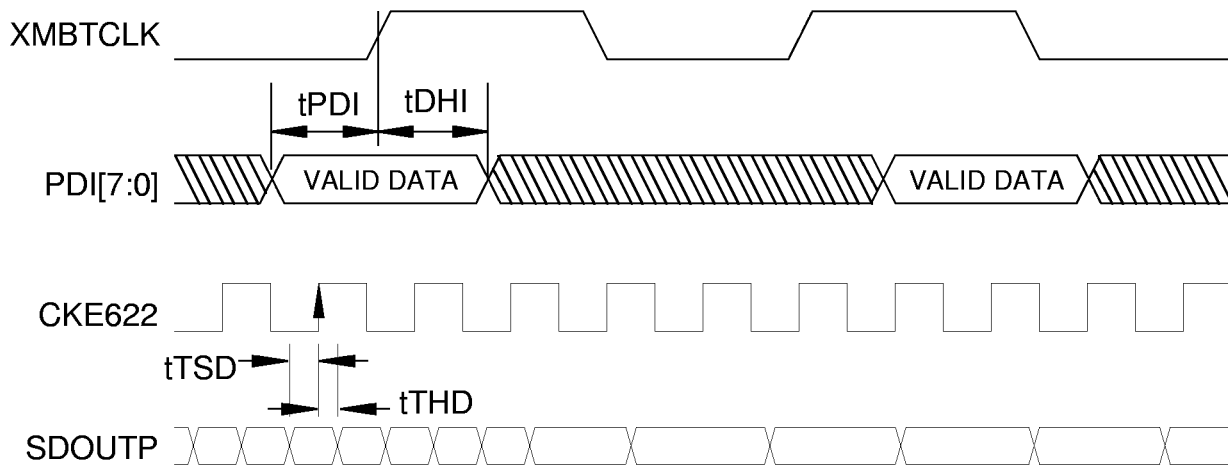

RECEIVE TIMING WAVEFORMS⁽¹⁾

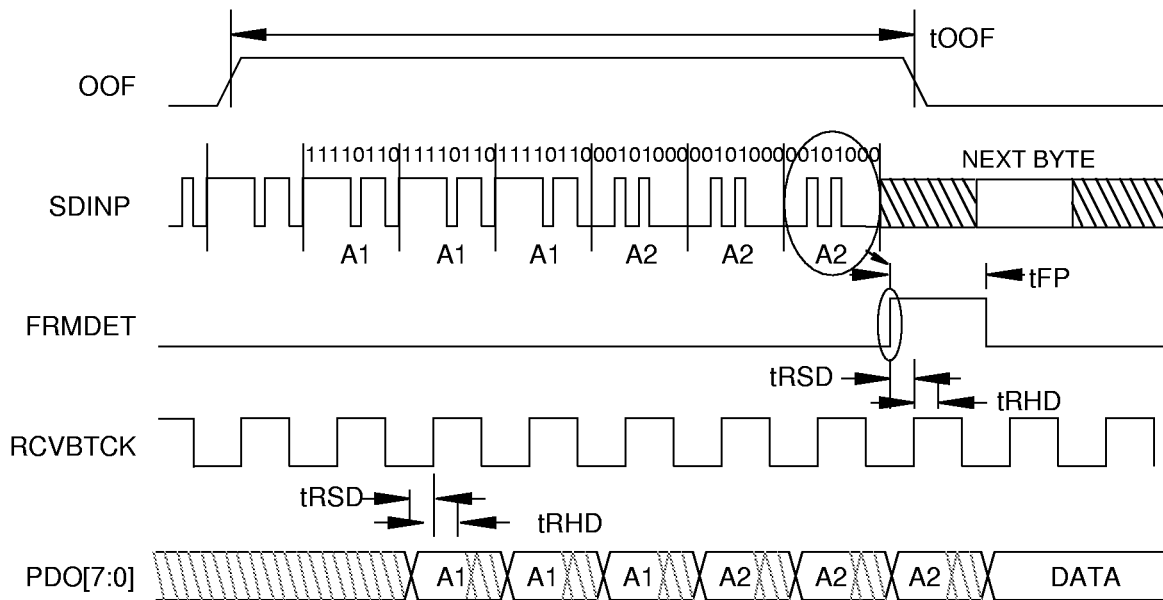

NOTES:

1. The example shown above is for a partial OC-12 framing sequence.

APPLICATION EXAMPLE

SY69712A interface with S/UNI-622

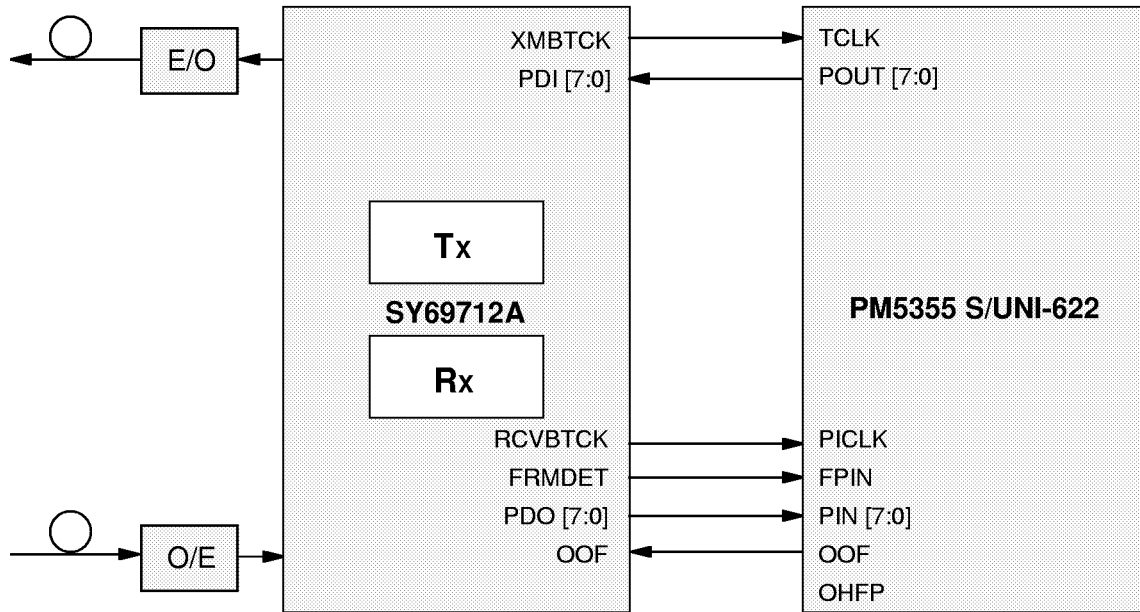

PRODUCT ORDERING CODE

Ordering Code	Package Type	Operating Range
SY69712ABC	B100-1	Commercial
SY69712AQC	Q100-1	Commercial