

Standard Products

ACT4468D Dual Transceivers

for MIL-STD-1553, MIL-STD-1760 & SAE-AS15531

www.aeroflex.com/Avionics

February 18, 2005



FEATURES

- Small size, light weight and low power dissipation dual transceiver
- Single +5V DC power supply operation
- Outstanding MIL-STD-1553 / MIL-STD-1760 / SAE-AS15531 performance
- Monolithic construction
- Current source output
- Designed for commercial, industrial and aerospace applications
- MIL-PRF-38534 compliant devices available
- Aeroflex-Plainview is a Class H & K MIL-PRF-38534 manufacturer

GENERAL DESCRIPTION

The Aeroflex-Plainview ACT4468D is the next generation monolithic transceiver design which provides full compliance with MIL-STD-1553/1760 and meets SAE-AS15531 requirements in the smallest packages with the lowest standby power consumption and one power supply operation.

The dual channel Model ACT4468D perform the front-end analog function of inputting and outputting data through a transformer to a MIL-STD-1553/1760 data bus.

Design of these transceivers reflects particular attention to active filter performance. This results in low bit and word error rate with superior waveform purity and minimal zero crossover distortion. Efficient transmitter electrical and thermal design provides low internal power dissipation and heat rise at high as well as low duty cycles. Each channel of the dual transceiver is completely separate from the other and fully independent. This includes power leads as well as signal lines. Hence, each channel may be connected to a different data bus with no interaction.

TRANSMITTER

The transmitter section accepts bi-phase TTL data at the input and when coupled to the data bus with a 1:2.5 ratio transformer the data bus signal is typically 7.5 Volts P-P at Point A-A' (See Figure 5). When both DATA and $\overline{\text{DATA}}$ inputs are held low, the transmitter output becomes a high impedance and is "removed" from the line. In addition, an overriding "INHIBIT" input provides for the removal of the transmitter output from the line. A logic "1" applied to the "INHIBIT" takes priority over the condition of the data inputs and disables the transmitter (See Figure 1 Transmitter Logic Waveform).

The transceiver utilizes an active filter to suppress harmonics above 1MHz. The Transmitter may be safely operated at 100% duty cycle for an indefinite period into a short circuited 1553 bus.

RECEIVER

The Receiver section accepts bi-phase differential data at the input and produces two TTL signals at the output. The outputs are DATA and $\overline{\text{DATA}}$, and represent positive and negative excursions of the input beyond a pre-determined threshold (See Receiver Logic Waveform. Figure 2).

The pre-set internal thresholds will detect data bus signals exceeding 1.150 Volts P-P and reject signals less than 0.6 volts P-P when used with a 1:2.5 turns ratio transformer (See Figure 5 for transformer data and typical connection).

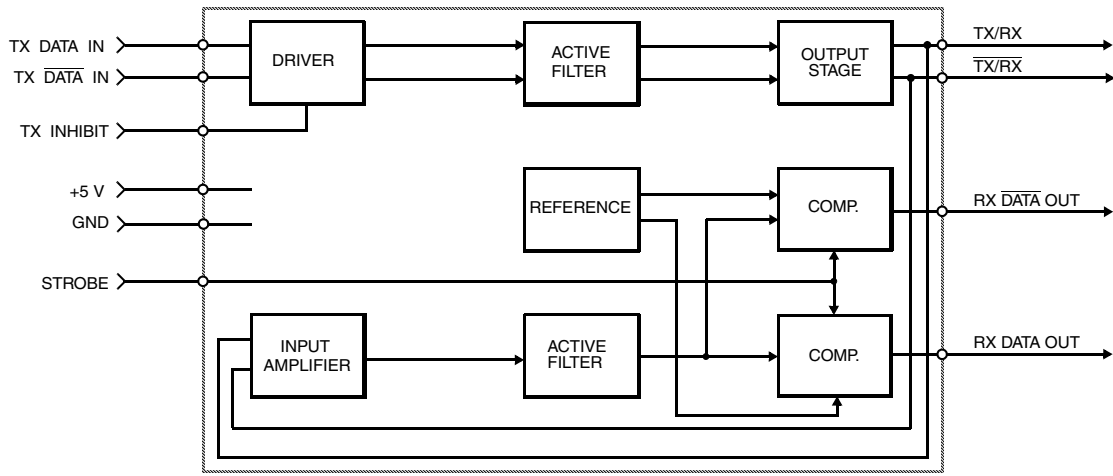

BLOCK DIAGRAM (WITHOUT TRANSFORMER), 1/2 OF UNIT SHOWN

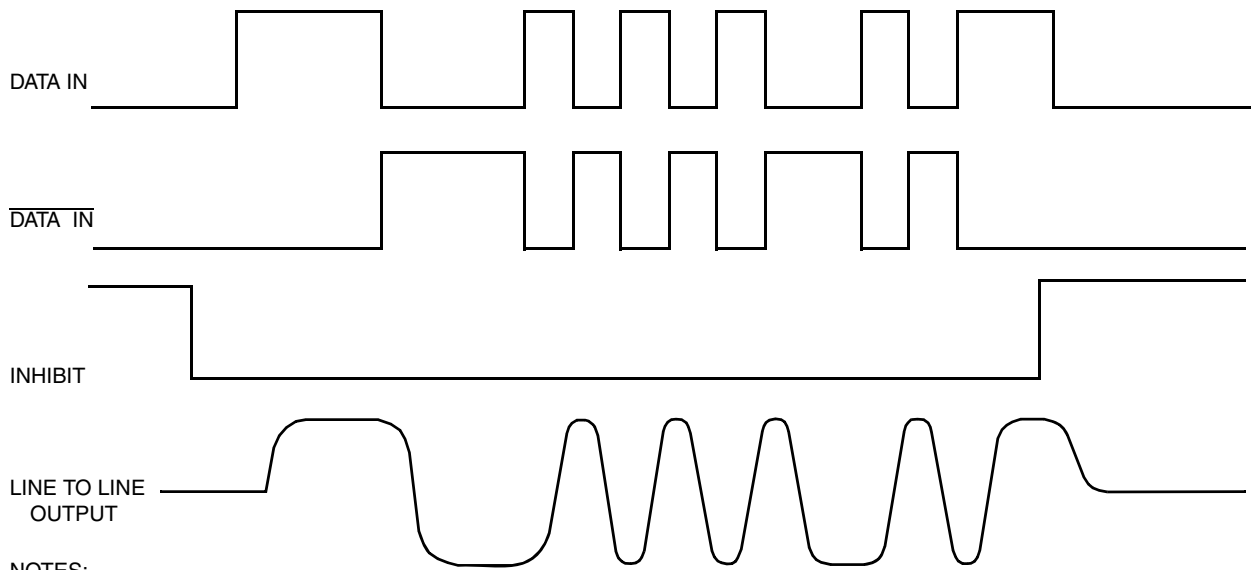

NOTES:

DATA and $\overline{\text{DATA}}$ inputs must be complementary waveforms or 50% duty cycle average, with no delays between them, and must be in the same state during off times (both high or low).

FIGURE 1 – TRANSMITTER LOGIC WAVEFORMS IDEALIZED

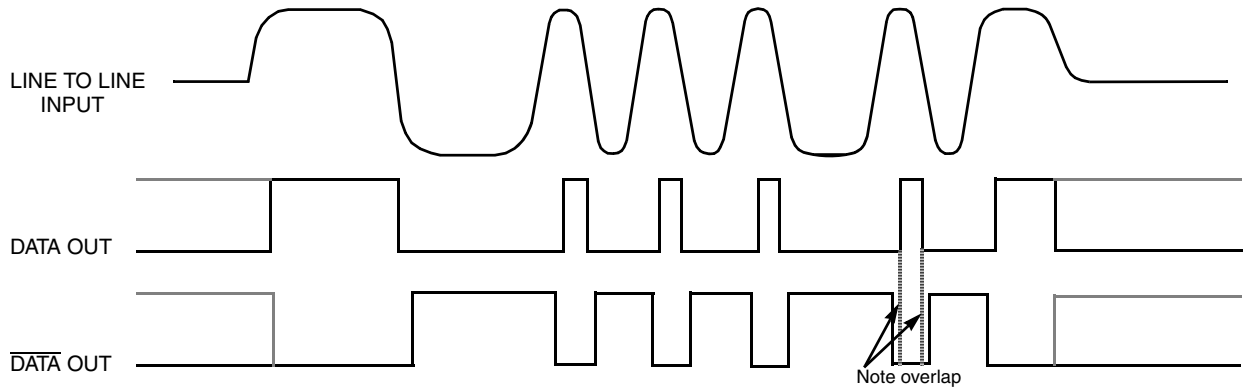

NOTE: Waveforms shown are for normally low devices. For normally high receiver output level devices, the receiver outputs are swapped as shown by the dashed lines.

FIGURE 2 – RECEIVER LOGIC WAVEFORMS IDEALIZED

ABSOLUTE MAXIMUM RATINGS

Operating Case Temperature	-55°C to +125°C
Storage Case Temperature	-65°C to +150°C
Positive Power Supply Voltage	-0.3 VDC to +7.0 VDC
Receiver Differential Input	±10V
Receiver Input Voltage (Common Mode)	±5V
Driver Peak Output Current	650 mA
Total Package Power Dissipation over the Full Operating Case Temperature Range	2 Watts (Note: Normal operation conditions require one transmitter on and the other off at any given time)
Maximum junction to Case Temperature	10°C
Thermal resistance – Junction to Case	5°C/W

ELECTRICAL CHARACTERISTICS – DRIVER SECTION

INPUT CHARACTERISTICS, TX DATA IN OR TX DATA IN

Parameter	Condition	Symbol	Min	Typ	Max	Unit
"0" Input Current	V _{IN} = 0.4V	I _{ILD}	-	-0.2	-0.4	mA
"1" Input Current	V _{IN} = 2.7V	I _{IHD}	-	1	40	μA
"0" Input Voltage		V _{ILD}	-	-	0.7	V
"1" Input Voltage		V _{IHD}	2.0	-	-	V

INHIBIT CHARACTERISTICS

"0" Input Current	V _{IN} = 0.4V	I _{ILI}	-	-0.1	-0.2	mA
"1" Input Current	V _{IN} = 2.7V	I _{IHI}	-	1.0	40	μA
"0" Input Voltage		V _{ILI}	-	-	0.7	V
"1" Input Voltage		V _{IHI}	2	-	-	V
Delay from TX inhibit, (0→1) to inhibited output		t _{DXOFF}	-	200	300	nS
Delay from TX inhibit, (1→0) to active output		t _{DXON}	-	80	150	nS
Differential Output Noise, inhibit mode		V _{NOI}	-	2	10	mVp-p
Differential Output Impedance (inhibited)	Note 1	Z _{OI}	2K	-	-	Ω

Note 1. Power ON/OFF, measured from 75KHz to 1MHz at Point A-A. See Figure 5.

OUTPUT CHARACTERISTICS

Differential output level	R _L = 35Ω	V _O	6.5	7.5	8.0	Vp-p
Rise and fall times (10% to 90% of Vp-p output)		t _r	100	170	300	nS
Output Offset at point A-A' on Figure 5, 2.5μS after midpoint crossing of the parity bit of the last word of a 660μS message	R _L = 35Ω	V _{OS}	-	-	±90	mVpeak
Delay from 50% point of TX DATA or TX DATA input to zero crossing of differential signal		t _{DTX}	-	100	200	nS

ELECTRICAL CHARACTERISTICS – RECEIVER SECTION

Parameter	Condition	Symbol	Min	Typ	Max	Unit
Differential Voltage Range, Figure 4 Point P-P'		V_{IDR}	-	-	20	Vpk
Common Mode Rejection Ratio (Note 3)		CMRR	45	-	-	dB

STROBE CHARACTERISTICS (LOGIC "0" INHIBITS OUTPUT)

"0" Input Current	$V_S = 0.4V$	I_{IL}	-	-0.2	-0.4	mA
"1" Input Current	$V_S = 2.7V$	I_{IH}	-	1	+40	μA
"0" Input Voltage		V_{IL}	-	-	0.7	V
"1" Input Voltage		V_{IH}	2.0	-	-	V
Strobe Delay (Turn-on)		$t_{SD(ON)}$	-	40	100	nS
Strobe Delay (Turn-off)		$t_{SD(OFF)}$	-	60	100	nS

THRESHOLD CHARACTERISTICS (SINEWAVE INPUT)

Input Threshold Voltage (Referred to the bus)	100KHz-1MHz	V_{TH}	0.60	0.8	1.15	V_{p-p}
---	-------------	----------	------	-----	------	-----------

OUTPUT CHARACTERISTICS, RX DATA AND $\overline{RX DATA}$

"1" State	$I_{OH} = -0.4 \text{ mA}$	V_{OH}	2.5	3.7	-	V
"0" State	$I_{OL} = 4 \text{ mA}$	V_{OL}	-	0.3	0.5	V
Delay, (average) from differential input zero crossings to RX DATA and $\overline{RX DATA}$ output 50% points		t_{DRX}	-	250	400	nS

POWER DATA

MAXIMUM CURRENTS, PER CHANNEL (+5V)

Duty Cycle	Typ	Max
Transmitter Standby	20 mA	30 mA
25% duty cycle	155 mA	185 mA
50% duty cycle	290 mA	335 mA
100% duty cycle	560 mA	650 mA

POWER SUPPLY VOLTAGE

+V	4.75 to 5.5 Volts
----	-------------------

Note 2. $V_{CC} = 5 \text{ Volts} \pm 0.1 \text{ V}$, for all measurements unless otherwise specified.

Note 3. Specifications apply over the case temperature range of -55°C to $+125^{\circ}\text{C}$ unless otherwise specified.

Note 4. All typical values are measured at $+25^{\circ}\text{C}$.

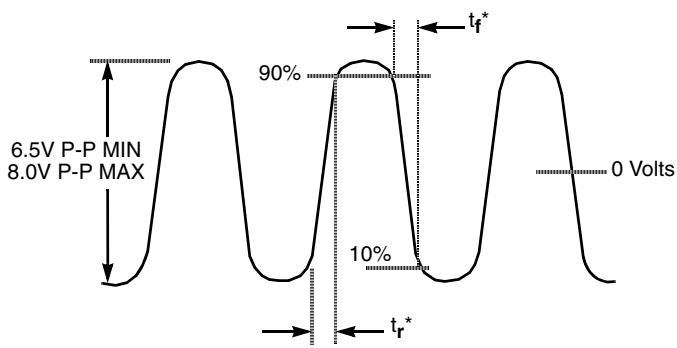

* Rise and fall times measured at point A-A' in Figure 5

FIGURE 3 – TRANSMITTER (TX) OUTPUT WAVEFORM

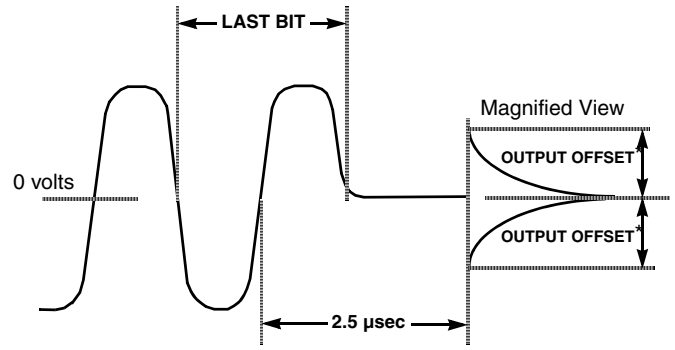

*Offset measured at point A-A' in Figure 5

FIGURE 4 – TRANSMITTER (TX) OUTPUT OFFSET

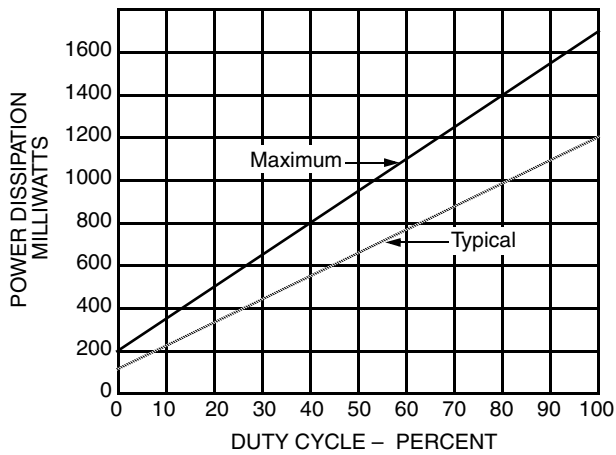

Note: $V_{cc} = +5$ Volts, V_{BUS} (point A-A') at 7.5 Volts P-P

FIGURE 5 – POWER DISSIPATION VS. DUTY CYCLE

(Total hybrid with one channel transmitting and the other not powered)

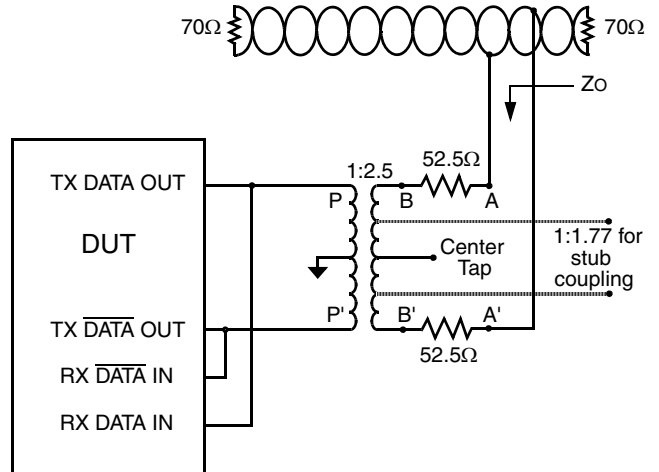
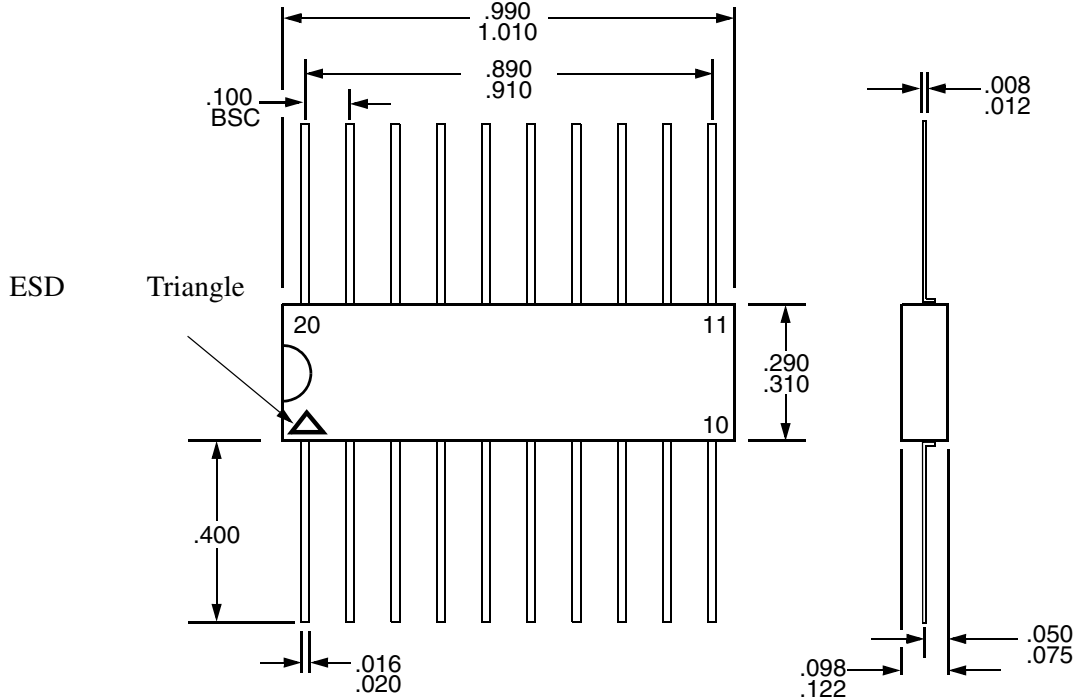

FIGURE 6 – TYPICAL TRANSFORMER CONNECTION

PACKAGE OUTLINE DRAWINGS

"FLAT Package"



"DIP Package"

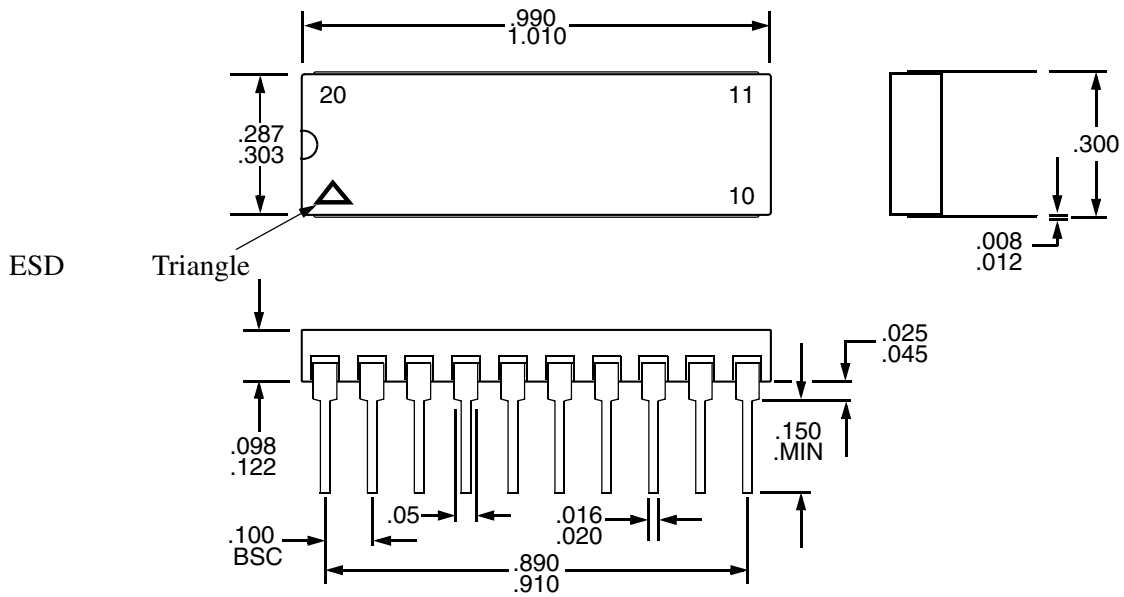

Notes

1. Dimensions shown are in inches

CONFIGURATIONS AND ORDERING INFORMATION

Model No.	Receiver Data level	Case	Configuration
ACT4468D	Normally Low	DIP Package	Dual
ACT4468DF	Normally Low	Flat Package	
ACT4468DI	Normally High	DIP Package	
ACT4468DFI	Normally High	Flat Package	

PIN # vs FUNCTION TABLE

Pin	Function	Pin	Function
1	+5VDC A	11	RX $\overline{\text{DATA}}$ OUT B
2	TX/RX A	12	RX DATA OUT B
3	$\overline{\text{TX/RX}}$ A	13	TX INHIBIT B
4	STROBE A	14	TX DATA IN B
5	GROUND A	15	TX $\overline{\text{DATA}}$ IN B
6	+5VDC B	16	RX $\overline{\text{DATA}}$ OUT A
7	TX/RX B	17	RX DATA OUT A
8	$\overline{\text{TX/RX}}$ B	18	TX INHIBIT A
9	STROBE B	19	TX DATA IN A
10	GROUND B	20	TX $\overline{\text{DATA}}$ IN A

PLAINVIEW, NEW YORK
Toll Free: 800-THE-1553
Fax: 516-694-6715

INTERNATIONAL
Tel: 805-778-9229
Fax: 805-778-1980

NORTHEAST
Tel: 603-888-3975
Fax: 603-888-4585

SE AND MID-ATLANTIC
Tel: 321-951-4164
Fax: 321-951-4254

WEST COAST
Tel: 949-362-2260
Fax: 949-362-2266

CENTRAL
Tel: 719-594-8017
Fax: 719-594-8468

www.aeroflex.com info-ams@aeroflex.com

Aeroflex Microelectronic Solutions reserves the right to change at any time without notice the specifications, design, function, or form of its products described herein. All parameters must be validated for each customer's application by engineering. No liability is assumed as a result of use of this product. No patent licenses are implied.



Our passion for performance is defined by three attributes represented by these three icons: solution-minded, performance-driven and customer-focused