



Cortina Systems® LXT9860/LXT9880 Advanced 10/100 Repeater with Integrated Management

Datasheet

The Cortina Systems® LXT9860/LXT9880 Advanced 10/100 Repeater with Integrated Management (LXT98x0 Repeater) is the next-generation repeater family, integrated with six/eight 10/100 transceivers. The LXT98x0 Repeater is compatible with previous generations of Intel® Repeaters from the LXT980 and LXT918 families. In the LXT9880 Repeater, eight ports directly support 100BASE-TX/10BASE-T copper media. Two additional Media Independent Interface (MII) ports (10/100 Mbps selectable) connect to Media Access Controllers (MACs) for bridge/switch applications. The LXT9860 Repeater offers the same features and functionality in a six-port device.

The LXT98x0 Repeater provides auto-negotiation with parallel detection for the PHY ports. The LXT98x0 Repeater provides two internal repeater state machines—one operating at 10 Mbps and one at 100 Mbps. Once configured, the LXT98x0 Repeater automatically connects each port to the appropriate repeater. The LXT98x0 Repeater also provides two Inter-Repeater Backplanes (IRBs) for expansion — one operating at 10 Mbps and one at 100 Mbps. Up to 240 twisted-pair and MII ports can logically be combined into one repeater. The LXT98x0 Repeater supports SNMP and RMON management via on-chip 32- and 64-bit counters. The counters and control functions are accessible via a high-speed Serial Management Interface (SMI).

Product Features

- Six or eight 10/100 ports with integrated twisted-pair PHYs including integrated filters.
- Two 10/100 MIIs for bridging.
- Independent segments for 10 Mbps and 100 Mbps operation.
- Cascadable Inter-Repeater Backplanes (IRBs), with option for 5 V stacking compatibility.
- Hardware assist for RMON and the Repeater MIB.
- High-speed Serial Management Interface (SMI).
- Two address-tracking registers per port.
- Source Address matching function.
- Integrated LED drivers with user-selectable modes.
- Available in 208-pin QFP package.
- Operating temperature range: 0-70 °C, ambient.
- Available in extended temperature range: -40 to +85 °C, ambient.

Note: The LXT9880 Repeater and the LXT9860 Repeater are not recommended for new designs. Contact your Cortina Systems, Inc. representative for product availability.

This document contains information proprietary to Cortina Systems, Inc. (Cortina). Any use or disclosure, in whole or in part, of this information to any unauthorized party, for any purposes other than that for which it is provided is expressly prohibited except as authorized by Cortina in writing. Cortina reserves its rights to pursue both civil and criminal penalties for copying or disclosure of this material without authorization.

INFORMATION IN THIS DOCUMENT IS PROVIDED IN CONNECTION WITH CORTINA SYSTEMS® PRODUCTS.

NO LICENSE, EXPRESS OR IMPLIED, BY ESTOPPEL OR OTHERWISE, TO ANY INTELLECTUAL PROPERTY RIGHTS IS GRANTED BY THIS DOCUMENT.

EXCEPT AS PROVIDED IN CORTINA'S TERMS AND CONDITIONS OF SALE OF SUCH PRODUCTS, CORTINA ASSUMES NO LIABILITY WHATSOEVER, AND CORTINA DISCLAIMS ANY EXPRESS OR IMPLIED WARRANTY RELATING TO THE SALE AND/OR USE OF CORTINA PRODUCTS, INCLUDING LIABILITY OR WARRANTIES RELATING TO FITNESS FOR A PARTICULAR PURPOSE, MERCHANTABILITY OR INFRINGEMENT OF ANY PATENT, COPYRIGHT OR OTHER INTELLECTUAL PROPERTY RIGHT.

Cortina products are not intended for use in medical, life saving, life sustaining, critical control or safety systems, or in nuclear facility applications.

Cortina Systems® and the Cortina Systems logo are the trademarks or registered trademarks of Cortina Systems, Inc. and its subsidiaries in the U.S. and other countries. Other names and brands may be claimed as the property of others.

Copyright © 2001–2007 Cortina Systems, Inc. All rights reserved.

Contents

1.0	Pin Assignments and Signal Descriptions	10
2.0	Functional Description.....	29
2.1	Introduction	29
2.2	Port Configuration.....	30
2.2.1	Auto-Negotiation	30
2.2.2	Forced Operation.....	30
2.2.3	Changing Port Speed - Forced	30
2.2.4	Link Establishment and Port Connection.....	30
2.2.5	MII Port Configuration	31
2.3	Interface Descriptions	31
2.3.1	Twisted-Pair Interface	31
2.3.2	Media Independent Interface	31
2.3.3	Serial Management Interface.....	32
2.3.4	Serial PROM Interface	32
2.4	Repeater Operation	32
2.4.1	100 Mbps Repeater Operation	33
2.4.2	10 Mbps Repeater Operation	34
2.5	Management Support	34
2.5.1	Configuration and Status	34
2.5.2	SNMP and RMON Support.....	35
2.5.3	Source Address Management	35
2.6	Requirements	35
2.6.1	Power.....	35
2.6.2	Clock.....	35
2.6.3	Bias Resistor.....	35
2.6.4	Reset	35
2.6.5	PROM	36
2.6.6	Chip ID.....	36
2.6.7	Management Master I/O Link	36
2.6.8	IRB Bus Pull-ups.....	36
2.7	LED Operation	37
2.7.1	LEDs at Start-up	37
2.7.2	LED Event Stretching	37
2.7.3	LED Blink Rates.....	37
2.7.4	Serial LED Interface.....	37
2.7.5	Direct Drive LEDs	40
2.7.6	LED Modes	40
2.8	IRB Operation	45
2.8.1	IRB Signal Types	46
2.8.2	IRB Isolation	46
2.8.3	10 Mbps-Only Operation.....	46
2.8.4	LXT98x/91x/98x0 Compatibility	46
2.9	MII Port Operation	49
2.9.1	Preamble Handling	49
2.10	Serial Management I/F	50
2.10.1	SMI Signals.....	50
2.10.2	Read and Write Operations	51

2.10.3	Address Assignment Methods	55
2.10.4	Interrupt Functions	57
2.11	Serial PROM Interface	57
2.12	Serial Configuration Interface	58
3.0	Application Information	60
3.1	General Design Guidelines	60
3.2	Typical Applications	60
3.3	Application Circuitry	61
3.3.1	Power and Ground	61
3.3.2	MII Terminations	63
3.3.3	Twisted-Pair Interface	64
3.3.4	Clock	65
3.3.5	SMI and PROM Circuits	66
3.3.6	LED Circuits	67
3.4	Inter-Repeater Backplane Compatibility	69
3.4.1	Local Backplane—3.3 V Only	70
3.4.2	Stack Backplane—3.3 V or 5 V	70
4.0	Test Specifications	73
5.0	Register Definitions.....	87
5.1	Register Map	87
5.2	Counter Registers	95
5.2.1	Port Counter Registers	96
5.2.2	RMON Counter Registers	97
5.3	Ethernet Address Registers	100
5.3.1	Port Address Registers	100
5.3.2	Search Address Registers	100
5.4	Repeater Port Control Registers.....	102
5.4.1	General Port Control Registers.....	102
5.4.2	Port Link Control Register.....	103
5.4.3	Port Learn Enable Register	104
5.5	Repeater Port Status Registers	104
5.6	PHY Port Status Registers	105
5.7	PHY Port Control Registers	109
5.8	Repeater Port Control/Status Registers	110
5.8.1	Device/Revision Register.....	112
5.8.2	LED Control Registers	113
5.8.3	LED Global Control Register	113
5.8.4	Port LED Control Register	113
5.8.5	LED Timer Control Register.....	114
5.8.6	Repeater Reset Register	115
5.8.7	Software Reset Register	115
5.8.8	Interrupt Registers	115
5.9	Serial Controller Registers	117
6.0	Mechanical Specifications.....	119

Figures

1	Block Diagram	9
2	Pin Assignments	10
3	Typical LXT988x Managed Repeater Architectures	29
4	MII Interface	32
5	LED Blink Rates	37
6	Serial LED Shift Loading	38
7	Serial LED Port Signaling	39
8	100 Mbps IRB Connection	47
9	IRB Block Diagram	48
10	LXT9880 Repeater MII Operation	50
11	Typical SMI Bus Architecture	50
12	SMI Collision Handling	52
13	SMI Address Match Indication	52
14	Serial Management Frame Format	53
15	Address Arbitration Mechanisms	56
16	Optional R/W Serial PROM Interface	58
17	Serial Configuration Interface	59
18	Serial Configuration Interface Signaling	59
19	8-Port Managed 10/100 Stackable Repeater	60
20	32-Port Managed 10/100 Repeater	61
21	Power and Ground Connections	63
22	Typical Twisted-Pair Port Interface and Power Supply Filtering	65
23	Typical Serial Management Interface Connections	66
24	Serial Controller Connection Showing PAL	66
25	Serial PROM Interface	67
26	Typical Reset Circuit	67
27	LED Circuits - Direct Drive & Multiplexed Configuration Inputs	68
28	Serial LED Circuit	69
29	100 Mbps Backplane Connection between LXT98x and LXT98x0 Repeater	71
30	Typical 100 Mbps IRB Implementation	72
31	Typical 10 Mbps IRB Implementation	72
32	100 Mbps TP Port-to-Port Delay Timing	77
33	100BASE-TX MII-to-TP Port Timing	78
34	100BASE-TX TP-to-MII Timing	79
35	10BASE-T MII-to-TP Timing	80
36	10BASE-T TP-to-MII Timing	81
37	100 Mbps TP-to-IRB Timing	82
38	10 Mbps TP-to-IRB Timing	82
39	10 Mbps IRB-to-TP Port Timing	83
40	Serial Management Interface Timing	84
41	PROM Interface Timing	85
42	Package Specifications for Commercial Temperature	119
43	LXT98x0 Repeater Package Specifications for Extended Temperature	120

Tables

1	Signal Types.....	11
2	Pins, Numeric Order.....	11
3	MII #1 Signal Descriptions.....	18
4	MII #2 Signal Descriptions.....	19
5	Inter-Repeater Backplane Signal Descriptions.....	20
6	Twisted-Pair Port Signal Descriptions.....	23
7	Serial Management Interface Signal Descriptions.....	24
8	LED Signal Descriptions.....	25
9	Power Supply and Indication Signal Descriptions.....	26
10	PROM Interface Signal Descriptions.....	27
11	Miscellaneous Signal Descriptions.....	28
12	Serial LED Port Bit Stream.....	39
13	ACTGLED Display Modes.....	40
14	LED Terms.....	41
15	LED Mode 1 Indications.....	42
16	LED Mode 2 Indications.....	43
17	LED Mode 3 Indications.....	44
18	LED Mode 4 Indications.....	45
19	Cascading and Stacking Connections.....	48
20	IRB Signal Details.....	49
21	SMI Message Fields.....	53
22	SMI Header Storage.....	53
23	SMI Command Set.....	54
24	Typical Serial Management Packets.....	55
25	LXT98x0 Repeater Magnetics Specifications.....	64
26	Oscillator Manufacturers.....	65
27	Absolute Maximum Ratings.....	73
28	Operating Conditions.....	73
29	Input System Clock ¹ Requirements.....	73
30	I/O Electrical Characteristics.....	74
31	100 Mbps IRB Electrical Characteristics.....	74
32	10 Mbps IRB Electrical Characteristics.....	75
33	100BASE-TX Transceiver Electrical Characteristics.....	76
34	10BASE-T Transceiver Electrical Characteristics.....	76
35	100 Mbps TP Port-to-Port Delay Timing Parameters.....	77
36	100BASE-TX MII-to-TP Port Timing Parameters.....	78
37	100BASE-TX TP-to-MII Timing Parameters.....	79
38	10BASE-T MII-to-TP Timing Parameters.....	80
39	10BASE-T TP-to-MII Timing Parameters.....	81
40	100 Mbps TP-to-IRB Timing Parameters ¹	82
41	10 Mbps TP-to-IRB Timing Parameters ¹	83
42	10 Mbps IRB-to-TP Port Timing Parameters.....	84
43	Serial Management Interface Timing Characteristics.....	84
44	PROM Interface Timing Characteristics.....	85
45	Register Map.....	87
46	Port Counter Registers.....	96
47	RMON Counter Registers - 10 Mbps.....	97
48	RMON Counter Registers - 100 Mbps.....	99

49	Ethernet Address Register Bit Assignments	100
50	Port Address Tracking Registers	100
51	Search Address/Search Address Match Register	101
52	Search Address Register Bit Assignments	101
53	Search Match Address Bit Assignments	101
54	Search Match Address Bit Definitions	101
55	Port Control Register Bit Assignments	102
56	General Port Control Registers	103
57	Port Link Control and Status Register Bit Assignments	103
58	Port Link Control Register	103
59	Port Learn Enable Register	104
60	Port Learn Enable Register	104
61	Port Status Register Bit Assignments	104
62	Port Status Registers	105
63	MII Speed Status Bit Assignments	105
64	MII Status Bit Definitions	105
65	Auto-Negotiation Registers	106
66	Auto-Negotiate Link Partner Advertisement Bit Definitions	106
67	Auto-Negotiate Expansion Bit Definitions	107
68	PHY Port Status Register Summary	107
69	PHY Port Status Register Bit Definitions	108
70	Auto-Negotiation Advertisement Registers	109
71	Auto Negotiate Advertisement Bit Definitions	109
72	PHY Port Control Register	109
73	PHY Port Control Bit Definitions	110
74	Configuration Registers	110
75	Repeater Configuration Register	111
76	Repeater Serial Configuration	112
77	Device/Revision Register Bit Assignment	113
78	Global Fault LED Bit Assignments	113
79	LED Configuration	113
80	Port LED1, 2, 3 Control Encodings	114
81	LED Timer Control Register Bit Assignments	114
82	Repeater Reset	115
83	Software Reset	115
84	Interrupt Status/Mask Register	115
85	Interrupt Status Register Bit Definitions	116
86	Interrupt Mask Bit Definitions	117
87	Configuration Registers	117
88	Assign Addr 1	117
89	Assign Addr 2	118
90	PROM Addr 1	118
91	PROM Addr 2	118

Revision History

Revision 5.0 Revision Date: 14 August 2007
First release of this document from Cortina Systems, Inc.
Revision 004 Revision Date: 29 March 2006
<ul style="list-style-type: none">• Added Section 7.1, "Top Label Markings" on page 119.• Added Section 8.0, "Product Ordering Information" on page 121.
Revision 003 Revision Date: August 2001
Changed Absolute Maximum Ratings Supply Voltage value to 4.0 V.
Revision 002 Revision Date: January 2001
<ul style="list-style-type: none">• Added extended temperature range to title page.• Modified LXT98x0 Repeater Pins, Numeric Order table (Pins 10, 11, 17, 19, 20, 185).• Modified clock requirements language.• Replaced TBD with 3.15 V under Reset.• Under Twisted Pair Interface, 4th bullet: Replaced text containing TBDs with: A ferrite bead with a total maximum current rating of 1.5Amp is recommended.• Modified Oscillator Manufacturers table.• Modified Absolute Maximum Ratings table.• Modified Operating Conditions table.• Mechanical Specifications: Add part number LXT98x0 RepeaterAHC to LXT98x0 Repeater Package Specifications Commercial Temperature figure; Add page for LXT98x0 Repeater Package Specifications Extended Temperature figure.
Revision 001 Revision Date: January 2001
Initial release.

Figure 1 Block Diagram

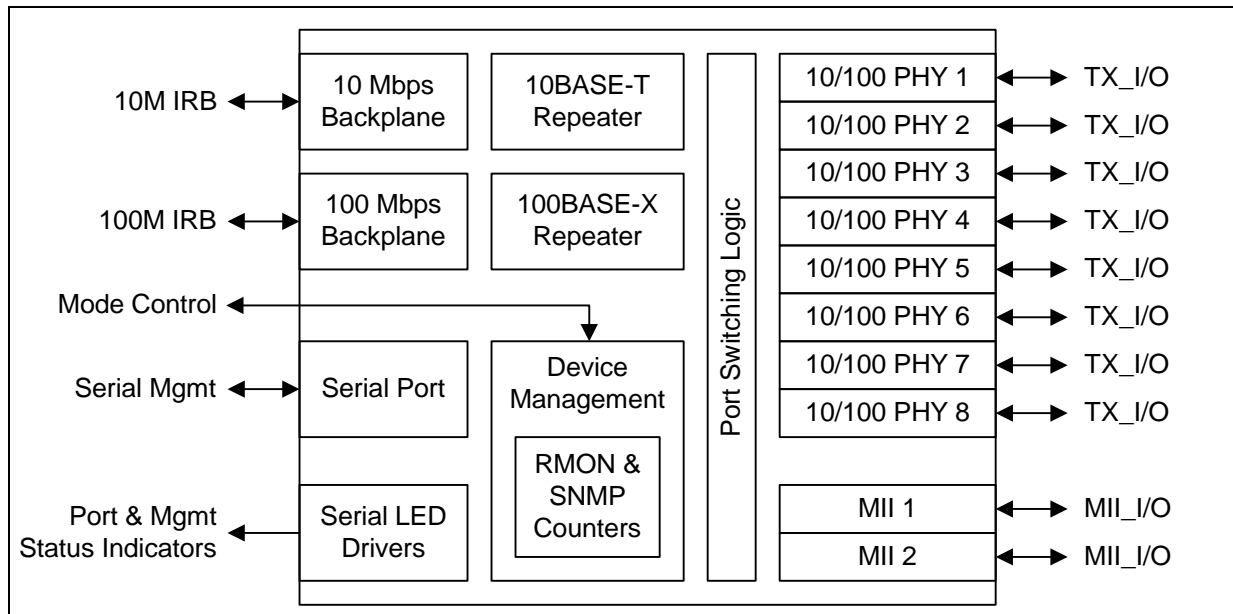

1.0 Pin Assignments and Signal Descriptions

Figure 2 Pin Assignments

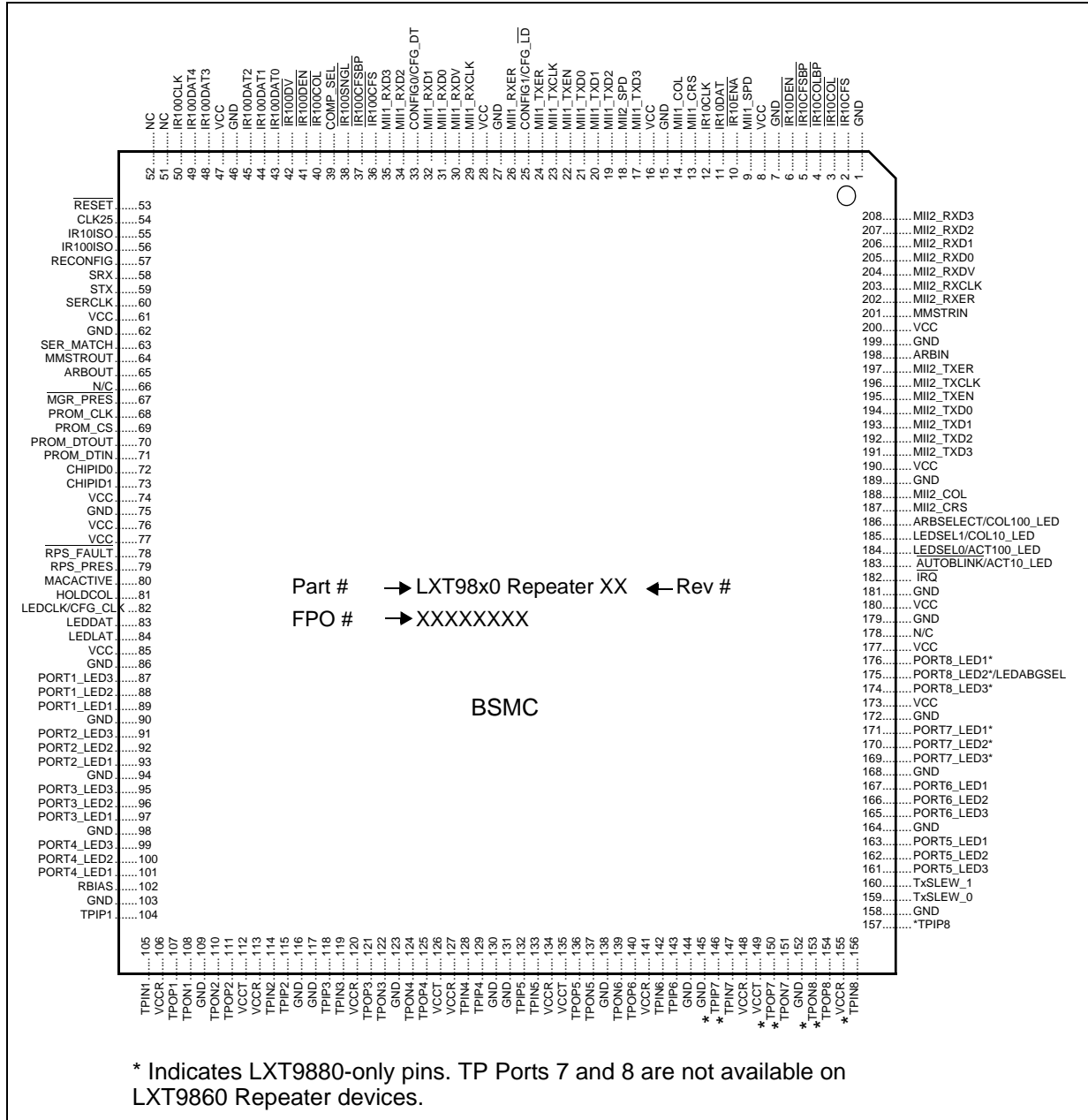

Table 1 Signal Types

Type	Name	Definition
I	Input	Standard input-only signal.
O	Output	Standard output-only signal.
I/O	Bidirectional	Input and output signal.
A	Analog	Current source signal.
OD	Open Drain	Output that will only drive the signal Low.
OS	Open Source	Output that will only drive the signal High.
PD	Pull Down	Internal, weak pull down signal.
PU	Pull Up	Internal, weak pull up signal.
NC	No Clamp	Pad does not clamp input in the absence of power.

Table 2 Pins, Numeric Order (Sheet 1 of 7)

Pin	Symbol	Type ^{1,2}	Reference for Full Description
1.	GND	—	Table 9 on page 26
2.	IR10CFS	A, I/O, OD	Table 5 on page 20
3.	IR10COL	I/O, OD, PU	Table 5 on page 20
4.	IR10COLBP	I/O, OD	Table 5 on page 20
5.	IR10CFSBP	A I/O, OD	Table 5 on page 20
6.	IR10DEN	O, OD	Table 5 on page 20
7.	GND	—	Table 9 on page 26
8.	VCC	—	Table 9 on page 26
9.	MII1_SPD	I, PU	Table 3 on page 18
10.	IR10ENA	O	Table 3 on page 18
11.	IR10DAT	O	Table 3 on page 18
12.	IR10CLK	I/O	Table 5 on page 20
13.	MII1_CRIS	O	Table 3 on page 18
14.	MII1_COL	O	Table 3 on page 18
15.	GND	—	Table 9 on page 26
16.	VCC	—	Table 9 on page 26
17.	MII1_TXD3	I	Table 3 on page 18
18.	MII2_SPD	I	Table 3 on page 18
19.	MII1_TXD2	I	Table 3 on page 18
20.	MII1_TXD1	I	Table 3 on page 18

1. Refer to [Table 1](#) for Signal Type definitions.
 2. Pins are 5 V tolerant, unless indicated.
 3. Input must be static; Refer to [Section 3.3.6.2, LED Pins Multiplexed with Configuration Inputs](#), on page 67 for information on pin use.

Table 2 Pins, Numeric Order (Sheet 2 of 7)

Pin	Symbol	Type ^{1,2}	Reference for Full Description
21.	MII1_TXD0	I	Table 3 on page 18
22.	MII1_TXEN	I	Table 3 on page 18
23.	MII1_TXCLK	I	Table 3 on page 18
24.	MII1_TXER	I	Table 3 on page 18
25.	CONFIG1/CF	I/O	Table 11 on page 28
26.	MII1RXER	I	Table 3 on page 18
27.	GND	—	Table 9 on page 26
28.	VCC	—	Table 9 on page 26
29.	MII1_RXCLK	O	Table 3 on page 18
30.	MII1_RXDV	O	Table 3 on page 18
31.	MII1_RXD0	O	Table 3 on page 18
32.	MII1_RXD1	O	Table 3 on page 18
33.	CONFIG/CFG_DT	I	Table 12 on page 39
34.	MII1_RXD2	O	Table 3 on page 18
35.	MII1_RXD3	O	Table 3 on page 18
36.	$\overline{\text{IR100CFS}}$	A I/O	Table 5 on page 20
37.	$\overline{\text{IR100CFSBP}}$	A I/O	Table 5 on page 20
38.	$\overline{\text{IR100SNGL}}$	I/O	Table 5 on page 20
39.	COMP_SEL	AI	Table 5 on page 20
40.	$\overline{\text{IR100COL}}$	O	Table 5 on page 20
41.	$\overline{\text{IR100DEN}}$	O	Table 5 on page 20
42.	$\overline{\text{IR100DV}}$	I/O	Table 5 on page 20
43.	IR100DAT0	I/O	Table 5 on page 20
44.	IR100DAT1	I/O	Table 5 on page 20
45.	IR100DAT2	I/O	Table 5 on page 20
46.	GND	—	Table 9 on page 26
47.	VCC	—	Table 9 on page 26
48.	IR100DAT3	I/O	Table 5 on page 20
49.	IR100DAT4	I/O	Table 5 on page 20
50.	IR100CLK	I/O	Table 5 on page 20
51.	NC	—	Table 11 on page 28
52.	NC	—	Table 11 on page 28
53.	$\overline{\text{RESET}}$	I	Table 11 on page 28
54.	CLK25	I	Table 11 on page 28

1. Refer to [Table 1](#) for Signal Type definitions.
 2. Pins are 5 V tolerant, unless indicated.
 3. Input must be static; Refer to [Section 3.3.6.2, LED Pins Multiplexed with Configuration Inputs](#), on page 67 for information on pin use.

Table 2 Pins, Numeric Order (Sheet 3 of 7)

Pin	Symbol	Type ^{1,2}	Reference for Full Description
55.	IR10ISO	O	Table 5 on page 20
56.	IR100ISO	O	Table 5 on page 20
57.	RECONFIG	I, PD	Table 7 on page 24
58.	SRX	I, PD	Table 7 on page 24
59.	STX	O, OD	Table 7 on page 24
60.	SERCLK	I/O, Tri-State, PD	Table 7 on page 24
61.	VCC	—	Table 9 on page 26
62.	GND		Table 9 on page 26
63.	SER_MATCH	O	Table 7 on page 24
64.	MMSTROUT	O	Table 5 on page 20
65.	ARABOUT	O	Table 7 on page 24
66.	NC	—	Table 11 on page 28
67.	$\overline{\text{MGR_PRES}}$	I PU	Table 7 on page 24
68.	PROM_CLK	I/O Tri-State PD	Table 10 on page 27
69.	PROM_CS	O, Tri-State	Table 10 on page 27
70.	PROM_DTOUT	O, Tri-State	Table 10 on page 27
71.	PROM_DTIN	I, PD	Table 10 on page 27
72.	CHIPID0	I PD	Table 11 on page 28
73.	CHIPID1	I PD	Table 11 on page 28
74.	VCC	—	Table 9 on page 26
75.	GND	—	Table 9 on page 26
76.	VCC	—	Table 9 on page 26
77.	VCC	—	Table 9 on page 26
78.	$\overline{\text{RPS_FAULT}}$	I, PU	Table 9 on page 26
79.	RPS_PRES	I, PU	Table 9 on page 26
80.	MACACTIVE	I, PD	Table 5 on page 20
81.	HOLDCOL	I/O, PD	Table 5 on page 20
82.	LEDCLK CFG_CLK	O	Table 8 on page 25
83.	LEDDAT	O	Table 8 on page 25

1. Refer to [Table 1](#) for Signal Type definitions.
 2. Pins are 5 V tolerant, unless indicated.
 3. Input must be static; Refer to [Section 3.3.6.2, LED Pins Multiplexed with Configuration Inputs](#), on page 67 for information on pin use.

Table 2 Pins, Numeric Order (Sheet 4 of 7)

Pin	Symbol	Type ^{1,2}	Reference for Full Description
84.	LEDLAT	O	Table 8 on page 25
85.	VCC	—	Table 9 on page 26
86.	GND	—	Table 9 on page 26
87.	PORT1_LED3	O, OD	Table 8 on page 25
88.	PORT1_LED2	O, OD	Table 8 on page 25
89.	PORT1_LED1	O, OD	Table 8 on page 25
90.	GND	—	Table 9 on page 26
91.	PORT2_LED3	O, OD	Table 8 on page 25
92.	PORT2_LED2	O, OD	Table 8 on page 25
93.	PORT2_LED1	O, OD	Table 8 on page 25
94.	GND	—	Table 9 on page 26
95.	PORT3_LED3	O, OD	Table 8 on page 25
96.	PORT3_LED2	O, OD	Table 8 on page 25
97.	PORT3_LED1	O, OD	Table 8 on page 25
98.	GND	—	Table 9 on page 26
99.	PORT4_LED3	O, OD	Table 8 on page 25
100.	PORT4_LED2	O, OD	Table 8 on page 25
101.	PORT4_LED1	O, OD	Table 8 on page 25
102.	RBIAS	A	Table 9 on page 26
103.	GND	—	Table 9 on page 26
104.	TPIP1	AI	Table 6 on page 23
105.	TPIN1	AI	Table 6 on page 23
106.	VCCR	—	Table 9 on page 26
107.	TPOP1	AO	Table 6 on page 23
108.	TPON1	AO	Table 6 on page 23
109.	GND	—	Table 9 on page 26
110.	TPON2	AO	Table 6 on page 23
111.	TPOP2	AO	Table 6 on page 23
112.	VCCT	—	Table 9 on page 26
113.	VCCR	—	Table 9 on page 26
114.	TPIN2	AI	Table 6 on page 23
115.	TPIP2	AI	Table 6 on page 23
116.	GND	—	Table 9 on page 26
117.	GND	—	Table 9 on page 26

1. Refer to [Table 1](#) for Signal Type definitions.
 2. Pins are 5 V tolerant, unless indicated.
 3. Input must be static; Refer to [Section 3.3.6.2, LED Pins Multiplexed with Configuration Inputs](#), on page 67 for information on pin use.

Table 2 Pins, Numeric Order (Sheet 5 of 7)

Pin	Symbol	Type ^{1,2}	Reference for Full Description
118.	TPIP3	AI	Table 6 on page 23
119.	TPIN3	AI	Table 6 on page 23
120.	VCCR	—	Table 9 on page 26
121.	TPOP3	AO	Table 6 on page 23
122.	TPON3	AO	Table 6 on page 23
123.	GND	—	Table 9 on page 26
124.	TPON4	AO	Table 6 on page 23
125.	TPOP4	AO	Table 6 on page 23
126.	VCCT	—	Table 9 on page 26
127.	VCCR	—	Table 9 on page 26
128.	TPIN4	AI	Table 6 on page 23
129.	TPIP4	AI	Table 6 on page 23
130.	GND	—	Table 9 on page 26
131.	GND	—	Table 9 on page 26
132.	TPIP5	AI	Table 6 on page 23
133.	TPIN5	AI	Table 6 on page 23
134.	VCCR	—	Table 9 on page 26
135.	VCCT	—	Table 9 on page 26
136.	TPOP5	AO	Table 6 on page 23
137.	TPON5	AO	Table 6 on page 23
138.	GND	—	Table 9 on page 26
139.	TPON6	AO	Table 6 on page 23
140.	TPOP6	AO	Table 6 on page 23
141.	VCCR	—	Table 9 on page 26
142.	TPIN6	AI	Table 6 on page 23
143.	TPIP6	AI	Table 6 on page 23
144.	GND	—	Table 9 on page 26
145.	GND	—	Table 9 on page 26
146.	TPIP7	AI	Table 6 on page 23
147.	TPIN7	AI	Table 6 on page 23
148.	VCCR	—	Table 9 on page 26
149.	VCCT	—	Table 9 on page 26
150.	TPOP7	AO	Table 6 on page 23
151.	TPON7	AO	Table 6 on page 23

1. Refer to [Table 1](#) for Signal Type definitions.
 2. Pins are 5 V tolerant, unless indicated.
 3. Input must be static; Refer to [Section 3.3.6.2, LED Pins Multiplexed with Configuration Inputs](#), on page 67 for information on pin use.

Table 2 Pins, Numeric Order (Sheet 6 of 7)

Pin	Symbol	Type ^{1,2}	Reference for Full Description
152.	GND	—	Table 9 on page 26
153.	TPON8	AO	Table 6 on page 23
154.	TPOP8	AO	Table 6 on page 23
155.	VCCR	—	Table 9 on page 26
156.	TPIN8	AI	Table 6 on page 23
157.	TPIP8	AI	Table 6 on page 23
158.	GND	—	Table 9 on page 26
159.	TxSLEW_0	I, PD	Table 6 on page 23
160.	TxSLEW_1	I, PD	Table 6 on page 23
161.	PORT5_LED3	O, OD	Table 8 on page 25
162.	PORT5_LED2	O, OD	Table 8 on page 25
163.	PORT5_LED1	O, OD	Table 8 on page 25
164.	GND	—	Table 9 on page 26
165.	PORT6_LED3	O, OD	Table 8 on page 25
166.	PORT6_LED2	O, OD	Table 8 on page 25
167.	PORT6_LED1	O, OD	Table 8 on page 25
168.	GND	—	Table 9 on page 26
169.	PORT7_LED3	O, OD	Table 8 on page 25
170.	PORT7_LED2	O, OD	Table 8 on page 25
171.	PORT7_LED1	O, OD	Table 8 on page 25
172.	GND	—	Table 9 on page 26
173.	VCC	—	Table 9 on page 26
174.	PORT8_LED3	O, OD	Table 8 on page 25
175.	PORT8_LED2	O, OD	Table 8 on page 25
	LEDABGSEL	I ³ , O-OD/OS	Table 8 on page 25
176.	PORT8_LED1	O, OD	Table 8 on page 25
177.	VCC	—	Table 9 on page 26
178.	N/C	—	Table 11 on page 28
179.	GND	—	Table 9 on page 26
180.	VCC	—	Table 9 on page 26
181.	GND	—	Table 9 on page 26
182.	IRQ	O, OD	Table 11 on page 28
183.	AUTOBLINK/	I ³ , O-OD/OS	Table 8 on page 25
	ACT10LED	I ³ , O-OD/OS	Table 8 on page 25

1. Refer to [Table 1](#) for Signal Type definitions.
 2. Pins are 5 V tolerant, unless indicated.
 3. Input must be static; Refer to [Section 3.3.6.2, LED Pins Multiplexed with Configuration Inputs](#), on page 67 for information on pin use.

Table 2 Pins, Numeric Order (Sheet 7 of 7)

Pin	Symbol	Type ^{1,2}	Reference for Full Description
184.	LEDSEL0	I ³ , O-OD/OS	Table 8 on page 25
	ACT_100_LED	I ³ , O-OD/OS	Table 8 on page 25
185.	LEDSEL1	I ³ , O-OD/OS	Table 8 on page 25
	COL10_LED	I ³ , O-OD/OS	Table 8 on page 25
186.	ARBSELECT	I ³ , O-OD/OS	Table 7 on page 24
	COL100_LED	I ³ , O-OD/OS	Table 8 on page 25
187.	MII2_CRS	O	Table 4 on page 19
188.	MII2_COL	O	Table 4 on page 19
189.	GND	—	Table 9 on page 26
190.	VCC	—	Table 9 on page 26
191.	MII2_TXD3	I	Table 4 on page 19
192.	MII2_TXD2	I	Table 4 on page 19
193.	MII2_TXD1	I	Table 4 on page 19
194.	MII2_TXD0	I	Table 4 on page 19
195.	MII2_TXEN	I	Table 4 on page 19
196.	MII2_TXCLK	O	Table 4 on page 19
197.	MII2_TXER	I	Table 4 on page 19
198.	ARBIN	I, PD	Table 7 on page 24
199.	GND	—	Table 9 on page 26
200.	VCC	—	Table 9 on page 26
201.	MMSTRIN	I, PD	Table 5 on page 20
202.	MII2_RXER	O	Table 4 on page 19
203.	MII2_RXCLK	O	Table 4 on page 19
204.	MII2_RXDV	O	Table 4 on page 19
205.	MII2_RXD0	O	Table 4 on page 19
206.	MII2_RXD1	O	Table 4 on page 19
207.	MII2_RXD2	O	Table 4 on page 19
208.	MII2_RXD3	O	Table 4 on page 19
1. Refer to Table 1 for Signal Type definitions. 2. Pins are 5 V tolerant, unless indicated. 3. Input must be static; Refer to Section 3.3.6.2, LED Pins Multiplexed with Configuration Inputs , on page 67 for information on pin use.			

Table 3 MII #1 Signal Descriptions

Pin	Symbol	Type ^{1, 2}	Description
9	MII1_SPD	I PU	Speed Select - MII 1. This signal is sensed at power up, hardware reset, and software reset. Selects operating speed of the respective MII (MAC) interface. High = 100 Mbps. Low = 10 Mbps.
31 32 34 35	MII1_RXD0 MII1_RXD1 MII1_RXD2 MII1_RXD3	O	Receive Data - MII 1. The LXT98x0 Repeater transmits received data to the controller on these outputs. Data is driven on the falling edge of MII1_RXCLK.
30	MII1_RXDV	O	Receive Data Valid - MII 1. Active High signal, synchronous to MII1_RXCLK, indicates valid data on MII1_RXD<3:0>.
29	MII1_RXCLK	O	Receive Clock - MII 1. MII receive clock for expansion port. This is a 2.5 or 25 MHz clock derived from the CLK25 input (refer to Table 11 on page 28).
26	MII1_RXER	O	Receive Error - MII 1. Active High signal, synchronous to MII1_RXCLK, indicates invalid data on MII1_RXD<3:0>.
24	MII1_TXER	I	Transmit Error - MII 1. MII1_TXER is a 100 Mbps-only signal. The MAC asserts this input when an error has occurred in the transmit data stream. The LXT98x0 Repeater responds by sending 'Invalid Code Symbols' on the line.
23	MII1_TXCLK	O	Transmit Clock - MII 1. This is a 2.5 or 25 MHz clock derived from the CLK25 input (refer to Table 11 on page 28).
22	MII1_TXEN	I	Transmit Enable - MII 1. External controllers drive this input High to indicate data is transmitted on the MII1_TXD<3:0> pins. Ground this input if unused.
21 20 19 17	MII1_TXD0 MII1_TXD1 MII1_TXD2 MII1_TXD3	I	Transmit Data - MII 1. External controllers use these inputs to transmit data to the LXT98x0 Repeater. The LXT98x0 Repeater samples MII1_TXD<3:0> on the rising edge of MII1_TXCLK, when MII1_TXEN is High.
14	MII1_COL	O	Collision - MII 1. The LXT98x0 Repeater drives this signal High to indicate a collision occurred.
13	MII1_CRS	O	Carrier Sense - MII 1. Active High signal indicates LXT98x0 Repeater is transmitting or receiving.
<p>1. I = Input, O = Output, I/O = Input/Output, D = Digital, A = Analog, AI = Analog Input, A I/O = Analog Input/Output, OD = Open Drain, OS = Open Source, PD = Pull Down, PU = Pull Up. NC = No Clamp. Pad does not clamp input in the absence of power. 2. Pins are 5 V tolerant, unless indicated.</p>			

Table 4 MII #2 Signal Descriptions

Pin	Symbol	Type ^{1, 2}	Description
18	MII2_SPD	I PU	Speed Select - MII 2. This signal is sensed at power up, hardware reset, and software reset. Selects operating speed of the respective MII (MAC) interface. High = 100 Mbps. Low = 10 Mbps.
205 206 207 208	MII2_RXD0 MII2_RXD1 MII2_RXD2 MII2_RXD3	O	Receive Data - MII 2. The LXT98x0 Repeater transmits received data to the controller on these outputs. Data is driven on the falling edge of MII2_RXCLK.
204	MII2_RXDV	O	Receive Data Valid - MII 2. Active High signal, synchronous to MII2_RXCLK, indicates valid data on MII2_RXD<3:0>.
203	MII2_RXCLK	O	Receive Clock - MII 2. MII receive clock for expansion port. This is a 2.5 or 25 MHz clock derived from the CLK25 input (refer to Table 11 on page 28).
202	MII2_RXER	O	Receive Error - MII 2. Active High signal, synchronous to MII2_RXCLK, indicates invalid data on MII2_RXD<3:0>.
197	MII2_TXER	I	Transmit Error - MII 2. MII2_TXER is a 100 Mbps-only signal. The MAC asserts this input when errors occurs in the transmit data stream. The LXT98x0 Repeater sends 'Invalid Code Symbols' on the line.
196	MII2_TXCLK	O	Transmit Clock - MII 2. This is a 2.5 or 25 MHz clock derived from the CLK25 input (refer to Table 11 on page 28).
195	MII2_TXEN	I	Transmit Enable - MII 2. External controllers drive this input High to indicate data is transmitted on the MII2_TXD<3:0> pins. Ground this input if unused.
194 193 192 191	MII2_TXD0 MII2_TXD1 MII2_TXD2 MII2_TXD3	I	Transmit Data - MII 2. External controllers use these inputs to transmit data to the LXT98x0 Repeater. The LXT98x0 Repeater samples MII2_TXD<3:0> on the rising edge of MII2_TXCLK, when MII2_TXEN is High.
188	MII2_COL	O	Collision - MII 2. The LXT98x0 Repeater drives this signal High to indicate a collision occurred.
187	MII2_CRS	O	Carrier Sense - MII 2. Active High signal indicates LXT98x0 Repeater is transmitting or receiving.
1. I = Input, O = Output, I/O = Input/Output, D = Digital, A = Analog, AI = Analog Input, A I/O = Analog Input/Output, OD = Open Drain, OS = Open Source, PD = Pull Down, PU = Pull Up, NC = No Clamp. Pad does not clamp input in the absence of power. 2. Pins are 5 V tolerant, unless indicated.			

Table 5 Inter-Repeater Backplane Signal Descriptions (Sheet 1 of 3)

Pin	Symbol	Type ^{1, 2}	Description
Common IRB Signals			
39	COMP_SEL	AI	Compatibility Mode Select. 3.3 V on this pin causes the IRCFSBP signals to operate in 3.3 V only mode. 5 V on this pin causes the IR100CFSBP or IR10CFSBP signals to operate in 5 V backwards compatibility mode with legacy LXT98x and LXT91x devices.
100 Mbps IRB Signals			
36	$\overline{\text{IR100CFS}}^3$	A I/O OD	100 Mbps IRB Collision Force Sense. A three-level signal that determines number of active ports on the “logical” repeater. High level (3.3 V) indicates no ports active; Mid level (approx. 1.6 V) indicates one port active; Low level (0 V) indicates more than one port active, resulting in a collision. This signal requires a 215 Ω pull-up resistor, and connects between ICs on the same board.
37	$\overline{\text{IR100CFSBP}}$	A I/O OD	100 Mbps IRB Collision Force Sense - Backplane. This three-level signal functions the same as IR100CFS; however, it connects between ICs with Chip ID = 00, on different boards. IR100CFSBP requires a single 91 Ω pull-up resistor in each stack. This signal can be set in either 5 V or 3.3 V modes by the COMP_SEL pin.
38	$\overline{\text{IR100SNGL}}$	I/O Schmitt PU	100 Mbps Single Driver State. This active Low signal is asserted by the device with Chip ID = 00 when a packet is received from one or more ports. Do not connect this signal between boards.
40	$\overline{\text{IR100COL}}$	I/O Schmitt PU	100 Mbps Multiple Driver State. This active Low signal is asserted by the device with Chip ID = 00 when a packet is being received from more than one port (collision). Do not connect this signal between boards.
41	$\overline{\text{IR100DEN}}$	O OD	100 Mbps IRB Driver Enable. This output provides directional control for an external bidirectional transceiver (74LVT245) used to buffer the 100 Mbps IRB in multi-board applications. It must be pulled up by a 330 Ω resistor. When there are multiple devices on one board, tie all IR100DEN outputs together. If IR100DEN is tied directly to the DIR pin on a 74LVT245, attach the on-board IR100DAT, IR100CLK, and IR100DV signals to the “B” side of the 74LVT245, and connect the off-board signals to the “A” side of the 74LVT245.
42	$\overline{\text{IR100DV}}$	I/O Schmitt OD PU	100 Mbps IRB Data Valid. This active Low signal indicates port activity on the repeater. IR100DV frames the clock and data of the packet on the backplane. This signal requires a 300 Ω pull-up resistor.
43 44 45 48 49	IR100DAT0 IR100DAT1 IR100DAT2 IR100DAT3 IR100DAT4	I/O Tri-state Schmitt PU	100 Mbps IRB Data. These bidirectional signals carry 5-bit data on the 100 Mbps IRB. Data is driven on the falling edge and sampled on the rising edge of IR100CLK. Buffer these signals between boards.
<p>1. I = Input, O = Output, I/O = Input/Output, D = Digital, AI = Analog Input, A I/O = Analog Input/Output, OD = Open Drain, OS = Open Source, PD = Pull Down, PU = Pull Up. Even if the IRB is not used, required pull-up resistors must be installed as listed above. NC = No Clamp. Pad does not clamp input in the absence of power. 2. Pins are 5 V tolerant, unless indicated. 3. IR100CFS is not 5 V tolerant. 4. IR10CFS is not 5 V tolerant.</p>			

Table 5 Inter-Repeater Backplane Signal Descriptions (Sheet 2 of 3)

Pin	Symbol	Type ^{1, 2}	Description
50	IR100CLK	I/O Tri-state Schmitt PD	100 Mbps IRB Clock. This bidirectional, non-continuous, 25 MHz clock is recovered from received network traffic. Schmitt triggering is used to increase noise immunity. This signal must be pulled to VCC when idle. One 1 k Ω pull-up resistor on both sides of a 74LVT245 buffer is recommended.
56	IR100ISO	O	100 Mbps Stack Backplane Isolate. This output allows one LXT98x0 Repeater per board the ability to enable or disable an external bidirectional transceiver (74LVT245). Attach the output to the Enable input of the 74LVT245. The output is driven High (disable) to isolate the 100 Mbps IRB.
10 Mbps IRB Signals			
11	IR10DAT	I/O OD PD	10 Mbps IRB Data. This bidirectional signal carries data on the 10 Mbps IRB. Data is driven and sampled on the rising edge of the corresponding IRCLK. This signal must be pulled High by a 330 Ω resistor. Buffer this signal between boards.
12	IR10CLK	I/O Tri-state Schmitt PD	10 Mbps IRB Clock. This bidirectional, non-continuous, 10 MHz clock is recovered from received network traffic. During idle periods, the output is high-impedance. Schmitt triggering is used to increase noise immunity.
6	$\overline{\text{IR10DEN}}$	O OD	10 Mbps IRB Driver Enable. This output provides directional control for an external bidirectional transceiver (74LVT245) used to buffer the IRBs in multi-board applications. It must be pulled up by a 330 Ω resistor. When there are multiple devices on one board, tie all $\overline{\text{IR10DEN}}$ outputs together. If $\overline{\text{IR10DEN}}$ is tied directly to the DIR pin on a 74LVT245, attach the on-board IR10DAT, IR10CLK and IR10ENA signals to the "B" side of the 74LVT245, and connect the off-board signals to the "A" side of the 74LVT245.
10	$\overline{\text{IR10ENA}}$	I/O OD PU	10 Mbps IRB Enable. This active Low output indicates carrier presence on the IRB. A 330 Ω pull-up resistor is required to pull the $\overline{\text{IR10ENA}}$ output High when the IRB is idle. When there are multiple devices, tie all $\overline{\text{IR10ENA}}$ outputs together. Buffer these signals between boards.
3	$\overline{\text{IR10COL}}$	I/O OD PU	10 Mbps IRB Collision. This output is driven Low to indicate a collision occurred on the 10 Mbps segment. A 330 Ω resistor is required on each board to pull this signal High when there is no collision. Do not connect between boards and do not buffer.
4	$\overline{\text{IR10COLBP}}$	I/O OD	10 Mbps IRB Collision - Backplane. This active Low output has the same function as $\overline{\text{IR10COL}}$, but is used between boards. Attach this signal only from the device with Chip ID = 00 to the backplane or connector, <i>without buffering</i> . The output must be pulled up by one 330 Ω resistor per stack.
2	$\overline{\text{IR10CFS}}$ ⁴	A, I/O OD	10 Mbps IRB Collision Force Sense. This three-state analog signal indicates transmit collision when driven Low. $\overline{\text{IR10CFS}}$ requires a 215 Ω , 1% pull-up resistor. Do not connect this signal between boards and do not buffer.
<p>1. I = Input, O = Output, I/O = Input/Output, D = Digital, AI = Analog Input, A I/O = Analog Input/Output, OD = Open Drain, OS = Open Source, PD = Pull Down, PU = Pull Up. Even if the IRB is not used, required pull-up resistors must be installed as listed above. NC = No Clamp. Pad does not clamp input in the absence of power. 2. Pins are 5 V tolerant, unless indicated. 3. $\overline{\text{IR10CFS}}$ is not 5 V tolerant. 4. $\overline{\text{IR10CFS}}$ is not 5 V tolerant.</p>			

Table 5 Inter-Repeater Backplane Signal Descriptions (Sheet 3 of 3)

Pin	Symbol	Type ^{1, 2}	Description
5	$\overline{\text{IR10CFSBP}}$	A I/O OD	10 Mbps IRB Collision Force Sense - Backplane. Functions the same as IR10CFS, but connects between boards. Attach this signal only from the device with Chip ID = 0 to the backplane or connector, <i>without buffering</i> . This signal requires one 330 Ω , 1% pull-up resistor per stack. This signal can be set for 5 V or 3.3 V modes by the COMP_SEL pin.
80	MACACTIVE	I PD	MAC Active. Active High input allows external ASICs to participate in 10 Mbps IRB. Driving data onto the IRB requires the external ASIC assert MACACTIVE High for one clock cycle, then assert IR10ENA Low. ASIC monitors IR10COL (active Low) for collision. By using MACACTIVE, the repeater—not the MAC—drives the three-level IR10CFS pin.
55	IR10ISO	O	10 Mbps IRB Isolate. By using IR10 ISO, one LXT98x0 Repeater per board can enable or disable an external bidirectional transceiver (74LVT245). Attach the output to the Enable input of the 74LVT245. Driven High (disable) to isolate the 10 Mbps IRB.
81	HOLDCOL	I/O PD	Hold Collision for 10 Mbps mode. This active High signal is driven by the device with Chip ID = 00 to extend a non-local transmit collision to other devices on the same board. Do not attach the HOLDCOL signals from different boards together.
201	MMSTRIN	I PD	Management Master Input. The Management Master (MM) daisy chain ensures collisions are counted correctly in multi-board applications. Attach the MMSTRIN input of each device to the MMSTROUT output of the previous device. Ground MMSTRIN of the first or only device.
64	MMSTROUT	O	Management Master Output. MM daisy chain output. In hot-swap applications, a 1 k Ω - 3 k Ω resistor can be used as a by-pass between MMSTRIN and MMSTROUT.
<p>1. I = Input, O = Output, I/O = Input/Output, D = Digital, AI = Analog Input, A I/O = Analog Input/Output, OD = Open Drain, OS = Open Source, PD = Pull Down, PU = Pull Up. Even if the IRB is not used, required pull-up resistors must be installed as listed above. NC = No Clamp. Pad does not clamp input in the absence of power. 2. Pins are 5 V tolerant, unless indicated. 3. $\overline{\text{IR10CFS}}$ is not 5 V tolerant. 4. IR10CFS is not 5 V tolerant.</p>			

Table 6 Twisted-Pair Port Signal Descriptions

Pin	Symbol	Type ¹	Description		
107, 108 111, 110 121, 122 125, 124 136, 137 140, 139 150, 151 154, 153	TPOP1, TPON1 TPOP2, TPON2 TPOP3, TPON3 TPOP4, TPON4 TPOP5, TPON5 TPOP6, TPON6 TPOP7, TPON7 TPOP8, TPON8	AO	Twisted-Pair Outputs - Ports 1 through 8. These pins are the positive and negative outputs from the respective ports' twisted-pair line drivers. For unused ports, these pins can be left open.		
104, 105 115, 114 118, 119 129, 128 132, 133 143, 142 146, 147 157, 156	TPIP1, TPIN1 TPIP2, TPIN2 TPIP3, TPIN3 TPIP4, TPIN4 TPIP5, TPIN5 TPIP6, TPIN6 TPIP7, TPIN7 TPIP8, TPIN8	AI	Twisted-Pair Inputs - Ports 1 through 8. These pins are the positive and negative inputs to the respective ports' twisted-pair receivers. For unused ports, tie together with 100 Ω resistors and float.		
160 159	TxSLEW_1 TxSLEW_0	I PD	Tx Output Slew Controls 0 and 1. These pins select the TX output slew rate (rise and fall time) as follows:		
			TxSLEW_1	TxSLEW_0	Slew Rate (Rise and Fall Time)
			0	0	2.5 ns
			0	1	3.1 ns
			1	0	3.7 ns
1	1	4.3 ns			
¹ . I = Input, O = Output, I/O = Input/Output, D = Digital, A = Analog, AI = Analog Input, AO = Analog Output, A I/O = Analog Input/Output, OD = Open Drain, OS = Open Source, PD = Pull Down, PU = Pull Up. NC = No Clamp. Pad does not clamp input in the absence of power.					

Table 7 Serial Management Interface Signal Descriptions

Pin	Symbol	Type ^{1, 2,}	Description
57	RECONFIG	I PD	Reconfigure. This input determines whether SERCLK is an input or an output. When RECONFIG is High, the LXT98x0 Repeater drives SERCLK with a 625 kHz output. When RECONFIG is Low, SERCLK is an input to the LXT98x0 Repeater. If the LXT98x0 Repeater detects a Low-to-High transition on RECONFIG, or if RECONFIG is High at power-up, it sends out a "Configuration Change" message (Start Flag with all 0s) on the bus.
63	SER_MATCH	O	Serial Match. The LXT98x0 Repeater device with Chip ID = 00 asserts this active High output whenever it detects a message on the SMI matching the local Hub ID. See Section 2.10, Serial Management I/F, on page 50 .
58	SRX	I PD	Serial Receive. Receive data input for SMI. Must be tied to STX externally. SRX is sampled on the rising edge of SERCLK.
59	STX	O OD	Serial Transmit. Transmit data output for SMI. Must be tied to SRX externally. Data transmitted on STX is compared with data received on SRX. In the event of a mismatch, STX goes to a high impedance state. STX is driven on the falling edge of SERCLK.
60	SERCLK	I/O Tri-state PD	Serial Clock. Clock for SMI. Depending on RECONFIG, this pin is either a 625 kHz output or a 0 to 2 MHz input.
198	ARBIN	I PD	Arbitration In/Out. Used with Chain Arbitration. If used, tie ARBIN to ARBOUT of the previous device. ARBIN at the top of the daisy chain can be connected to ground or to ARBOUT of the SCC. If unused, tie ARBIN High.
65	ARBOUT	O	
186	ARBSELECT	I ³ O - OD/OS	Arbitration Mode Select - Input. 0 = PROM based, 1 = chain based. This configuration pin also functions as the COL100 LED output (refer to Note 3 below and to Table 8).
67	$\overline{\text{MGR_PRES}}$	I PU	Manager Present. This signal is sensed at power up, hardware reset, and software reset. If the signal is High, it indicates no local manager is present, and the LXT98x0 Repeater enables all ports and sets all LEDs to operate in "hardware mode". If it is Low, indicating a manager is present, the LXT98x0 Repeater disables all ports, pending control of network manager.
<p>1. I = Input, O = Output, I/O = Input/Output, D = Digital, A = Analog, AI = Analog Input, A I/O = Analog Input/Output, OD = Open Drain, OS = Open Source, PD = Pull Down, PU = Pull Up. NC = No Clamp. Pad does not clamp input in the absence of power. 2. Pins are 5 V tolerant, unless indicated. 3. Input must be static. Refer to Section 3.3.6.2, LED Pins Multiplexed with Configuration Inputs, on page 67 for information on pin use.</p>			

Table 8 LED Signal Descriptions (Sheet 1 of 2)

Pin	Symbol	Type ^{1, 2}	Description
184 185	LEDSEL0 LEDSEL1	I ³ O - OD/OS	LED Mode Select - Input. See Note 3 in footer below. 00 = Mode 1, 01 = Mode 2, 10 = Mode 3, 11 = Mode 4 These pins are shared with the LEDACT100, LEDCOL10 outputs.
175	LEDABGSEL	I ³ O - OD/OS	LED Activity Bar Graph Mode Select - Input. See Note 2 in footer below. 0 = Base-10 Mode, 1 = Base-2 Mode Refer to "Activity Graph LEDs" on page 59. This pin is shared with the Port8_LED2 output.
183	$\overline{\text{AUTOBLINK}}$	I ³ O - OD/OS	LED Blink Mode Select - Input. See Note 3 in footer below. 0 = Auto blink on, 1 = Auto blink off This pin is shared with the LEDACT10 output.
83	LEDDAT	O	LED Data. Serial data stream that is shifted into external Serial-to-Parallel LED drivers. See Section 2.7.4, Serial LED Interface, on page 37 .
84	LEDLAT	O	LED Latch. Parallel load clock for external Serial-to-Parallel LED drivers. See Section 2.7.4, Serial LED Interface, on page 37 .
82	LEDCLK CFG_CLK	O	LED Clock. Serial data stream clock for external Serial-to-Parallel LED drivers. See Section 2.7.4, Serial LED Interface, on page 37 . Configuration Bus Clock. Refer to CFG_DT and CFG_LD pin description in Table 11 on page 28 . CFG_CLK pulses whenever a read of the Serial Configuration Register occurs. See Section 2.12, Serial Configuration Interface, on page 58 .
176 171 167 163 101 97 93 89	PORT8_LED1 PORT7_LED1 PORT6_LED1 PORT5_LED1 PORT4_LED1 PORT3_LED1 PORT2_LED1 PORT1_LED1	O OD	LED Driver 1 - Ports 1 through 8. Programmable LED driver. Active Low. See Section 2.7.5, Direct Drive LEDs, on page 40 . Port8_LED1 must be pulled High via a 100–500kΩ resistor if LED circuit not used.
175 170 166 162 100 96 92 88	PORT8_LED2 PORT7_LED2 PORT6_LED2 PORT5_LED2 PORT4_LED2 PORT3_LED2 PORT2_LED2 PORT1_LED2	O OD	LED Driver 2 - Ports 1 through 8. Programmable LED driver. Active Low. See Section 2.7.5, Direct Drive LEDs, on page 40 . The Port8_LED2 pin is shared with the LEDABGSEL configuration input.
<p>1. I = Input, O = Output, I/O = Input/Output, D = Digital, A = Analog, AI = Analog Input, A I/O = Analog Input/Output, OD = Open Drain, OS = Open Source, PD = Pull Down, PU = Pull Up. Even if the IRB is not used, required pull-up resistors must be installed as listed above. NC = No Clamp. Pad does not clamp input in the absence of power. 2. Pins are 5 V tolerant, unless indicated. 3. Input must be static; Refer to Section 3.3.6.2, LED Pins Multiplexed with Configuration Inputs, on page 67 for information on pin use.</p>			

Table 8 LED Signal Descriptions (Sheet 2 of 2)

Pin	Symbol	Type ^{1, 2}	Description
174 169 165 161 99 95 91 87	PORT8_LED3 PORT7_LED3 PORT6_LED3 PORT5_LED3 PORT4_LED3 PORT3_LED3 PORT2_LED3 PORT1_LED3	O OD	LED Driver 3 - Ports 1 through 8. Programmable LED driver. Active Low. See Section 2.7.5, Direct Drive LEDs , on page 40. Port8_LED3 must be pulled High via a 100–500 kΩ resistor if LED circuit not used.
185	COL10_LED	I O - OD/OS	10 Mbps Collision LED Driver. Active output indicates collision on 10 Mbps segment. This pin is shared with the LEDSEL1 configuration input.
186	COL100_LED	I O - OD/OS	100 Mbps Collision LED Driver. Active output indicates collision on 100 Mbps segment. This pin is shared with the ARBSELECT configuration input (refer to Table 7 on page 24 and to Note 3 below).
183	ACT10_LED	I O - OD/OS	10 Mbps Activity LED Driver. Active output indicates activity on 10 Mbps segment. This pin is shared with the AUTOBLINK configuration input (refer to Note 3 below).
184	ACT100_LED	I O - OD/OS	100 Mbps Activity LED Driver. Active output indicates activity on 100 Mbps segment. This pin is shared with the LEDSEL0 configuration input (refer to Note 3 below).
<p>1. I = Input, O = Output, I/O = Input/Output, D = Digital, A = Analog, AI = Analog Input, A I/O = Analog Input/Output, OD = Open Drain, OS = Open Source, PD = Pull Down, PU = Pull Up. Even if the IRB is not used, required pull-up resistors must be installed as listed above. NC = No Clamp. Pad does not clamp input in the absence of power. 2. Pins are 5 V tolerant, unless indicated. 3. Input must be static; Refer to Section 3.3.6.2, LED Pins Multiplexed with Configuration Inputs, on page 67 for information on pin use.</p>			

Table 9 Power Supply and Indication Signal Descriptions (Sheet 1 of 2)

Pin	Symbol	Type ^{1, 2}	Description
8, 16, 28, 47, 61, 74, 76, 77, 85, 173, 177, 180, 190, 200	VCC	—	Power Supply Inputs. Each of these pins must be connected to a common +3.3 VDC power supply. A de-coupling capacitor to digital ground should be supplied for every one of these pins.
106, 113, 120, 127, 134, 141, 148, 155	VCCR	—	Analog Supply Inputs - Receive. Each of these pins must be connected to a common +3.3 VDC power supply. A de-coupling capacitor to GND should be supplied for every one of these pins. Use ferrite beads to create a separate analog VCC plane.
112, 126, 135, 149	VCCT	—	Analog Supply Inputs - Transmit. Each of these pins must be connected to a common +3.3 VDC power supply. A de-coupling capacitor to GND should be supplied for every one of these pins. Use ferrite beads to create a separate analog VCC plane.
<p>1. I = Input, O = Output, I/O = Input/Output, D = Digital, A = Analog, AI = Analog Input, A I/O = Analog Input/Output, OD = Open Drain, OS = Open Source, PD = Pull Down, PU = Pull Up. NC = No Clamp. Pad does not clamp input in the absence of power. 2. Pins are 5 V tolerant, unless indicated.</p>			

Table 9 Power Supply and Indication Signal Descriptions (Sheet 2 of 2)

Pin	Symbol	Type ^{1, 2}	Description
1, 7, 15, 27, 46, 62, 75, 86, 90, 94, 98, 103, 109, 116, 117, 123, 130, 131, 138, 144, 145, 152, 158, 164, 168, 172, 179, 181, 189, 199	GND	—	Ground. Connect each of these pins to system ground plane.
102	RBIAS	A	RBIAS. Used to provide bias current for internal circuitry. The 100 μ A bias current is provided through an external 22.1 k Ω , 1% resistor to GND.
79	RPS Pres	I PD	Redundant Power Supply Present. Active High input indicates presence of redundant power supply. Tie Low if not used.
78	RPS Fault	I PU	Redundant Power Supply Fault. Active Low input indicates redundant power supply fault. The state of this input is reflected in the RPS_LED output (refer to LED section). Tie High if not used.
<p>1. I = Input, O = Output, I/O = Input/Output, D = Digital, A = Analog, AI = Analog Input, A I/O = Analog Input/Output, OD = Open Drain, OS = Open Source, PD = Pull Down, PU = Pull Up. NC = No Clamp. Pad does not clamp input in the absence of power.</p> <p>2. Pins are 5 V tolerant, unless indicated.</p>			

Table 10 PROM Interface Signal Descriptions

Pin	Symbol	Type ^{1, 2}	Description
68	PROM_CLK	I/O Tri-State PD	PROM Clock. 1 MHz clock for reading PROM data (Chip ID = 00). If a PROM is not used, this pin must be tied Low. All devices should be connected together. PROM_CLK is driven only by the device with ChipID = 00. (Sensed by other devices.)
69	PROM_CS	O Tri-State	PROM Chip Select. Selects PROM. Active High signal driven only when Chip ID = 00.
70	PROM_DTOUT	O Tri-State	PROM Data Output. Selects read instruction for PROM. Active High signal driven only when ChipID = 00. All devices should be connected together. PROM_CLK is driven only by the device with ChipID = 00. (Sensed by other devices.)
71	PROM_DTIN	I PD	PROM Data Input. If a PROM is not used, this input can be tied Low or High.
<p>1. I = Input, O = Output, I/O = Input/Output, D = Digital, A = Analog, AI = Analog Input, A I/O = Analog Input/Output, OD = Open Drain, OS = Open Source, PD = Pull Down, PU = Pull Up. NC = No Clamp. Pad does not clamp input in the absence of power.</p> <p>2. Pins are 5 V tolerant, unless indicated.</p>			

Table 11 Miscellaneous Signal Descriptions

Pin	Symbol	Type ^{1, 2}	Description
53	$\overline{\text{RESET}}$	I Schmitt	Reset. This active Low input causes internal circuits, state machines and counters to reset (address tracking registers do not reset). On power-up, devices should not be brought out of reset until the power supply stabilizes to 3.3 V. When there are multiple devices, it is recommended all be supplied by a common reset driven by an 'LS14 or similar device.
54	CLK25	I Schmitt	25 MHz system clock. Refer to Table 29 on page 73 for clock requirements.
72 73	CHIPID0 CHIPID1	I PD	Chip ID. These pins assign unique Chip IDs to as many as four devices on a single board. One device on each board must be assigned ChipID = 00. See Section 2.10, Serial Management I/F, on page 50 .
33	CONFIG(0) / CFG_DT	I PD	Configuration Register Input 0. The CONFIG[1:0] inputs allow the user to store system-specific information (board type, plug-in cards, status, etc.) in the Serial Configuration Register (hex address AC). This register may be read remotely through the Serial Management Interface (SMI). Configuration Bus Data. Used in conjunction with CFG_CLK and CFG_LD, these pins provide an expansion capability for the functionality of CONFIG[1:0]. Using an external Parallel-to-Serial device, up to 8 Configuration inputs can be brought to the SMI for user access. The Configuration Mode Select bit (Bit 14) in the Repeater Configuration Register is used to choose between CONFIG[1:0] and CFG bus modes. (See Table 75 on page 111 .)
25	CONFIG(1) / CFG_LD	I/O PD	Configuration Register Input 1. The CONFIG[1:0] inputs allow the user to store system-specific information (board type, plug-in cards, status, etc.) in the Repeater Serial Configuration register. This register may be read remotely through the Serial Management Interface (SMI). Configuration Bus Load (active Low). Used in conjunction with CFG_CLK and CFG_DT, this active Low pin provides an expansion capability for the functionality of CONFIG[1:0]. Using an external Parallel-to-Serial device, up to 8 Config. inputs can be brought to the SMI for user access. The Configuration Mode Select bit (Bit 14) in the Repeater Configuration Register is used to choose between CONFIG[1:0] and CFG bus modes. See Table 75 on page 111 .)
82	CFG_CLK/ LEDCLK	O	Configuration Bus Clock. Refer to CFG_DT and CFG_LD pin description. CFG_CLK pulses whenever a read of the Serial Configuration Register occurs. Refer to Section 2.12, Serial Configuration Interface, on page 58 . LED Clock. Serial data stream clock for external Serial-to-Parallel LED drivers. Refer to Table 8 for details.
182	$\overline{\text{IRQ}}$	O OD	Interrupt request. Active Low interrupt. Refer to register section for criteria and clearing options. Requires an external pull-up resistor.
51, 52, 66,178	NC	—	No Connects. Leave these pins unconnected.
<p>1. I = Input, O = Output, I/O = Input/Output, D = Digital, A = Analog, AI = Analog Input, A I/O = Analog Input/Output, OD = Open Drain, OS = Open Source, PD = Pull Down, PU = Pull Up. NC = No Clamp. Pad does not clamp input in the absence of power.</p> <p>2. Pins are 5 V tolerant, unless indicated.</p>			

2.0 Functional Description

2.1 Introduction

As a fully integrated IEEE 802.3 compliant repeater capable of 10 Mbps and 100 Mbps operation, the LXT98x0 Repeater is a versatile device allowing great flexibility in Ethernet design solutions. Figure 3 shows a typical application. Refer to Section 3.0, *Application Information*, on page 60 for specific circuit implementations.

This multi-port repeater provides six (LXT9860 Repeater) or eight (LXT9880 Repeater) 10BASE-T/100BASE-TX ports. In addition, each device also provides two Media Independent Interface (MII) expansion ports that may be connected to 10/100 MACs.

The LXT98x0 Repeater provides two repeater state machines and two Inter-Repeater Backplanes (IRB) on a single chip—one for 10 Mbps and one for 100 Mbps operation. The 100 Mbps repeater meets IEEE 802.3 Class II requirements. Each port's operating speed may be selected independently. The auto-negotiation capability of the LXT98x0 Repeater allows it to communicate with connected nodes and configure itself accordingly.

The LXT98x0 Repeater supports RMON by providing on-chip counters and hardware assistance for a fully managed environment. The segmented backplane simplifies dual-speed operation, and allows multiple devices to be stacked and function as one logical Class II repeater. Up to 240 ports (192 TP ports and 48 MII ports) can be supported in a single stack.

Figure 3 Typical LXT988x Managed Repeater Architectures

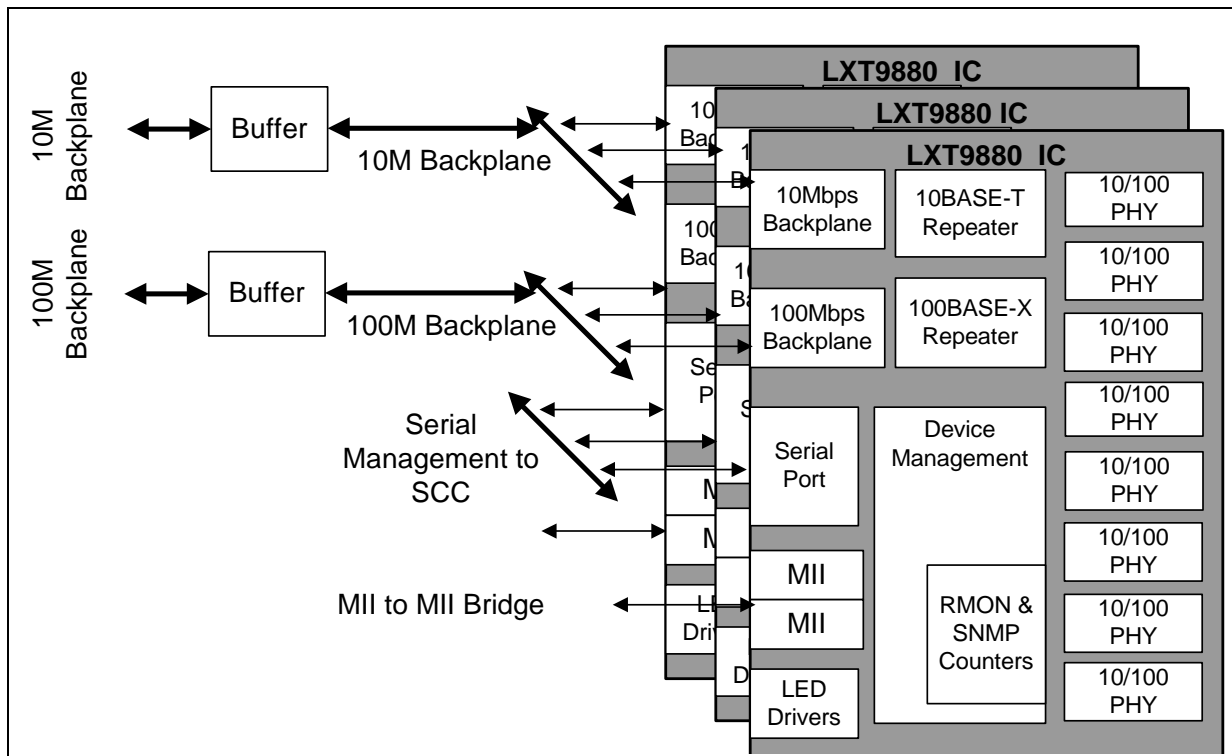

2.2 Port Configuration

The LXT98x0 Repeater powers up in auto-negotiation mode for all twisted-pair ports. Software can monitor or change the configuration through the PHY Port Control Register.

2.2.1 Auto-Negotiation

All TP ports on power up are configured to establish its link via auto-negotiation. The port and its link partner establish link conditions by exchanging Fast Link Pulse (FLP) bursts. Each FLP burst contains 16 bits of data advertising the port's capabilities. The FLP bursts sent by the port are maintained in its auto-negotiation advertisement register ([Table 71 on page 109](#)). The link partner's abilities are stored in the auto-negotiation link partner register ([Table 66 on page 106](#)). Status can be observed in the respective auto-negotiation status register ([Table 65 on page 106](#)). Each port has its own advertisement, link partner advertisement, auto-negotiation expansion, auto-negotiation status registers, and control register.

The advertisement register is read-only, except for bits 5, 7, and 13. The LXT98x0 Repeater can advertise 100 Mbps half-duplex and/or 10 Mbps half-duplex; it never advertises full duplex.

If the link partner does not support auto-negotiation, the LXT98x0 Repeater determines link state by listening for 100 Mbps IDLE symbols or 10 Mbps link pulses. If it detects either of these signals, it configures the port and updates the status registers appropriately.

2.2.2 Forced Operation

A port can be directly configured to operate in either 100BASE-TX or 10BASE-T. When a port is configured for forced operation, it immediately operates in the selected mode. All links are established as half-duplex only. As a repeater, the LXT98x0 Repeater cannot support full-duplex operation.

2.2.3 Changing Port Speed - Forced

To force a port speed change while operating, the following sequence is required:

- Disable the port(s) to be changed.
- Set PHY Port Control Register to desired speed.
- Perform a Repeater Reset (at Register 144; see [Table 82 on page 115](#). The LXT98x0 Repeater does not read hardware configuration pins).
- Re-enable the port(s).

Note: Forcing a speed change on any port requires a Repeater Reset.

2.2.4 Link Establishment and Port Connection

Once a port establishes link, the LXT98x0 Repeater automatically connects it to the appropriate repeater state machine. If link loss is detected, the port returns to the auto-negotiation state.

2.2.5 MII Port Configuration

These ports can be set via hardware tie ups/downs to be either 10 Mbps or 100 Mbps. The statistics for these ports are the same as for the other 10/100 ports, except Isolation, Partition, and Symbol Error.

2.3 Interface Descriptions

The LXT9880 Repeater and LXT9860 Repeater devices provide eight and six network interface ports, respectively. Each port provides a twisted-pair interface. The twisted-pair interface directly supports 100BASE-TX and 10BASE-T. Ethernet applications and fully complies with IEEE 802.3 standards. A common termination circuit is used.

2.3.1 Twisted-Pair Interface

The LXT98x0 Repeater pinout is optimized for dual-height RJ-45 connectors. The twisted-pair interface for each port consists of two differential signal pairs — one for transmit and one for receive. The transmit signal pair is TPOP/TPON, the receive signal pair is TPIP/TPIN.

The transmitter requires magnetics with 1:1 turns ratio. The center tap of the primary side of the transmit winding must be tied to a quiet VCC for proper operation. When the twisted-pair interface is disabled, the transmitter outputs are tri-stated.

The receiver requires magnetics with a 1:1 turns ratio, and a load of 100 Ω . When the twisted-pair port is enabled, the receiver actively biases its inputs to approximately 2.8 V. When the twisted-pair interface is disabled, no biasing is provided. A 4 k Ω load is always present across the TPIP/TPIN pair.

When used in 100BASE-TX applications, the LXT98x0 Repeater sends and receives a continuous, scrambled 125Mbaud MLT-3 waveform on this interface. In the absence of data, IDLE symbols are sent and received in order to maintain the link.

When used in 10BASE-T applications, the LXT98x0 Repeater sends and receives a non-continuous, 10 Mbaud Manchester-encoded waveform. To maintain link during idle periods, the LXT98x0 Repeater sends link pulses every 16 ms, and expects to receive them every 10 to 20ms. Each 10BASE-T port automatically detects and sends link pulses, and disables its transmitter if link pulses are not detected. Each receiver can also be configured to ignore link pulses, and leave its transmitter enabled all the time (link pulse transmission cannot be disabled). Each 10BASE-T port can detect and automatically correct for polarity reversal on the TPIP/N inputs. The 10BASE-T interface provides integrated filters. These filters facilitate low-cost stack designs to meet EMI requirements.

2.3.2 Media Independent Interface

The LXT98x0 Repeater has two identical MII interfaces. The MII has been designed to allow expansion to a Media Access Controller (MAC) as shown in [Figure 4](#). This interface is not MDIO/MDC capable. Management is provided via a serial controller interface. These MII ports can be set via hardware tie ups/downs to be either 10 Mbps or 100 Mbps. The statistics kept for these ports are the same as for the other 10/100 ports, except Isolation, Partition, and Symbol Error. These ports are not the full MII drive strength and are intended only for point-to-point links. Serial terminations are recommended.

Figure 4 MII Interface

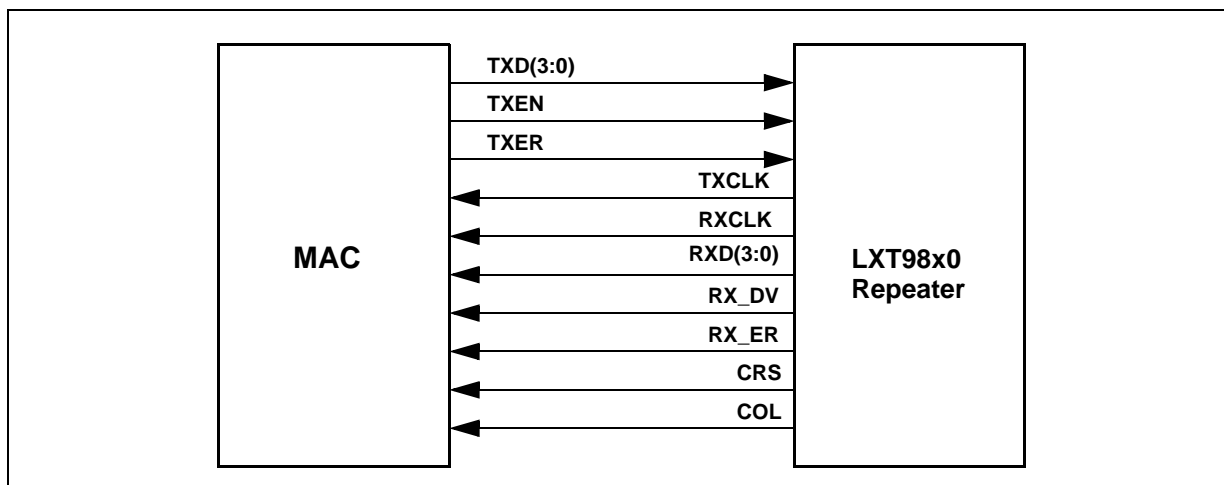

2.3.3 Serial Management Interface

The Serial Management Interface (SMI) provides system access to the status, control and statistic gathering abilities of the LXT98x0 Repeater. This interface allows multiple devices to be managed from a common line, and uses the minimum number of signals (2) for ease of stack design.

The interface itself consists of two digital NRZ signals — clock and data. Refer to [Table 7 on page 24](#) for SMI pin assignments and signal descriptions. Data is framed into HDLC-like packets, with a start/stop flag, header and CRC field for error checking. Zero-bit insertion/removal is used. The interface can operate at any speed from 0 to 2 MHz. (“0 MHz” means the clock need not be continuous. It can be started, stopped, or restarted, provided sixteen 1s in a row are allowed between management packets.)

Address assignment is provided via one of two arbitration mechanisms which are activated whenever the device is powered up or reset/reconfigured. Refer to [Section 2.10, Serial Management I/F, on page 50](#).

2.3.4 Serial PROM Interface

The serial PROM interface allows the loading of optional information unique to each board. Items such as serial number or date of manufacture can be placed in the serial PROM, which is also used in the address arbitration process. See [Section 2.11, Serial PROM Interface, on page 57](#).

2.4 Repeater Operation

The LXT98x0 Repeater contains two internal repeater state machines — one operating at 10 Mbps and the other at 100 Mbps. The LXT98x0 Repeater automatically switches each port to the correct repeater, once the operational state of that port has been determined. Each repeater connects all ports configured to the same speed (including the MII), and the corresponding Inter-Repeater Backplane. Both repeaters perform the standard jabber and partition functions.

2.4.1 100 Mbps Repeater Operation

The LXT98x0 Repeater contains a complete 100 Mbps Repeater State Machine (100RSM) that is fully IEEE 802.3 Class II compliant. Any port configured for 100 Mbps operation is automatically connected to the 100 Mbps Repeater. This includes any of the eight media and two MII ports configured for 100 Mbps operation.

The 100 Mbps RSM has its own Inter-Repeater Backplane (100IRB). Multiple LXT98x0 Repeaters can be cascaded on the 100IRB and operate as one repeater segment. Data from any port is forwarded to all other ports in the cascade. The 100IRB is a 5-bit symbol-mode interface. It is designed to be stackable.

The LXT98x0 Repeater maintains a complete set of statistics for its local 100 Mbps repeater segment. These are accessible through the high-speed serial management interface.

The LXT98x0 Repeater performs the following 100 Mbps repeater functions:

- Signal amplification, wave-shape restoration, and data-frame forwarding.
- SOP, SOJ, EOP, EOJ delay < 46BT; class II compliant.
- Collision Enforcement. During a 100 Mbps collision, the LXT98x0 Repeater drives a 0101 jam signal (encoded as Data 5 on TX links) to all ports until the collision ends. There is no minimum enforcement time.
- Partition. The LXT98x0 Repeater partitions any port that participates in excess of 60 consecutive collisions or one long collision approximately 575.2 μ s long. Once partitioned, the LXT98x0 Repeater monitors and transmits to the port, but does not repeat data received from the port until it un-partitions.
- Un-partition. The LXT98x0 Repeater supports two un-partition algorithms:
 - The alternative un-partition algorithm (default), which complies with IEEE specification 802.3aa un-partitions a port on *either* transmit or receive of at least 450-560 bits without collision.
 - The normal algorithm, which complies with the IEEE specification 802.3u, is available through the management interface. This algorithm un-partitions a port only when data is transmitted to the port for 450-560 bit times without a collision.
- Isolate. The LXT98x0 Repeater isolates any port receiving more than two successive false carrier events. A false carrier event is a packet that does not start with a /J/K symbol pair. Note: this is not the same function as the 100IRB isolate function, which involves isolating the backplane.
- Un-isolate. The LXT98x0 Repeater un-isolates a port that remains in the IDLE state for 33000 +/- 25% BT or that receives a valid frame at least 450-500 BT in length.
- /T/R generation. The LXT98x0 Repeater can insert a /T/R symbol pair (End-of-Stream Delimiter) on any incoming packet that does not include one. This feature is optional, and is enabled through the management interface.
- Jabber. The LXT98x0 Repeater ignores any receiver remaining active for more than 57,500 bit times. The LXT98x0 Repeater exits this state when either one of the following conditions is met:
 - On power-up reset
 - When carrier is no longer detected

Note: The Isolate, Partition, and Symbol Error functions do not apply to MII ports.

2.4.2 10 Mbps Repeater Operation

The LXT98x0 Repeater contains a complete 10 Mbps Repeater State Machine (10RSM) that is fully IEEE 802.3 compliant. Any port configured for 10 Mbps operation is automatically connected to the 10 Mbps Repeater. This includes any of the media and MII ports configured for 10 Mbps operation.

The 10RSM has its own Inter-Repeater Backplane (10IRB). Multiple LXT98x0 Repeaters can be cascaded on the 10IRB and operate as one repeater segment. Data from any port is forwarded to all other ports in the cascade.

The LXT98x0 Repeater maintains a complete set of statistics on its 10 Mbps repeater segment. These are accessible through the high-speed serial management interface.

The LXT98x0 Repeater performs the following 10 Mbps repeater functions:

- Signal amplification, wave-shape restoration, and data-frame forwarding.
- Preamble regeneration. All outgoing packets have a minimum 56-bit preamble and 8-bit SFD.
- SOP, SOJ, EOP, EOJ delays meet IEEE 802.3 section 9.5.5 and 9.5.6 requirements.
- Collision Enforcement. During a 10 Mbps collision, the LXT98x0 Repeater drives a jam signal ("1010") to all ports for a minimum of 96 bit times until the collision ends.
- Partition. The LXT98x0 Repeater partitions any port in excess of 31 consecutive collisions. Once partitioned, the LXT98x0 Repeater continues monitoring and transmitting to the port, but does not repeat data received from the port until it properly un-partitions. (Also partitions for excessive length of a collision.)
- Un-partition. The algorithm, which complies with the IEEE 802.3 specification, un-partitions a port when data can be either received or transmitted from the port for 450-560 bit times without a collision on that port.
- Jabber. The LXT98x0 Repeater asserts a minimum-IFG idle period when a port transmits for longer than 40,000 to 75,000 bit times.

2.5 Management Support

2.5.1 Configuration and Status

The LXT98x0 Repeater provides management control and visibility of the following functions:

- Counter Reset and Zeroing
- Auto-negotiation (Control, Status, Advertisement, Link Partner, and Expansion)
- Device and Board Configuration
- LED Functions
- Source Address Tracking (per port)
- Source Address Matching (per chip)
- Device/Revision ID

2.5.2 SNMP and RMON Support

The LXT98x0 Repeater provides SNMP and RMON support through its statistics gathering function. Statistics are gathered on all packets flowing through the device for each of the ports, including the MII. The LXT98x0 Repeater maintains statistics for both the entire 10 Mbps and 100 Mbps repeaters, independent of the speed setting of the MII ports. All statistics are stored in 32- or 64-bit registers. Per-port counters include:

Readable Frames	Readable Octets	FCS Errors
Alignment Errors	FramesTooLong	ShortEvents
Runts	Collisions	LateEvents
VeryLongEvents	DataRateMismatch	AutoPartitions
Broadcast	Multicast	SA Changes
Isolates	Symbol Errors	

2.5.3 Source Address Management

The LXT98x0 Repeater provides two source address management functions per port: source address tracking and source address matching. These functions allow a network manager to track source addresses at each port, or to identify any port sourcing a particular address.

2.6 Requirements

2.6.1 Power

The LXT98x0 Repeater has four types of +3.3 V power supply input pins: two digital (VCC, GND) and two analog (VCCR, VCCT). These inputs may be supplied from a single source. Ferrite beads should be used to separate the analog and digital planes. These supplies should be as clean as possible.

Each supply input should be decoupled to ground. Refer to [Table 9 on page 26](#) for power and ground pin assignments, and to the [Section 3.1, General Design Guidelines, on page 60](#).

2.6.2 Clock

A stable, external 25 MHz reference clock source (TTL) is required to the CLK25 pin. The reference clock is used to generate transmit signals and recover receive signals. A crystal-based clock is recommended over a derived clock (i.e., PLL-based) to minimize transmit jitter. Refer to [Table 26 on page 65](#) for a list of recommended oscillators and to [Table 29 on page 73](#) for clock timing requirements.

2.6.3 Bias Resistor

The RBIAS input requires a 22.1 k Ω , 1% resistor connected to ground.

2.6.4 Reset

At power-up, the reset input must be held Low until VCC reaches at least 3.15 V. A buffer should be used to drive reset if there are multiple LXT98x0 Repeater devices. The clock must be active.

Software and hardware resets are identical. Refer to [Table 74 on page 110](#) and [Table 83 on page 115](#) for Software Reset details.

2.6.5 PROM

Although not required, an external, auto-incrementing 48-bit PROM can be used for two purposes:

- Support the PROM-based address arbitration scheme on the Serial Management Interface (See [Section 2.10.3.2, PROM Arbitration Mechanism, on page 56.](#))
- Assign a unique ID and upload configuration data to all LXT98x0 Repeaters on a board

Multiple devices on the same board can share a single common PROM. The LXT98x0 Repeater with ChipID = 00 actively reads the PROM at power-up; all other LXT98x0 Repeaters “listen in”. If PROM arbitration is not used, the PROM data input signal must be tied either High or Low. (See [Section 2.11, Serial PROM Interface, on page 57.](#))

2.6.6 Chip ID

Each cascaded LXT98x0 Repeater requires a unique 2-bit Chip ID value. The Serial Management Interface (SMI) identifies each IC by ChipID. One LXT98x0 Repeater on each board must be assigned ChipID = 00. In the Header Field, the Chip Address is defined by three bits. The Most Significant Bit (MSB) = 0; the value of the other two bits is set by pins. Refer to [Section 2.10, Serial Management I/F, on page 50.](#)

2.6.7 Management Master I/O Link

In multiple device applications, the Management Master daisy chain (MMSTRIN/MMSTROUT) ensures that collisions are counted correctly. Connect the MMSTRIN input to the MMSTROUT output of the previous device when cascading and stacking. Ground the MMSTRIN input of the first or only device. In hot-swap applications, resistive bypassing can be used with a 1 - 3 kΩ value.

2.6.8 IRB Bus Pull-ups

Even when the LXT98x0 Repeater is used in a stand-alone configuration, pull-up resistors are required on the IRB signals listed. See [Figure 30 on page 72](#) and [Figure 31 on page 72](#) for sample circuits.

<u>100 Mbps IRB</u>	<u>10 Mbps IRB</u>
IR100CFS	IR10DAT
IR100CFSBP	IR10ENA
IR100DV	IR10COL
IR100CLK	IR10CFS
	IR10COLBP
	IR10CFSBP

2.7 LED Operation

The LXT98x0 Repeater drives the most commonly used LEDs directly (see [Section 2.7.5, Direct Drive LEDs, on page 40](#)). The less frequently used LEDs are optionally driven via a serial bus to inexpensive Serial-to-Parallel devices (see “Serial LEDs” on this page).

2.7.1 LEDs at Start-up

For approximately 2 seconds after the LXT98x0 Repeater is reset, all LEDs are driven to the ON state. This start-up routine is an LED check.

2.7.2 LED Event Stretching

Short lived LED status events are stretched so they may be observed by the human eye. Refer to the LED1, 2, 3 Modes section for stretching specifics.

2.7.3 LED Blink Rates

Two programmable blink rates are provided. The default period for the slow blink rate is 1.6s. The default period is 0.4s for the fast blink rate. These rates may be changed via the LED Timer Control Register. The slow blink rate is defined by the upper 8 bits and the fast blink rate is defined by the lower 8 bits of the LED Timer Control Register. Refer to [Section 5.8.5, LED Timer Control Register, on page 114](#) for details.

Figure 5 LED Blink Rates

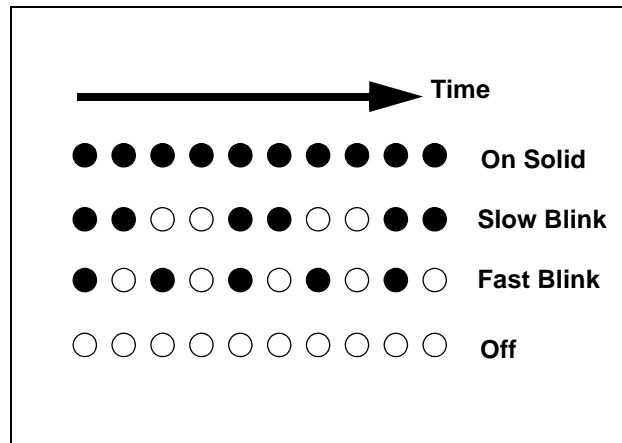

2.7.4 Serial LED Interface

The LXT98x0 Repeater provides a serial interface to drive additional LEDs via external 8-bit Serial-to-Parallel converters. A maximum of 30 LEDs can be driven, using four S/P devices. Collision10/100, Activity10/100 status indications are output on multiplexed configuration pins and are duplicated on the Serial Port. (See [Section 3.3.6.2, LED Pins Multiplexed with Configuration Inputs, on page 67](#).)

2.7.4.1 Serial Shifting

Figure 6 shows the Serial LED shift loading.

Figure 6 Serial LED Shift Loading

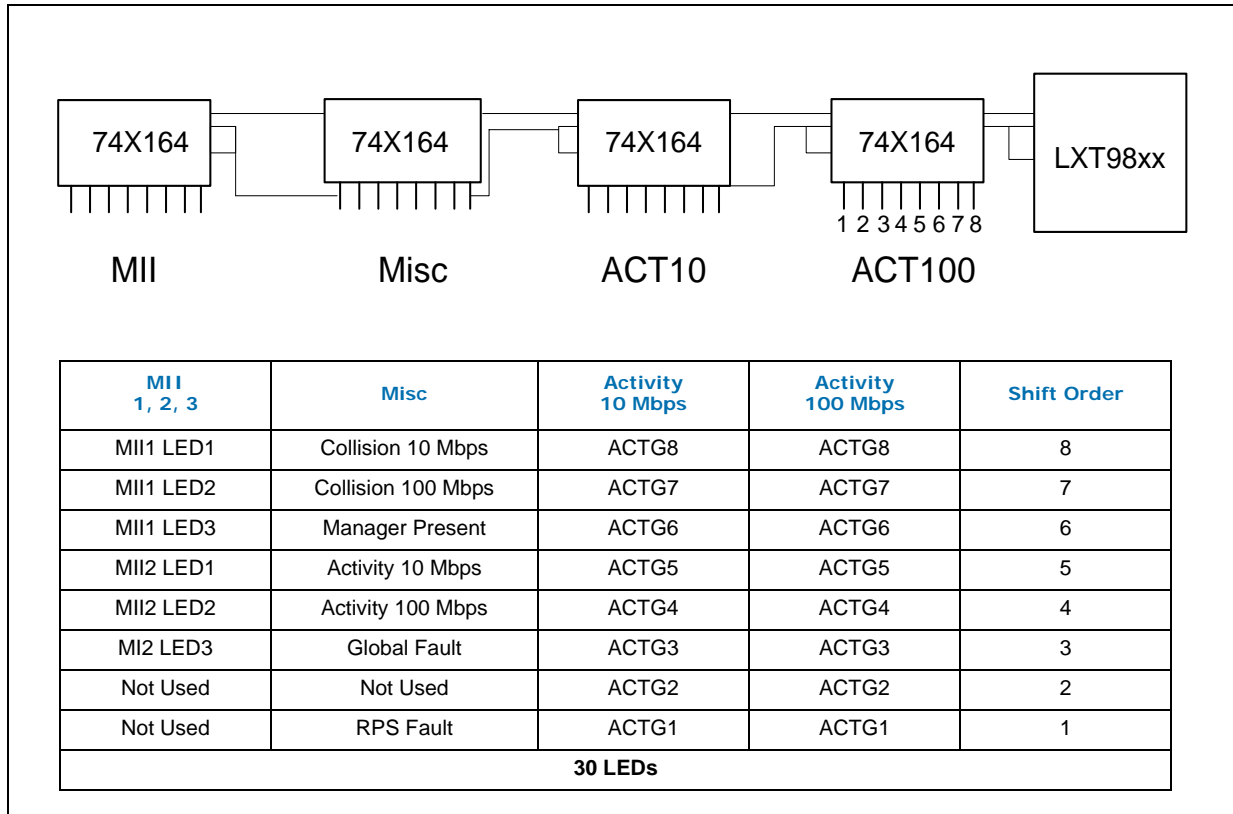

2.7.4.2 Serial LED Signals

The LED serial interface bus consists of three LXT98x0 Repeater outputs: clock (LEDCLK), parallel load clock (LEDLAT), and output data (LEDDAT). Refer to [Table 8 on page 25](#) for signal descriptions and to [Figure 28 on page 69](#) for an illustration of the LED serial interface circuit. Refer to [Figure 7](#) and [Table 12](#) for details on the LED serial bit stream.

Figure 7 Serial LED Port Signaling

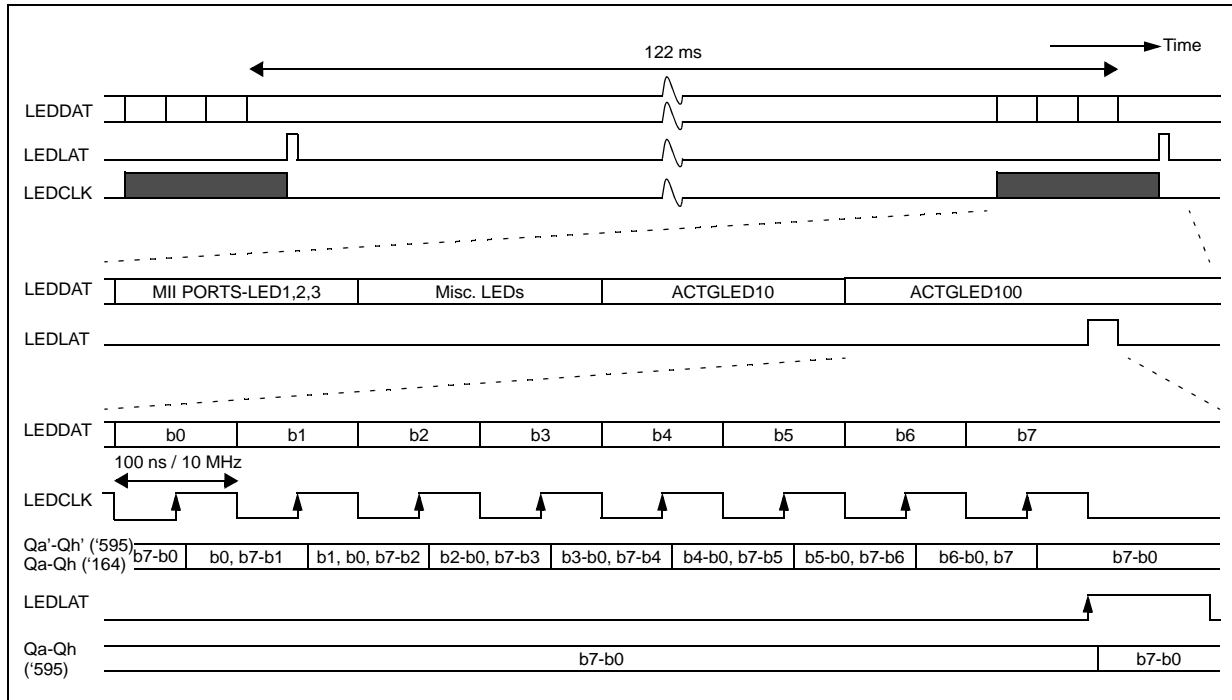

Table 12 Serial LED Port Bit Stream

Bit	MII Ports-LED1, 2, 3	Misc.	ACTGLED10	ACTGLED100
7	MII Port 1 - LED1	Collision - 10M ¹	ACTG8	ACTG8
6	MII Port 1 - LED2	Collision - 100M ¹	ACTG7	ACTG7
5	MII Port 1 - LED3	Manager Present	ACTG6	ACTG6
4	MII Port 2 - LED1	Activity - 10M ¹	ACTG5	ACTG5
3	MII Port 2 - LED2	Activity - 100M ¹	ACTG4	ACTG4
2	MII Port 2 - LED3	Global Fault	ACTG3	ACTG3
1	Not Used	Not Used	ACTG2	ACTG2
0	Not Used	RPS Fault	ACTG1	ACTG1

1. These LEDs are multiplexed with Configuration Inputs.

2.7.4.3 Activity Graph LEDs

The ACTGLED10 and ACTGLED100 LEDs are for activity bar graphing. The activity information is integrated and updated over a period of 328.125 ms, which has the effect of smoothing out the activity. LEDs are provided for both the 10 Mbps and 100 Mbps segments.

There are two display modes for the activity bar graphs, Base-2 and Base-10. The modes are selected via the LEDABGSEL pin. Refer to [Table 13](#) for details. Each step LED on the bar graph is lit when the percent activity value associated with that step is met or exceeded.

Table 13 ACTGLED Display Modes

LED	LEDABGSEL = 0 (Base-10)	LEDABGSEL = 1 (Base-2)
ACTG 8	60+% Activity	80+% Activity
ACTG 7	50% Activity	64% Activity
ACTG 6	40% Activity	32% Activity
ACTG 5	30% Activity	16% Activity
ACTG 4	20% Activity	8% Activity
ACTG 3	10% Activity	4% Activity
ACTG 2	5% Activity	2% Activity
ACTG 1	1% Activity	1% Activity

2.7.5 Direct Drive LEDs

The LXT98x0 Repeater provides three direct drive LEDs for each port (PORT n _LED1:3), excluding the two MII ports. Four additional segment LEDs indicate Collision 10/100 and Activity 10/100. The per-port LEDs are updated simultaneously to illustrate clear, non-overlapping status.

The following device pins are multifunctional (input = configuration; output = LED driver): COL10_LED (185), COL100_LED (186), ACT10_LED (183), ACT100_LED (184), and, PORT8_LED2 (175). The LED drive level is determined by the particular input configuration function of the respective pin. Collision and Activity indications for both 10 Mbps and 100 Mbps segments are available in both serial and direct drive.

Direct Drive LED outputs can be overridden by software control. Two bits per port configure the LEDs to one of four states:

- LED Off
- LED On
- LED Fast Blink
- LED Under Hardware Control

2.7.6 LED Modes

The four available LED modes are described in [Table 15 - Table 18](#). Hardware pins provide global LED mode control. Refer to [Table 8 on page 25](#) for pin assignments and signal descriptions. Software can configure each port individually to operate in any mode. Refer to [Section 5.8.4, Port LED Control Register, on page 113](#). [Section 5.8.3, LED Global Control Register, on page 113](#) outlines how the Global LEDs are similarly controlled. [Table 14](#) defines terms used to describe LED operation.

Table 14 LED Terms

Term	Definition
Port_Enabled	True if port is enabled. (see Table 60 on page 104).
Link_Enabled	True if link detection is enabled (see Table 58 on page 103 .)
Link_OK	True if link is enabled and link is detected or if link detection is disabled. Always true for MII port.
Port_Partitioned	True if port has been auto partitioned (10Mb mode). True if port has been auto partitioned or isolated (100Mb mode).
Port_Is_TP	True if port is a twisted-pair port.
RPS_Present	True if redundant power supply is switched in.
RPS_Fault	True if redundant power supply has a fault.
Port_Ctl_HW	True if configuration bits are set to hardware control.
Port_Ctl_Off	True if configuration bits are set to turn off the LED.
Port_Ctl_On	True if configuration bits are set to turn on the LED solid.
Port_Ctl_Fast	True if configuration bits are set to fast blink the LED.
Rcv_Activity	True if twisted-pair port on this device is receiving a packet.
Mgr_Present	True if MGR_PRES signal is active.

2.7.6.1 LED Mode 1

Mode 1 operations are described in [Table 15](#).

Table 15 LED Mode 1 Indications

LED	Operating Mode		Hardware Control ¹			Software Control
			On	Blink	Off	
PORT _n LED1	10 Mbps operation		Link_OK, not Port_Partitioned	N/A	Any other state	Off via port LED Control Register
	100 Mbps operation					
PORT _n LED2	10 Mbps operation		Link_OK, Port_Partitioned			
	100 Mbps operation					
PORT _n LED3	Auto-negotiate enabled	AUTOBLINK active	100 Mbps Link_OK	Not Link_OK (Fast Blink)	10 Mbps Link_OK	
		AUTOBLINK inactive		N/A		
	Auto-negotiate disabled		100 Mbps mode selected Link_Enabled	N/A	10 Mbps mode selected Link_Enabled	
Collision and Activity LEDs	Any		<p>The collision and activity LEDs are on a Per Segment basis. Pulse stretchers are used to extend the on-time for the LEDs. For every on-cycle of the stretched LEDs, an off-cycle, with the same period as the on-cycle, always follows.</p> <p>The collision LEDs turn on for approximately 120 μs when the LXT98x0 Repeater detects a collision on the segments. During the time that the LED is on, any additional collisions are ignored by the collision LED logic.</p> <p>The activity LEDs turn on for approximately 4 ms when the LXT98x0 Repeater detects any activity on the segments. During the time that the LED is on any additional activity is ignored by the activity LED logic.</p>			
Global Fault	Any		Any Port_Partitioned or RPS_Fault and RPS_Present	N/A	Any other state	
RPS Fault	Any		RPS_Present, RPS_Fault			
Manager Present	Any		Mgr_Present	N/A	Not Mgr_Present	N/A
1. Refer to Table 13: LED Terms, which defines all key terms used in this section.						

2.7.6.2 LED Mode 2

Mode 2 operations are described in [Table 16](#).

Table 16 LED Mode 2 Indications

LED	Operating Mode		Hardware Control ¹			Software Control
			On	Blink	Off	
PORT _n LED1	Any		10 Mbps: Port_Enabled, Link_OK, not Port_Partitioned 100 Mbps: Port_Enabled, Link_OK, not Port_Partitioned	10 Mbps: Port_Enabled, Link_OK, and Port_Partitioned (slow blink) 100 Mbps: Port_Enabled, Port_Partitioned (Slow Blink)	Any other state	On, Off or Fast Blink via Port LED Control Register
PORT _n LED2			Rcv_Activity (20 ms pulse) ²	N/A	Any other state	N/A
PORT _n LED3	Auto-negotiate enabled	AUTOBLINK active	100 Mbps Link_OK	No Link_OK (Fast Blink)	10 Mbps Link_OK	Off via Port LED Control Register
		AUTOBLINK inactive		N/A		
	Auto-negotiate disabled		100 Mbps mode selected (Link_Enabled)			10 Mbps mode selected (Link_Enabled)
Collision and Activity LEDs	Any		<p>The collision and activity LEDs are on a Per Segment basis. Pulse stretchers are used to extend the on-time for the LEDs. For every on-cycle of the stretched LEDs, an off-cycle, with the same period as the on-cycle, always follows.</p> <p>The collision LEDs turn on for approximately 120 ms when the LXT98x0 Repeater detects a collision on the segments. During the time that the LED is on, any additional collisions are ignored by the collision LED logic.</p> <p>The activity LEDs turn on for approximately 4 ms when the LXT98x0 Repeater detects any activity on the segments. During the time that the LED is on, any additional activity is ignored by the activity LED logic.</p>			N/A
Manager Present			N/A	N/A	Always Off	N/A
RPS			RPS_Present, no RPS_Fault	RPS_Present, RPS_Fault (Slow Blink)	Not RPS_Present	N/A
Global FAULT	Any		N/A	Any Port_Partitioned, any Port Isolated or RPS_Fault and RPS_Present (Slow Blink)	Any other state	On, off, or slow blink via global LED Control Register

1. Refer to [Table 14](#): LED Terms, which defines all key terms used in this section.
 2. Receive activity is stretched to a 20 ms wide pulse. For every on-cycle of the stretched LEDs, an off-cycle, with the same period as the on-cycle, always follows.

2.7.6.3 LED Mode 3

Mode 3 operations are described in [Table 17](#).

Table 17 LED Mode 3 Indications

LED	Operating Mode		Hardware Control			Software Control
			On	Blink	Off	
PORT _n LED1	10 Mbps operation		Link_OK, not Port_Partitioned	N/A	Any other state	Off via port LED Control Register
	100 Mbps operation					
PORT _n LED2	10 Mbps or 100 Mbps ops		Rcv_Activity (20 ms pulse) ²	N/A	Any other state	N/A
PORT _n LED3	Auto-negotiate enabled	AUTOBLINK active	100 Mbps Link_OK	No Link_OK (Fast Blink)	10 Mbps Link_OK	Off via port LED Control Register
		AUTOBLINK inactive	100 Mbps mode selected (Link_Enabled)	N/A	10 Mbps mode selected (Link_Enabled)	
	Auto-negotiate disabled					
Collision and Activity LEDs	Any		<p>The collision and activity LEDs are on a Per Segment basis. Pulse stretchers are used to extend the on-time for the LEDs. For every on-cycle of the stretched LEDs, an off-cycle, with the same period as the on-cycle, always follows.</p> <p>The collision LEDs turn on for approximately 120 ms when the LXT98x0 Repeater detects a collision on the segments. During the time that the LED is on, any additional collisions is ignored by the collision LED logic.</p> <p>The activity LEDs turn on for approximately 4 ms when the LXT98x0 Repeater detects any activity on the segments. During the time that the LED is on, any additional activity is ignored by the activity LED logic.</p>			N/A
Global Fault	Any		Any Port_Partitioned or RPS_Fault and RPS_Present	N/A	Any other state	Off via global LED Control Register
RPS Fault			RPS_Present, RPS_Fault			N/A
Manager Present			Mgr_Present	N/A	Not Mgr_Present	N/A
<p>1. Refer to Table 14: LED Terms, which defines all key terms used in this section.</p> <p>2. Receive activity is stretched to a 20 ms wide pulse. For every on-cycle of the stretched LEDs, an off-cycle, with the same period as the on-cycle, always follows.</p>						

2.7.6.4 LED Mode 4

Mode 4 operations are described in [Table 18](#).

Table 18 LED Mode 4 Indications

LED	Operating Mode		Hardware Control ¹			Software Control	
			On	Blink	Off		
PORT _n LED1	10 Mbps operation		Link_OK, not Port_Partitioned	20 ms Blink indicates Rcv_Activity ²	Any other state	Off via port LED Control Register	
	100 Mbps operation				Any other state		
PORT _n LED2	10 Mbps operation		Link_OK, Port_Partitioned	N/A	Any other state		
	100 Mbps operation						
PORT _n LED3	Auto-neg enabled	AUTOBLINK active	100 Mbps Link_OK	No Link_OK (Fast Blink)	10 Mbps Link_OK		
		AUTOBLINK inactive			10 Mbps Link_Enabled		
	Auto-neg disabled		100 Mbps Mode selected (Link_Enabled)	N/A	10 Mbps Link_Enabled		
Collision and Activity LEDs	Any		<p>The collision and activity LEDs are on a Per Segment basis. Pulse stretchers are used to extend the on-time for the LEDs. For every on-cycle of the stretched LEDs, an off-cycle, with the same period as the on-cycle, always follows.</p> <p>The collision LEDs turn on for approximately 120 ms when the LXT98x0 Repeater detects a collision on the segments. During the time that the LED is on, any additional collisions are ignored by the collision LED logic.</p> <p>The activity LEDs turns on for approximately 4 ms when the LXT98x0 Repeater detects any activity on the segments. During the time that the LED is on, any additional activity is ignored by the activity LED logic.</p>				N/A
Global Fault	Any		Any port partitioned or RPS_Fault and RPS_Present	N/A	Any other state		Off via global LED Control Register
RPS Fault			RPS_Fault and RPS_Present				N/A
Manager Present			Mgr_Present	N/A	Not Mgr_Present	N/A	

1. Refer to [Table 14](#): LED Terms, which defines all key terms used in this section.
 2. Receive activity is stretched to a 20 ms wide pulse. For every on-cycle of the stretched LEDs, an off-cycle, with the same period as the on-cycle, always follows.

2.8 IRB Operation

The Inter-Repeater Backplane (IRB) allows multiple devices to operate as a single logical repeater, exchanging data and collision status information. Each segment on the LXT98x0 Repeater has its own complete, independent IRB. The backplanes use a combination of digital and analog signals as shown in [Figure 9 on page 48](#).

2.8.1 IRB Signal Types

IRB signals can be characterized by the following connection types (For Stacking and Cascading connections, see [Table 19 on page 48](#)):

- **Local**—connected between devices on the same board
- **Stack**—connected between boards
- **Full**—connected between devices in the same board *and* between boards.

2.8.2 IRB Isolation

The ISOLATE outputs (IR10ISO and IR100ISO) are provided to control the enable pins of external bidirectional transceivers. In stacking applications, they can be used to isolate one board from the rest of the stack. Only one device can control these signals. The output states of these pins are controlled by the Isolate bits in the Repeater Configuration Register.

2.8.3 10 Mbps-Only Operation

2.8.3.1 MAC IRB Access

The MACACTIVE pin allows an external MAC or other digital ASIC to interface directly to the [10 Mbps IRB](#). When the MACACTIVE pin is asserted, the LXT98x0 Repeater drives the IR10CFS and IR10CFSBP signals on behalf of the external device, allowing it to participate in collision detection functions.

2.8.3.2 Management Master Chain Arbitration

This daisy chain is provided for correct statistics gathering in 10 Mbps cascaded configurations. In stacked applications, this daisy chain must be maintained through cascades. In stand-alone applications, or for the first device in a chain, the MMSTRIN input must be pulled Low for the management counters to work correctly.

2.8.4 LXT98x/91x/98x0 Compatibility

The LXT98x0 Repeater devices feature low-power 3.3 V design. The LXT98x and LXT91x devices operate at 5 V and are incompatible with the LXT98x0 Repeater devices in cascades. The LXT98x0 Repeater devices, however, are *backwards stackable* with LXT98x and LXT91x repeaters.

Note: Refer to [Section 3.4, Inter-Repeater Backplane Compatibility](#), on page 69.

Figure 8 100 Mbps IRB Connection

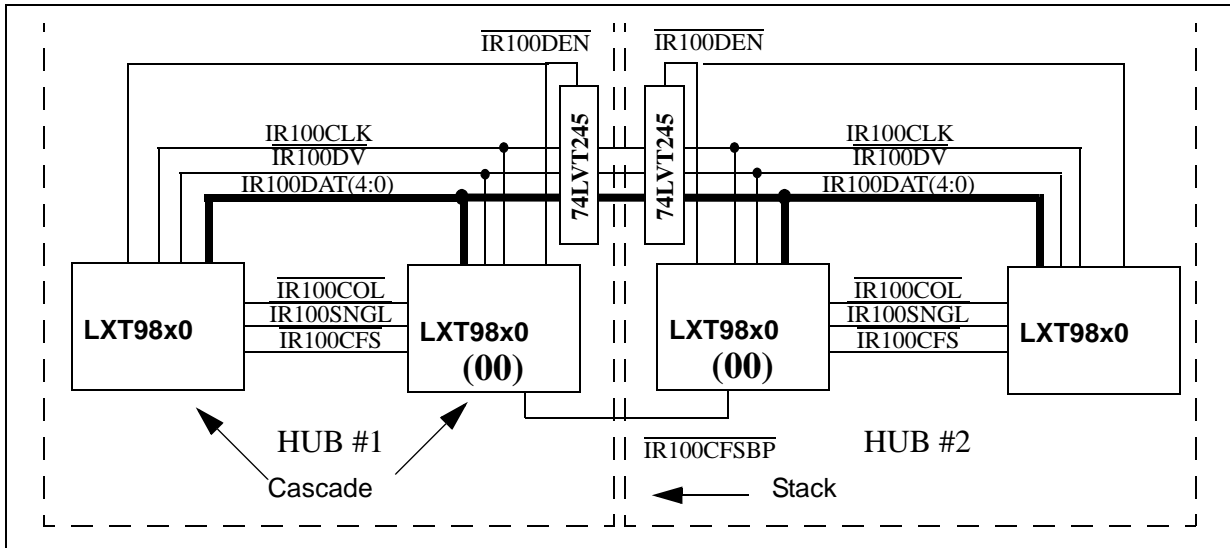

Figure 9 IRB Block Diagram

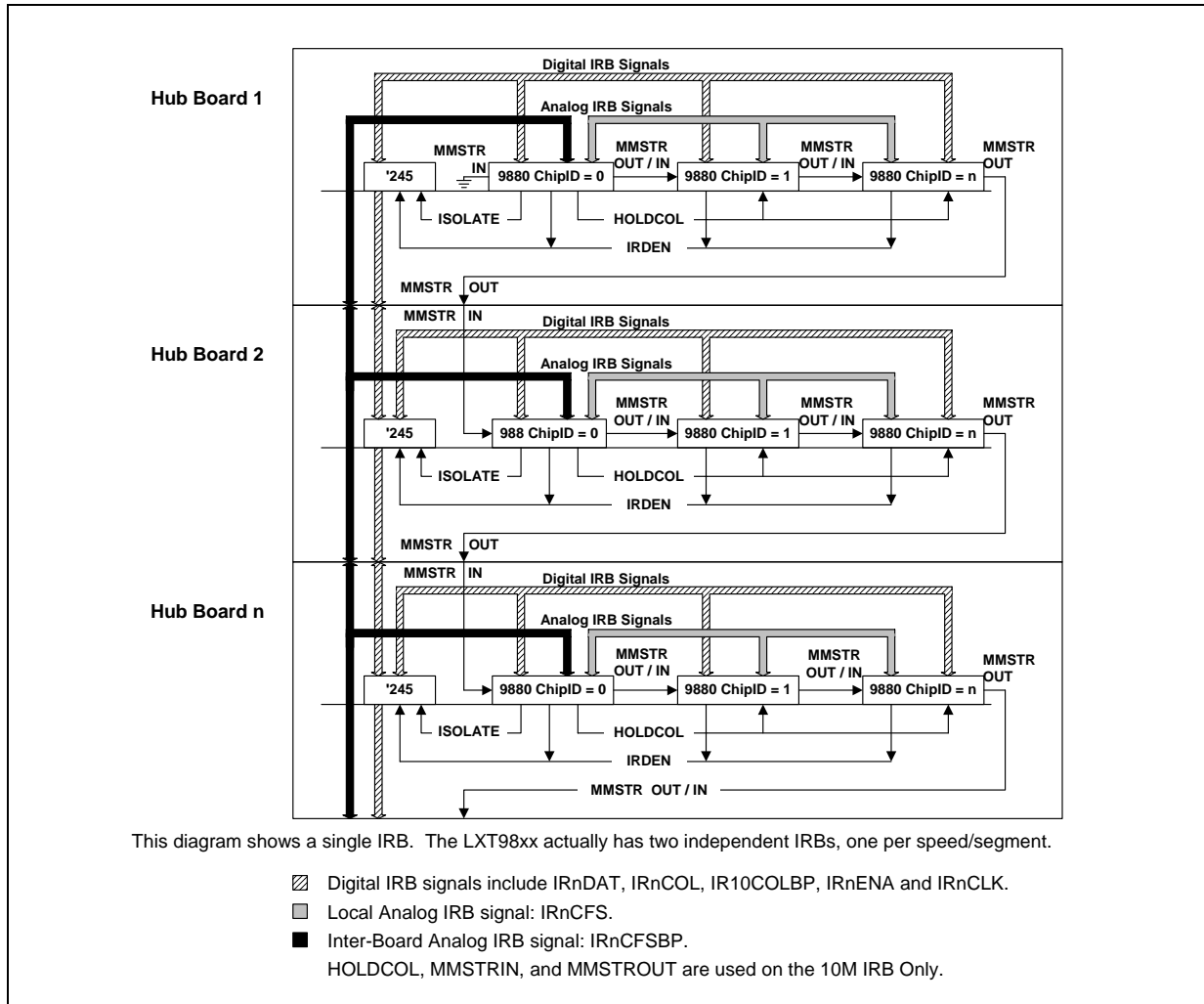

Table 19 Cascading and Stacking Connections

Signal Type	Connections Between Devices (Cascading)	Connections Between Boards (Stacking)
Local	Connect all.	<i>Do not connect.</i>
Stack	For devices with ChipID ≠ 00, pull-up at each device and <i>do not interconnect.</i>	Connect devices with ChipID = 00 between boards. Use one pull-up resistor per stack.
Full	Connect all.	Connect using buffers.
Special (xxISO)	For devices with ChipID ≠ 00, leave open. For device with ChipID = 00, connect to buffer enable.	<i>Do not connect.</i>

Table 20 IRB Signal Details

Name	Pad Type	Buffer	Pull-up	Connection Type
100 Mbps IRB Signals				
IR100DAT<4:0>	Digital	Yes	No	Full
IR100CLK	Digital	Yes	1K	Full
IR100DV	Digital, Open Drain	Yes	300Ω	Full
IR100CFS	Analog	No	215 Ω, 1%	Local
IR100CFSBP	Analog	No	91 Ω, 1%	Stack
IR100COL	Digital	No	No	Local
IR100SNGL	Digital	No	No	Local
IR100DEN	Digital, Open Drain	N/A ¹	330 Ω	Local
IR100ISO	Digital	N/A ¹	No	Special
10 Mbps IRB Signals				
IR10DAT	Digital, Open Drain	Yes	330 Ω	Full
IR10CLK	Digital	Yes	No	Full
IR10ENA	Digital, Open Drain	Yes	330 Ω	Full
IR10CFS	Analog	No	215 Ω, 1%	Local
IR10CFSBP	Analog	No	330 Ω, 1%	Stack
IR10COL	Digital	No	330 Ω, 1%	Local
IR10COLBP	Digital	No	330 Ω, 1%	Stack
IR10DEN	Digital, Open Drain	N/A ¹	330 Ω	Local
IR10ISO	Digital	N/A ¹	No	Special
1. Isolate and Driver Enable signals are provided to control an external bidirectional transceiver.				

2.9 MII Port Operation

The LXT98x0 Repeater MII ports allow direct connection with a MAC. The MII ports can operate at either 10 Mbps or 100 Mbps. Speed control is provided via MII_n_SPD. For 100 Mbps operation, set MII_n_SPD = 1. For 10 Mbps operation, set MII_n_SPD = 0.

The LXT98x0 Repeater maintains the same statistics for the MIIs as it does for the 10/100 ports (except for isolate, partition, and illegal symbols). The LXT98x0 Repeater does *not* provide MDIO/MDC capability, as this is provided via the Serial Management Interface (SMI).

2.9.1 Preamble Handling

When operating at 100 Mbps, the LXT98x0 Repeater passes the full 56 bits of preamble through before sending the SFD. When operating at 10 Mbps, the LXT98x0 Repeater sends data across the MII starting with the 8-bit SFD (no preamble bits).

Note: MII Ports do not count partition, isolation, or symbol errors.

Figure 10 LXT9880 Repeater MII Operation

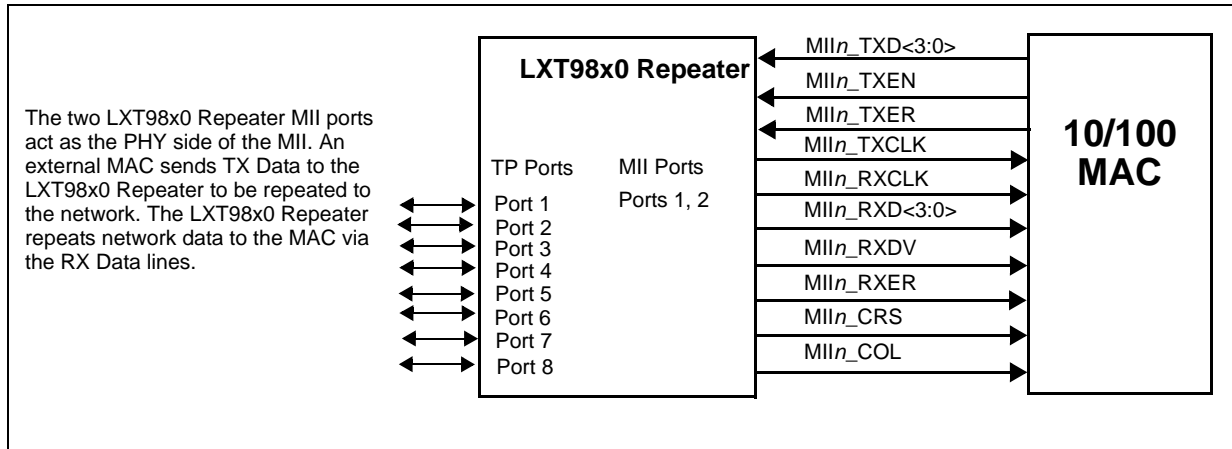

2.10 Serial Management I/F

The high-speed Serial Management Interface (SMI) provides access to repeater MIB variables, RMON Statistics attributes and status and control information. A network manager accesses the interface through a simple serial communications controller such as an 8530 SCC. The SMI allows multiple LXT98x0 Repeater devices to be managed from one common bus.

2.10.1 SMI Signals

The interface consists of a data input line (SRX), data output line (STX), and a clock (SERCLK). The interface operates on a simple command response model, with the network manager as the master and the LXT98x0 Repeater devices as slaves. [Figure 11](#) is a simplified view of typical serial management interface architecture. Refer to [Figure 23](#) on page 66 for circuit details.

Note: Refer to Application Note 64, *High-Speed Serial Management Interface*, for additional information.

Figure 11 Typical SMI Bus Architecture

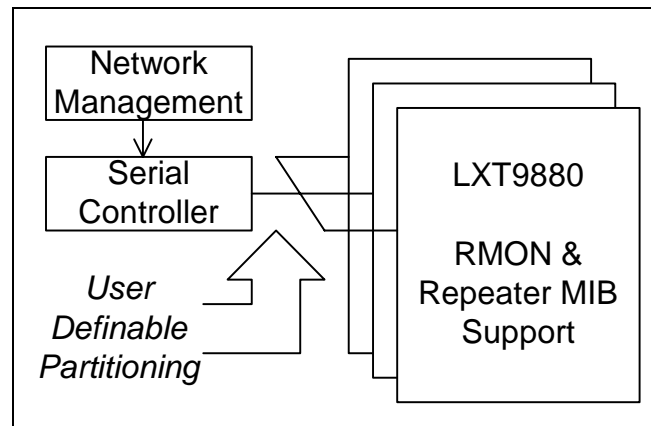

2.10.1.1 Serial Clock

SERCLK is a bidirectional pin; direction control is provided by the RECONFIG input. If RECONFIG is High, the LXT98x0 Repeater drives SERCLK at 625 kHz. If RECONFIG is Low, SERCLK is an input, between 0 and 2 MHz. The clock can be stopped after each operation, as long as an idle (at least 12 ones in a row) is transmitted first.

2.10.1.2 Serial Data I/O

The serial data pins, SRX and STX, should be “logically” tied together using open-collector buffers. See [Figure 23 on page 66](#). The SRX input is compared with the STX output. If a mismatch occurs, STX goes to a high impedance. STX is driven on the falling edge of SERCLK. SRX is sampled on the rising edge.

2.10.2 Read and Write Operations

Data can be read or written in blocks. The LXT98x0 Repeater can read the full length field of consecutive counters with a single access. Block writes are limited to 2 long words.

Normally the network manager directs read and write operations to a specific LXT98x0 Repeater device using a two-part address consisting of HubID and Chip Address.

Note: In the Header Field, the Chip Address is defined by three bits. The Most Significant Bit (MSB) = 0; the value of the other two bits is set by pins.

The LXT98x0 Repeater responds to an operation within 12 serial controller bit times. In the case of an error during a transfer, the LXT98x0 Repeater does not implement the requested command.

2.10.2.1 SMI Collision Handling

Upon colliding with another packet, the LXT98x0 Repeater ceases transmission, based on the bit pattern of the colliding packets as shown in [Figure 12](#). In the case of a collision, the driver who is sourcing a 0 wins. The LXT98x0 Repeater does not retry a response, unless it was an address arbitration packet. In addition, if an address arbitration packet jumps in during a request/response sequence, before the addressed LXT98x0 Repeater has responded, the addressed LXT98x0 Repeater aborts the requested operation.

Note: The minimum time between packets must be at least 12 bit times with the data set to all ones.

2.10.2.2 SMI Address Match Indication

The LXT98x0 Repeater SER_MATCH pin (see [Figure 13](#)) indicates detection of a serial command matching the device Hub ID. Broadcast commands also trigger the SER_MATCH output. Note that the initial HubID upon power-up or reset is the Broadcast (all ones) address.

Figure 12 SMI Collision Handling

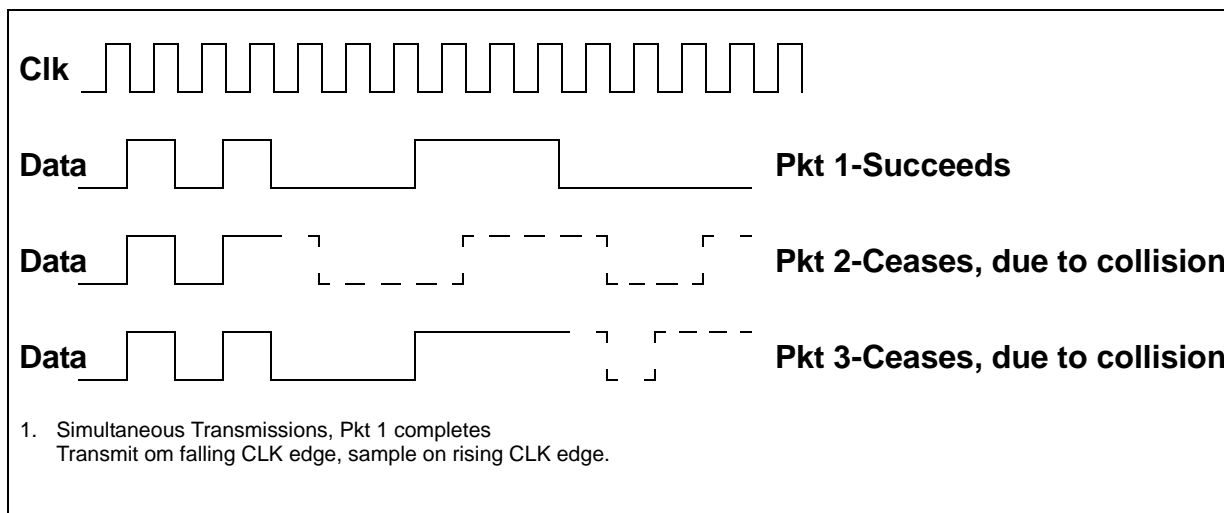
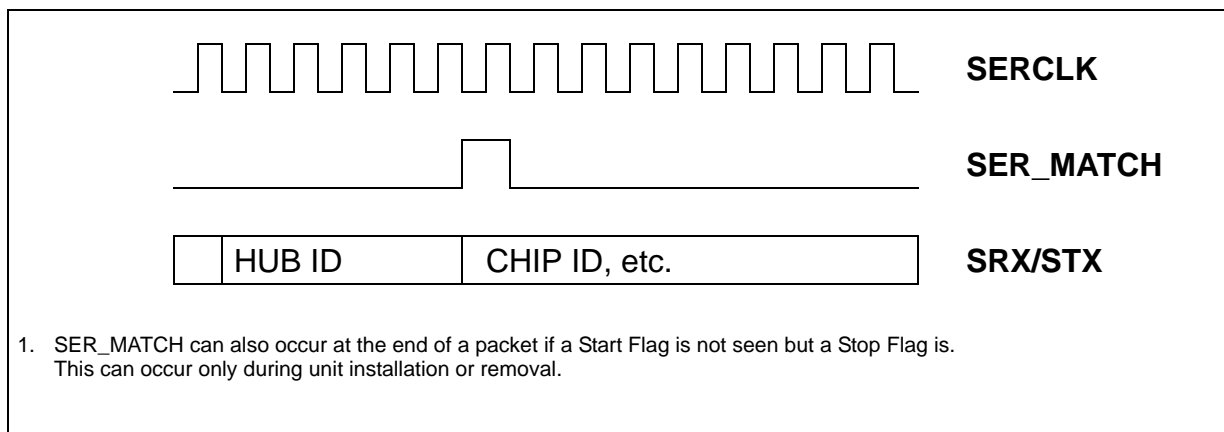

Figure 13 SMI Address Match Indication



2.10.2.3 SMI Frame Format

The SMI uses a simple frame format, shown in [Figure 14](#). [Table 21](#) describes the individual fields. [Table 22](#) shows how the bits for the header field are stored in memory, assuming that they are transmitted LSB to MSB, low address to high address. [Table 23](#) lists the command set and [Table 24](#) provides a variety of typical packets.

All frames begin and end with a simple flag consisting of “01111110”. Multiple flags cause the LXT98x0 Repeater to ignore the packet. All fields are transmitted LSB first. Zero-bit stuffing is required if more than five 1s in a row appear in the header, data or CRC fields. In addition, all operations directed to the device must be followed by an idle (at least 12 ones in a row), and the first operation must be preceded with an idle.

Note: The LXT98x0 Repeater uses the CCITT method of CRC ($X^{16} + X^{12} + X^5 + 1$).

Table 21 SMI Message Fields

Message	Description
Start or Stop Flag	"01111110". Protocol requires zero insertion after any five consecutive "1"s in the data stream.
Hub ID	Identifies board or sub-system. Assigned by one of two arbitration mechanisms at power-up.
Chip ID	Identifies one of eight devices on a system. Assigned by 2 external pins on each device. The Most Significant Bit (MSB) = 0; the value of the other two bits is set by pins.
Command	Identifies the particular operation being performed (see Table 23)
Length	Specifies number of registers to be transferred (1 to 127). Maximum is 2 per write, 127 per read.
Address	Specifies address of register or register block to be transferred.

Figure 14 Serial Management Frame Format

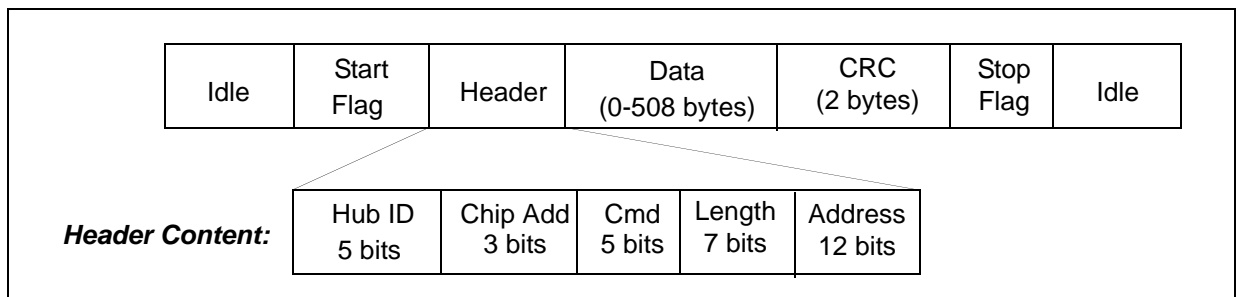

Table 22 SMI Header Storage

	MSB							LSB
Increasing Address ↑	Addr 11	Addr 10	Addr 9	Addr 8	Addr 7	Addr 6	Addr 5	Addr 4
	Addr 3	Addr 2	Addr 1	Addr 0	Length 6	Length 5	Length 4	Length 3
	Length 2	Length 1	Length 0	CMD 4	Cmd 3	Cmd 2	Cmd 1	Cmd 0
	Chip Address Bit 2 (set to 0)	Chip Address Bit 1	Chip Address Bit 0	HubID 4	HubID 3	HubID 2	HubID 1	HubID 0

Table 23 SMI Command Set

Command Value	Name	Usage	Normally Sent By	Description
18 (Hex)	Write	Normal Ops	Network Mgr	Used to set a register or group of registers. The minimum write size is 1 long word. The maximum block write is 2 long words. This size was chosen so that software may write an entire Ethernet address in one serial packet.
04 (Hex)	Read	Normal Ops	Network Mgr	Used to get complete sets of counter information for either a port or a segment. The minimum read size is 32 bits (one long word). The maximum block read is 127 long words. The acknowledge for this instruction is the actual returned data.
08 (Hex)	Request ID	Arbitration	LXT98x0 Repeater	For Hub ID (Arb Method 1): The LXT98x0 Repeater repeats this command periodically until it is assigned a Hub ID. Once assigned, the command is discontinued.
00 (Hex)	ConfigChg	Arbitration	LXT98x0 Repeater	Notifies system of configuration change (hot swap). Requests new arbitration phase.
10 (Hex)	Re-arbitrate	Arbitration	Network Mgr	Re-starts arbitration. Assigns all new addresses.
14 (Hex)	Assign HubID	Chain Arbitration	Network Mgr	Assigns Hub ID to device with ARBIN = 0 and ARBOUT = 1
0C (Hex)	Set Arbout to 1	Chain Arbitration	Network Mgr	Used to determine stacking order or assign address. Commands specific device to set ARBOUT= 1. This command can apply to either a single LXT98x0 Repeater (via direct addressing), or every LXT98x0 Repeater through the use of the broadcast address.
1C (Hex)	Set Arbout to 0	Chain Arbitration	Network Mgr	Used to determine stacking order or assign address. Commands specific device to set ARBOUT = 0. This command can apply to either a single LXT98x0 Repeater (via direct addressing), or every LXT98x0 Repeater through the use of the broadcast address.
02 (Hex)	DevID	Config	Network Mgr	Asks device to send contents of device revision register. This command applies to only a single LXT98x0 Repeater at a time. When given, the command causes the chip to retrieve its type and revision code data (hard coded for a given device) and provide it to the serial controller for transmission back to the requesting manager. The acknowledge for this type of packet is the actual returned data. This command can also be used for 'ping' operations.

Table 24 Typical Serial Management Packets

Message	Contents of Fields in Serial Management Packet					
	Hub ID	Chip Address ⁵	Command	Length	Address	Data
Write ^{1, 2}	User defined	User defined	18 Hex	01 or 02 Hex	User defined	User defined
Read Request ^{1, 3, 4}	User defined	User defined	04 Hex	01 to 7F Hex	User defined	Null
Read Response ³	00000	000	04 Hex	01 to 7F Hex	User defined	Data values
Assign Hub ID (Arb Method 1)	11111	011	18 Hex	02 Hex	188 Hex	Formatted per Table 88 on page 117 and Table 89 on page 118
Assign Hub ID (Arb Method 2)	11111	011	14 Hex	01 Hex	000 Hex	Hub ID (LSB) and 27 0s
Set About to 0	User defined	User defined	1C Hex	00 Hex	000 Hex	Null
Set About to 1	User defined	User defined	0C Hex	00 Hex	000 Hex	Null
Arb Request	00000	000	08 Hex	02 Hex	190 Hex	PROM ID
Resend Arbitration	11111	011	10 Hex	00 Hex	000 Hex	Null
Resend Arbitration Response	00000	000	08 Hex	02 Hex	190 Hex	PROM ID
Device type/Revision code	User defined	User defined	02 Hex	01 Hex	000 Hex	Null
Device/Revision Response	00000	000	02 Hex	01 Hex	13C Hex	Device type/revision

1. Other than checking that the top 3 bits of the address equals 000, the LXT98x0 Repeater does not check if the user writes or reads past the highest location. There are no adverse effects for writing or reading locations above the specified range.
 2. If the user performs a write operation of length 1 or 2 and does not send a data field, the LXT98x0 Repeater writes junk into the specified registers. This constitutes an invalid command.
 3. If the user reads past the highest location of the LXT98x0 Repeater, all those locations reads back 0s.
 4. If a read operation is performed with a length of 0, the LXT98x0 Repeater does not respond.
 5. ChipID is defined by 3 bits, with the MSB = 0; value of the other two bits is set by pins.

2.10.3 Address Assignment Methods

Each device has a two part address, consisting of a HubID and a Chip Address (See [Figure 14 on page 53](#)). The Chip Address is assigned by the input pins CHIPID<1:0>. (The Most Significant Bit [MSB] = 0.)

The manager assigns the HubID. Each LXT98x0 Repeater on a particular board has the same HubID. The HubID is assigned through one of two arbitration mechanisms as shown in [Figure 15](#).

Figure 15 Address Arbitration Mechanisms

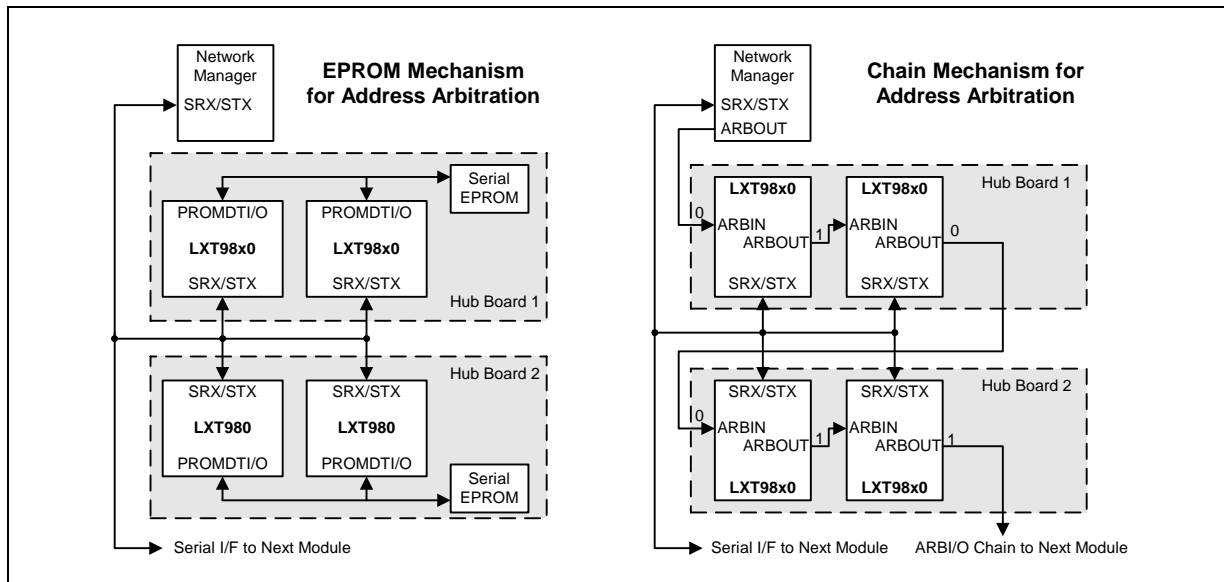

2.10.3.1 Chain Arbitration Mechanism

The chain method is the easiest and requires no serial PROM. The ARBSELECT pin on all devices must be set to 1. When constructing the stack, the designer creates a daisy chain by tying the ARBOUT pin of each LXT98x0 Repeater to the ARBIN pin of the following LXT98x0 Repeater. The manager is at the top of the stack and controls the ARBIN for the first LXT98x0 Repeater. The manager progressively assigns Hub IDs using the Assign Hub ID (Arb Method 2) and Set ARBOUT to ZERO commands. The manager initially sets its ARBOUT (first LXT98x0 Repeater's ARBIN) to zero. Since the Assign Hub ID (Arb Method 2) command only works on the LXT98x0 Repeater with ARBIN of 0 and an ARBOUT of 1, the first LXT98x0 Repeater can be assigned an address. After the first LXT98x0 Repeater has been assigned an address, it can uniquely be told to switch its ARBOUT to zero. This creates the (01) condition on the next LXT98x0 Repeater in the line. This LXT98x0 Repeater is then assigned an address and the process continues until all chips have been assigned a unique address.

Note: It is recommended that HubIDs match in any given hub.

The manager can verify that a hub is still present by performing DEVICE ID commands. If a change of configuration is detected, the manager can perform a broadcast write to return each hub's ARBOUT to 1, and then re-perform the address assignment process.

When using the chain arbitration method, set up the daisy chain so the device with ChipID = 00 is the first device in the board that the chain passes through. When assigning IDs, the '1st in Chain' bit in the device revision register (refer to Table 77 on page 113) can be used to determine when a new board has been encountered.

2.10.3.2 PROM Arbitration Mechanism

This mechanism requires one serial PROM with a unique 48-bit ID in each board. This ID can consist of serial number, date/week/year of manufacture, etc. The ARBSELECT pin must be set to 0. At power-up, the device with ChipID = 00 reads a 48-bit ID from the

PROM. All other devices on the board listen in and record the ID. The device with ChipID = 00 then transmits Arbitration Request messages on the SMI every 2-3 ms. The request messages from two boards may collide. If this happens, a resolution scheme ensures that only one message is transmitted.

The network manager must respond to each request with a message that includes the 48-bit ID and the HubID. All devices hear this message, but only those matching the 48-bit ID receive the HubID as their own. Once a HubID is assigned to a hub, that hub ceases requesting a HubID. This process continues until all hubs are assigned an ID. Should a hub power off and back on, the hub re-requests an ID, which the manager provides. An address arbitration packet is selected over normal requests.

2.10.3.3 Address Re-Arbitration

There are two mechanisms for address re-arbitration following a configuration change, such as a hot-swap of a board:

- Manual Re-arbitration. If the LXT98x0 Repeater detects a Low-to-High transition on RECONFIG, or if RECONFIG is High at power-up, it sends out a “Configuration Change” message (Start Flag with all 0s) on the bus. The network manager can use this message to detect that re-arbitration is required.
- Network Manager. The network manager can detect or re-start arbitration at any time by sending the “Re-arbitrate” command.

2.10.4 Interrupt Functions

The LXT98x0 Repeater provides a single open-collector pin for external interrupt signalling. Several different interrupt conditions may be reported. The Interrupt Status Register (see [Table 85](#)) identifies the specific interrupt condition. The Interrupt Mask Register (see [Table 86 on page 117](#)) allows specific interrupts to be masked. Interrupts may be cleared in two ways, depending on the status of bit 11 in the repeater configuration register.

2.11 Serial PROM Interface

The serial PROM interface allows the vendor to load in optional information unique to each board. Items such as serial number or manufacture date can be placed in the serial PROM which can also be used in the address arbitration process. Each board must contain a unique set of information. Additionally, only 1 serial PROM is required per board, they are not required per chip. The LXT98x0 Repeater reads in the first 48 bits (three 16-bit words) from the PROM and stores them in a register. This read occurs only on power-up. Only the LXT98x0 Repeater with a ChipID of 00 drives the serial PROM control lines; all other LXT98x0 Repeaters “listen” to the data and clock lines. The first bit into the LXT98x0 Repeater from this interface corresponds to bit 47. The serial PROM shifts out the most significant bit (15) of the word first (the PROM must be auto-incrementing).

Figure 16 Optional R/W Serial PROM Interface

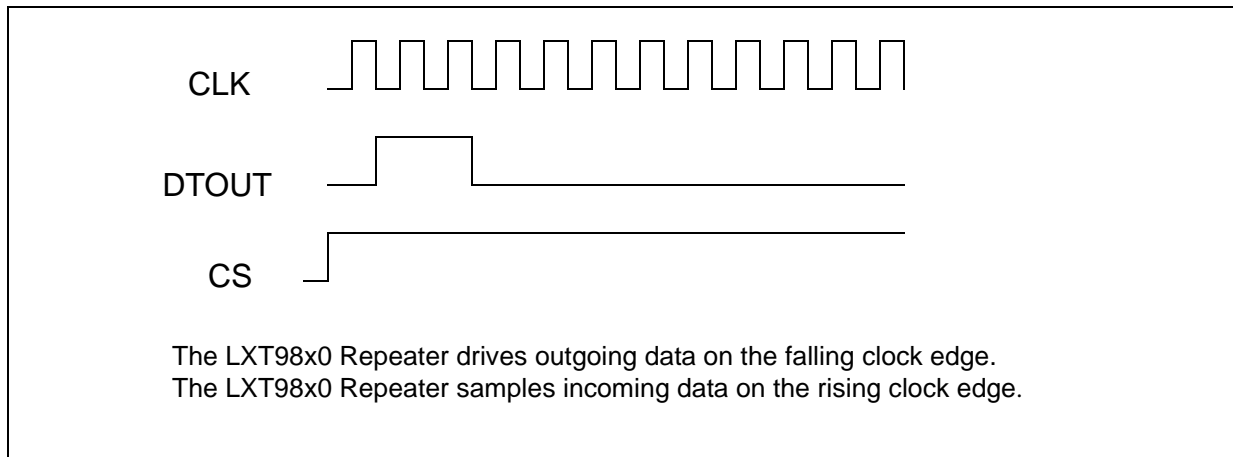

2.12 Serial Configuration Interface

The Serial Configuration Interface allows the user to load system-specific information (board type, plug-in cards, status, etc.) into the Repeater Configuration Register (see [Table 75 on page 111](#)). This register may be read remotely through the Serial Management Interface (SMI). The Serial Configuration Interface mode (Repeater Configuration Register bit 14 = 1) allows the collection of up to 8 bits of board data, compared to the CONFIG[1:0] 2-bit mode (bit 14 = 0). See [Table 75 on page 111](#).

For Serial Configuration Interface mode = 1, an external '165 device is used to perform a parallel-to-serial conversion of the board data (see [Figure 17](#)). These board data bits are shifted into the LXT98x0 Repeater each time the Repeater Serial Configuration register is read. CFG_DT is clocked into the LXT98x0 Repeater relative to the rising edge of CFG_CLK as shown in [Figure 18](#). Also note the register bit positions versus the '165 parallel input positions.

The CFG_CLK pin is shared with LED_CLK. For reading the Repeater Serial Configuration Register, the configuration bits are reloaded into the LXT98x0 Repeater. The shared functionality of the clock (configuration and serial LED), causes an unscheduled serial LED update. All 32 clock cycles occur with only the first 8 bits clocked into the Repeater Serial Configuration Register. See [Table 76 on page 112](#).

Figure 17 Serial Configuration Interface

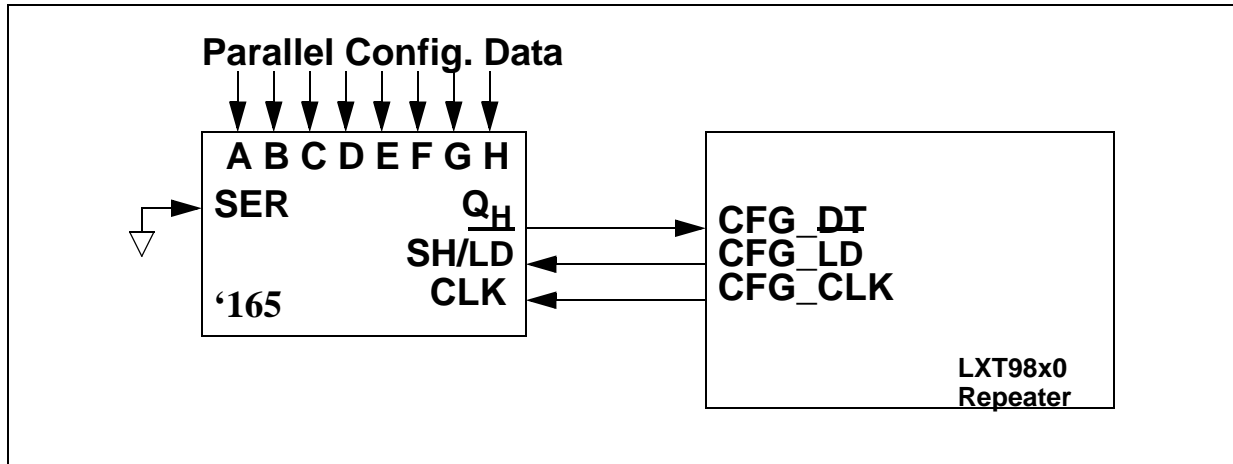
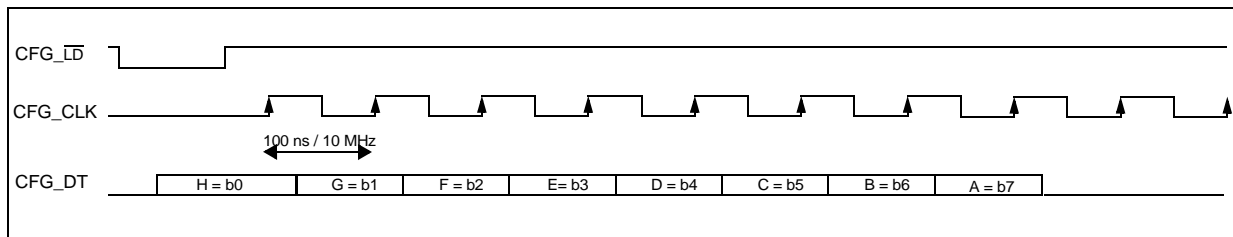

Figure 18 Serial Configuration Interface Signaling



3.0 Application Information

3.1 General Design Guidelines

Following generally accepted design practices is essential to minimize noise levels on power and ground planes. Up to 50 mV of noise is considered acceptable. 50 to 80 mV of noise is considered marginal. High-frequency switching noise can be reduced, and its effects can be eliminated, by following these simple guidelines throughout the design:

- Fill in unused areas of the signal planes with solid copper. Attach them with vias to a VCC or ground plane that is not located adjacent to the signal layer.
- Use ample bulk and decoupling capacitors throughout the design (a .01 μ F value is recommended for decoupling caps).
- Provide ample power and ground planes.
- Provide termination on all high-speed switching signals and clock lines.
- Provide impedance matching on long traces to prevent reflections.
- Route high-speed signals next to a continuous, unbroken ground plane.
- Filter and shield DC-DC converters, oscillators, etc.
- Do not route any digital signals between the LXT98x0 Repeater and the RJ-45 connectors at the edge of the board.
- Do not extend any circuit power and ground plane past the center of the magnetics or to the edge of the board. Use this area for chassis ground, or leave it void.

3.2 Typical Applications

Figure 19 and Figure 20 are simplified block diagrams showing typical applications. Figure 21 through Figure 26 show application circuitry details.

Figure 19 8-Port Managed 10/100 Stackable Repeater

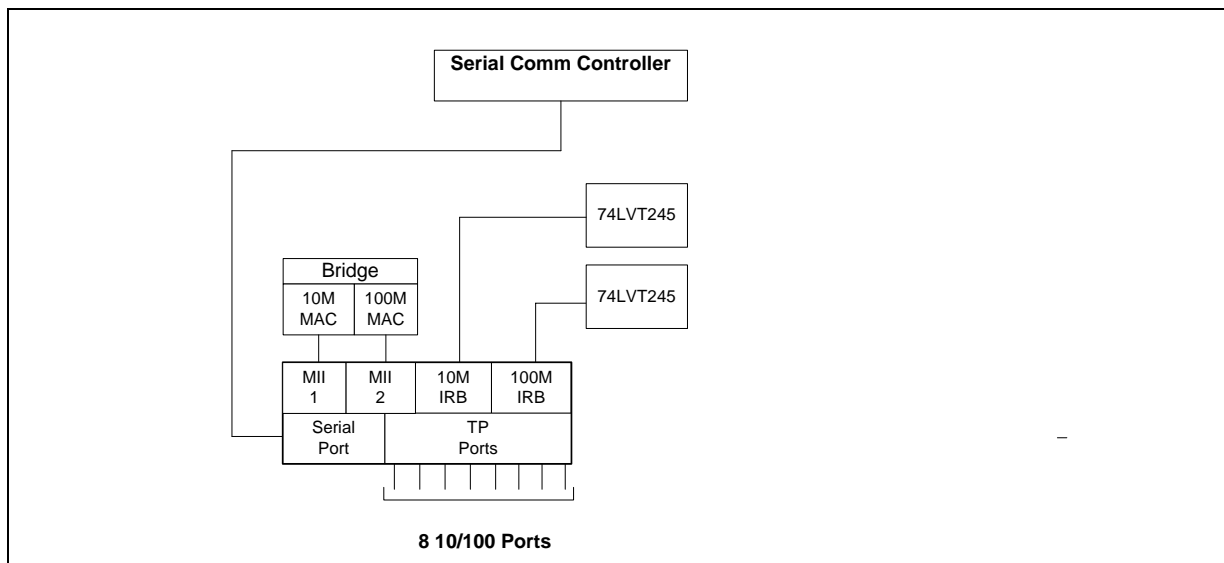
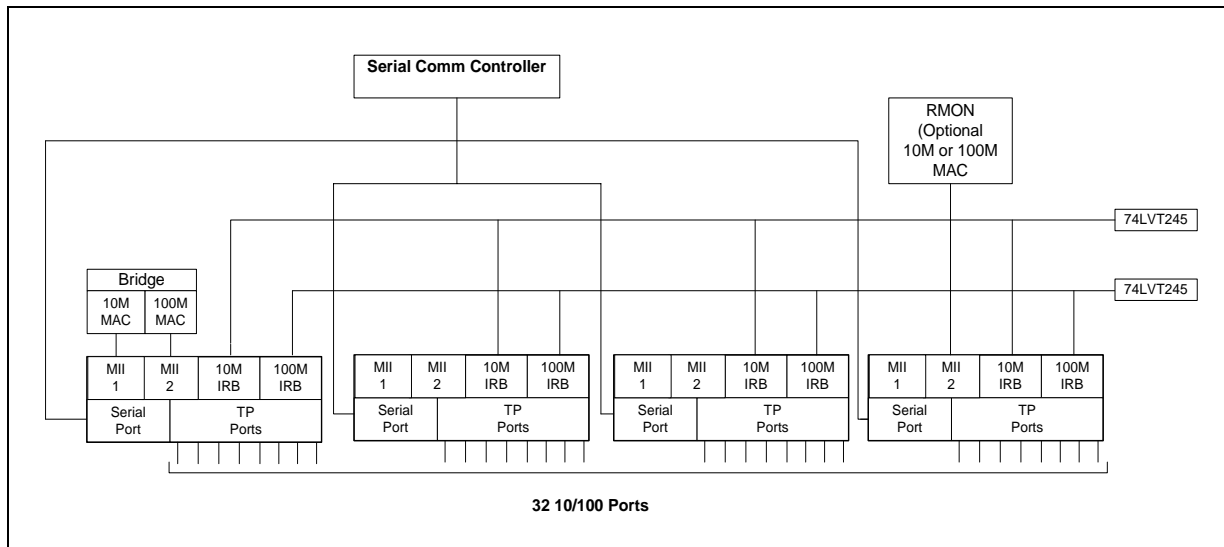

Figure 20 32-Port Managed 10/100 Repeater



3.3 Application Circuitry

3.3.1 Power and Ground

3.3.1.1 Supply Filtering

Power supply ripple and digital switching noise on the VCC plane causes EMI and degrades line performance. Predicting a design's performance is difficult, although certain factors greatly increase the risks:

- Poorly-regulated or over-burdened power supplies.
- Wide data busses (>32-bits) running at a high clock rate.
- DC-to-DC converters.

Many of these issues can be improved by following good general design guidelines. In addition, Cortina recommends filtering between the power supply and the analog VCC pins of the LXT98x0 Repeater. Filtering has two benefits. First, it keeps digital switching noise out of the analog circuitry inside the LXT98x0 Repeater, which helps line performance. Second, if the VCC planes are laid out correctly, it keeps digital switching noise away from external connectors, reducing EMI.

The VCC plane should be divided into two sections. The digital section supplies power to the digital VCC pins and to the external components. The analog section supplies power to VCCR and VCCT pins of the LXT98x0 Repeater. The break between the two planes should run under the device. In designs with more than one LXT98x0 Repeater, use a single continuous analog VCC plane to supply them all.

The digital and analog VCC planes should be joined at one or more points by ferrite beads. The beads should produce at least a 100 Ω impedance at 100 MHz. The beads should be placed so current flows evenly. The maximum current rating of the beads should be at least 150% of the current that is actually expected to flow through them. Each LXT98x0 Repeater draws a maximum of 1000mA from the analog supply so beads rated

at 1500 mA maximum should be used. A bulk cap (2.2 -10 μ F) should be placed on each side of each ferrite bead to ground to stop switching noise from traveling through the ferrite.

In addition, a high-frequency bypass cap (.01 μ f) should be placed near each analog VCC pin to ground.

3.3.1.2 Ground Noise

The best approach to minimize ground noise is strict use of good general design guidelines and by filtering the VCC plane.

3.3.1.3 Power and Ground Plane Layout Considerations

The power and ground planes should be laid out carefully. The following guidelines are recommended:

- Follow the guidelines in the LXT98x0 Repeater *Design and Layout Guide* for locating the split between the digital and analog VCC planes.
- Keep the digital VCC plane away from the TPOP/N and TPIP/N signals, magnetics, and RJ-45 connectors.
- Place the layers so the TPOP/N and TPIP/N signals are routed near or next to the ground plane. For EMI, it is more important to shield TPOP/N than TPIP/N.

3.3.1.4 Chassis Ground

For ESD protection, create a separate chassis ground. For isolation, encircle the board and place a “moat” around the signal ground plane to separate signal ground from chassis ground. Chassis ground should extend from the RJ-45 connectors to the magnetics, and can be used to terminate unused signal pairs (‘Bob Smith’ termination). In single-point grounding applications, provide a single connection between chassis and circuit grounds with a 2 kV isolation capacitor. In multi-point grounding schemes (chassis and circuit grounds joined at multiple points), provide 2 kV isolation to the Bob Smith termination.

3.3.1.5 The RBIAS Pin

The LXT98x0 Repeater requires a 22.1 k Ω , 1% resistor directly connected between the RBIAS pin and ground. Place the RBIAS resistor as close to the RBIAS pin as possible. Run an etch directly from the pin to the resistor, sink the other side of the resistor, and surround the RBIAS trace with a filtered ground. *Do not run high-speed signals next to RBIAS.*

Figure 21 Power and Ground Connections

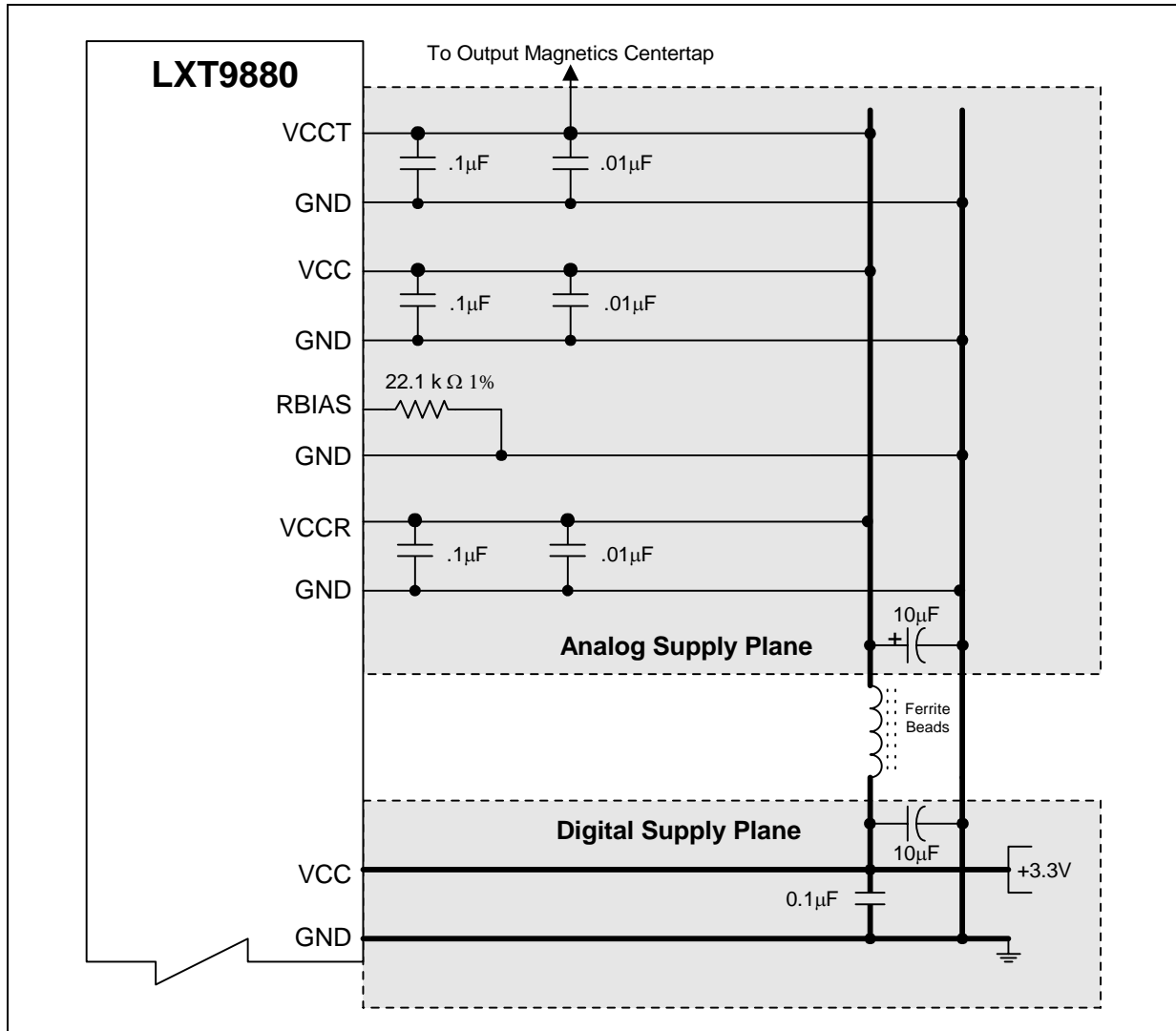

3.3.2 MII Terminations

The LXT98x0 Repeater MIIs have high output impedance (250-350 Ω). To minimize reflections, serial termination resistors are recommended on all MII signals, especially with designs with long traces (>3 inches). Place the resistor as close to the device as possible. Use a software trace termination package to select an optimal resistance value for the specific trace. Proper value = nominal trace impedance minus 13 Ω. If a software package cannot be used and nominal trace impedance is not known, use 55 Ω.

3.3.3 Twisted-Pair Interface

The LXT98x0 Repeater transmitter uses standard 1:1 magnetics for both receive and transmit. Nonetheless, system designers should take precautions to minimize parasitic shunt capacitance and meet return loss specifications. These steps include:

- Place magnetics as close as possible to the LXT98x0 Repeater.
- Keep transmit pair traces short.
- Do not route transmit pair adjacent to a ground plane. Eliminate planes under the transmit traces completely. Otherwise, keep planes 3-4 layers away.
- Improve EMI performance by filtering the output center tap supply. A single ferrite bead may be used in the center tap supply to all ports. A ferrite bead with a total maximum current rating of 1.5 Amp is recommended.
- Place 270 pF 5% capacitors at TPIP and TPIN to improve signal-to-noise immunity at the receiver, especially for long line lengths.

In addition, follow all the standard guidelines for a twisted-pair interface:

- Route the signal pairs differentially, close together. Allow nothing to come between them.
- Keep distances as short as possible; both traces should have the same length.
- Avoid vias and layer changes.
- Keep the transmit and receive pairs apart to avoid cross-talk.
- To provide maximum isolation, place entire receive termination network on one side and transmit on the other side of the PCB.
- Bypass common-mode noise to ground on the in-board side of the magnetics using 0.01 μ F capacitors.
- Keep termination circuits grouped closely together and on the same side of the board.
- Always put termination circuits close to the source end of any circuit.

3.3.3.1 Magnetics Information

The LXT98x0 Repeater requires a 1:1 ratio for the receive transformers and a 1:1 ratio for the transmit transformers. The transformer isolation voltage should be rated at 2 kV to protect the circuitry from static voltages across the connectors and cables. Refer to [Table 25](#) for magnetics specifications.

Table 25 LXT98x0 Repeater Magnetics Specifications (Sheet 1 of 2)

Parameter	Min	Nom	Max	Units	Test Condition
Rx turns ratio	–	1 : 1	–	–	
Tx turns ratio	–	1 : 1	–	–	
Insertion loss	0.0	–	1.1	dB	80 MHz
Primary inductance	350	–	–	μ H	
Transformer isolation	–	2	–	kV	

Table 25 LXT98x0 Repeater Magnetics Specifications (Sheet 2 of 2)

Parameter	Min	Nom	Max	Units	Test Condition
Differential to common mode rejection	-40	-		dB	.1 to 60 MHz
	-35	-		dB	60 to 100 MHz
Return Loss - standard	-16	-		dB	30 MHz
	-10	-		dB	80 MHz

3.3.4 Clock

A stable, external 25 MHz system clock source (CMOS) is required. See [Table 26](#).

Table 26 Oscillator Manufacturers

Manufacturer	Part Number	Frequency
CTS	MXO45 / 45LV	25 MHz
Epson America	SG-636 Series	25 MHz

Figure 22 Typical Twisted-Pair Port Interface and Power Supply Filtering

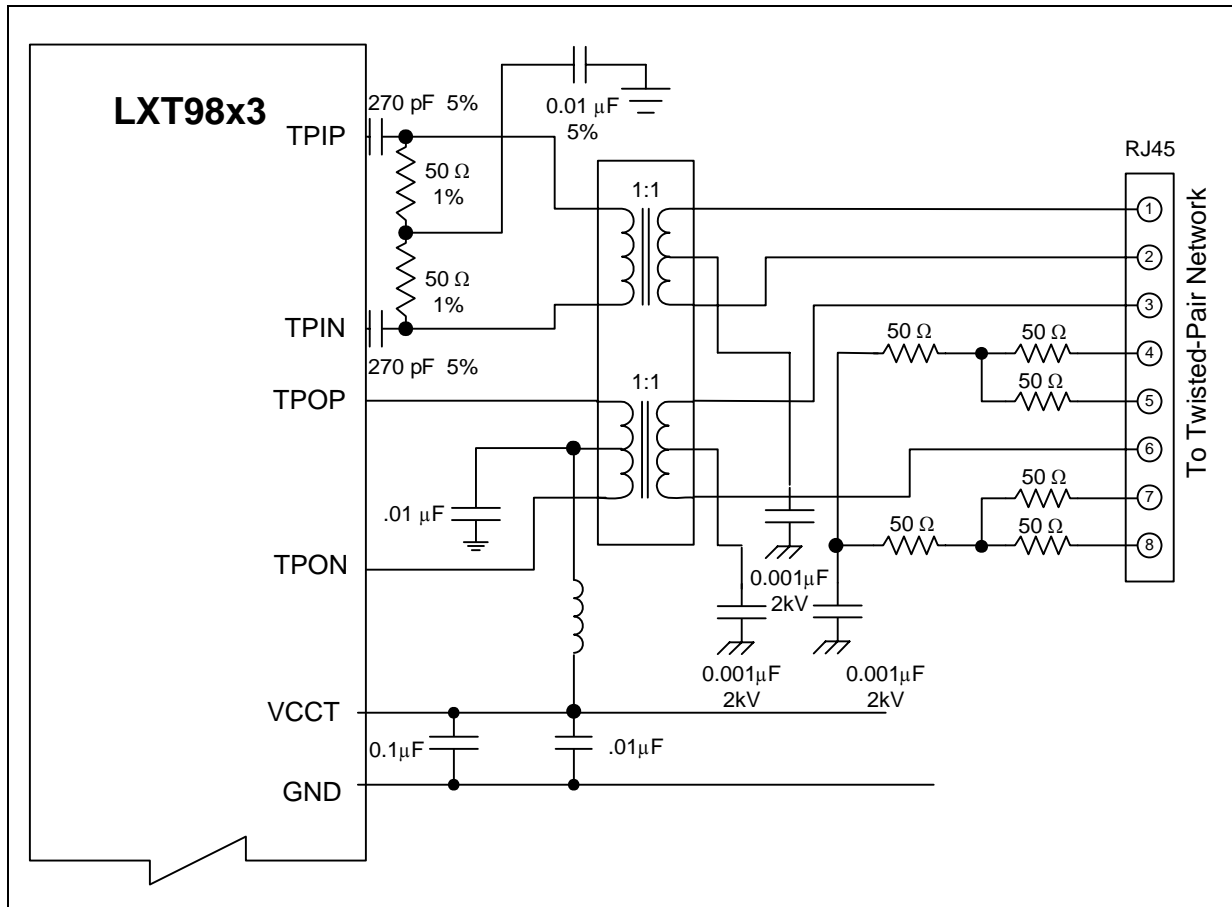

3.3.5 SMI and PROM Circuits

Figure 23 Typical Serial Management Interface Connections

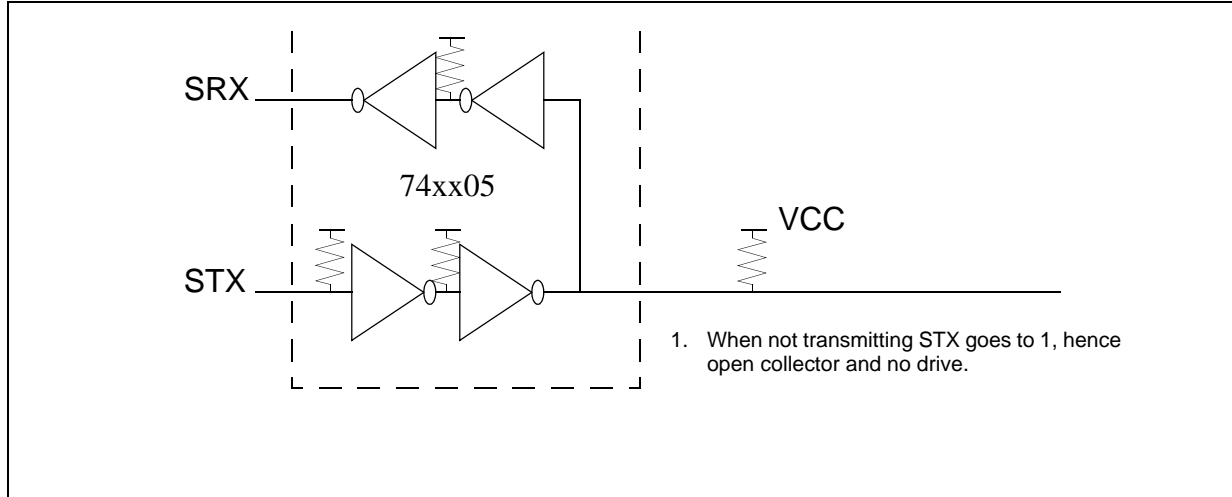

Figure 24 Serial Controller Connection Showing PAL

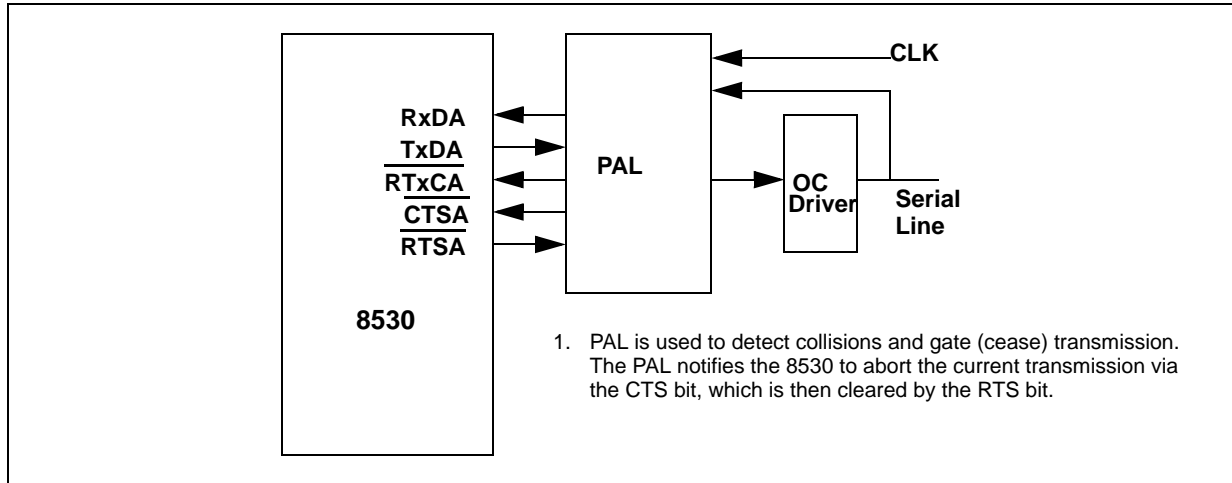

Figure 25 Serial PROM Interface

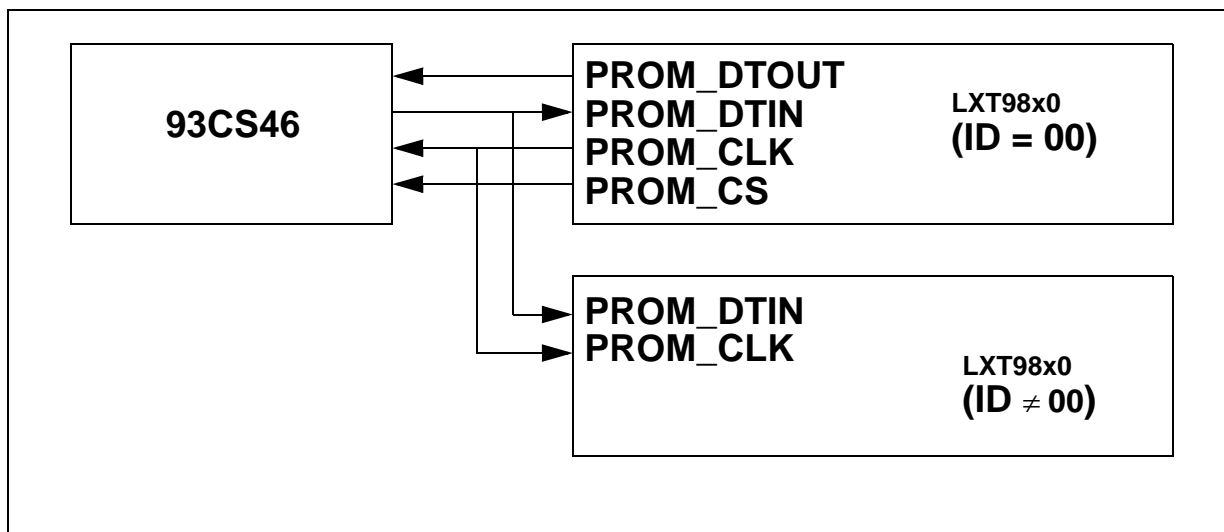
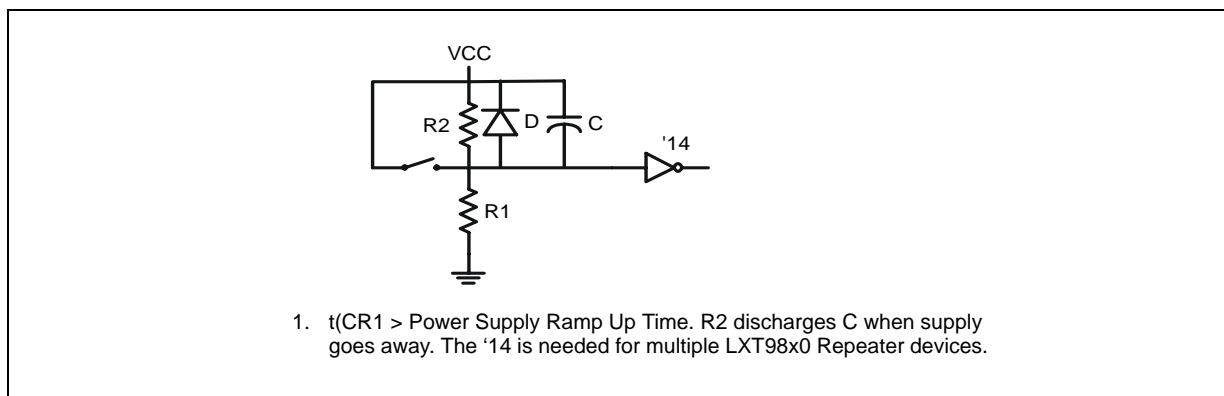

Figure 26 Typical Reset Circuit



3.3.6 LED Circuits

3.3.6.1 Direct Drive LEDs

Each Direct Drive LED has a corresponding open-drain pin. The LEDs are connected, via a current limiting resistor, to a positive voltage rail. The LEDs are turned on when the output pin drives Low. The open-drain LED pins are 5 V tolerant, allowing use of either a 3.3 V or 5 V rail. A 5 V rail eases LED component selection by allowing more common, high forward voltage LEDs to be used. Refer to [Figure 27](#) for a circuit illustration.

3.3.6.2 LED Pins Multiplexed with Configuration Inputs

Some static configuration inputs are multiplexed with LED pins to reduce the LXT98x0 Repeater pin count. These LED pins are configured by current sinking (open-drain output) and sourcing (open-source output). If the LED pin sinks the LED current, the configuration value is '1'. If LED pin sources the current, the configuration value is a '0'.

The LXT98x0 Repeater detects the configuration value following reset and then selects the appropriate output drive circuit (open drain or source). If the LED function of a multiplexed configuration pin is not used, tie the pin to Ground or V_{cc} via a 100–500 k Ω resistor to set the configuration value. Multiple LED configuration pins can be tied off with a single resistor to set them all to the same value. Refer to [Figure 27](#) for a circuit illustration.

For configuration values of '1', a 3.3 V or a 5 V rail can be used to drive the LEDs (to ease LED selection as with Direct Drive LEDs).

For configuration values of '0', external buffering is used when 5 V LED driving is desired. (This buffering could be as simple as a single transistor.) As an alternative, use the copies of the multiplexed LED data found on the LED serial interface. If a 5 V tolerant serial-to-parallel device is used for the LED serial interface, 5 V LED driving is achieved (see [Section 3.3.6.3, Serial LEDs, on page 68](#)).

Figure 27 LED Circuits - Direct Drive & Multiplexed Configuration Inputs

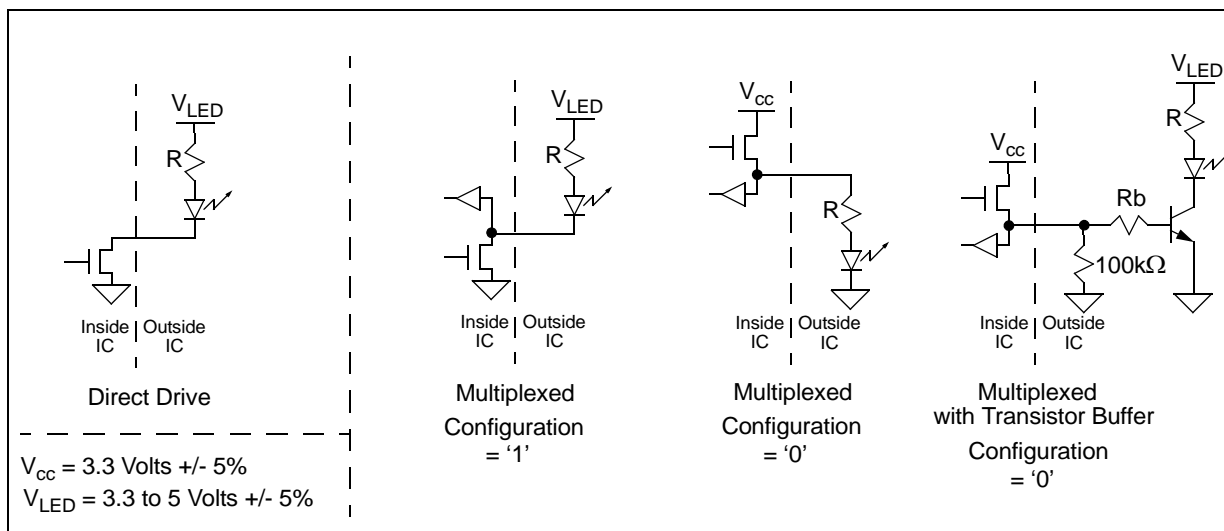

3.3.6.3 Serial LEDs

The LXT98x0 Repeater provides a serial interface to support additional LED options. Standard shift registers, either 74X595s (8-bit Serial-to-Parallel with Output Registers) or 74X164s (8-bit S/P without registers) can be used to drive these additional LEDs. Collision10/100 and Activity10/100 status indications are provided on multiplexed configuration pins and duplicated on the serial port.

The LED serial interface consists of three outputs: clock (LEDCLK), parallel latch clock (LEDLAT), and output data (LEDDAT). The parallel latch clock is used only with the 74X595 implementation. Refer to [Figure 28](#) for an illustration of the LED serial interface circuit.

Potentially, 30 LEDs can be driven by the LED serial interface via 4 S/P devices. The S/P serial output is connected to the serial input of the first serial input device. To expand the chain, connect the last serial output to serial input of next serial interface device.

Serial LED data is output in the anticipated priority order, from least likely to most likely to be used:

- Unused '595/'164 parallel outputs

- MII Ports - LED1, 2, 3
- Miscellaneous LEDs (Repeat of Collision10/100, Manager Present, Repeat of Activity10/100, Global Fault, RPS Fault)
- ACTGLED10
- ACTGLED100

This allows the user to leave off devices in the serial-to-parallel chain if the LEDs associated with that condition aren't desired. Refer to [Figure 7 on page 39](#) which illustrates the LED serial interface port signalling and [Table 12 on page 39](#) which documents the Serial LED Stream.

If the 8 bit serial bus Configuration Mode is selected (See [Section 2.12, Serial Configuration Interface, on page 58.](#)), unscheduled (less than 122 ms apart) LED Serial Port cycles occur each time the Repeater Serial Configuration register is read. If the 74x164 buffer is used, flicker is minimized by design so that it is not noticeable to the eye. The LED outputs may change momentarily.

Figure 28 Serial LED Circuit

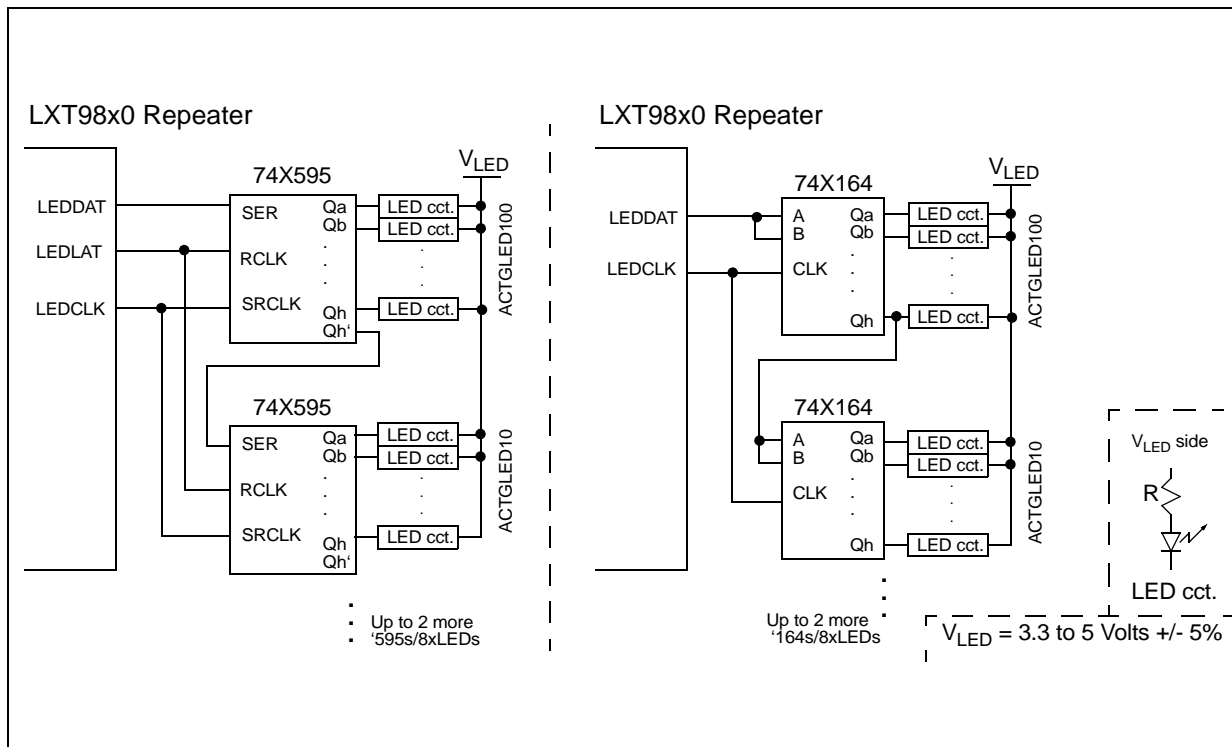

3.4 Inter-Repeater Backplane Compatibility

The Inter-repeater Backplane (IRB) comprises two parts:

- Local—the backplane between cascaded devices on the same board.
- Stack—the backplane between multiple boards.

Each of these backplanes consists of both analog and digital signals.

3.4.1 Local Backplane—3.3 V Only

The LXT98x0 Repeater local backplane operates at 3.3 V only. LXT98x and LXT91x devices operate at 5 V. LXT98x0 Repeater devices are, therefore, not cascadable with LXT98x and LXT91x devices.

Note: Do not mix LXT98x0 Repeater with either LXT98x or LXT91x devices on the local backplanes.

3.4.2 Stack Backplane—3.3 V or 5 V

The LXT98x0 Repeater stack backplanes can be configured to be either 3.3 V or 5 V. COMP_SEL (Pin 39), a special input pin, selects between the two voltage modes, depending on whether 3.3 V or 5 V is applied.

3.3 V-Only Stacks Apply 3.3 V to COMP_SEL, $\overline{\text{IR100CFSBP}}$, $\overline{\text{IR10CFSBP}}$, and IR10COLBP for LXT98x0 Repeater backplane operation

For 5 V Backwards

Stackability Apply 5 V to COMP_SEL, $\overline{\text{IR100CFSBP}}$, $\overline{\text{IR10CFSBP}}$, and IR10COLBP for LXT98x and LXT91x backplane operation.

With either mode (3.3 V or 5 V), COMP_SEL draws less than 3 mA.

Notes:

1. The external pull-up resistor values remain the same, regardless of 3.3 V or 5 V backplane operation.
2. The recommended digital signal external buffer has been changed to 74LVT245 for the LXT98x0 Repeater.

3.4.2.1 3.3 V and 5.0 V Stacking Boards Cannot Be Mixed

3.4.2.1.1 3.3 V Operation

Boards designed for 3.3 V backplane operation should only be stacked with other 3.3 V boards. Existing LXT98x or LXT91x based designs cannot operate in 3.3 V.

Incompatible Stacking

Configurations The following stacking configurations are incompatible:

- A LXT98x0 Repeater-based board configured for 3.3 V backplane operation and LXT98x or LXT91x based boards (5 V only).
- A LXT98x0 Repeater-based board configured for 3.3 V backplane operation and a LXT98x0 Repeater-based board configured for 5 V backplane operation.

Note: Stacking boards designed for 3.3 V backplane operation with boards designed for 5 V backplane operation causes network errors.

3.4.2.1.2 5 V Operation

Boards designed for 5 V backplane operation should only be stacked with other 5 V boards:

- LXT98x or LXT91x-based designs.
- LXT98x0 Repeater designs configured for 5 V backplane operation.

The configuration input must be connected to 5 V for compatibility with LXT98x or LXT91x-based designs. The 5 V can be supplied from the stacking cable, or a 5 V source must exist within the board itself.

Note: Stacking boards designed for 5 V backplane operation with boards designed for 3.3 V backplane operation causes network errors.

Figure 29 100 Mbps Backplane Connection between LXT98x and LXT98x0 Repeater

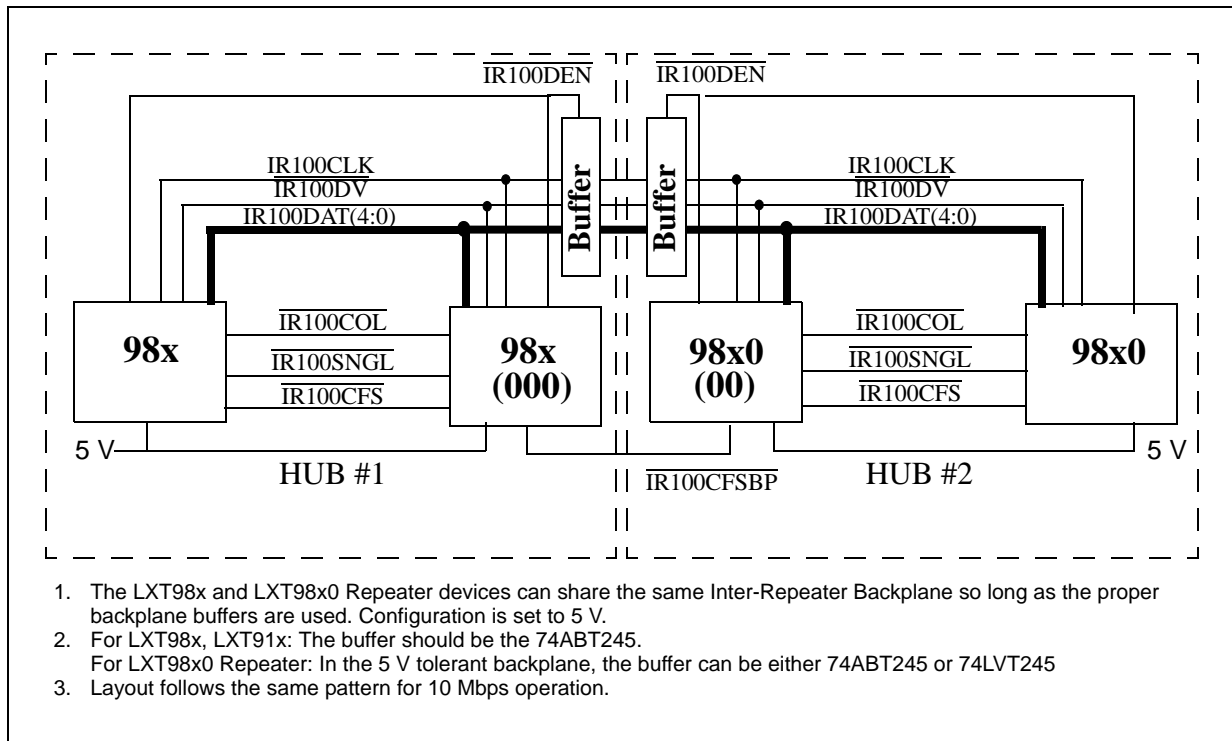

Figure 30 Typical 100 Mbps IRB Implementation

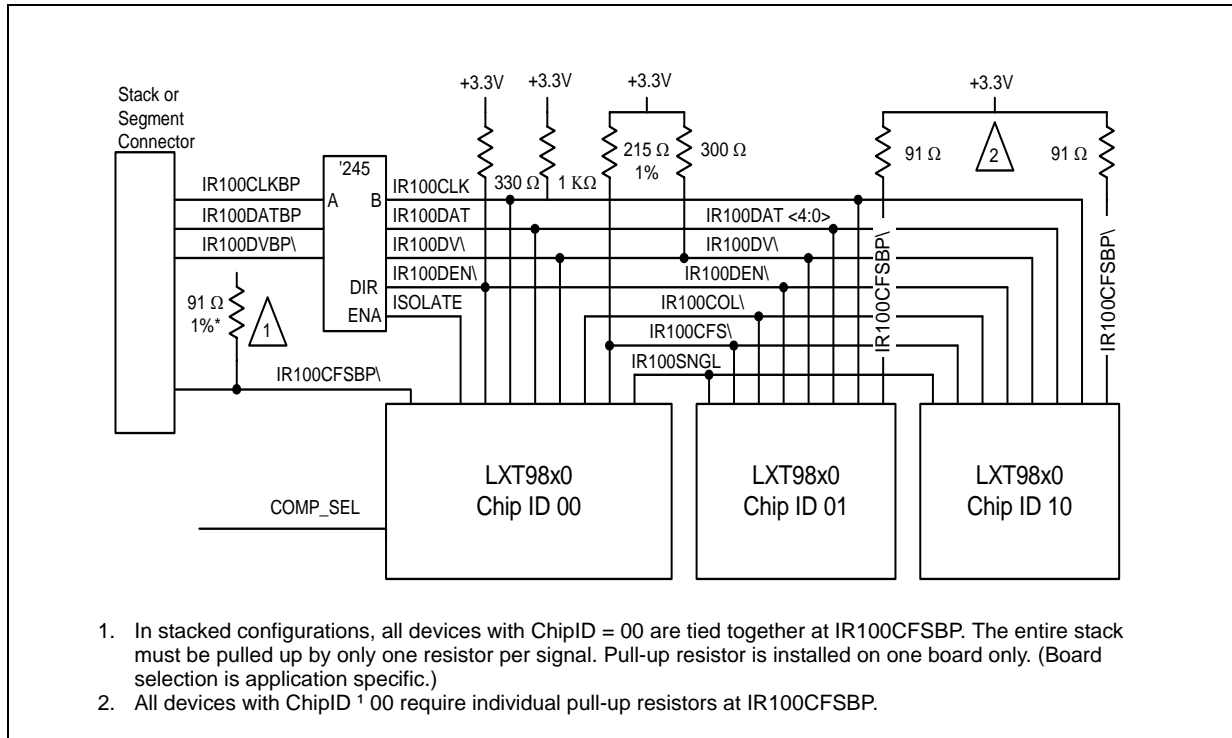
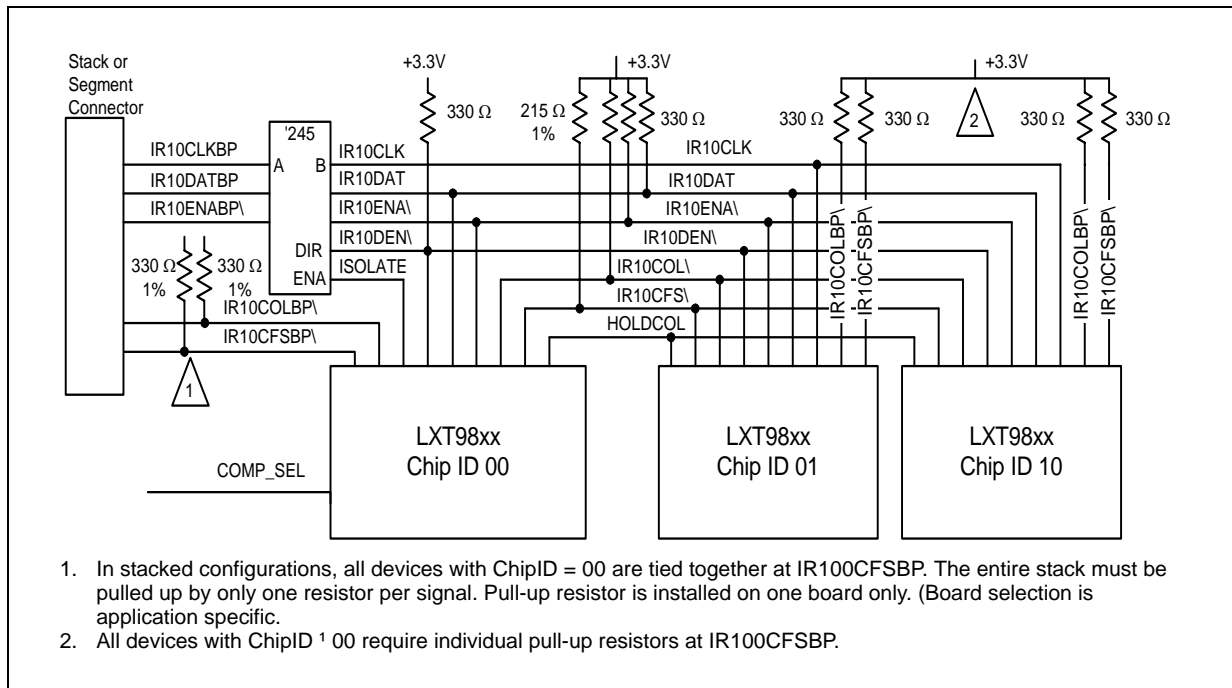

Figure 31 Typical 10 Mbps IRB Implementation



4.0 Test Specifications

Note: Table 27 through Table 44 and Figure 32 through Figure 41 represent the target specifications of the LXT98x0 Repeater and are subject to change. Final values will be guaranteed by test except, where noted, by design. The minimum and maximum values listed in Table 29 through Table 44 will be guaranteed over the recommended operating conditions specified in Table 28.

Table 27 Absolute Maximum Ratings

Parameter	Symbol	Min	Max	Units
Supply voltage	VCC	-0.3	4.0	V
Storage temperature	TST	-65	+150	°C
Caution: Exceeding these values may cause permanent damage. Functional operation under these conditions is not implied. Exposure to maximum rating conditions for extended periods may affect device reliability.				

Table 28 Operating Conditions

Parameter	Sym	Min	Typ ¹	Max	Units	
Recommended supply voltage	VCC	3.15	3.3	3.45	V	
	VCCR	3.15	3.3	3.45	V	
	VcCT	3.15	3.3	3.45	V	
Recommended operating temperature						
Commercial Temperature Range	Ambient	TOPA	0	–	70	°C
	Case	TOPC	0	–	115	°C
Extended Temperature Range	Ambient	TOPA	-40	–	+85	°C
	Case	TOPC	-18	–	+120	°C
Power consumption	8 ports active	PC	–	–	3.03	W
	6 ports active	PC	–	–	2.50	W
1. Typical values are at 25° C and are for design aid only; they are not guaranteed and not subject to production testing.						

Table 29 Input System Clock¹ Requirements

Parameter ²	Sym	Min	Typ ³	Max	Units	Test Conditions
Frequency	–	–	25	–	MHz	–
Frequency Tolerance	–	–	–	±100	PPM	–
Duty Cycle	–	40	–	60	%	–
1. The system clock is CLK25 (Pin 54). 2. These requirements apply to the external clock supplied to the LXT98x0 Repeater, not to LXT98x0 Repeater test specifications. 3. Typical values are at 25 °C and are for design aid only; not guaranteed and not subject to production testing.						

Table 30 I/O Electrical Characteristics

Parameter	Sym	Min	Typ ¹	Max	Units	Test Conditions
Input Low voltage	V _{IL}	–	–	0.8	V	TTL inputs
		–	–	30	% V _{CC}	CMOS inputs ²
		–	–	1.0		Schmitt triggers ³
Input High voltage	V _{IH}	2.0	–	–	V	TTL inputs
		70	–	–	% V _{CC}	CMOS inputs ²
		V _{CC} - 1.0	–	–	V	Schmitt triggers ³
Hysteresis voltage	–	1.0	–	–	V	Schmitt triggers ³
Output Low voltage	V _{OL}	–	–	0.4	V	I _{OL} = 1.6 mA
Output Low voltage (LED)	V _{OLL}	–	–	1.0	V	I _{OLL} = 10 mA
Output High voltage	V _{OH}	2.2	–	–	V	I _{OH} = 40 μA
Input Low current	I _{IL}	-100	–	–	μA	–
Input High current	I _{IH}	–	–	100	μA	–
Output rise / fall time	TRF	–	3	10	ns	C _L = 15 pF

1. Typical values are at 25 °C and are for design aid only; not guaranteed and not subject to production testing.
 2. Does not apply to IRB pins. Refer to [Table 31](#) and [Table 32](#) for IRB I/O characteristics.
 3. Applies to RESET, CLK25, IR100SNGL, IR100COL, IR100DAT_n, IR100CLK, and IR10CLK pins.

Table 31 100 Mbps IRB Electrical Characteristics (Sheet 1 of 2)

Parameter	Sym	Min	Typ ¹	Max	Units	Test Conditions
Output Low voltage	V _{OL}	–	.3	.7	V	R _L = 330 Ω
Output rise or fall time	TRF	–	4	10	ns	C _L = 15 pF
Input High voltage	V _{IH}	V _{CC} - 2.0	–	–	V	CMOS inputs
		V _{CC} - 1.0	–	–	V	IR100CLK (Schmitt trigger)
Input Low voltage	V _{IL}	–	–	2.0	V	CMOS inputs
		–	–	1.0		IR100CLK (Schmitt trigger)
Hysteresis voltage	–	1.0	–	–	V	IR100CLK (Schmitt trigger)
3.3 V Operation						
$\overline{\text{IR100CFS}}$ current	single drive	–	–	6.8	–	mA R _L = 215 Ω
	collision	–	–	13.5	–	mA R _L = 215 Ω
$\overline{\text{IR100CFSBP}}$ current	single drive	–	–	16.1	–	mA R _L = 91 Ω ²
	collision	–	–	31.8	–	mA R _L = 91 Ω ²
$\overline{\text{IR100CFS/BP}}$ voltage	single drive	–	–	1.83	–	V –
	collision	–	–	0.4	–	V –

1. Typical values are at 25° C and are for design aid only; they are not guaranteed and not subject to production testing.
 2. 91 Ω resistors provide greater noise immunity. Systems using 91 Ω resistors are backwards stackable with systems using 100 Ω resistors.

Table 31 100 Mbps IRB Electrical Characteristics (Sheet 2 of 2)

Parameter	Sym	Min	Typ ¹	Max	Units	Test Conditions
5.0 V Operation						
$\overline{IR100CFS}$ current	single drive	–	–	N/A	–	mA RL = 215 Ω
	collision	–	–	N/A	–	mA RL = 215 Ω
$\overline{IR100CF SBP}$ current	single drive	–	–	24.2	–	mA RL = 91 Ω^2
	collision	–	–	42	–	mA RL = 91 Ω^2
$\overline{IR100CFS/BP}$ voltage	single drive	–	–	2.8	–	V –
	collision	–	–	0.6	–	V –
1. Typical values are at 25° C and are for design aid only; they are not guaranteed and not subject to production testing. 2. 91 Ω resistors provide greater noise immunity. Systems using 91 Ω resistors are backwards stackable with systems using 100 Ω resistors.						

Table 32 10 Mbps IRB Electrical Characteristics

Parameter	Sym	Min	Typ ¹	Max	Units	Test Conditions
Output Low voltage	VOL	0	.1	.4	V	RL = 330 Ω
Output rise or fall time	TRF	–	4	10	ns	CL = 15 pF
Input High voltage	VIH	VCC - 2.0	–	–	V	CMOS inputs
		VCC - 2.0	–	–	V	IR10CLK (Schmitt trigger)
Input Low voltage	VIL	–	–	2.0	V	CMOS inputs
		–	–	1.0	V	IR10CLK (Schmitt trigger)
Hysteresis voltage	–	0.5	–	–	V	IR10CLK (Schmitt trigger)
3.3 V Operation						
$\overline{IR10CFS}$ current	single drive	–	–	6.8	–	mA RL = 215 Ω
	collision	–	–	13.5	–	mA RL = 215 Ω
$\overline{IR10CF SBP}$ current	single drive	–	–	4.5	–	mA RL = 330 Ω
	collision	–	–	8.8	–	mA RL = 330 Ω
$\overline{IR10CFS/BP}$ voltage	single drive	–	1.3	1.83	2.4	V –
	collision	–	0.2	0.4	0.6	V –
5.0 V Operation						
$\overline{IR10CFS}$ current	single drive	–	–	N/A	–	mA RL = 215 Ω
	collision	–	–	N/A	–	mA RL = 215 Ω
$\overline{IR10CF SBP}$ current	single drive	–	–	7.0	–	mA RL = 330 Ω
	collision	–	–	13.5	–	mA RL = 330 Ω
$\overline{IR10CFS/BP}$ voltage	single drive	–	1.9	2.8	3.2	V –
	collision	–	0.4	0.6	0.8	V –
1. Typical values are at 25° C and are for design aid only; they are not guaranteed and not subject to production testing.						

Table 33 100BASE-TX Transceiver Electrical Characteristics

Parameter	Sym	Min	Typ ¹	Max	Units	Test Conditions
Peak differential output voltage (single ended)	Vp	0.95	1.0	1.05	V	Note 2
Signal amplitude symmetry	–	98	–	102	%	Note 2
Signal rise/fall time	Trf	3.0	–	5.0	ns	Note 2
Rise/fall time symmetry	Trfs	–	–	0.5	ns	Note 2
Duty cycle distortion	–	–	–	+/- 0.5	ns	Offset from 8 ns pulse width at 50% of pulse peak,
Overshoot	Vo	–	–	5	%	–

1. Typical values are at 25 °C and are for design aid only; not guaranteed and not subject to production testing.
 2. Measured at line side of transformer, line replaced by 100Ω (±1%) resistor.

Table 34 10BASE-T Transceiver Electrical Characteristics

Parameter	Sym	Min	Typ ¹	Max	Units	Test Conditions
Transmitter						
Peak differential output voltage	Vp	2.2	2.5	2.8	V	Measured at line side of transformer, line replaced by 100Ω (±.1%) resistor
Transmit timing jitter addition ²	–	8	–	24	ms	0 line length for internal MAU
Transmit timing jitter added by the MAU and PLS sections ^{2,3}	–	0	–	11	ns	After line model specified by IEEE 802.3 for 10BASE-T internal MAU
Receiver						
Receive input impedance	ZIN	–	20	–	kΩ	Between TPIP/TPIN
Differential Squelch Threshold	VDS	–	390	–	mV	5 MHz square wave input, 750 mVpp

1. Typical values are at 25 °C and are for design aid only; not guaranteed and not subject to production testing.
 2. Parameter is guaranteed by design; not subject to production testing.
 3. IEEE 802.3 specifies maximum jitter additions at 1.5 ns for the AUI cable, 0.5 ns from the encoder, and 3.5 ns from the MAU.

Figure 32 100 Mbps TP Port-to-Port Delay Timing

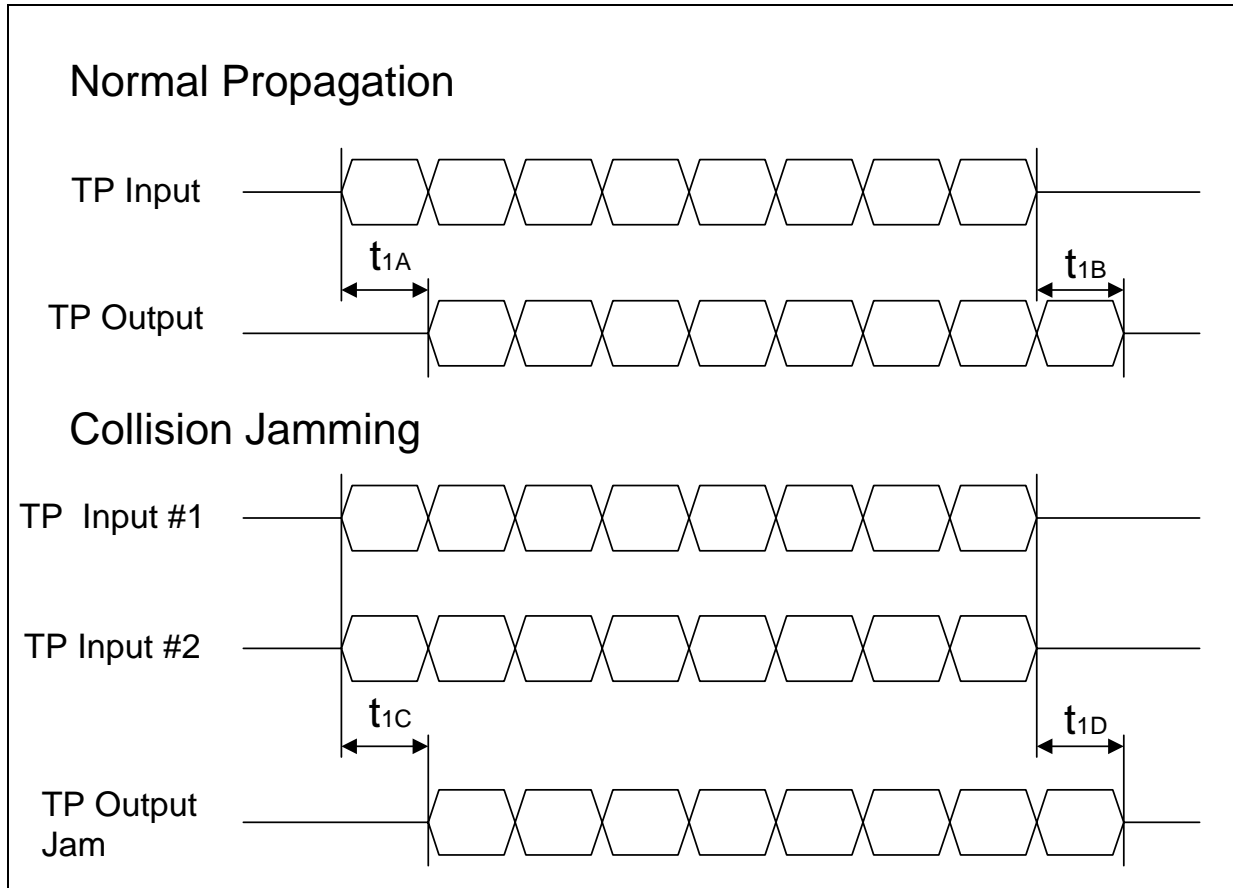

Table 35 100 Mbps TP Port-to-Port Delay Timing Parameters

Parameter	Sym	Min	Typ ¹	Max	Units ²	Test Conditions
TPIP/N to TPOP/N, start of transmission	t _{1A}	–	–	46	BT	–
TPIP/N to TPOP/N, end of transmission	t _{1B}	–	–	46	BT	–
TPIP/N collision to TPOP/N, start of jam	t _{1C}	–	–	46	BT	–
TPIP/N idle to TPOP/N, end of jam	t _{1D}	–	–	46	BT	–

1. Typical values are at 25 °C and are for design aid only; not guaranteed and not subject to production testing.
 2. Bit Time (BT) is the duration of one bit as transferred to/from the MAC and is the reciprocal of bit rate. BT for 100BASE-T = 10⁻⁸ s or 10 ns.

Figure 33 100BASE-TX MII-to-TP Port Timing

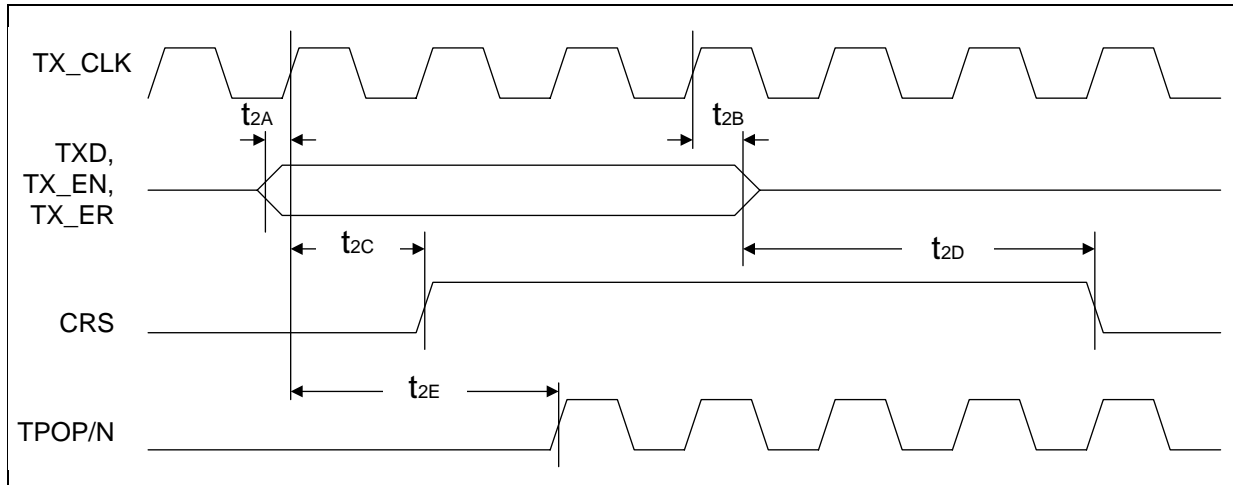

Table 36 100BASE-TX MII-to-TP Port Timing Parameters

Parameter	Sym	Min	Typ ¹	Max	Units ²	Test Condition
TXD, TX_EN, TX_ER Setup to TX_CLK High	t _{2A}	10	–	–	ns	–
TXD, TX_EN, TX_ER Hold from TX_CLK High	t _{2B}	5	–	–	ns	–
TX_EN sampled to CRS asserted	t _{2C}	0	–	4	BT	–
TX_EN sampled to CRS de-asserted	t _{2D}	0	–	16	BT	–
TX_EN sampled to TPOP/N active (Tx latency)	t _{2E}	–	–	46	BT	–

1. Typical values are at 25 °C and are for design aid only; not guaranteed and not subject to production testing.
 2. Bit Time (BT) is the duration of one bit as transferred to/from the MAC and is the reciprocal of bit rate. BT for 100BASE-T = 10⁻⁸ s or 10 ns.

Figure 34 100BASE-TX TP-to-MII Timing

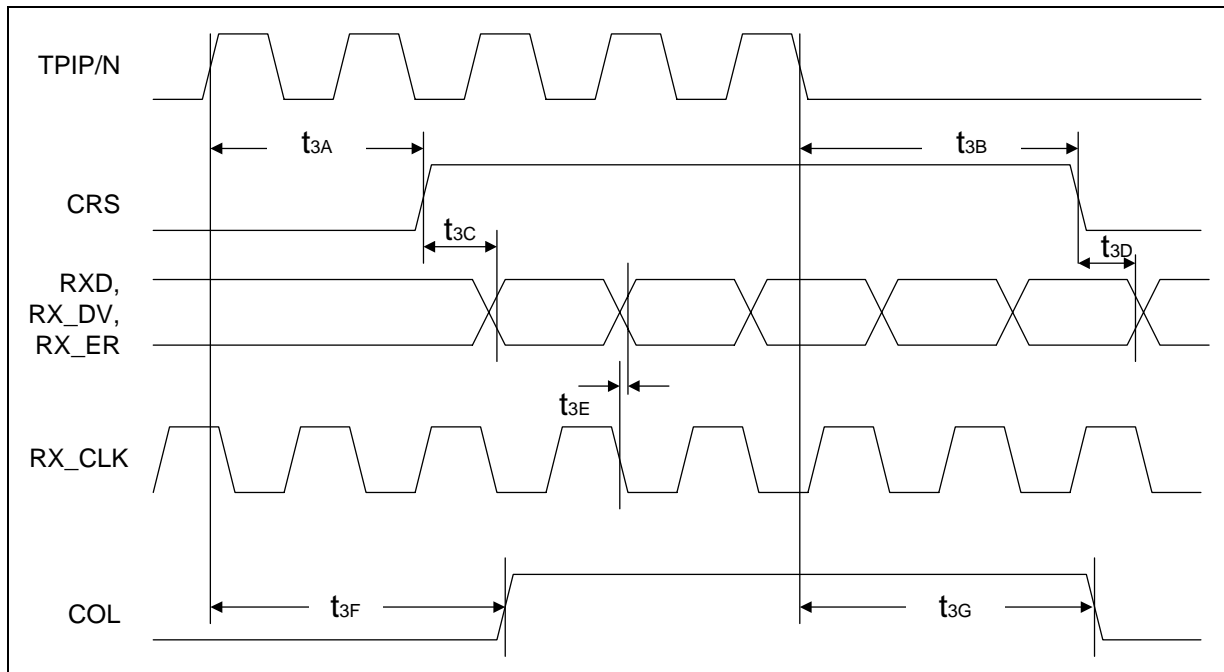

Table 37 100BASE-TX TP-to-MII Timing Parameters

Parameter	Sym	Min	Typ ¹	Max	Units ²	Test Conditions
TPIP/N in to CRS asserted	t3A	–	–	46	BT	–
TPIP/N quiet to CRS de-asserted	t3B	–	–	46	BT	–
CRS asserted to RXD, RX_DV, RX_ER	t3C	1	–	4	BT	–
CRS de-asserted to RXD, RX_DV, RX_ER de-asserted	t3D	–	–	3	BT	–
RX_CLK falling edge to RXD, RX_DV, RX_ER valid	t3E	–	–	10	ns	–
TPIP/N in to COL asserted	t3F	–	–	46	BT	–
TPIP/N quiet to COL de-asserted	t3G	–	–	46	BT	–

1. Typical values are at 25 °C and are for design aid only; not guaranteed and not subject to production testing.
 2. Bit Time (BT) is the duration of one bit as transferred to/from the MAC and is the reciprocal of bit rate. BT for 100BASE-T = 10⁻⁸ s or 10 ns.

Figure 35 10BASE-T MII-to-TP Timing

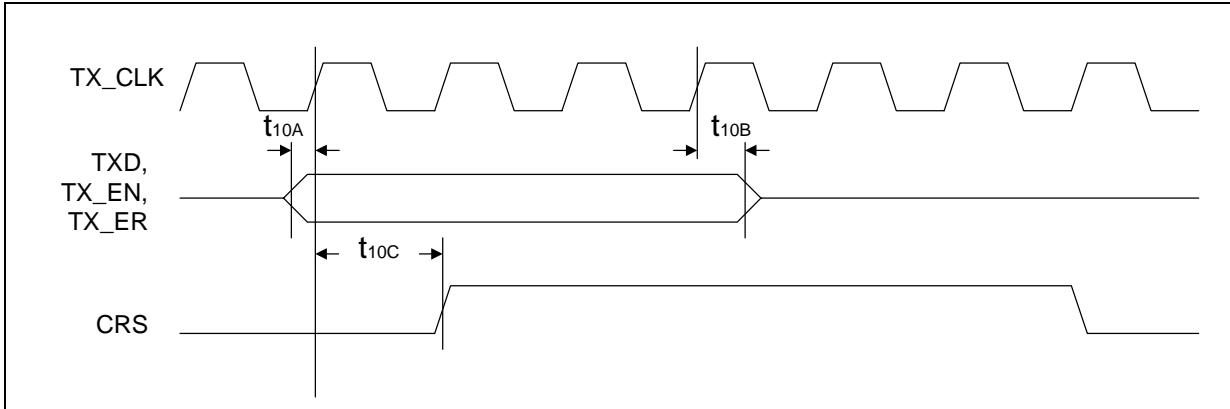

Table 38 10BASE-T MII-to-TP Timing Parameters

Parameter	Sym	Min	Typ ¹	Max	Units ²	Test Conditions
TXD, TX_EN, TX_ER Setup to TX_CLK High	t10A	10	–	–	ns	–
TXD, TX_EN, TX_ER Hold from TX_CLK High	t10B	5	–	–	ns	–
TX_EN sampled to CRS asserted	t10C	0	.9	2	BT	–

1. Typical values are at 25 °C and are for design aid only; not guaranteed and not subject to production testing.
 2. Bit Time (BT) is the duration of one bit as transferred to/from the MAC and is the reciprocal of bit rate. BT for 10BASE-T = 10⁻⁷ s or 100 ns.

Figure 36 10BASE-T TP-to-MII Timing

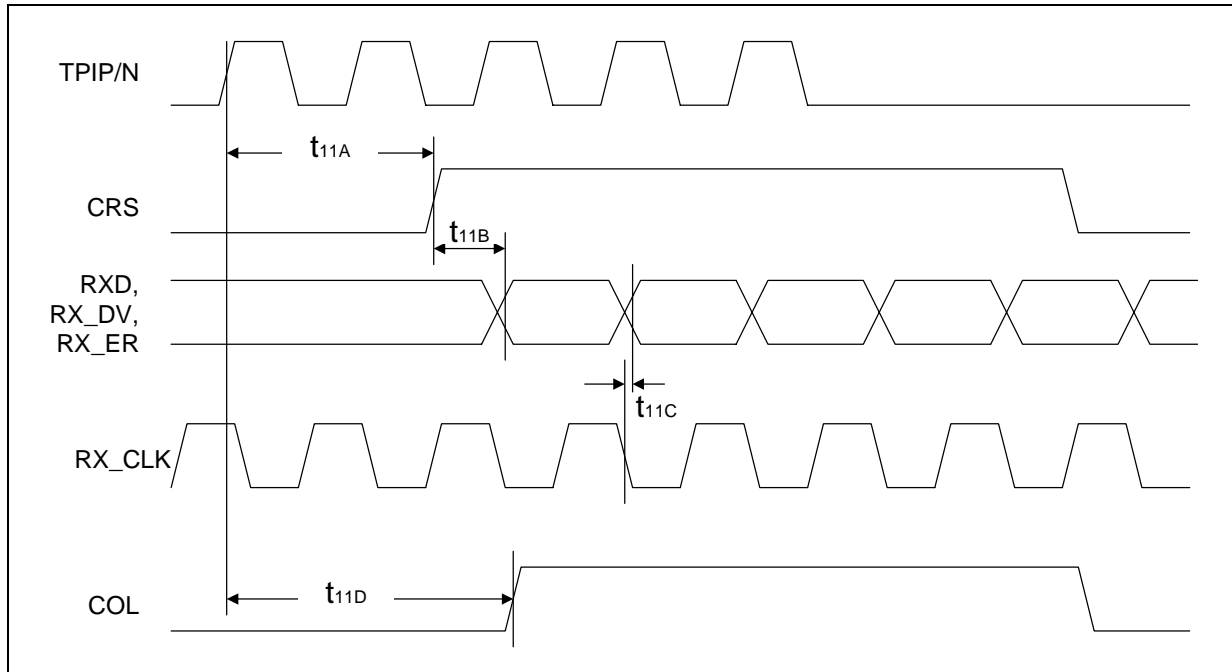

Table 39 10BASE-T TP-to-MII Timing Parameters

Parameter	Sym	Min	Typ ¹	Max	Units ²	Test Conditions
TPIP/N in to CRS asserted	t _{11A}	5	6.6	8	BT	–
CRS asserted to RXD, RX_DV, RX_ER	t _{11B}	70	76	84	BT	–
RX_CLK falling edge to RXD, RX_DV, RX_ER valid	t _{11C}	–	–	10	ns	–
TPIP/N in to COL asserted	t _{11D}	6	7.4	9	BT	–

1. Typical values are at 25 °C and are for design aid only; not guaranteed and not subject to production testing.
 2. Bit Time (BT) is the duration of one bit as transferred to/from the MAC and is the reciprocal of bit rate. BT for 10BASE-T = 10⁻⁷s or 100 ns.

Figure 37 100 Mbps TP-to-IRB Timing

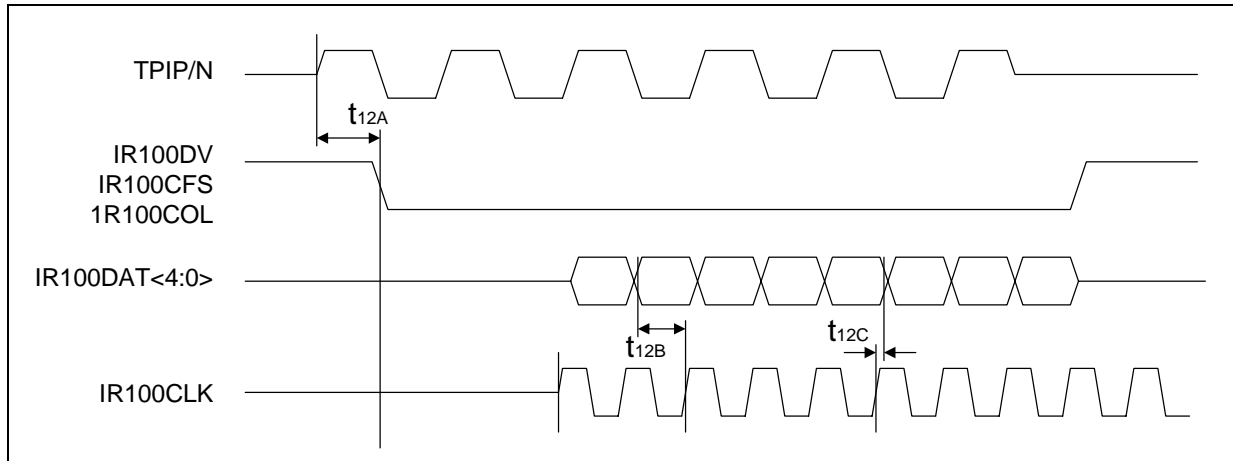

Table 40 100 Mbps TP-to-IRB Timing Parameters¹

Parameter	Sym	Min	Typ ²	Max	Units ³	Test Conditions
TPIP/N to IR100DV Low	t12A	17	24	30	BT	–
IR100DAT to IR100CLK setup time.	t12B	–	4	–	ns	–
IR100DAT to IR100CLK hold time.	t12C	–	0	–	ns	–

1. This table contains propagation delays from the TP ports to the IRB for normal repeater operation. All values in this table are output timings.
2. Typical figures are at 25 C and are for design aid only; not guaranteed and not subject to production testing.
3. Bit Time (BT) is the duration of one bit as transferred to/from the MAC and is the reciprocal of bit rate. BT for 100BASE-T = 10⁻⁸ s or 10 ns.

Figure 38 10 Mbps TP-to-IRB Timing

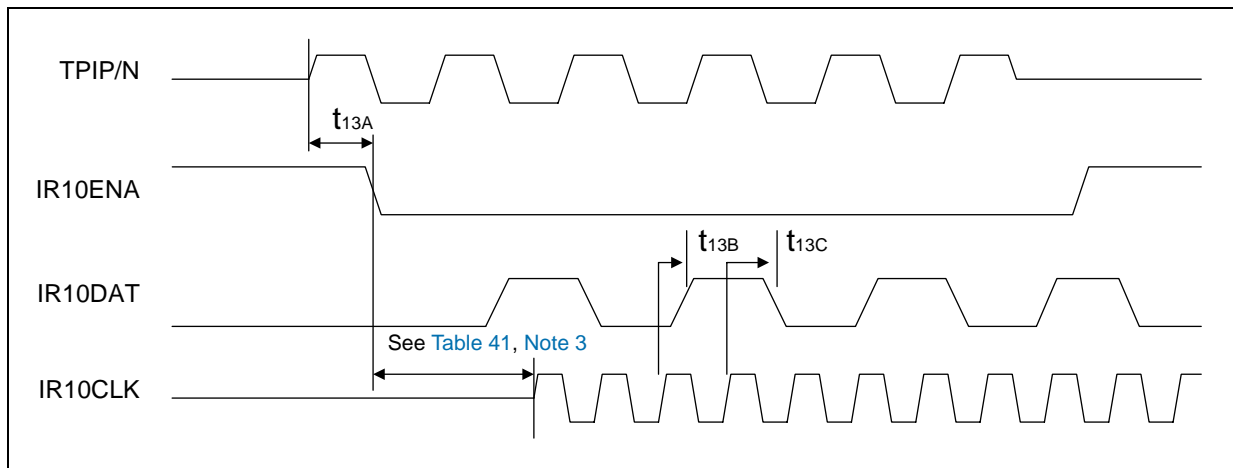

Table 41 10 Mbps TP-to-IRB Timing Parameters¹

Parameter ²	Sym	Min	Typ ³	Max	Units ⁴	Test Conditions
TPIP/N to IR10ENA Low	t13A	3	5.1	7	BT	–
IR10CLK rising edge to IR10DAT rising edge.	t13B	25	-	55	ns	330 Ω pull-up, 150 pF load on IR10DAT. 1 kΩ pull-up, 150 pF load on IRCLK.
IR10CLK rising edge to IR10DAT falling edge.	t13C	5	-	25	ns	

1. This table contains propagation delays from the TP ports to the IRB for normal repeater operation. All values in this table are output timings.
 2. There is a delay of approximately 13 to 16 bit times between the assertion of IR10ENA and the assertion of IR10CLK and IR10DAT. This delay does not affect repeater operation because downstream devices begin generating preamble as soon as IR10ENA is asserted.
 3. Typical values are at 25 °C and are for design aid only; not guaranteed and not subject to production testing.
 4. Bit Time (BT) is the duration of one bit as transferred to/from the MAC and is the reciprocal of bit rate. BT for 10BASE-T = 10⁻⁷ s or 100 ns.

Figure 39 10 Mbps IRB-to-TP Port Timing

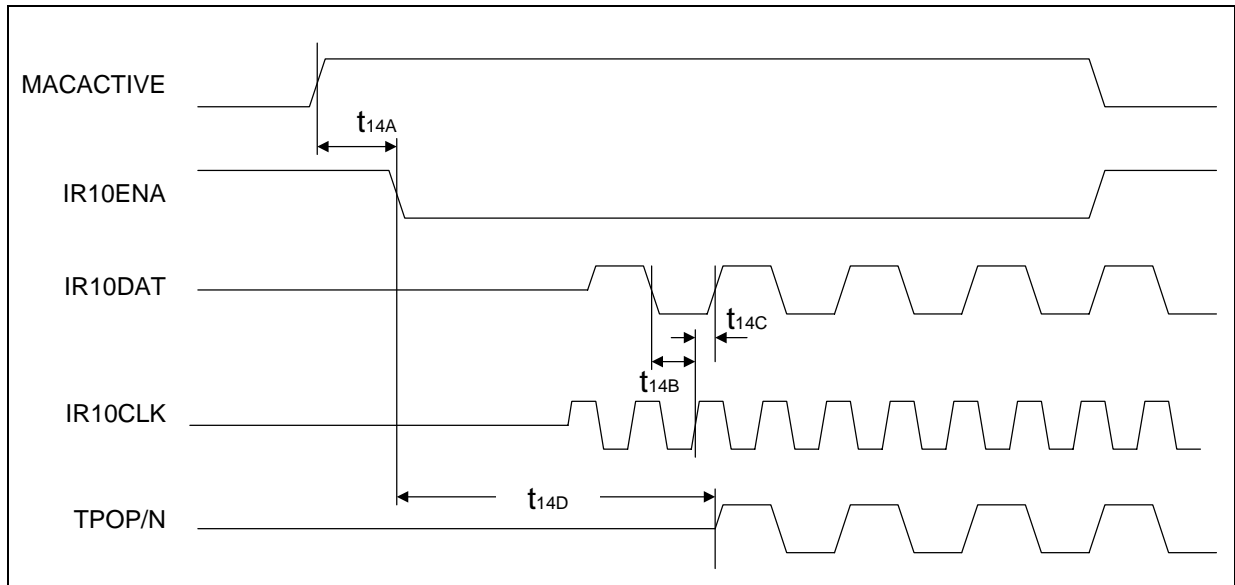

Table 42 10 Mbps IRB-to-TP Port Timing Parameters

Parameter	Sym	Min	Typ ¹	Max	Units ²	Test Conditions
MACACTIVE to $\overline{\text{IR10ENA}}$ assertion delay ³	t14A	–	100	–	ns	MACACTIVE High to $\overline{\text{IR10ENA}}$ Low. ⁴
IR10DAT (input) to IR10CLK setup time	t14B	–	20	–	ns	IR10DAT valid to IR10CLK rising edge. ⁴
IR10CLK to IR10DAT (input) hold time	t14C	–	0	–	ns	IR10CLK rising edge to IR10DAT change. ⁴
$\overline{\text{IR10ENA}}$ asserted to TPOP/N active	t14D	4	5.1	6	BT	–

1. Typical values are at 25° C and are for design aid only; they are not guaranteed and not subject to production testing.
 2. Bit Time (BT) is the duration of one bit as transferred to/from the MAC and is the reciprocal of bit rate. BT for 10BASE-T = 10⁻⁷ s or 100 ns.
 3. External devices should allow at least one 10 MHz clock cycle (10 ns) between assertion of MACACTIVE and $\overline{\text{IR10ENA}}$.
 4. Input.

Figure 40 Serial Management Interface Timing

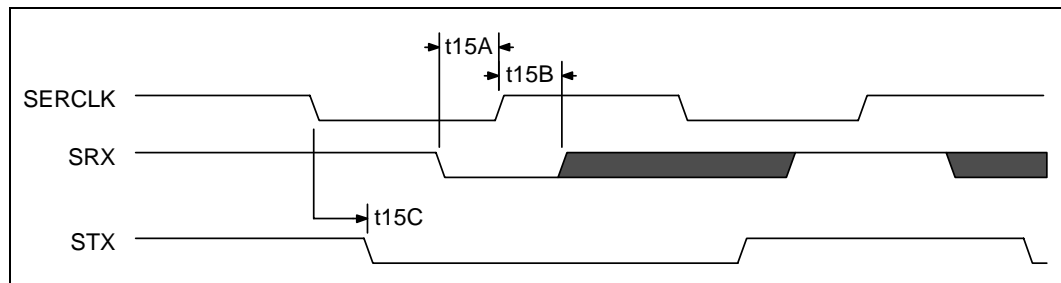

Table 43 Serial Management Interface Timing Characteristics (Sheet 1 of 2)

Parameter	Sym	Min	Typ ¹	Max	Units	Test Conditions
SERCLK input frequency	–	–	–	2.0	MHz	Depending on RECONFIG, this is either an input or output.
SERCLK output frequency	–	–	625	–	kHz	

1. Typical values are at 25° C and are for design aid only; they are not guaranteed and not subject to production testing.
 2. Input.
 3. Output.

Table 43 Serial Management Interface Timing Characteristics (Sheet 2 of 2)

Parameter	Sym	Min	Typ ¹	Max	Units	Test Conditions
Data to clock setup time	t15A	0	–	–	ns	SRX valid to SERCLK rising edge. ²
Clock to data hold time	t15B	200	–	–	ns	SERCLK rising edge to SRX change. ²
Data propagation delay	t15C	–	–	200	ns	SERCLK falling edge to STX valid. ³

1. Typical values are at 25° C and are for design aid only; they are not guaranteed and not subject to production testing.
 2. Input.
 3. Output.

Figure 41 PROM Interface Timing

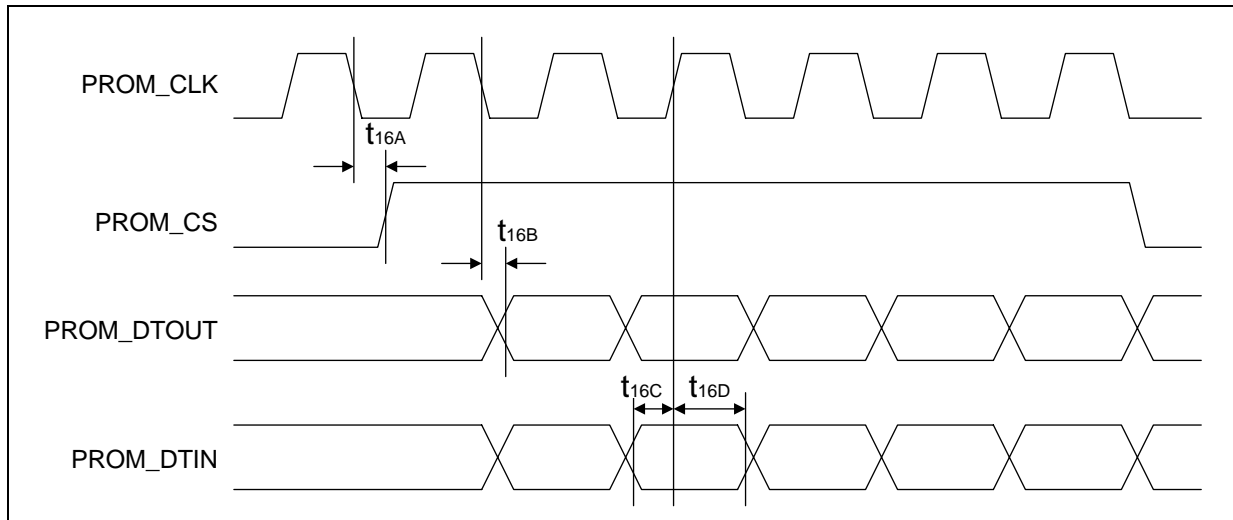

Table 44 PROM Interface Timing Characteristics (Sheet 1 of 2)

Parameter	Sym	Min	Typ ¹	Max	Units	Test Conditions
PROM_CLK	–	–	–	1.0	MHz	PROM_CLK frequency.
CLK to PROM_CS delay	t16A	–	–	200	ns	CLK falling edge to PROM_CS.

1. Typical values are at 25° C and are for design aid only; they are not guaranteed and not subject to production testing.

Table 44 PROM Interface Timing Characteristics (Sheet 2 of 2)

Parameter	Sym	Min	Typ ¹	Max	Units	Test Conditions
CLK to PROM_DTOUT delay	t16B	–		20	ns	CLK falling edge to PROM_DTOUT.
PROM_DTIN to CLK setup time	t16C	20		–	ns	PROM_DTIN to CLK rising edge.
PROM_DTIN to CLK hold time	t16D	20		–	ns	PROM_DTIN to CLK rising edge.
1. Typical values are at 25° C and are for design aid only; they are not guaranteed and not subject to production testing.						

5.0 Register Definitions

5.1 Register Map

The LXT98x0 Repeater register set is composed of multiple 32-bit registers as mapped in [Table 45](#). All register addresses are hexadecimal.

Table 45 Register Map (Sheet 1 of 9)

Class	Register	Size (Bits)	Access ¹	Offset (Hex)	Page Ref.
Port Counters: TP and MII ports formula: $((N-1)*16) + \text{offset}$ N = port number. $0 < N < 11$	rptrMonitorPortReadableFrames	32	R/W	0	page 96
	rptrMonitorPortReadableOctets(Lower/Upper)	64	R/W	1,2	page 96
	rptrMonitorPortFrameCheckSequence	32	R/W	3	page 96
	rptrMonitorPortAlignmentErrors	32	R/W	4	page 96
	rptrMonitorPortFramesTooLong	32	R/W	5	page 96
	rptrMonitorPortShortEvents	32	R/W	6	page 96
	rptrMonitorPortRuns	32	R/W	7	page 96
	rptrMonitorPortCollisions	32	R/W	8	page 96
	rptrMonitorPortLateEvents	32	R/W	9	page 96
	rptrMonitorPortVeryLongEvents	32	R/W	A	page 96
	rptrMonitorPortDataRateMismatches	32	R/W	B	page 96
	rptrMonitorPortAutoPartitions	32	R/W	C	page 96
	rptrTrackSourceAddrChanges	32	R/W	D	page 96
	rptrMonitorPortBroadcastPkts	32	R/W	E	page 96
	rptrMonitorPortMulticastPkts	32	R/W	F	page 96

1. R = Read only; W = Write only; R/W = Read/Write; LH = Latch High; LL = Latch Low; SC = Self Clearing.
 2. If Register Clear bit is set to '1', then clearing of the associated bit is done by writing '1' to it, otherwise this register self clears upon read. Register Clear (Bit 11) is set through the Repeater Configuration Register. (Refer to [Table 75 on page 111](#).)

Table 45 Register Map (Sheet 2 of 9)

Class	Register	Size (Bits)	Access ¹	Offset (Hex)	Page Ref.
Additional Counters: (100 only)	rptrMonitorPortIsolates - port 1	32	R/W	A0	page 96
	rptrMonitorPortIsolates - port 2	32	R/W	A1	page 96
	rptrMonitorPortIsolates - port 3	32	R/W	A2	page 96
	rptrMonitorPortIsolates - port 4	32	R/W	A3	page 96
	rptrMonitorPortIsolates - port 5	32	R/W	A4	page 96
	rptrMonitorPortIsolates - port 6	32	R/W	A5	page 96
	rptrMonitorPortIsolates - port 7	32	R/W	A6	page 96
	rptrMonitorPortIsolates - port 8	32	R/W	A7	page 96
	rptrMonitorPortIsolates-MII Port 1	32	R/W	A8	page 96
	rptrMonitorPortIsolates-MII Port 2	32	R/W	A9	page 96
	rptrMonitorSymbolErrorDuringPacket - port 1	32	R/W	AA	page 97
	rptrMonitorSymbolErrorDuringPacket - port 2	32	R/W	AB	page 97
	rptrMonitorSymbolErrorDuringPacket - port 3	32	R/W	AC	page 97
	rptrMonitorSymbolErrorDuringPacket - port 4	32	R/W	AD	page 97
	rptrMonitorSymbolErrorDuringPacket - port 5	32	R/W	AE	page 97
	rptrMonitorSymbolErrorDuringPacket - port 6	32	R/W	AF	page 97
	rptrMonitorSymbolErrorDuringPacket - port 7	32	R/W	B0	page 97
	rptrMonitorSymbolErrorDuringPacket - port 8	32	R/W	B1	page 97
	Reserved	32	R/W	B2	page 97
	Reserved	32	R/W	B3	page 97

1. R = Read only; W = Write only; R/W = Read/Write; LH = Latch High; LL = Latch Low; SC = Self Clearing.
 2. If Register Clear bit is set to '1', then clearing of the associated bit is done by writing '1' to it, otherwise this register self clears upon read. Register Clear (Bit 11) is set through the Repeater Configuration Register. (Refer to Table 75 on page 111.)

Table 45 Register Map (Sheet 3 of 9)

Class	Register	Size (Bits)	Access ¹	Offset (Hex)	Page Ref.
RMON Counters: (10 only)	etherStatsOctets	32	R/W	B4	page 97
	etherStatsPkts	32	R/W	B5	page 97
	etherStatsBroadcastPkts	32	R/W	B6	page 97
	etherStatsMulticastPkts	32	R/W	B7	page 97
	etherStatsCRCAlignErrors	32	R/W	B8	page 97
	etherStatsUndersizePkts	32	R/W	B9	page 97
	etherStatsOversizePkts	32	R/W	BA	page 97
	etherStatsFragments	32	R/W	BB	page 97
	etherStatsJabbers	32	R/W	BC	page 97
	etherStatsCollisions/ rptrMonitorTransmitCollisions	32	R/W	BD	page 97
	etherStatsPkts64Octets	32	R/W	BE	page 97
	etherStatsPkts65to127Octets	32	R/W	BF	page 97
	etherStatsPkts128to255Octets	32	R/W	C0	page 97
	etherStatsPkts256to511Octets	32	R/W	C1	page 97
	etherStatsPkts512to1023Octets	32	R/W	C2	page 98
	etherStatsPkts1024to1518Octets	32	R/W	C3	page 98
	Reserved	32	R/W	C4	page 98
	rptrMonitorTotalOctets(Lower/Upper)	32	R/W	C5	page 98

1. R = Read only; W = Write only; R/W = Read/Write; LH = Latch High; LL = Latch Low; SC = Self Clearing.
 2. If Register Clear bit is set to '1', then clearing of the associated bit is done by writing '1' to it, otherwise this register self clears upon read. Register Clear (Bit 11) is set through the Repeater Configuration Register. (Refer to Table 75 on page 111.)

Table 45 Register Map (Sheet 4 of 9)

Class	Register	Size (Bits)	Access ¹	Offset (Hex)	Page Ref.
RMON Counters: (100 only)	etherStatsOctets(Lower/Upper)	64	R/W	C6, C7	page 99
	etherStatsPkts	32	R/W	C8	page 99
	etherStatsBroadcastPkts	32	R/W	C9	page 99
	etherStatsMulticastPkts	32	R/W	CA	page 99
	etherStatsCRCAlignErrors	32	R/W	CB	page 99
	etherStatsUndersizePkts	32	R/W	CC	page 99
	etherStatsOversizePkts	32	R/W	CD	page 99
	etherStatsFragments	32	R/W	CE	page 99
	etherStatsJabbers	32	R/W	CF	page 99
	etherStatsCollisions/ rptrMonitorTransmitCollisions	32	R/W	D0	page 99
	etherStatsPkts64Octets	32	R/W	D1	page 99
	etherStatsPkts65to127Octets	32	R/W	D2	page 99
	etherStatsPkts128to255Octets	32	R/W	D3	page 99
	etherStatsPkts256to511Octets	32	R/W	D4	page 99
	etherStatsPkts512to1023Octets	32	R/W	D5	page 99
	etherStatsPkts1024to1518Octets	32	R/W	D6	page 99
	Reserved	32	R	D7	page 99
		rptrMonitorTotalOctets(Lower/Upper)	64	R/W	D8, D9
Port Addresses	rptrAddrTrackNewLastSrcAddress - port 1	48	R/W	DA, DB	page 100
	rptrAddrTrackNewLastSrcAddress - port 2	48	R/W	DC, DD	page 100
	rptrAddrTrackNewLastSrcAddress - port 3	48	R/W	DE, DF	page 100

1. R = Read only; W = Write only; R/W = Read/Write; LH = Latch High; LL = Latch Low; SC = Self Clearing.
 2. If Register Clear bit is set to '1', then clearing of the associated bit is done by writing '1' to it, otherwise this register self clears upon read. Register Clear (Bit 11) is set through the Repeater Configuration Register. (Refer to [Table 75 on page 111](#).)

Table 45 Register Map (Sheet 5 of 9)

Class	Register	Size (Bits)	Access ¹	Offset (Hex)	Page Ref.
	rptrAddrTrackNewLastSrcAddress - port 4	48	R/W	E0, E1	page 100
	rptrAddrTrackNewLastSrcAddress - port 5	48	R/W	E2, E3	page 100
	rptrAddrTrackNewLastSrcAddress - port 6	48	R/W	E4, E5	page 100
	rptrAddrTrackNewLastSrcAddress - port 7	48	R/W	E6, E7	page 100
	rptrAddrTrackNewLastSrcAddress - port 8	48	R/W	E8, E9	page 100
Authorized Addresses	Authorized SA port 1	48	R/W	EE, EF	page 100
	Authorized SA port 2	48	R/W	F0, F1	page 100
	Authorized SA port 3	48	R/W	F2, F3	page 100
	Authorized SA port 4	48	R/W	F4, F5	page 100
	Authorized SA port 5	48	R/W	F6, F7	page 100
	Authorized SA port 6	48	R/W	F8, F9	page 100
	Authorized SA port 7	48	R/W	FA, FB	page 100
	Authorized SA port 8	48	R/W	FC, FD	page 100
Search Addresses (10 or 100)	Search Address	48	R/W	102, 103	page 101
	Search Match Address	10	R(W) ²	104	page 101
Repeater Port Control	Port Link Control Enable	8	R/W	105	page 103
	Port Alternate Partition Algorithm Control	10	R/W	108	page 103
	Port Enable	10	R/W	109	page 103
	Port Learn Enable	20	R/W	10A	page 104
	Reserved		R/W	10B	page 104
Repeater Port Status	Port Link Status	8	R	10C	page 105

1. R = Read only; W = Write only; R/W = Read/Write; LH = Latch High; LL = Latch Low; SC = Self Clearing.
 2. If Register Clear bit is set to '1', then clearing of the associated bit is done by writing '1' to it, otherwise this register self clears upon read. Register Clear (Bit 11) is set through the Repeater Configuration Register. (Refer to [Table 75 on page 111](#).)

Table 45 Register Map (Sheet 6 of 9)

Class	Register	Size (Bits)	Access ¹	Offset (Hex)	Page Ref.
	Port Polarity Status	8	R	10D	page 105
	Port Partition Status	10	R	10E	page 105
	Port Speed Status	10	R	110	page 105
	Port Isolation Status (TX)	10	R	111	page 105
PHY Port Status	Auto Negotiate Link Partner Advertisement (port 1)	16	R	112	page 106
	Auto Negotiate Link Partner Advertisement (port 2)	16	R	113	page 106
	Auto Negotiate Link Partner Advertisement (port 3)	16	R	114	page 106
	Auto Negotiate Link Partner Advertisement (port 4)	16	R	115	page 106
	Auto Negotiate Link Partner Advertisement (port 5)	16	R	116	page 106
	Auto Negotiate Link Partner Advertisement (port 6)	16	R	117	page 106
	Auto Negotiate Link Partner Advertisement (port 7)	16	R	118	page 106
	Auto Negotiate Link Partner Advertisement (port 8)	16	R	119	page 106
	Auto Negotiate Expansion (port 1)	16	R	11A	page 107
	Auto Negotiate Expansion (port 2)	16	R	11B	page 107
	Auto Negotiate Expansion (port 3)	16	R	11C	page 107
	Auto Negotiate Expansion (port 4)	16	R	11D	page 107
	Auto Negotiate Expansion (port 5)	16	R	11E	page 107
	Auto Negotiate Expansion (port 6)	16	R	11F	page 107
	Auto Negotiate Expansion (port 7)	16	R	120	page 107
	Auto Negotiate Expansion (port 8)	16	R	121	page 107
	PHY Port Status Register (port 1)	16	R/W	122	page 107

1. R = Read only; W = Write only; R/W = Read/Write; LH = Latch High; LL = Latch Low; SC = Self Clearing.
 2. If Register Clear bit is set to '1', then clearing of the associated bit is done by writing '1' to it, otherwise this register self clears upon read. Register Clear (Bit 11) is set through the Repeater Configuration Register. (Refer to Table 75 on page 111.)

Table 45 Register Map (Sheet 7 of 9)

Class	Register	Size (Bits)	Access ¹	Offset (Hex)	Page Ref.
	PHY Port Status Register (port 2)	16	R/W	123	page 107
	PHY Port Status Register (port 3)	16	R/W	124	page 107
	PHY Port Status Register (port 4)	16	R/W	125	page 107
	PHY Port Status Register (port 5)	16	R/W	126	page 107
	PHY Port Status Register (port 6)	16	R/W	127	page 107
	PHY Port Status Register (port 7)	16	R/W	128	page 107
	PHY Port Status Register (port 8)	16	R/W	129	page 107

1. R = Read only; W = Write only; R/W = Read/Write; LH = Latch High; LL = Latch Low; SC = Self Clearing.
 2. If Register Clear bit is set to '1', then clearing of the associated bit is done by writing '1' to it, otherwise this register self clears upon read. Register Clear (Bit 11) is set through the Repeater Configuration Register. (Refer to [Table 75 on page 111.](#))

Table 45 Register Map (Sheet 8 of 9)

Class	Register	Size (Bits)	Access ¹	Offset (Hex)	Page Ref.
PHY Port Control	Auto Negotiate Advertise (ports 1)	16	R/W	12A	page 109
	Auto Negotiate Advertise (ports 2)	16	R/W	12B	page 109
	Auto Negotiate Advertise (ports 3)	16	R/W	12C	page 109
	Auto Negotiate Advertise (ports 4)	16	R/W	12D	page 109
	Auto Negotiate Advertise (ports 5)	16	R/W	12E	page 109
	Auto Negotiate Advertise (ports 6)	16	R/W	12F	page 109
	Auto Negotiate Advertise (ports 7)	16	R/W	130	page 109
	Auto Negotiate Advertise (ports 8)	16	R/W	131	page 109
	PHY Port Control Register (port 1)	16	R/W	132	page 109
	PHY Port Control Register (port 2)	16	R/W	133	page 109
	PHY Port Control Register (port 3)	16	R/W	134	page 109
	PHY Port Control Register (port 4)	16	R/W	135	page 109
	PHY Port Control Register (port 5)	16	R/W	136	page 109
	PHY Port Control Register (port 6)	16	R/W	137	page 109
	PHY Port Control Register (port 7)	16	R/W	138	page 109
	PHY Port Control Register (port 8)	16	R/W	139	page 109

1. R = Read only; W = Write only; R/W = Read/Write; LH = Latch High; LL = Latch Low; SC = Self Clearing.
 2. If Register Clear bit is set to '1', then clearing of the associated bit is done by writing '1' to it, otherwise this register self clears upon read. Register Clear (Bit 11) is set through the Repeater Configuration Register. (Refer to Table 75 on page 111.)

Table 45 Register Map (Sheet 9 of 9)

Class	Register	Size (Bits)	Access ¹	Offset (Hex)	Page Ref.
Repeater Port Control/ Status	Repeater Configuration	32	R/W	13A	page 110
	Repeater Serial Configuration	8	R	13B	page 110
	Device/Rev ID	32	R	13C	page 110
	Reserved	32	R	13D	page 110
	Reserved	32	R	13E	page 110
	Reserved	32	R	13F	page 110
	Global LED Control Register	6	R/W	140	page 110
	Port LED Control Register	20	R/W	141	page 110
	LED Timer Control Register	16	R/W	142	page 110
	MII Status	2	R	143	page 105
	Repeater Reset	1	W	144	page 110
	Software Reset	1	W	145	page 111
	Interrupt Status	16	R(W) ²	146	page 115
Interrupt Mask	16	R/W	147	page 115	
Serial Controller	Assign Address	32	W	188, 189	page 110
	PROM Address	32	R	190, 191	page 110

1. R = Read only; W = Write only; R/W = Read/Write; LH = Latch High; LL = Latch Low; SC = Self Clearing.
 2. If Register Clear bit is set to '1', then clearing of the associated bit is done by writing '1' to it, otherwise this register self clears upon read. Register Clear (Bit 11) is set through the Repeater Configuration Register. (Refer to Table 75 on page 111.)

5.2 Counter Registers

All counters power up to zero.

When reading a 64-bit counter, read the lower address (lower 32 bits of counter) first, followed by the upper address. The first read causes all 64 bits to be simultaneously latched into an internal holding register. The second read is directed to this holding register. The statistics bit must be set off to write to the counters. A write operation of the counters is non-atomic for the 64 bit counters.

For further definitions refer to RFC 1757 and clause 30 of IEEE 802.3.

The ReadableFrame counter max size threshold can either be 1518 or 1522. All counters expecting a Maximum Transmission Unit (MTU) size of 1518 can be changed to a new value of 1522 by setting the Extended Frame bit (13) in the Repeater Configuration Register.

5.2.1 Port Counter Registers

The Port Counter descriptions in Table 46 are intended to be illustrative. For the exact definition of these counters, refer to the Repeater MIB, RFC 1516. All counters count packets, octets or events that were received at each port. In the descriptions, the length of a packet never includes preamble or framing bits (start of frame, end of frame, dribble bits, etc.), but an “event” does include these items. All Port Counters are Read-Only.

Table 46 Port Counter Registers (Sheet 1 of 2)

Name	Offset Addr ^{1,2}	Description
rpPtrMonitorPortReadableFrames	0X0	Counts valid-length (64 to 1518 bytes), valid-CRC, collision-free packets. Depending on the state of the UnicastFrameCount bit (6) in the Repeater Configuration Register, this counter counts either all packets (UnicastFrameCount = 0) or only Unicast Packets (UnicastFrameCount = 1). See Note 3.
rpPtrMonitorPortReadableOctets (Lower/Upper)	0X1, 0X2	Counts the number of octets in all valid-length (64 to 1518 bytes), valid-CRC, collision-free packets, not including preamble and framing bits. This register is not affected by the UnicastFrameCount bit. See Note 3.
rpPtrMonitorPortFrameCheckSequence	0X3	Counts valid length, collision-free packets that had FCS errors, but were correctly framed (had an integral number of octets). If a framing error occurs, this counter does not increment.
rpPtrMonitorPortAlignmentErrors	0X4	Counts valid length, collision-free packets that had FCS errors and were incorrectly framed (had a non-integral number of octets).
rpPtrMonitorPortFramesTooLong	0X5	Counts packets that had a length greater than 1518 octets.
rpPtrMonitorPortShortEvents	0X6	Counts events \leq 'ShortEventMax'. 10 Mbps: 74-82 bit times. 100 Mbps: 74-84 bit times. See Note 4.
rpPtrMonitorPortRunts	0X7	Counts events $>$ 'ShortEventMax', but $<$ 512 bits. See Note 4.
rpPtrMonitorPortCollisions	0X8	Counts the number of collisions that occurred, not including late collisions.
1. All offset addresses are expressed in hex. 2. Replace "X" in address with specific port to be addressed (offsets 0 through 9 correspond to Ports 1 through 10). 3. The ReadableFrame counter max size threshold can either be 1518 or 1522. All counters expecting a MTU size of 1518 can be changed to a new value of 1522 by setting the Extended Frame bit (13) in the Repeater Configuration Register. 4. For 100 Mbps: the "Short Events" register counts events $<$ 88 bit times; the "Port Runts" register counts events \geq 92. A 4-bit-time differential exists because 100 Mbps operates with nibble boundaries, so data packets \leq 4 bits are counted as 4. 5. A0 - A7 corresponds to Port 1 - Port 8. 6. AA - B1 corresponds to Port 1 - Port 8.		

Table 46 Port Counter Registers (Sheet 2 of 2)

Name	Offset Addr ^{1,2}	Description
rpTrMonitorPortLateEvents	0X9	Counts the number of times a collision is detected after the 'LateEventThreshold' time (480-565 bits). This event is counted here and also in the 'collisions' attribute.
rpTrMonitorPortVeryLongEvents	0XA	Counts the number of times the transmitter is active for greater than the MJLP time.
rpTrMonitorPortDataRateMismatches	0XB	Counts the number of times the frequency or data rate of the incoming signal is detectably different from that of the local transmit frequency.
rpTrMonitorPortAutoPartitions	0XC	Counts the number of times this port has been partitioned from the network.
rpTrTrackSourceAddrChanges	0XD	Counts the number of times the source address has changed.
rpTrMonitorPortBroadcastPkts	0XE	Counts the number of good broadcast packets received by this port.
rpTrMonitorPortMulticastPkts	0XF	Counts the number of good multicast packets received by this port.
rpTrMonitorPortIsolates	0A0-0A7 ⁵	Counts the number of times a port auto isolates. NOTE: When these counters increment, none of the other port counters increment, since the frame never had a valid start.
rpTrMonitorSymbolErrorDuringPacket	0AA-0B1 ⁶	Counts the number of time a packet contained symbol errors. Only one symbol error is counted per packet. On the MII ports this counter is invalid.

1. All offset addresses are expressed in hex.
2. Replace "X" in address with specific port to be addressed (offsets 0 through 9 correspond to Ports 1 through 10).
3. The ReadableFrame counter max size threshold can either be 1518 or 1522. All counters expecting a MTU size of 1518 can be changed to a new value of 1522 by setting the Extended Frame bit (13) in the Repeater Configuration Register.
4. For 100 Mbps: the "Short Events" register counts events < 88 bit times; the "Port Runs" register counts events ≥ 92. A 4-bit-time differential exists because 100 Mbps operates with nibble boundaries, so data packets ≤ 4 bits are counted as 4.
5. A0 - A7 corresponds to Port 1 - Port 8.
6. AA - B1 corresponds to Port 1 - Port 8.

5.2.2 RMON Counter Registers

The interface counter descriptions in [Table 47](#) are intended to be illustrative. For the exact definition of these counters, refer to the RMON MIB, RFC 1757. All counters count events, octets or packets that were received from the interface. Packet length never includes preamble or framing bits (start of frame, end of frame, dribble bits, etc.).

Table 47 RMON Counter Registers - 10 Mbps (Sheet 1 of 2)

Name	Addr	Description
etherStatsOctets	0B4	Counts total umber of data octets including those in bad packets and octets in FCS fields, but does not include preamble or other framing bits.
etherStatsPkts	0B5	Total number of packets received from network, including errored packets.
etherStatsBroadcastPkts	0B6	Total number of good broadcast packets received.

Table 47 RMON Counter Registers - 10 Mbps (Sheet 2 of 2)

Name	Addr	Description
etherStatsMulticastPkts	0B7	Total number of good multicast packets received. This number does not include broadcast packets.
etherStatsCRCAAlignErrors	0B8	Total number of valid-length packets (64 to 1518 bytes inclusive) that did not contain an integral number of octets or had a bad Frame Check Sequence (FCS).
etherStatsUndersizePkts	0B9	Total number of well-formed packets that were smaller than 64 octets (excluding framing bits but including FCS octets).
etherStatsOversizePkts	0BA	Total number of well-formed packets that were longer than 1518 octets (excluding framing bits but including FCS octets).
etherStatsFragments	0BB	Total number of packets received that were not an integral number of octets in length or that had a bad Frame Check Sequence (FCS) or Frame Alignment Error (FAE), and were less than 64 octets in length (excluding framing bits, but including FCS octets). Note: a packet without SFD or 0 length is counted here.
etherStatsJabbers	0BC	Total number of packets received that were longer than 1518 octets (excluding framing bits, but including FCS octets), and were not an integral number of octets in length or had a bad Frame Check Sequence (FCS).
etherStatsCollisions/ rptrMonitor Transmit Collisions	0BD	The best estimate of the total number of collisions on this segment.
etherStatsPkts64Octets	0BE	Total number of packets (including error packets) received that were 64 octets in length (excluding framing bits but including FCS octets).
etherStatsPkts65to127Octets	0BF	Total number of packets (including error packets) received that were between 65 and 127 octets in length inclusive (excluding framing bits but including FCS octets).
etherStatsPkts128to255Octets	0C0	Total number of packets (including error packets) received that were between 128 and 255 octets in length inclusive (excluding framing bits but including FCS octets).
etherStatsPkts256to511Octets	0C1	Total number of packets (including error packets) received that were between 256 and 511 octets in length inclusive (excluding framing bits but including FCS octets).
etherStatsPkts512to1023Octets	0C2	Total number of packets (including error packets) received that were between 512 and 1023 octets in length inclusive (excluding framing bits but including FCS octets).
etherStatsPkts1024to1518Octets	0C3	The total number of packets (including error packets) received that were between 1024 and 1518 octets in length inclusive (excluding framing bits but including FCS octets).
Reserved	0C4	-
rptrMonitorTotalOctets	0C5	Total number of octets contained in valid frames received on this segment.

Table 48 RMON Counter Registers - 100 Mbps

Name	Addr	Description
etherStatsOctets (Lower/Upper)	0C6 0C7	Counts total umber of data octets including those in bad packets and octets in FCS fields, but does not include preamble or other framing bits.
etherStatsPkts	0C8	Total number of packets received from network, including errored packets.
etherStatsBroadcastPkts	0C9	Total number of good broadcast packets received.
etherStatsMulticastPkts	0CA	Total number of good multicast packets received. This number does not include broadcast packets.
etherStatsCRCAAlignErrors	0CB	Total number of valid-length packets (64 to 1518 bytes inclusive) that did not contain an integral number of octets or had a bad Frame Check Sequence (FCS).
etherStatsUndersizePkts	0CC	Total number of well-formed packets that were smaller than 64 octets (excluding framing bits but including FCS octets).
etherStatsOversizePkts	0CD	Total number of well-formed packets that were longer than 1518 octets (excluding framing bits but including FCS octets).
etherStatsFragments	0CE	Total number of packets received that were not an integral number of octets in length or that had a bad Frame Check Sequence (FCS) or Frame Alignment Error(FAE), and were less than 64 octets in length (excluding framing bits, but including FCS octets). Note: A packet without SFD or 0 length is counted here.
etherStatsJabbers	0CF	Total number of packets received that were longer than 1518 octets (excluding framing bits, but including FCS octets), and were not an integral number of octets in length or had a bad Frame Check Sequence (FCS).
etherStatsCollisions/ rptrMonitor Transmit Collisions	0D0	The best estimate of the total number of collisions on this segment.
etherStatsPkts64Octets	0D1	Total number of packets (including error packets) received that were 64 octets in length (excluding framing bits but including FCS octets).
etherStatsPkts65to127Octets	0D2	Total number of packets (including error packets) received that were between 65 and 127 octets in length inclusive (excluding framing bits but including FCS octets).
etherStatsPkts128to255Octets	0D3	Total number of packets (including error packets) received that were between 128 and 255 octets in length inclusive (excluding framing bits but including FCS octets).
etherStatsPkts256to511Octets	0D4	Total number of packets (including error packets) received that were between 256 and 511 octets in length inclusive (excluding framing bits but including FCS octets).
etherStatsPkts512to1023Octets	0D5	Total number of packets (including error packets) received that were between 512 and 1023 octets in length inclusive (excluding framing bits but including FCS octets).
etherStatsPkts1024to1518Octets	0D6	The total number of packets (including error packets) received that were between 1024 and 1518 octets in length inclusive (excluding framing bits but including FCS octets).
Reserved	0D7	-
rptrMonitorTotalOctets (Lower/Upper)	0D8, 0D9	Total number of octets contained in valid frames received on this segment.

5.3 Ethernet Address Registers

All Ethernet address registers consist of two 32-bit registers that together contain a 48-bit Ethernet address. Address values are unknown on power up.

Table 49 Ethernet Address Register Bit Assignments

Upper Address	Bits 31:16 Reserved. Bits 15:0 contain bits 47:32 of the Ethernet Address.
Lower Address	Bits 31:0 contain bits 31:0 of the Ethernet Address.

5.3.1 Port Address Registers

The port address register set is described in [Table 50](#). The tracking registers continuously monitor the source addresses of packets emanating from the corresponding ports. The authorized address registers can be used for security functions.

Table 50 Port Address Tracking Registers

Name	Type ¹	Port	Addr ²	Description
rptrAddrTrackNewLastSrcAddress	RW	1	0DA, 0DB	Stores the value of the last Source Address received. Attribute is 6 bytes long. Can also act as NewLastSourceAddress via SW. These addresses power up unknown, but can be zeroed by software. Example Address: 00-20-7B-03-02-01 First Read: ms _b 037B2000 _{lsb} . Second Read: ms _b XXXX0102 _{lsb} All addresses or address pairs must read in order. Only the first read updates the holding register. X's are currently defined as zeros.
		2	0DC, 0DD	
		3	0DE, 0DF	
		4	0E0, 0E1	
		5	0E2, 0E3	
		6	0E4, 0E5	
		7	0E6, 0E7	
		8	0E8, 0E9	
		9	0EA, 0EB	
		10	0EC, 0ED	
authorizedSourceAddress	R/W	1	0EE, 0EF	Used for security address comparisons. An auto learn mode is available. Typically, this address matches: rptrAddrTrackNewLastSrcAddress register. These addresses power up unknown, but can be zeroed by software.
		2	0F0, 0F1	
		3	0F2, 0F3	
		4	0F4, 0F5	
		5	0F6, 0F7	
		6	0F8, 0F9	
		7	0FA, 0FB	
		8	0FC, 0FD	

1. R = Read only; W = Write only; R/W = Read/Write; LH = Latch High; LL = Latch Low; SC = Self Clearing.
 2. All offset addresses are expressed in hex.

5.3.2 Search Address Registers

The LXT98x0 Repeater offers an on-board address search mechanism. Should the user wish to find out if a particular source address has been seen on any of the ports, on any of the segments, this register would be used. Each port within a LXT98x0 Repeater chip is checked for traffic originating from the source address matching the Search Address register. If a match is found, the port number where the traffic originated is saved, thus allowing software to determine where the address is located. The Search Address Match register contains the port from the Search Address match function.

The Search Address and Search Address Match Registers are described in [Table 51](#); bit assignments are provided in [Table 53](#); Search Address Match bit definitions are given in [Table 54](#).

Table 51 Search Address/Search Address Match Register

Name	Type	Addr	Description
Search Address	R/W	102, 103	This register reflects Search Address
Search Match Address		104	This register reflects Search Address Match status

Table 52 Search Address Register Bit Assignments

Upper Address	Bits 31:16 Reserved. Bits 15:0 contain bits 47:32 of the Address.
Lower Address	Bits 31:0 contain bits 31:0 of the Address.

Table 53 Search Match Address Bit Assignments

31:10	9	8	7	6	5	4	3	2	1	0
Rsvd	Port 10 (MII 2)	Port 9 (MII 1)	Port 8	Port 7	Port 6	Port 5	Port 4	Port 3	Port 2	Port 1

Table 54 Search Match Address Bit Definitions (Sheet 1 of 2)

Name	Type ¹	Description	Default
Reserved	R	-	0
Port 10 (MII 2)	R/W	1 = Address in Search Address register matched on this port. 0 = Address did not match Search Address on this port.	0
Port 9 (MII 1)	R/W	1 = Address in Search Address register matched on this port. 0 = Address did not match Search Address on this port.	0
Port 8	R/W	1 = Address in Search Address register matched on this port. 0 = Address did not match Search Address on this port.	0
Port 7	R/W	1 = Address in Search Address register matched on this port. 0 = Address did not match Search Address on this port.	0
Port 6	R/W	1 = Address in Search Address register matched on this port. 0 = Address did not match Search Address on this port.	0
Port 5	R/W	1 = Address in Search Address register matched on this port. 0 = Address did not match Search Address on this port.	0
Port 4	R/W	1 = Address in Search Address register matched on this port. 0 = Address did not match Search Address on this port.	0

Table 54 Search Match Address Bit Definitions (Sheet 2 of 2)

Name	Type ¹	Description	Default
Port 3	R/W	1 = Address in Search Address register matched on this port. 0 = Address did not match Search Address on this port.	0
Port 2	R/W	1 = Address in Search Address register matched on this port. 0 = Address did not match Search Address on this port.	0
Port 1	R/W	1 = Address in Search Address register matched on this port. 0 = Address did not match Search Address on this port.	0

5.4 Repeater Port Control Registers

The Control Register set includes general port control as well as link and learn enable registers.

5.4.1 General Port Control Registers

The General Port Control Register bit assignments are described in [Table 55](#). Refer to [Table 56](#) for the General Port Control Register descriptions.

Table 55 Port Control Register Bit Assignments

31:10	9	8	7	6	5	4	3	2	1	0
Rsvd	Port 10 (MII 2)	Port 9 (MII 1)	Port 8	Port 7	Port 6	Port 5	Port 4	Port 3	Port 2	Port 1

1. Bits 8 and 9 (MII Ports) are not used by the Link Control Register.

Table 56 General Port Control Registers

Name	Type ¹	Addr	Description	Default
Port Alternate Partition Algorithm Control (100 Mbps Only)	R/W	108	Un-partition. The LXT98x0 Repeater twisted-pair ports support two un-partition algorithms: The alternative un-partition algorithm, which complies with IEEE specification 802.3aa, un-partitions a port on <i>either</i> transmit or receive of at least 450-560 bits without collision. ² The normal algorithm, which complies with the IEEE specification 802.3u, is available through the management interface. This algorithm un-partitions a port only when data is transmitted to the port for 450-560 bit times without a collision. Provides per-port selection of partition algorithms. 0 = normal 1 = alternate	1
Port Enable	R/W	109	This register controls whether a port is enabled/disabled. If the MGR_PRES signal is Low on power up, then all ports are disabled until such time that management software re-enables them. Otherwise, the ports are enabled at power-up. 0 = disable 1 = enable	1

1. R = Read only; W = Write only; R/W = Read/Write; LH = Latch High; LL = Latch Low; SC = Self Clearing.
 2. Alternate partition mode also causes port to partition after a single long collision.

5.4.2 Port Link Control Register

The Port Link Control Register bit assignments are described in [Table 57](#). Refer to [Table 58](#) for the Port Link Control Register description.

Table 57 Port Link Control and Status Register Bit Assignments

31:8	7	6	5	4	3	2	1	0
Rsvd	Port 8	Port 7	Port 6	Port 5	Port 4	Port 3	Port 2	Port 1

Table 58 Port Link Control Register

Name	Type ¹	Addr	Description	Default
Port Link Control Enable	R/W	105	This register controls the link function of the twisted-pair ports. 1 = Use Normal Link Control. The port only remains connected to the network so long as link pulses or IDLEs are being received. 0 = Disable Normal Link Control. The port is no longer disconnected due to Link Fail.	1

1. R = Read only; W = Write only; R/W = Read/Write; LH = Latch High; LL = Latch Low; SC = Self Clearing.

5.4.3 Port Learn Enable Register

The Port Learn Enable Register bit assignments are described in [Table 59](#). Refer to [Table 60](#) for the Port Learn Enable Register description.

Table 59 Port Learn Enable Register

31:2 0	19	18	17	16	15	14	13	12	11	10	9	8	7	6	5	4	3	2	1	0
Rsvd	Port 10 (MII 2)	Port 9 (MII 1)	Port 8	Port 7	Port 6	Port 5	Port 4	Port 3	Port 2	Port 1										

Table 60 Port Learn Enable Register

Name	Type	Addr	Description	Default															
Port Learn Enable	R/W	10A	This register sets the level of learning each port uses. The Learn Settings are as follows:	00															
			<table border="1"> <thead> <tr> <th>Bit 1</th> <th>Bit 0</th> <th>Function</th> </tr> </thead> <tbody> <tr> <td>0</td> <td>0</td> <td>Learn each new source addresses.</td> </tr> <tr> <td>0</td> <td>1</td> <td>Next Lock. Learn only the first source address encountered. After a port learns its first address, it changes the Authorized Learn bits (for that port) to a "10" to lock down the address.</td> </tr> <tr> <td>1</td> <td>0</td> <td>Lock. Hardware locked-down the address. Only software can write to this address.</td> </tr> <tr> <td>1</td> <td>1</td> <td>Reserved.</td> </tr> </tbody> </table>		Bit 1	Bit 0	Function	0	0	Learn each new source addresses.	0	1	Next Lock. Learn only the first source address encountered. After a port learns its first address, it changes the Authorized Learn bits (for that port) to a "10" to lock down the address.	1	0	Lock. Hardware locked-down the address. Only software can write to this address.	1	1	Reserved.
			Bit 1		Bit 0	Function													
			0		0	Learn each new source addresses.													
			0		1	Next Lock. Learn only the first source address encountered. After a port learns its first address, it changes the Authorized Learn bits (for that port) to a "10" to lock down the address.													
1	0	Lock. Hardware locked-down the address. Only software can write to this address.																	
1	1	Reserved.																	

5.5 Repeater Port Status Registers

The Port Status Register bit assignments are described in [Table 61](#). Refer to [Table 62](#) for the Port Status Register descriptions.

Table 61 Port Status Register Bit Assignments

31:10	9	8	7	6	5	4	3	2	1	0
Rsvd	Port 10 (MII 2)	Port 9 (MII 1)	Port 8	Port 7	Port 6	Port 5	Port 4	Port 3	Port 2	Port 1
1. Not all Status Registers use bits 8 and 9.										

Table 62 Port Status Registers

Name	Description	Type ¹	Addr	Default
Port Link Status ²	Reflects the current link status of each twisted-pair port. 1 = Link Up. 0 = Link Down.	R	10C	0
Port Polarity Status ²	Reflects the current polarity status of each twisted-pair port. 1 = Polarity Reversed. 0 = Polarity Normal.	R	10D	0
Port Partition Status	Reflects the current partition status of each twisted-pair port. 1 = Port is Partitioned. 0 = Port is Not Partitioned.	R	10E	0
Port Speed Status	Indicates the current speed status of each port. 1 = Port is connected at 100 Mbps. 0 = port is connected at 10 Mbps.	R	110	0
Port Isolation Status	Indicates the current isolation status of each twisted-pair port. 1 = Port is Isolated. 0 = Port is Not Isolated.	R	111	0
PHY Port Status (Summary)	Individual per-port status registers. Refer to Table 68 on page 107 for addressing and other details.	R/W	-	

1. R = Read Only
 2. Register does not track MII port status. Bits 8 and 9 reserved.

Table 63 MII Speed Status Bit Assignments

31:10	9	8	7	6	5	4	3	2	1	0
Rsvd	Rsvd	Rsvd	Rsvd	Rsvd	Rsvd	Rsvd	Rsvd	Rsvd	MII 2	MII 1

Table 64 MII Status Bit Definitions

Name	Description	Type ¹	Addr	Default
MIISpeed Status	Individual MII port speed status registers. 1 = 100 Mbps 0 = 10 Mbps	R	143	LOR

1. R = Read only; W = Write only, R/W = Read/Write, LOR = Latch on Reset, LL = Latch Low, SC = Self Clearing

5.6 PHY Port Status Registers

The port auto-negotiation registers are described in [Table 65](#) through [Table 71](#).

Table 65 Auto-Negotiation Registers

Name	Size Bits	Addr	Type	Description
Auto-Negotiate Link Partner Advertisement #1 (Port 1)	32	112	R	See Table 66 on page 106.
Auto-Negotiate Link Partner Advertisement #1 (Port 2)	32	113	R	
Auto-Negotiate Link Partner Advertisement #1 (Port 3)	32	114	R	
Auto-Negotiate Link Partner Advertisement #1 (Port 4)	32	115	R	
Auto-Negotiate Link Partner Advertisement #1 (Port 5)	32	116	R	
Auto-Negotiate Link Partner Advertisement #1 (Port 6)	32	117	R	
Auto-Negotiate Link Partner Advertisement #1 (Port 7)	32	118	R	
Auto-Negotiate Link Partner Advertisement #1 (Port 8)	32	119	R	
Auto-Negotiate Expansion #1 (Port 1)	32	11A	R	See Table 67 on page 107.
Auto-Negotiate Expansion #1 (Port 2)	32	11B	R	
Auto-Negotiate Expansion #1 (Port 3)	32	11C	R	
Auto-Negotiate Expansion #1 (Port 4)	32	11D	R	
Auto-Negotiate Expansion #1 (Port 5)	32	11E	R	
Auto-Negotiate Expansion #1 (Port 6)	32	11F	R	
Auto-Negotiate Expansion #1 (Port 7)	32	120	R	
Auto-Negotiate Expansion #1 (Port 8)	32	121	R	

Table 66 Auto-Negotiate Link Partner Advertisement Bit Definitions (Sheet 1 of 2)

Bit	Name	Description	Type ¹	Default
31:16	Reserved	Reserved.	R	0
15	Next Page	1 = Link partner has ability to send multi pages. 0 = Link partner has no ability to send multi pages.	R	0
14	Reserved	Reserved.	R	0
13	Remote Fault	1 = Remote fault. 0 = No remote fault.	R	0
12:10	Reserved	Reserved.	R	0
9	100BASE-T4	1 = Link partner is 100BASE-T4 compatible. 0 = Link partner is not 100BASE-T4 compatible.	R	0
8	100BASE-TX FD	1 = Link partner is 100BASE-TX FD capable. 0 = Link partner is not 100BASE-TX FD capable.	R	0

1. R = Read only; W = Write only, R/W = Read/Write, LH = Latch High, LL = Latch Low, SC = Self Clearing

Table 66 Auto-Negotiate Link Partner Advertisement Bit Definitions (Sheet 2 of 2)

Bit	Name	Description	Type ¹	Default
7	100BASE-TX	1 = Link partner is 100BASE-TX capable. 0 = Link partner is not 100BASE-TX capable.	R	0
6	10BASE-T FD	1 = Link partner is 10BASE-T FD capable. 0 = Link partner is not 10BASE-T FD capable.	R	0
5	10BASE-T	1 = Link partner is 10BASE-T capable. 0 = Link partner is not 10BASE-T capable.	R	0
4:0	Selector Field	IEEE 802.3	R	00000

1. R = Read only; W = Write only, R/W = Read/Write, LH = Latch High, LL = Latch Low, SC = Self Clearing

Table 67 Auto-Negotiate Expansion Bit Definitions

Bit	Name	Description	Type ¹	Default
31.5	Reserved	Reserved.	R	0
4	Parallel Detection Fault	1 = More than one of the PMAs detects a valid link. 0 = No conflict.	R/LH	0
3	Link Partner Next Page Able	1 = Link partner is next page able. 0 = Link partner is not next page able.	R	0
2	Next Page Able	0 = Local device is not next page able.	R	0
1	Page Received	1 = 3 identical and consecutive link code words are received. 0 = 3 identical and consecutive link code words have not been received.	R/LH	0
0	Link Partner Auto Negotiate Able	1 = Link partner is auto negotiate able. 0 = Link partner is not auto negotiate able.	R/LH	0

1. R = Read only; W = Write only, R/W = Read/Write, LH = Latch High, LL = Latch Low, SC = Self Clearing

Table 68 PHY Port Status Register Summary

Name	Size	Addr	Type	Description
Port 1	32	122	R	Per port register indicating current status of operating conditions.
Port 2	32	123	R	
Port 3	32	124	R	
Port 4	32	125	R	
Port 5	32	126	R	
Port 6	32	127	R	
Port 7	32	128	R	
Port 8	32	129	R	

Table 69 PHY Port Status Register Bit Definitions

Bit	Name	Description	R/W	Default
31:16	Reserved	Reserved.	R	0
15	100BASE-T4	1 = Port able to perform 100BASE-T4. 0 = Port not able to perform 100BASE-T4.	R	0
14	100BASE-X Full Duplex	1 = Port able to perform full-duplex 100BASE-X. 0 = Port not able to perform full-duplex 100BASE-X.	R	0
13	100BASE-X Half Duplex	1 = Port able to perform half-duplex 100BASE-X. 0 = Port not able to perform half-duplex 100BASE-X.	R	1
12	10 Mbps Full Duplex	1 = Port able to operate at 10 Mbps in full-duplex mode. 0 = Port not able to operate at 10 Mbps full-duplex mode.	R	0
11	10 Mbps Half Duplex	1 = Port able to operate at 10 Mbps in half-duplex mode. 0 = Port not able to operate at 10 Mbps in half-duplex.	R	1
10	100BASE-T2 Full Duplex	1 = Port able to perform full-duplex 100BASE-T2. 0 = Port not able to perform full-duplex 100BASE-T2.	R	0
9	100BASE-T2 Half Duplex	1 = Port able to perform half duplex 100BASE-T2. 0 = Port not able to perform half-duplex 100BASE-T2.	R	0
8	Reserved	Reserved. Tie to ground.	R	0
7	Reserved	Ignore when read.	R	0
6	MF Preamble Suppression	1 = Port accepts management frames with preamble suppressed. 0 = Port does not accept management frames with preamble suppressed.	R	0
5	Auto-Negotiation complete	1 = Auto-Negotiation process completed. 0 = Auto-Negotiation process not completed.	R	0
4	Remote Fault	1 = Remote fault condition detected. 0 = No remote fault condition detected.	R/LH	0
3	Auto-Negotiation Ability	1 = PHY is able to perform Auto-Negotiation. 0 = PHY is not able to perform Auto-Negotiation.	R	1
2	Link Status	1 = Link is up. 0 = Link is down.	R/LL	0
1	Reserved	Reserved. Read as 0.	R	0
0	Reserved	Reserved. Read as 0.	R	0

1. R = Read only; W = Write only, R/W = Read/Write, LH = Latch High, LL = Latch Low, SC = Self Clearing

5.7 PHY Port Control Registers

Table 70 Auto-Negotiation Advertisement Registers

Name	Size Bits	Addr	Type	Description
Auto-Negotiate Advertisement #1 (Port 1)	32	12A	R	See Table 71 on page 109 .
Auto-Negotiate Advertisement #1 (Port 2)	32	12B	R	
Auto-Negotiate Advertisement #1 (Port 3)	32	12C	R	
Auto-Negotiate Advertisement #1 (Port 4)	32	12D	R	
Auto-Negotiate Advertisement #1 (Port 5)	32	12E	R	
Auto-Negotiate Advertisement #1 (Port 6)	32	12F	R	
Auto-Negotiate Advertisement #1 (Port 7)	32	130	R	
Auto-Negotiate Advertisement #1 (Port 8)	32	131	R	

Table 71 Auto Negotiate Advertisement Bit Definitions

Bit	Name	Description	Type ¹	Default
31:16	Reserved	Reserved.	R	0
15	Next Page	1 = Port has ability to send multi pages. 0 = Port has no ability to send multi pages.	R	0
14	Reserved	Reserved.	R	0
13	Remote Fault	1 = Remote fault. 0 = No remote fault.	R/W	0
12:10	Reserved	Reserved.	R	0
9	100BASE-T4	1 = Port is 100BASE-T4 compatible. 0 = Port is not 100BASE-T4 compatible.	R	0
8	100BASE-TX FD	1 = Port is 100BASE-TX Full-Duplex capable. 0 = Port is not 100BASE-TX Full-Duplex capable.	R	0
7	100BASE-TX	1 = Port is 100BASE-TX capable. 0 = Port is not 100BASE-TX capable.	R/W	1
6	10BASE-T FD	1 = Port is 10BASE-T FD capable. 0 = Port is not 10BASE-T FD capable.	R	0
5	10BASE-T	1 = Port is 10BASE-T capable. 0 = Port is not 10BASE-T capable.	R/W	1
4:0	Selector Field	IEEE 802.3.	R	00001

1. R = Read only; W = Write only, R/W = Read/Write., LH = Latch High, LL = Latch Low, SC = Self Clearing

Table 72 PHY Port Control Register

Name	Type ¹	Addr	Description
Port Control Register	R/W	132 - 139	Refer to Table 73 for bit assignments.

1. R = Read only; W = Write only; R/W = Read /Write.

Table 73 PHY Port Control Bit Definitions

Bit	Name	Description	Type ¹	Default
31:16	Reserved	Reserved	R	0
15	Reserved	Write as 0; ignore on read.	R/W	0
14	Loopback	Value is "0" only.	R	0
13	Speed Selection	1 = 100 Mbps. 0 = 10 Mbps.	R/W	0
12	Auto-Negotiation Enable	1 = Enable Auto-Negotiation Process. 0 = Disable Auto-Negotiation Process.	R/W	1
11	Reserved	Write as 0; ignore on read.	R/W	0
10	Reserved	Write as 0; ignore on read.	R/W	0
9	Restart Auto-Negotiation	1 = Restart Auto-Negotiation Process. 0 = Normal operation.	R/W SC	0
8	Duplex Mode	1 = Full-Duplex. 0 = Half-Duplex.	R	0
7	Collision Test	1 = Enable COL signal test. 0 = Disable COL signal test.	R/W	0
6:0	Reserved	Write as 0, ignore on Read.	R/W	0000000

1. R = Read only; W = Write only, R/W = Read/Write, LH = Latch High, LL = Latch Low, SC = Self Clearing

5.8 Repeater Port Control/Status Registers

The Configuration Register set is described in [Table 74](#). Configuration Register definitions and bit assignments are shown in [Table 73](#) through [Table 76](#).

Table 74 Configuration Registers (Sheet 1 of 2)

Name	Type ¹	Addr	Description
Repeater Configuration Register	R/W	13A	Refer to Table 75 for bit assignments.
Repeater Serial Configuration Register	R	13B	This register holds user-defined data. These bits may be used to indicate the type of board configuration, port count or other vendor-related data. Default is set by pins. Refer to Table 76 for bit assignments.
Device/Revision ID register	R	13C	This register follows the IEEE 1149.1 specification. Refer to Table 77 for bit assignments. The upper 4 bits identify the device revision level. The next 16 bits store the Part ID Number. The next 11 bits contain a JEDEC Manufacturer ID, which for Cortina is hexadecimal 'FE'. The lowest bit (0) is set only for the first device in a chain. The encoding scheme used for the Product ID field is implementation dependent.
Reserved	R	13D	-
Reserved	R	13E	-
Reserved	R	13F	-

1. R = Read only; W = Write only; R/W = Read /Write.

Table 74 Configuration Registers (Sheet 2 of 2)

Name	Type ¹	Addr	Description
Global LED Control Register	R/W	140	This register reflects the LED Mode set by hardware pins, and provides software control for the Global Fault LED. Refer to Table 78 .
Port LED Control Register	R/W	141	This register provides a measure of software control over the port LEDs. Refer to Table 80 for bit assignments. During reset, the state of this register is all 1s. If a manager is present, this register remains in the all 1s state after reset. Otherwise, the bits default to hardware control.
LED Timer Control Register	R/W	142	Refer to Section 5.8.5, LED Timer Control Register, on page 114 for details. Bits 15:8 of this register set the slow blink frequency of the LEDs. Bits 7:0 set the fast blink frequency.
Repeater Reset Register	W	144	Writing any data value to this register with the Least Significant Bit (LSB) = 1 causes the repeater logic to reset. (All bits other than LSB do not matter.) The counters and configuration information are held static and is not reset. Refer to Table 82 on page 115 for details.
Software Reset Register	W	145	Writing any data value to this register with the Least Significant Bit (LSB) = 1 is identical to a hardware reset. (All bits other than LSB do not matter.) Refer to Table 83 on page 115 for details.
Assign Address Register (1 and 2)	W	188, 189	Writing a valid 48-bit ID (one that matches the PROM ID) to this register causes the device to change its Hub ID to the contents of the PROM ID register listed below. This register cannot be read. Refer to Table 88 and Table 89, Assign Addr 2, on page 118 for details.
PROM Address Register (1 and 2)	R	190, 191	These two registers contain the 48-bit ID read in from PROM at power-up. Refer to Table 90 and Table 91, PROM Addr 2, on page 118 for details.

1. R = Read only; W = Write only; R/W = Read /Write.

Table 75 Repeater Configuration Register (Sheet 1 of 2)

Bit	Name	Description	Type ¹	Default
31:15	Reserved	Reserved - Write as 0's, ignore on Read	R/W	0
14	Configuration Mode Select	Configuration Mode Select 0 = 2 bit direct input mode (using CONFIG[1:0]) 1 = 8 bit serial bus mode (using CFG_CLK, CFG_DT, CFG_LD)	R/W	0
13	Extended Frame	Extended Frame counting mode 1 = all relevant counters allow max size frames up to 1522 bytes, etherstats counter change from 1518 to 1522 0 = normal mode	R/W	0
12	Enable Port Late Event	Enable Port Late Event 0 = does not allow out of window collisions to increment port Late Event counters. 1 = does allow out of window collisions to increment port Late Event counters.	R/W	0

1. R = Read only; W = Write only, R/W = Read/Write., LH = Latch High, LL = Latch Low, SC = Self Clearing
 2. While the zeroing operation is in progress, the CPU is locked out from accessing the statistics RAM until the "zero counter" bit has been reset back to '0'. This time period is roughly 15 ms.

Table 75 Repeater Configuration Register (Sheet 2 of 2)

Bit	Name	Description	Type ¹	Default
11	Register Clear	Register Clear 0 = clears appropriate registers upon serial read. 1 = requires that appropriate register bits be written to be cleared. (Write a '1' to the bit(s) that are to be cleared.)	R/W	0
10	Statistics Enable	Statistics Enable-Turns statistics gathering on and off.	R/W	1
9	Send /T/R	Send /T/R - Forces a good /T/R after each 100 Mbps transmission	R/W	0
8	Isolate100	Isolate100 - Isolates the IR100CFS stack signal and provides an output pin for disabling an external backplane transceiver	R/W	0
7	Isolate10	Isolate10 - Same as for 100 except also isolates stack IR10COLBP and IR10CFSBP signal.	R/W	0
6	Unicast Frame count	Unicast Frame count 1 = portReadableFrames count only Unicast Frames. 0 = portReadableFrames count all Frames.	R/W	0
5	Arbitration Value	Arbitration Input Value-as read from input pin	R	0
4	Zero Counters	Zero Counters 1 = LXT98x0 Repeater sequentially walks through each counter location and zero its contents. When all counter locations have been cleared, this bit is reset to '0'. ² 0 = normal	R/W	0
3	Enable FIFO error	Enable FIFO error 1 = LXT98x0 Repeater enters transmit collision upon detection of a data rate mismatch. 0 = Normal	R/W	1
2	Reserved	Reserved - Write as '0', ignore on Read.	R/W	0

1. R = Read only; W = Write only, R/W = Read/Write., LH = Latch High, LL = Latch Low, SC = Self Clearing
 2. While the zeroing operation is in progress, the CPU is locked out from accessing the statistics RAM until the "zero counter" bit has been reset back to '0'. This time period is roughly 15 ms.

Table 76 Repeater Serial Configuration

Bit	Name	Description	Type ¹	Default
31:8	Reserved	Reserved.	R	0
7:2	RptrSerConfig	Bits 7:2 of Configuration Interface data. (8-bit mode). Refer to Table 75 , bit 14 description.	R	0
1:0	RptrSerConfig	Bits 1:0 of Configuration Interface data. Refer to Table 75 , bit 14 description.	R	0

1. R = Read only; W = Write only, R/W = Read/Write., LH = Latch High, LL = Latch Low, SC = Self Clearing

5.8.1 Device/Revision Register

The value of this register follows the same scheme as the device identification register found in the IEEE 1149.1 specification. The upper 4 bits correspond to silicon stepping. The next 16 bits store a Part ID Number. The next 11 bits contain a JEDEC Manufacturer ID. Bit zero is '1' if the chip is the first in a stack. The encoding scheme used for the Product ID field is implementation dependent.

Table 77 Device/Revision Register Bit Assignment

31:28	27:12	11:8	7:1	0
Version	Part No.	Jedec Continuation Characters	JEDEC ID ¹	1st in Chain ²
0000	8-port = 0010 0110 1001 1000 6-port = 0010 0110 1000 0100	0000	111 1110	See Note 2
1. The JEDEC ID is an 8-bit identifier. However, the MSB is for parity only and is ignored. Cortina's JEDEC ID is FE (1111 1110) which becomes 111 1110. 2. First Chain Bit = 0 if ChipID ≠ 00. First Chain Bit = 1 if ChipID = 00.				

5.8.2 LED Control Registers

The LED Control Registers and bit assignments are described in [Table 78](#).

5.8.3 LED Global Control Register

This register allows software to have a measure of control over the Global Fault LED; it can read status of LED mode.

If a manager is present the default for the Global Fault LED is 11, else it is 01. Bits (5:4) state what LED mode the chip is in ("00" = mode 1, "01" = mode 2, "10" = mode 3 and "11" = mode 4). These bits are read-only because the LED mode is set only via pins.

When writing this register, all other bits in this register are reserved and may have default = 1 or 0.

Table 78 Global Fault LED Bit Assignments

31:6	5:4	3:2	1:0
Reserved Bit 31:8: Write as 1; Ignore on read Bit 7: Write as 0; Ignore on read Bit 6: Write as 1; Ignore on read	Mode Select	Global Fault	Reserved Write as 0; Ignore on read

5.8.4 Port LED Control Register

This register (refer to [Table 79](#)) is used to encode the measure of control software has over the port LEDs. The LED control encodings are listed in [Table 80](#).

Table 79 LED Configuration (Sheet 1 of 2)

Bit	Name	Description	Type ¹	Default
31:20	Reserved	Reserved	R/W	0s
1. R = Read only; W = Write only, R/W = Read/Write, LH = Latch High, LL = Latch Low, SC = Self Clearing 2. During reset, the state of this register is all 1s. If a manager is present within the system, this register stays in the all 1s state following reset. Otherwise, they default to hardware control (10).				

Table 79 LED Configuration (Sheet 2 of 2)

Bit	Name	Description	Type ¹	Default
19:18	MII2LED	See Table 80 for Bit Definitions.	R/W	10
17:16	MII1LED		R/W	10
15:14	PortLED7		R/W	10
13:12	PortLED6		R/W	10
11:10	PortLED5		R/W	10
9:8	PortLED4		R/W	10
7:6	PortLED3		R/W	10
5:4	PortLED2		R/W	10
3:2	PortLED1		R/W	10
1:0	PortLED0		R/W	10

1. R = Read only; W = Write only, R/W = Read/Write, LH = Latch High, LL = Latch Low, SC = Self Clearing
 2. During reset, the state of this register is all 1s. If a manager is present within the system, this register stays in the all 1s state following reset. Otherwise, they default to hardware control (10).

Table 80 Port LED1, 2, 3 Control Encodings

Port Conf. Bits	Port LED1		Port LED2		Port LED3		
	Modes 1, 3 and 4 Function	Mode 2 Function	Modes 1 and 4 Function	Modes 2 and 3 Function	Modes 1, 3, 4	Mode 2	
00	LED off		LED off	Hardware control	LED Off	LED Off	
01	Reserved	LED fast blink	Reserved		Hardware control	Hardware control	Hardware control
10	Hardware control		Hardware control				
11	LED off	LED on	LED off				

5.8.5 LED Timer Control Register

The upper 8 bits serves as a register for programming the slow blink frequency of the LEDs. The lower 8 bits program the fast LED blink rate. In both registers, the maximum blink frequency is 128 Hz while the minimum frequency is 0.5 Hz.

The slow LED blink rate only applies to LED Mode 2, while the fast LED blink rate is applicable to all LED schemes.

Table 81 LED Timer Control Register Bit Assignments

31:16	15:8	7:0
Reserved	Slow Blink Frequency Default is xCC, 1.6 s	Fast Blink Frequency Default is x32, 0.4 s
Period = 7.8125 ms x (Register Value + 1) Frequency = 1 ÷ 7.8125 ms x (Register Value + 1)		

5.8.6 Repeater Reset Register

Table 82 Repeater Reset

Bit	Name	Description	Type ¹	Default
31:1	Reserved	Reserved.	R	0
0	RPTRRST	Writing a '1' to this bit causes the repeater logic to be reset. Counter and configuration logic does NOT reset.	W	0

1. R = Read only; W = Write only, R/W = Read/Write., LH = Latch High, LL = Latch Low, SC = Self Clearing

5.8.7 Software Reset Register

Table 83 Software Reset

Bit	Name	Description	Type ¹	Default
31:1	Reserved	Reserved.	R	0
0	SWRST	Writing a '1' to this bit causes the chip logic to be reset. Software Reset is the same as a Hardware Reset.	W	0

1. R = Read only; W = Write only, R/W = Read/Write., LH = Latch High, LL = Latch Low, SC = Self Clearing

5.8.8 Interrupt Registers

Table 84 Interrupt Status/Mask Register

Name	Type	Addr	Description
Interrupt Status Register	R/W	146	This register captures status bits within the LXT98x0 Repeater and holds them.
Interrupt Mask Register	R/W	147	This register allows masking of individual interrupts.

Table 85 Interrupt Status Register Bit Definitions

Bit	Name	Type ^{1, 2}	Description	Default
31:6	Reserved	R/W	Reserved	0
5	JABINT	R/W	<p>Jabber Interrupt</p> <p>A '1' indicates that a port is in jabber state.</p> <p>During 100 Mbps operation, jabber occurs when any receiver remains active for more than 57,500 bit times. The LXT98x0 Repeater exits this state when all receivers return to the idle condition.</p> <p>During 10 Mbps operation, jabber occurs when any port remains actively transmitting for longer than 40,000 to 75,000 bit times. The LXT98x0 Repeater asserts a minimum-IFG idle period when a port is jabbering.</p>	0
4	ISOLINT	R/W	<p>Isolate Interrupt</p> <p>A '1' indicates that a port has been isolated (100 Mbps only). The LXT98x0 Repeater isolates any port transmitting more than two successive false carrier events. A false carrier event is defined as a packet not starting with a /J/K symbol pair.</p>	0
3	PARTINT	R/W	<p>Partition Interrupt</p> <p>A '1' indicates a port has been partitioned.</p> <p>In 100 Mbps operation, the LXT98x0 Repeater partitions any port participating in excess of 60 consecutive collisions.</p> <p>In 10 Mbps operation, the LXT98x0 Repeater partitions any port participating in excess of 31 consecutive collisions.</p> <p>Once partitioned, the LXT98x0 Repeater continues monitoring and transmitting to the port, but does not repeat data received from the port until it properly un-partitions.</p>	0
2	FCCINT	R/W	<p>False Carrier Count Interrupt</p> <p>A '1' indicates a port has received too many false carrier events.</p>	0
1	SACHNGINT	R/W	<p>Source Address Change Interrupt</p> <p>A '1' indicates that a port address changed from that stored in the last Source Address register.</p>	0
0	SPDCHNGINT	R/W	<p>Speed Change Interrupt</p> <p>A '1' indicates a port speed change was detected.</p>	0
<p>1. R = Read only; W = Write only, R/W = Read/Write., LH = Latch High, LL = Latch Low, SC = Self Clearing</p> <p>2. If Register Clear bit is set to '1', then clearing of the associated bit is done by writing '1' to it, otherwise this register self clears upon read. Register Clear (Bit 11) is set through the Repeater Configuration Register. (Refer to Table 75 on page 111.)</p>				

Table 86 Interrupt Mask Bit Definitions

Bit	Name	Type ¹	Description	Default
31:6	Reserved	R/W	Reserved	0
5	JABMSK	R/W	Jabber Mask Set 0 = do not mask 1 = mask	0
4	ISOLMSK	R/W	Isolate Mask Set 0 = do not mask 1 = mask	0
3	PARTMSK	R/W	Partition Mask Set 0 = do not mask 1 = mask	0
2	FCCMSK	R/W	False Carrier Count Mask Set 0 = do not mask 1 = mask	0
1	SACHNGMSK	R/W	Source Address Change Mask Set 0 = do not mask 1 = mask	0
0	SPDCHNGMSK	R/W	Speed Change Mask Set 0 = do not mask 1 = mask	0

1. R = Read only; W = Write only; R/W = Read/Write., LH = Latch High, LL = Latch Low, SC = Self Clearing.

5.9 Serial Controller Registers

Table 87 Configuration Registers

Name	Type ¹	Addr	Description
Assign Address Register (1 and 2)	W	188, 189	Writing a valid 48-bit ID (one that matches the PROM ID) to this register causes the device to change its Hub ID to the contents of the PROM ID register listed below. This register cannot be read. Refer to Table 88 and Table 89, Assign Addr 2 , on page 118 for details.
PROM Address Register (1 and 2)	R	190, 191	These two registers contain the 48-bit ID read in from PROM at power-up. Refer to Table 90 and Table 91, PROM Addr 2 , on page 118 for details.

1. R = Read only; W = Write only; R/W = Read /Write.

Table 88 Assign Addr 1

Bit	Name	Description	Type ¹	Default
31.0	ASSIGN4716	Bits (47:16) of the PROM serial number	W	0

1. R = Read only; W = Write only; R/W = Read/Write., LH = Latch High, LL = Latch Low, SC = Self Clearing.

Table 89 Assign Addr 2

Bit	Name	Description	Type ¹	Default
31:21	Reserved	Reserved	W	0
20:16	Hub ID	Bits (4:0) of the Hub ID	W	0
15:0	ASSIGN150	Bits (15:0) of the PROM serial number	W	0

1. R = Read only; W = Write only, R/W = Read/Write., LH = Latch High, LL = Latch Low, SC = Self Clearing.

Table 90 PROM Addr 1

Bit	Name	Description	Type ¹	Default
31:0	PROM4716	Bits (47:16) of the PROM serial number	R	0

1. R = Read only; W = Write only, R/W = Read/Write., LH = Latch High, LL = Latch Low, SC = Self Clearing.

Table 91 PROM Addr 2

Bit	Name	Description	Type ¹	Default
31:16	Reserved	Reserved	R	0
15:0	PROM150	Bits (15:0) of the PROM serial number	R	0

1. R = Read only; W = Write only, R/W = Read/Write., LH = Latch High, LL = Latch Low, SC = Self Clearing.

6.0 Mechanical Specifications

Figure 42 Package Specifications for Commercial Temperature

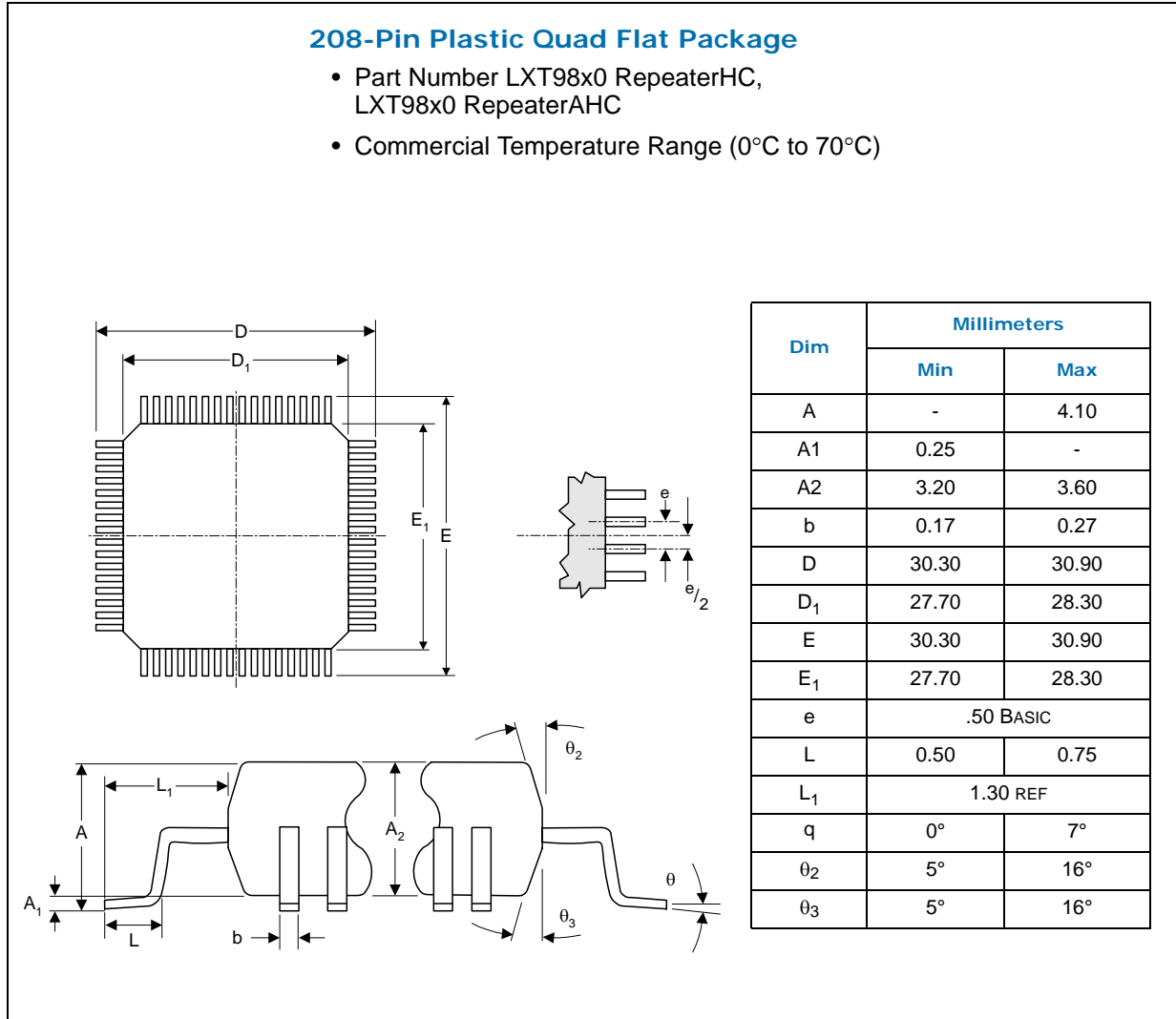
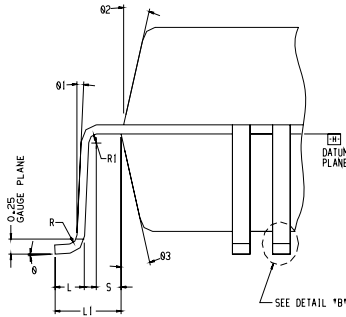

Figure 43 LXT98x0 Repeater Package Specifications for Extended Temperature

208-Pin Plastic Quad Flat Package Heat Slug

- Part Number LXT9880AGE
- Extended Temperature Range (-40°C to +85°C)



DETAIL "A" (20/1)

NOTES:

1. ALL DIMENSIONS AND TOLERANCES CONFORM TO ANSI Y14.5M-1982.
2. DATUMS [A-B] AND [E] TO BE DETERMINED AT DATUM PLANE [H].
3. TO BE DETERMINED AT SEATING PLANE [C].
4. DIMENSIONS DI AND EI DO NOT INCLUDE MOLD PROTRUSION. ALLOWABLE PROTRUSION IS .25MM/.010" PER SIDE. DIMENSIONS DI AND EI ARE MAXIMUM PLASTIC BODY SIZE DIMENSIONS INCLUDING MOLD MISMATCH.
5. CONTROLLING DIMENSION IS MILLIMETER.
6. DIMENSION b DOES NOT INCLUDE DAMBAR PROTRUSION. ALLOWABLE DAMBAR PROTRUSION SHALL BE .08MM/.003" TOTAL IN EXCESS OF THE b DIMENSION AT MAXIMUM MATERIAL CONDITION. DAMBAR CANNOT BE LOCATED ON THE LOWER RADIUS OR THE FOOT.
7. WHEN CONVERTING FROM MILLIMETERS TO INCHES, 4 SIGNIFICANT DIGITS TO THE RIGHT OF THE DECIMAL POINT ARE NECESSARY FOR BOARD LAYOUT PURPOSES.

QFP 208LD

SYM	MILLIMETERS		
	MIN.	NOM.	MAX.
A	-	-	4.10
A1	0.25	-	-
A2	3.20	3.40	3.60
D	30.40	30.60	30.80
DI	27.90	28.00	28.10
D3	-	-	-
E	30.40	30.60	30.80
E1	27.90	28.00	28.10
E3	-	-	-
L	0.50	0.60	0.75
L1	-	1.30 REF	-
N	-	208	-
R	0.08	0.15	0.25
R1	0.08	-	-
S	0.20	-	-
b	0.17	0.22	0.27
b1	0.17	0.20	0.23
c	0.13	-	0.23
c1	0.13	0.152	0.17
e	-	0.50 BSC	-
ccc	-	-	0.08
ddd	-	-	0.08
eee	-	-	0.10
Ø	0°	3.5°	7.0°
Ø1	-	3.0°	-
Ø2	-	7°	-
Ø3	-	7°	-

SYM	INCHES		
	MIN.	NOM.	MAX.
A	-	-	.161
A1	.010	-	-
A2	.126	.134	.142
D	1.197	1.205	1.213
DI	1.098	1.102	1.106
D3	-	-	-
E	1.197	1.205	1.213
E1	1.098	1.102	1.106
E3	-	-	-
L	.020	.024	.030
L1	-	.051 REF	-
N	-	208	-
R	.003	.006	.010
R1	.003	-	-
S	.008	-	-
b	.007	.009	.011
b1	.007	.008	.009
c	.005	-	.009
c1	.005	.006	.007
e	-	.020 BSC	-
ccc	-	-	.003
ddd	-	-	.003
eee	-	-	.004
Ø	0°	3.5°	7.0°
Ø1	-	3.0°	-
Ø2	-	7°	-
Ø3	-	7°	-

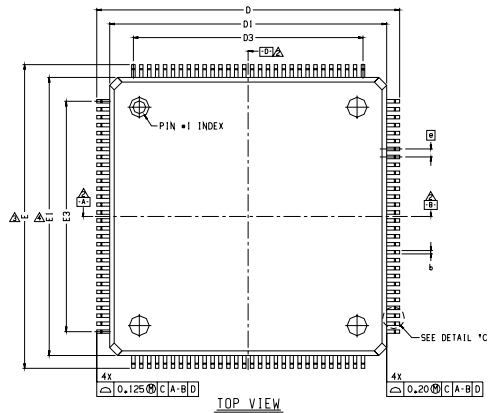

TOP VIEW

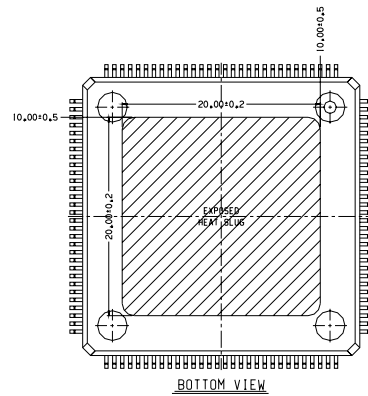

BOTTOM VIEW

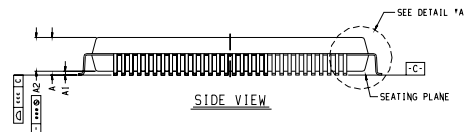

SIDE VIEW

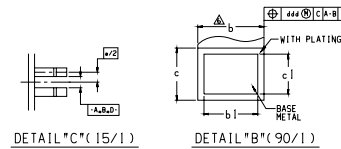

DETAIL "C" (15/1)

DETAIL "B" (90/1)

Contact Information

Cortina Systems, Inc.
840 W. California Ave
Sunnyvale, CA 94086

408-481-2300

sales@cortina-systems.com

apps@cortina-systems.com

www.cortina-systems.com

To provide comments on this document:

documentation@cortina-systems.com