

# Ceramic Trimmer Capacitors



## TZ03 Series

### ■ Features

1. Color coded case facilitates identification of capacitance range.
2. Sealed construction prevents the penetration of flux and dust.
3. Available in three adjustment styles: Top/Rear/Side.
4. Available in both tape and reel and magazine packaging for automatic insertion.
5. + (Cross-shaped) slot enables automatic adjustment.

### ■ Applications

1. Car audio systems
2. Car clocks
3. Stereos
4. Radio cassette tape recorders
5. Cordless telephones
6. Video games
7. Compact radio equipments
8. Remote keyless entry systems
9. Burglarproof devices



B Type

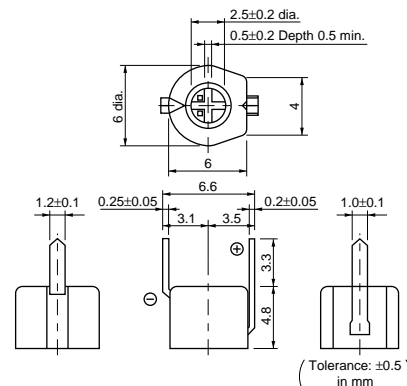

E Type

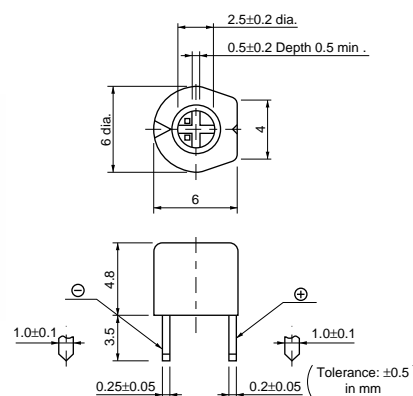

F Type

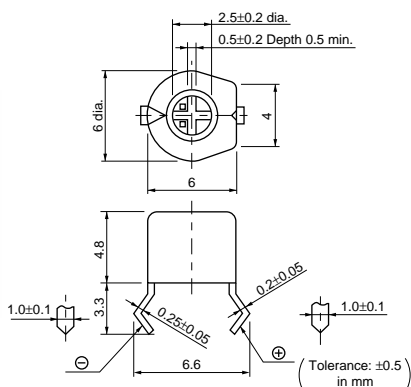

N Type

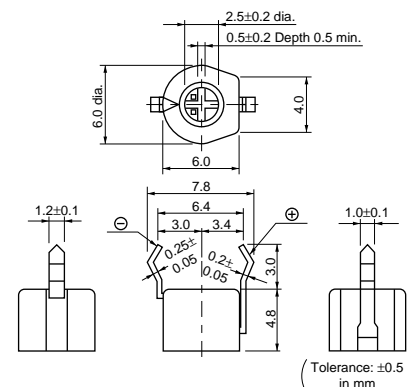

T Type

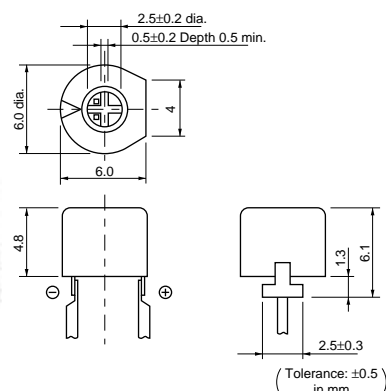

Y Type

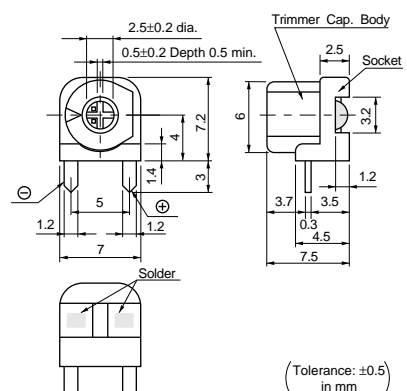

Part Number	Cmin. (max.) (pF)	Cmax. (pF)	TC	Q	Rated Voltage	Withstanding Voltage	Stator/Case Color
TZ03Z2R3□169	1.25	2.3 +50/-0%	NP0±200ppm/°C	300min. at 1MHz, Cmax.	100Vdc	220Vdc	Black
TZ03Z050□169	1.5	5.0 +50/-0%	NP0±200ppm/°C	500min. at 1MHz, Cmax.	100Vdc	220Vdc	Blue
TZ03Z070□169	2.0	7.0 +50/-0%	NP0±200ppm/°C	500min. at 1MHz, Cmax.	100Vdc	220Vdc	Blue
TZ03N100□169	2.1	10.0 +50/-0%	N200±200ppm/°C	500min. at 1MHz, Cmax.	100Vdc	220Vdc	White
TZ03Z100□169	2.7	10.0 +50/-0%	NP0±200ppm/°C	500min. at 1MHz, Cmax.	100Vdc	220Vdc	Blue
TZ03T110□169	3.0	11.0 +50/-0%	N450±300ppm/°C	500min. at 1MHz, Cmax.	100Vdc	220Vdc	White
TZ03R200□169	4.2	20.0 +50/-0%	N750±300ppm/°C	500min. at 1MHz, Cmax.	100Vdc	220Vdc	Red
TZ03T200□169	4.2	20.0 +50/-0%	N450±300ppm/°C	500min. at 1MHz, Cmax.	100Vdc	220Vdc	Pink
TZ03R300□169	5.2	30.0 +50/-0%	N750±300ppm/°C	500min. at 1MHz, Cmax.	100Vdc	220Vdc	Green
TZ03P450□169	6.8	45.0 +50/-0%	N1200±500ppm/°C	300min. at 1MHz, Cmax.	100Vdc	220Vdc	Yellow
TZ03P600□169	9.8	60.0 +50/-0%	N1200±500ppm/°C	300min. at 1MHz, Cmax.	100Vdc	220Vdc	Brown
TZ03Z500□169	6.0	50.0 +100/-0%	NP0±300ppm/°C	300min. at 1MHz, Cmax.	50Vdc	110Vdc	Orange
TZ03R900□169	9.0	90.0 +100/-0%	N750±300ppm/°C	300min. at 1MHz, Cmax.	50Vdc	110Vdc	Black+Dot
TZ03R121□169	10.0	120.0 +100/-0%	N750±300ppm/°C	300min. at 1MHz, Cmax.	50Vdc	110Vdc	Black

Insulation Resistance : 10000M ohm    Torque : 2.0 to 15.0mNm    Operating Temperature Range : -25 to +85°C  
A blank column is filled with terminal type codes.

### Construction

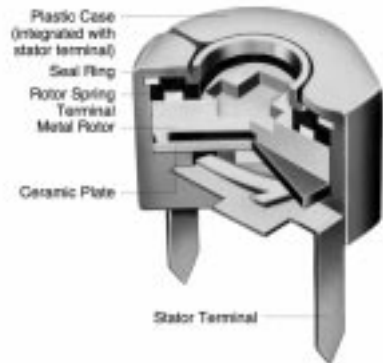

### Mounting Holes

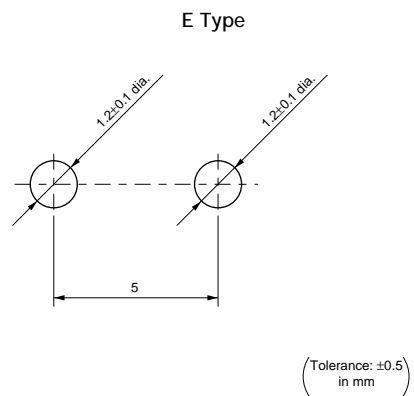
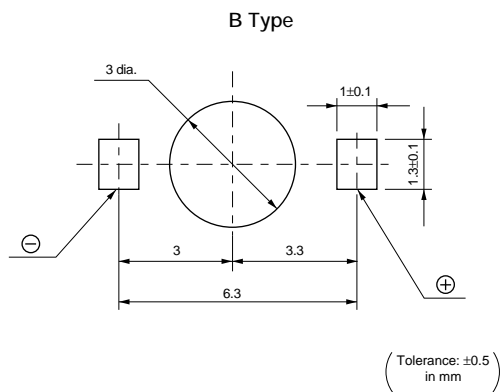

Continued on the following page.

Continued from the preceding page.

## ■ Mounting Holes

F Type

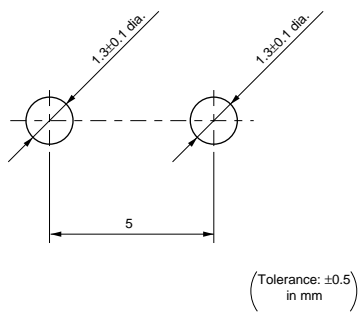

N Type

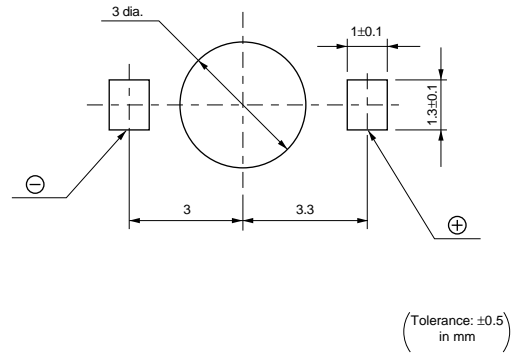

T Type

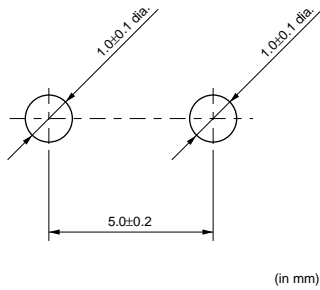

Y Type

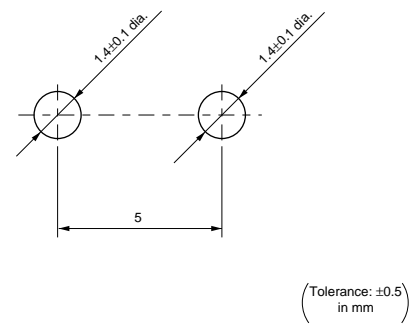

## ■ Temperature Characteristics

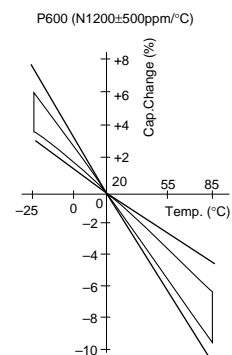
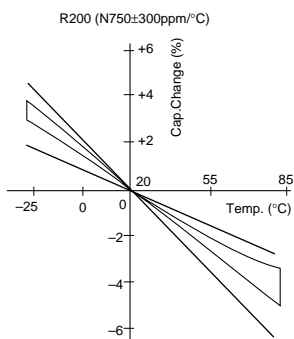
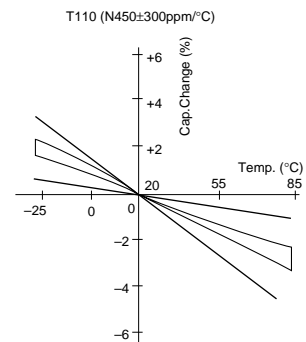
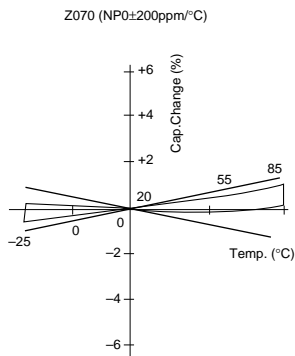

Continued on the following page.

Continued from the preceding page.

## Temperature Characteristics

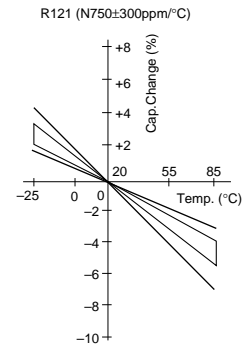
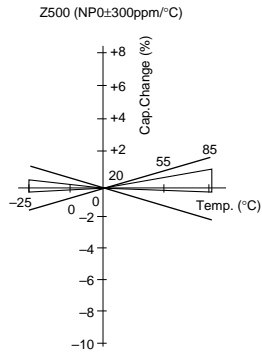

## Frequency Characteristics

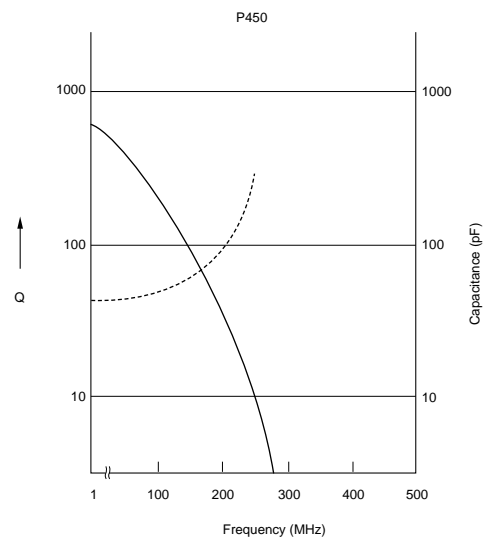
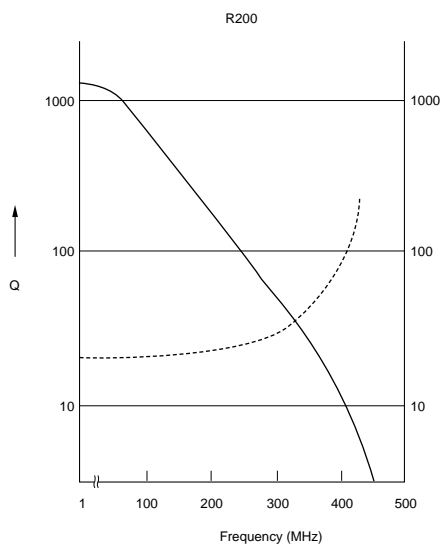
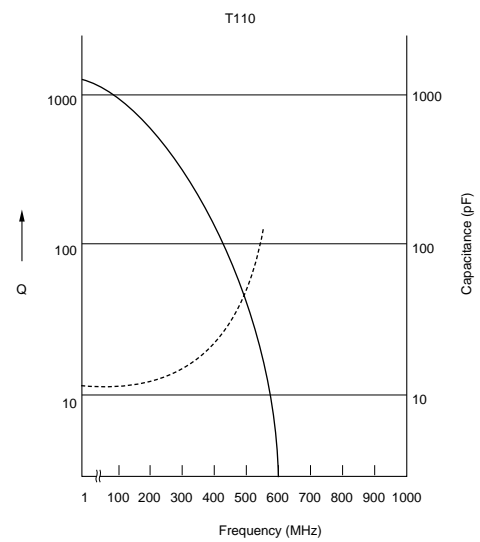
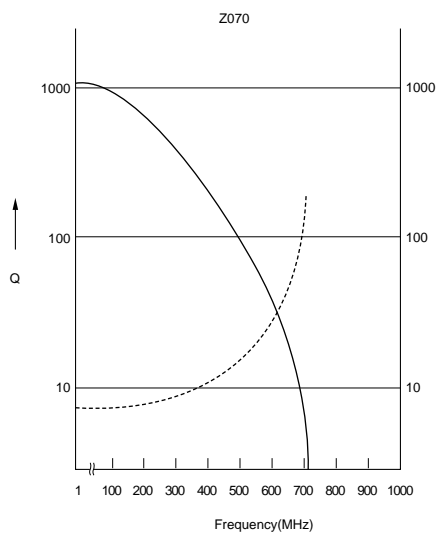

Continued on the following page. ↗

Continued from the preceding page.

## Frequency Characteristics

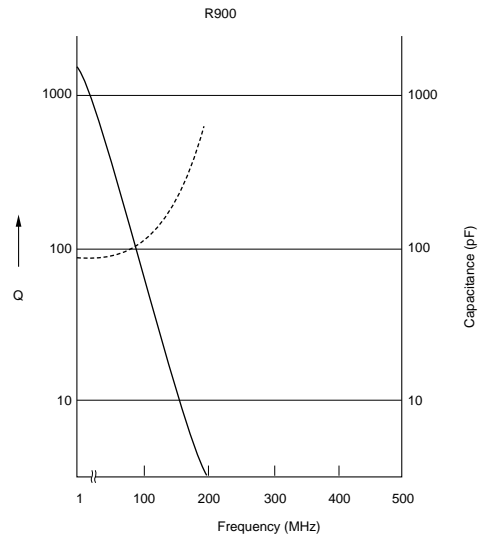
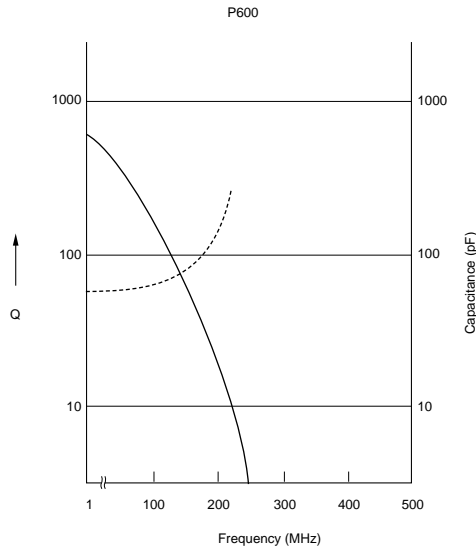

## Temperature Profile

Flow

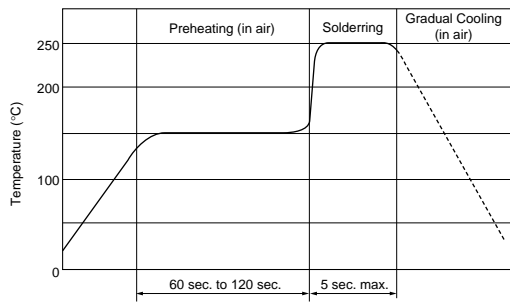

### ■ Notice (Storage and operating condition)

1. Do not use the trimmer capacitor under atmosphere of RTV silicone rubber (Room Temperature Vulcanizing Silicone Rubber) except Acetone liberating silicone sealant.
2. Before using trimmer capacitor, please store under the condition of -10 to +40 degree C and 30 to 85%RH.
3. Do not store in or near corrosive gasses.
4. Use within 6 months of delivery.
5. Open the package just before using.
6. Prior to storing previously opened packages, the packaging should be heat-sealed. Avoid using rubber bands for repackaging.
7. Do not store under direct sunlight.

### ■ Notice (Soldering and mounting)

#### 1. Soldering

- (1) TZ03 series can be soldered by flow soldering method and soldering iron. Do not use reflow soldering method.
- (2) Standard soldering condition
  - (a) Flow soldering: Refer to the standard temperature profile.
  - (b) Soldering iron:
    - > Temperature of tip 260+/-10 degree C
    - > Soldering time 3 sec. max.
    - > Diameter 3mm max.
    - > Wattage of iron 30W max.

Before using other soldering conditions than those listed above, please consult with Murata factory representative prior to using. If the soldering conditions are not suitable, e.g., excessive time and/or excessive temperature, the trimmer capacitor may deviate from the specified characteristics.

- (3) The dimension of mounting hole should be Murata's standard mounting hole used at flow soldering. The amount of solder is critical. Insufficient amounts of solder can lead to insufficient soldering strength on PCB. Excessive amounts of solder may cause bridging between the terminals or contact failure due to flux wicking up.
- (4) When using soldering iron, the string solder shall be applied to the lower part of the terminal only. Do not apply flux except to the terminals. Excessive amounts of solder and/or applying solder to the upper part of the terminal may cause fixed rotor or the contact failure due to flux invasion into the movable part and/or the contact point. The soldering iron should not come in contact with the plastic case of the trimmer capacitor. If such contact does occur, the trimmer capacitor may be damaged.
- (5) Our recommendable chlorine content of string solder is 0.5wt% max.
- (6) Do not use water-soluble flux (for water cleaning). To prevent the deterioration of trimmer

8. Do not use the trimmer capacitor under the conditions listed below.
  - (1) Corrosive gasses atmosphere (ex. Chlorine gas, Hydrogen sulfide gas, Ammonia gas, Sulfuric acid gas, Nitric oxide gas, etc.)
  - (2) In liquid (ex. water, oil, medical liquid, organic solvent, etc.)
  - (3) Dusty / dirty atmosphere
  - (4) Direct sunlight
  - (5) Static voltage nor electric/magnetic fields
  - (6) Direct sea breeze
  - (7) Other variations of the above

capacitor characteristics, apply flux only to terminals.

#### 2. Mounting

- (1) Do not apply excessive force (preferable 5.0N (Ref.; 500gf) max.), when the trimmer capacitor is mounted on the PCB.
- (2) Use the suitable PCB holes which are the same pitch as the terminal of the trimmer capacitor. If it would not fit with the terminal, the excessive stress would be applied to the terminal and the trimmer capacitor may deviate from the specified characteristics.
- (3) Do not apply bending stress more than 10.0N (Ref.; 1kgf) after the trimmer capacitor has been mounted on the PCB.
- (4) Mount trimmer capacitor in contact with PCB.
- (5) In case of bending the terminals, do not apply excessive force to the body of the product and prevent the terminal fixing part from damaging.

#### 3. Cleaning

- (1) Isopropyl alcohol and Ethyl alcohol are available material for cleaning. Water group materials like Pinealpha, Cleanthru cannot be used. For other materials, please consult with Murata factory representative prior to using.
- (2) The total cleaning time by dipping, vapor and ultra-sonic method shall be less than 2 minutes. For ultra-sonic cleaning, the available condition is as follows.
  - > Cleaning time: 30 sec. max.
  - > Power: 20W/liter max.
  - > Frequency: 20 - 60kHz
  - > Temperature: Ambient temperature

Due to the ultra-sonic cleaning equipment's peculiar self resonance point and the cleaning compatibility usually depends on the jig construction and/or the cleaning condition such as the depth of immersion, please check the cleaning equipment to determine the suitable conditions. If the trimmer capacitor is cleaned by other conditions, the trimmer capacitor may

↳ Continued from the preceding page.

deviate from the specified characteristics.

4. Other

Note the polarity of the trimmer capacitor to

minimize influence by stray capacitance.

(Refer to the dimensions concerning the polarity.)

■ Notice (Handling)

1. Use suitable screwdrivers that fit comfortably in driver slot.

(1) Recommended screwdriver for manual adjustment

MURATA: KMDR010

(2) Recommended screwdriver bit for automatic adjustment

MURATA: KMBT010

2. When adjusting with a screwdriver, do not apply

excessive force (preferable 1.0N (Ref: 100gf) max.) to minimize capacitance drift. If excessive force is applied to the screwdriver slot, it may cause deformation of the products.

3. Do not apply adhesive, lock paints, or any other substances to the trimmer capacitor to secure the rotor position. They may cause corrosion or electrical contact problems.

■ Notice (Other)

Before using trimmer capacitor, please test after assembly in your particular mass production system.