

# SP720MD-8, SP720MD, SP720MM-8, SP720MM

High Reliability Electronic Protection Array  
for ESD and Overvoltage Protection

February 1998

## Features

- The SP720MD-8 and SP720MM-8 are Harris Class B "Equivalent" Parts with Back-End Conformance to MIL-STD-883 for Final Assembly, Electrical Testing, Burn-in and QC Inspection
- ESD Interface Capability for HBM Standards
  - Modified MIL STD 3015.7 ..... 15kV
  - MIL STD 3015.7 ..... 6kV
  - IEC 1000-4-2, Direct Discharge,
    - Single Input ..... 4kV (Level 2)
    - Two Inputs in Parallel ..... 8kV (Level 4)
  - IEC 1000-4-2, Air Discharge ..... 15kV (Level 4)
- High Peak Current Capability
  - IEC 1000-4-5 ..... +3A
  - Single Pulse, 100µs Pulse Width ..... ±2A
  - Single Pulse, 4µs Pulse Width ..... ±5A
- Designed to Provide Over-Voltage Protection
  - Single-Ended Voltage Range to ..... +30V
  - Differential Voltage Range to ..... ±15V
- Fast Switching ..... 2ns Risettime
- Low Input Leakages ..... 1nA at 25°C Typical
- Low Input Capacitance ..... 3pF Typical
- An Array of 14 SCR/Diode Pairs
- Military Temperature Range ..... -55°C to 125°C

## Applications

- Microprocessor/Logic Input Protection
- Data Bus Protection
- Analog Device Input Protection
- Voltage Clamp

## Description

The SP720 is a High Reliability Array of SCR/Diode bipolar structures for ESD and over-voltage protection to sensitive input circuits. The SP720 has 2 protection SCR/Diode device structures at each IN input. A total of 14 available IN inputs can be used to protect up to 14 external signal or bus lines. Over voltage protection is from the IN to V+ or V-. The SCR structures are designed for fast triggering at a threshold of one +V<sub>BE</sub> diode threshold above V+ or at a -V<sub>BE</sub> diode threshold below V-. From an IN input, a clamp to V+ is activated if a transient pulse causes the input to be increased to a voltage level greater than one V<sub>BE</sub> above V+. A similar clamp to V- is activated if a negative pulse, one V<sub>BE</sub> less than V-, is applied to an IN input.

The SP720MD-8 and SP720MM-8 Class B "Equivalent" Parts conform to MIL-STD-883 through final assembly, electrical test, burn-in and QC Inspection. The SP720MD and SP720MM are High Reliability Ceramic Packaged ICs.

Refer to Application Note AN9304 for general application information and to AN9612 for further information on ESD and transient rating capabilities of the SP720.

## Ordering Information

PART NO.	TEMP. RANGE (°C)	PACKAGE	PKG. NO.
SP720MD-8	-55 to 125	16 Ld SBDIP	D16.3
SP720MD	-55 to 125	16 Ld SBDIP	D16.3
SP720MM-8	-55 to 125	20 Pad CLCC	J20.A
SP720MM	-55 to 125	20 Pad CLCC	J20.A

## Pinouts

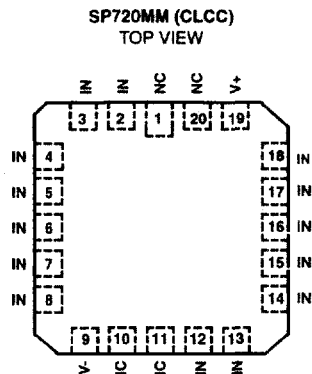
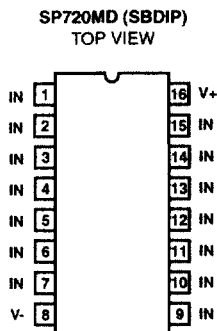

## Functional Block Diagram (SP720MD)

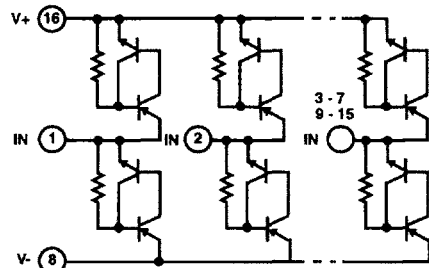

# SP720MD-8, SP720MD, SP720MM-8, SP720MM

## Absolute Maximum Ratings

Continuous Supply Voltage, [(V+) - (V-)] ..... +35V  
 Max. DC Input Current,  $I_{IN}$  .....  $\pm 70$ mA  
 Input Peak Current,  $I_{IN}$  (Refer to Figure 3) .....  $\pm 2$ A, 100 $\mu$ s  
 ESD Capability, Refer to "ESD Capability" and Table 1, Figure 1

## Operating Conditions

Operating Voltage Range, Single Supply ..... +2V to +30V  
 Operating Voltage Range, Split Supply .....  $\pm 1$ V to  $\pm 15$ V  
 Typical Quiescent Supply Current ..... 50nA  
 Operating Temperature Range ..... -55°C to 125°C

**CAUTION:** Stresses above those listed in "Absolute Maximum Ratings" may cause permanent damage to the device. This is a stress only rating and operation of the device at these or any other conditions above those indicated in the operational sections of this specification is not implied.

### NOTE:

- $\theta_{JA}$  is measured with the component mounted on an evaluation PC board in free air.

## Thermal Information

Thermal Resistance (Typical, Note 1)  $\theta_{JA}$  (°C/W)  $\theta_{JC}$  (°C/W)  
 16 Ld SBDIP Package ..... 80 18  
 20 Pad CLCC Package ..... 70 16  
 Maximum Storage Temperature Range ..... -65°C to 150°C  
 Maximum Junction Temperature ..... 175°C  
 Maximum Lead Temperature (Soldering 10s) ..... 265°C

## Electrical Specifications $T_A = -55^\circ\text{C}$ to $125^\circ\text{C}$ , Unless Otherwise Specified

PARAMETER	SYMBOL	TEST CONDITIONS	MIN	TYP	MAX	UNITS
Operating Voltage Range	$V_{SUPPLY}$	$V_{SUPPLY} = [(V+) - (V-)]$	0	2 to 30	35	V
Peak Forward/Reverse Voltage Drop IN to V- (with V- Reference)	$V_{IN} - (V-)$	$I_{IN} = -1$ A (1ms Peak Pulse)	-	-2	-	V
IN to V+ (with V+ Reference)	$V_{IN} - (V+)$	$I_{IN} = +1$ A (1ms Peak Pulse)	-	+2	-	V
DC Forward/Reverse Voltage Drop IN to V- (with V- Reference)	$V_{IN} - (V-)$	$I_{IN} = -100$ mA to V-	-1.5	-	-	V
IN to V+ (with V+ Reference)	$V_{IN} - (V+)$	$I_{IN} = +100$ mA to V+	-	-	+1.5	V
Input Leakage Current	$I_{IN}$	$V^- < V_{IN} < V^+$ , $V_{SUPPLY} = 30$ V	-15	5	+15	nA
Quiescent Supply Current	$I_{QUIESCENT}$	$V^- < V_{IN} < V^+$ , $V_{SUPPLY} = 30$ V	-	50	150	nA
Equivalent SCR ON Threshold		Note 3	-	1.1	-	V
Equivalent SCR ON Resistance		$V_{FWD}/I_{FWD}$ (Note 3)	-	1	-	$\Omega$
Input Capacitance	$C_{IN}$		-	3	-	pF
Input Switching Speed	$t_{ON}$		-	2	-	ns

### NOTES:

- In automotive and battery operated systems, the power supply lines should be externally protected for load dump and reverse battery. When the V+ and V- pins are connected to the same supply voltage source as the device or control line under protection, a current limiting resistor should be connected in series between the external supply and the SP720 supply pins to limit reverse battery current to within the rated maximum limits. Bypass capacitors of typically 0.01 $\mu$ F or larger from the V+ and V- pins to ground are recommended.
- Refer to the Figure 3 graph for definitions of equivalent "SCR ON Threshold" and "SCR ON Resistance". These characteristics are given here for thumb-rule information to determine peak current and dissipation under EOS conditions.

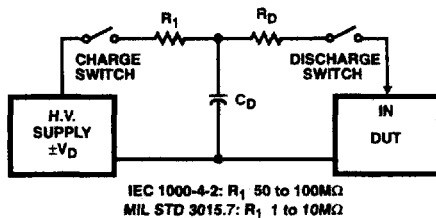

FIGURE 1. ELECTROSTATIC DISCHARGE TEST

TABLE 1. ESD TEST CONDITIONS

STANDARD	TYPE/MODE	$R_D$	$C_D$	$\pm V_D$
MIL STD 3015.7	Modified HBM	1.5k $\Omega$	100pF	15kV
	Standard HBM	1.5k $\Omega$	100pF	6kV
IEC 1000-4-2	HBM, air discharge	330 $\Omega$	150pF	15kV (Level 4)
	HBM, direct discharge	330 $\Omega$	150pF	4kV (Level 2)
	HBM, direct discharge, two parallel input pins	330 $\Omega$	150pF	8kV (Level 4)
EIAJ IC121	Machine Model	0k $\Omega$	200pF	1kV

### ESD Capability

ESD capability is dependent on the application and defined test standard. The evaluation results for various test standards and methods based on Figure 1 are shown in Table 1.

For the "Modified" MIL-STD-3015.7 condition that is defined as an "in-circuit" method of ESD testing, the V+ and V- pins have a return path to ground and the SP720 ESD capability is typically greater than 15kV from 100pF through 1.5kΩ. By strict definition of MIL-STD-3015.7 using "pin-to-pin" device testing, the ESD voltage capability is greater than 6kV. The MIL-STD-3015.7 results were determined from AT&T ESD Test Lab measurements.

The HBM capability to the IEC 1000-4-2 standard is greater than 15kV for air discharge (Level 4) and greater than 4kV for direct discharge (Level 2). Dual pin capability (2 adjacent pins in parallel) is well in excess of 8kV (Level 4).

For ESD testing of the SP720 to EIAJ IC121 Machine Model (MM) standard, the results are typically better than 1kV from 200pF with no series resistance.

### Peak Transient Current Capability

The peak transient current capability rises sharply as the width of the current pulse narrows. Destructive testing was done to fully evaluate the SP720's ability to withstand a wide range of transient current pulses.

The test circuit shown in Figure 2 provides a positive pulse input. For a negative pulse input, the (-) current pulse input goes to an SP720 'IN' input pin and the (+) current pulse input goes to the SP720 V- pin. The V+ to V- supply of the SP720 must be allowed to float. (i.e. It is not tied to the ground reference of the current pulse generator.) Figure 3 shows the point of over-stress as defined by increased leakage in excess of the data sheet published limits.

The maximum peak input current capability is dependent on the V+ to V- voltage supply level, improving as the supply voltage is reduced. Values of 0, 5, 15 and 30 voltages are shown. The safe operating range of the transient peak current should be limited to no more than 75% of the measured over-stress level for any given pulse width as shown in Figure 3.

When adjacent input pins are paralleled, the sustained peak current capability is increased to nearly twice that of a single pin. For comparison, tests were run using dual pin combinations 1+2, 3+4, 5+6, 7+9, 10+11, 12+13 and 14+15. The over-stress curve is shown in Figure 3 for a 15V supply condition. The dual pins are capable of 10A peak current for a 10μs pulse and 4A peak current for a 1ms pulse. The complete curve for single pulse peak current vs. pulse width time ranging up to 1 second is shown in Figure 3.

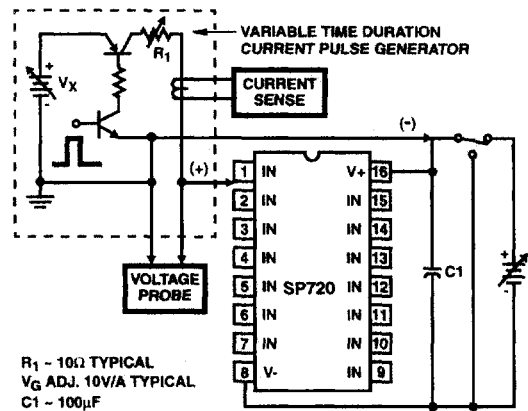

FIGURE 2. TYPICAL SP720 PEAK CURRENT TEST CIRCUIT WITH A VARIABLE PULSE WIDTH INPUT

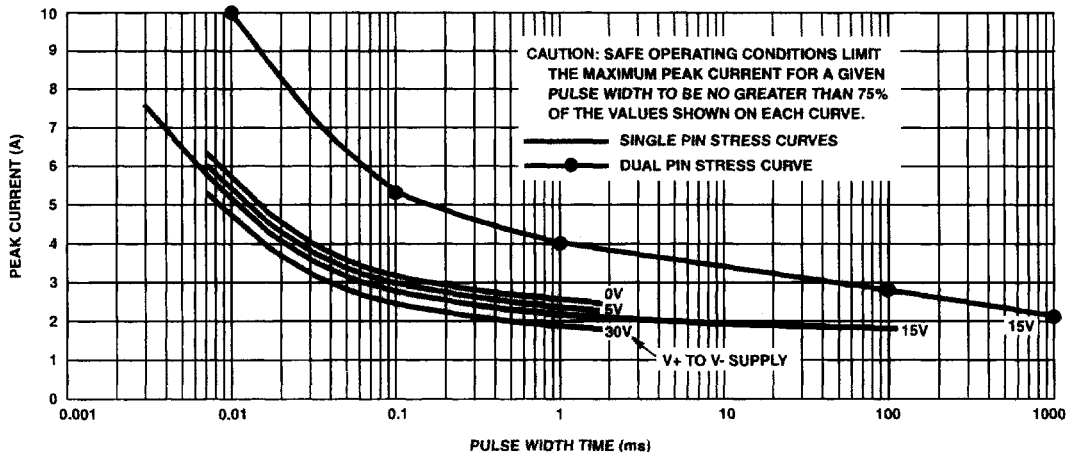

FIGURE 3. TYPICAL SINGLE PULSE PEAK CURRENT CURVES SHOWING THE MEASURED POINT OF OVER-STRESS IN AMPERES vs PULSE WIDTH TIME IN MILLISECONDS, (TA = 25°C)

10  
HIGH RELIABILITY  
SERIES

SP720MD-8, SP720MD, SP720MM-8, SP720MM

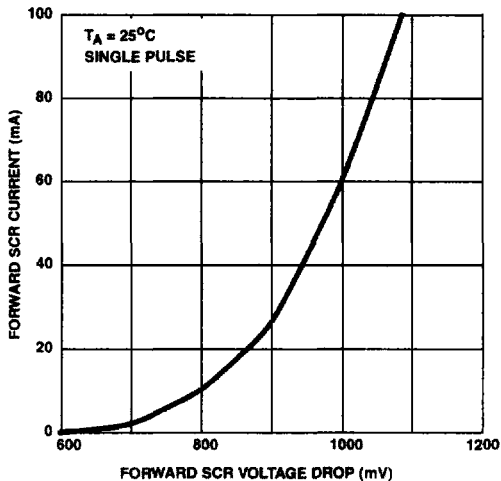

FIGURE 4. LOW CURRENT SCR FORWARD VOLTAGE DROP CURVE

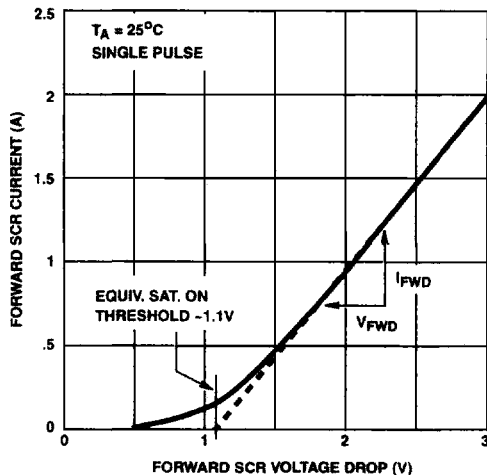

FIGURE 5. HIGH CURRENT SCR FORWARD VOLTAGE DROP CURVE

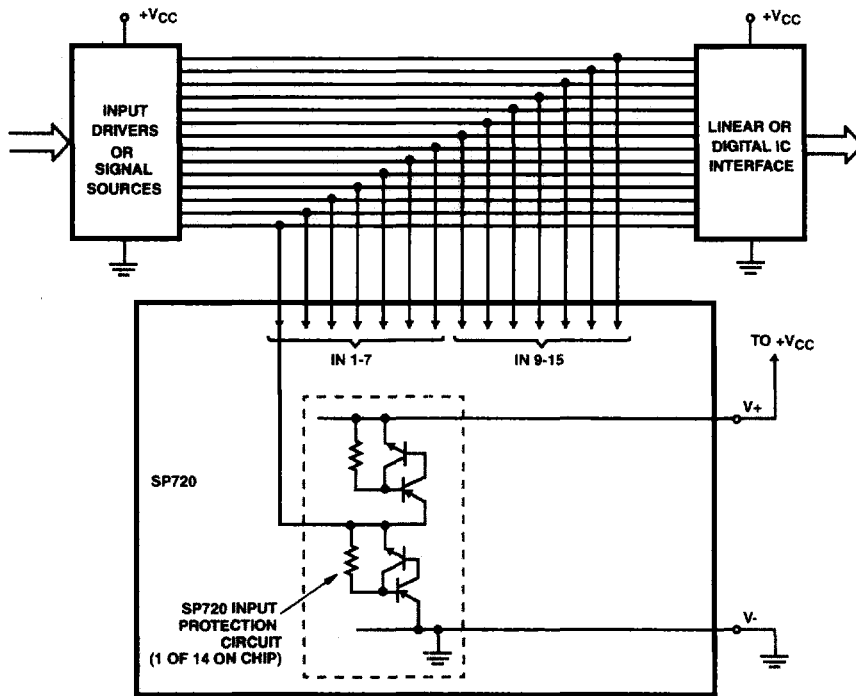
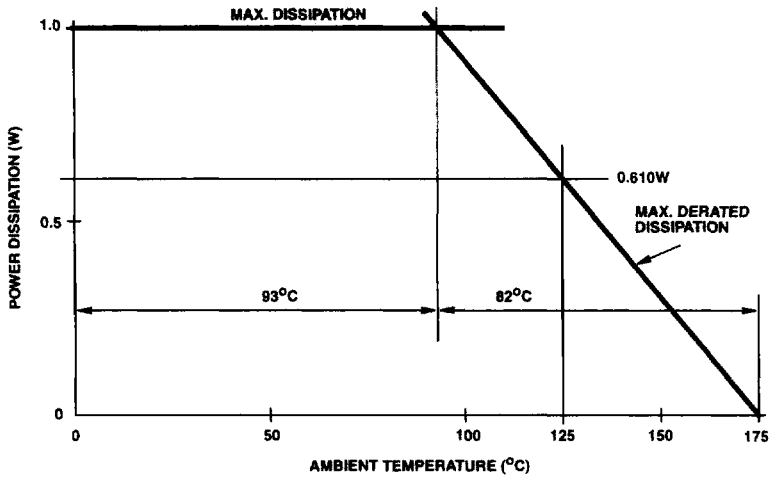

FIGURE 6. TYPICAL APPLICATION OF THE SP720 AS AN INPUT CLAMP FOR OVER-VOLTAGE, GREATER THAN  $1V_{BE}$  ABOVE  $V_+$  OR LESS THAN  $-1V_{BE}$  BELOW  $V_-$ . PINOUT SHOWN IS FOR THE SP720MD SBDIP PACKAGE.

**SP720MD-8, SP720MD, SP720MM-8, SP720MM**

**Power Dissipation Derating Curves**



**FIGURE 7. SP720MD DERATING CURVE FOR THE 82°C/W THERMAL RESISTANCE OF THE SIDEBRAZE 16 LEAD CERAMIC PACKAGE, DERATED 12.2mW/°C FROM A MAXIMUM P<sub>D</sub> OF 1.0W AT 93°C**

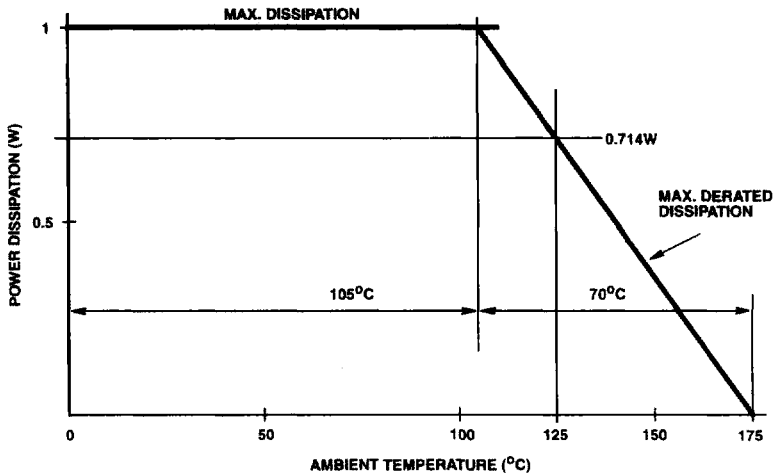

**FIGURE 8. SP720MM DERATING CURVE FOR THE 70°C/W THERMAL RESISTANCE OF THE 20 PAD CERAMIC LCC PACKAGE, DERATED 14.3mW/°C FROM A MAXIMUM P<sub>D</sub> OF 1.0W AT 105°C**

**SP720MD-8, SP720MD, SP720MM-8, SP720MM**

**SP720MD-8 and SP720MM-8 Dynamic Burn-In Circuits**

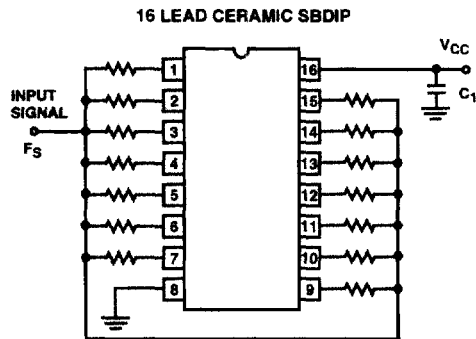

**NOTES:**

4. All resistors  $1k\Omega \pm 10\%$
5.  $V_{CC} = 30V \pm 1\%$
6.  $F_S = 0V$  to  $30V \pm 1\%$ , 50% Duty Cycle
7.  $C_1 = 22\mu F$  Min. Tantalum, 50WV (33WV at  $125^\circ C$ )
8.  $T_{AMB} = 125^\circ C$

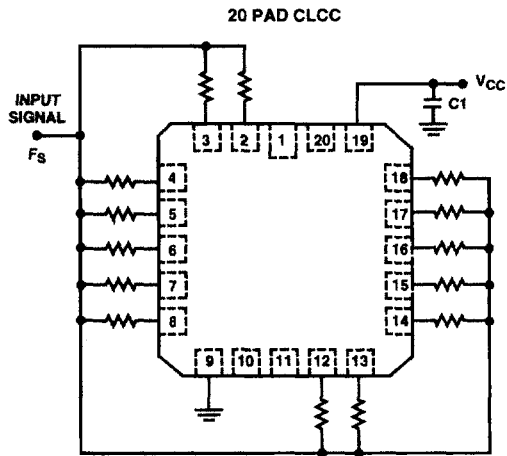

## SP720MD-8, SP720MD, SP720MM-8, SP720MM

### Die Characteristics

#### DIE DIMENSIONS:

51 x 84 x 14 ±1mils

#### METALLIZATION:

Type: Al

Thickness: 17.5kÅ ±2.5kÅ

#### PASSIVATION:

Type: SiO<sub>2</sub>

Thickness: 13kÅ ±2.6kÅ

#### SUBSTRATE POTENTIAL (POWERED UP):

V-

#### WORST CASE CURRENT DENSITY:

9.18 x 10<sup>4</sup>A/cm<sup>2</sup> at 70mA

#### PROCESS:

Bipolar

### Metallization Mask Layout

SP720MD-8, SP720MD, SP720MM-8, SP720MM

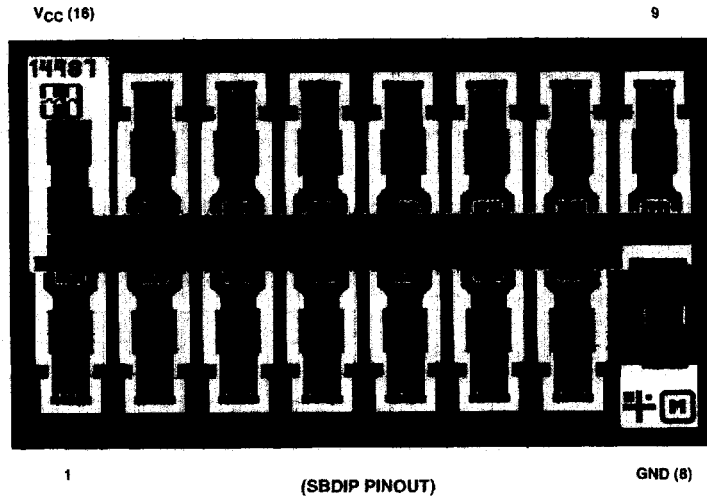

10

HIGH RELIABILITY  
SERIES

SP720MD-8, SP720MD, SP720MM-8, SP720MM

Ceramic Dual-In-Line Metal Seal Packages (SBDIP)

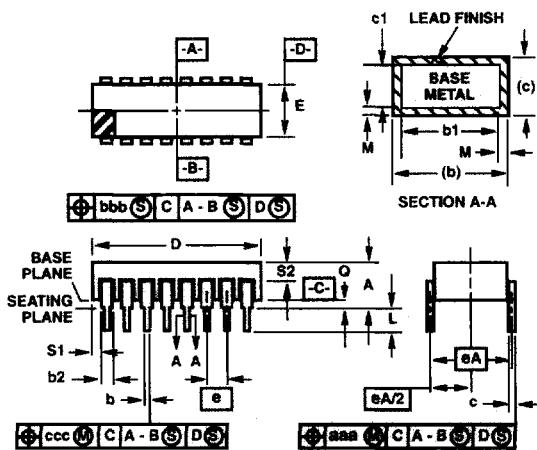

D16.3 MIL-STD-1835 CDIP2-T16 (D-2, CONFIGURATION C)  
16 LEAD CERAMIC DUAL-IN-LINE METAL SEAL PACKAGE

SYMBOL	INCHES		MILLIMETERS		NOTES
	MIN	MAX	MIN	MAX	
A	-	0.200	-	5.08	-
b	0.014	0.026	0.36	0.66	2
b1	0.014	0.023	0.36	0.58	3
b2	0.045	0.065	1.14	1.65	-
b3	0.023	0.045	0.58	1.14	4
c	0.008	0.018	0.20	0.46	2
c1	0.008	0.015	0.20	0.38	3
D	-	0.840	-	21.34	-
E	0.220	0.310	5.59	7.87	-
e	0.100 BSC		2.54 BSC		-
eA	0.300 BSC		7.62 BSC		-
eA/2	0.150 BSC		3.81 BSC		-
L	0.125	0.200	3.18	5.08	-
Q	0.015	0.060	0.38	1.52	5
S1	0.005	-	0.13	-	6
S2	0.005	-	0.13	-	7
$\alpha$	90°	105°	90°	105°	-
aaa	-	0.015	-	0.38	-
bbb	-	0.030	-	0.76	-
ccc	-	0.010	-	0.25	-
M	-	0.0015	-	0.038	2
N	16		16		8

NOTES:

1. Index area: A notch or a pin one identification mark shall be located adjacent to pin one and shall be located within the shaded area shown. The manufacturer's identification shall not be used as a pin one identification mark.
2. The maximum limits of lead dimensions b and c or M shall be measured at the centroid of the finished lead surfaces, when solder dip or tin plate lead finish is applied.
3. Dimensions b1 and c1 apply to lead base metal only. Dimension M applies to lead plating and finish thickness.
4. Corner leads (1, N, N/2, and N/2+1) may be configured with a partial lead paddle. For this configuration dimension b3 replaces dimension b2.
5. Dimension Q shall be measured from the seating plane to the base plane.
6. Measure dimension S1 at all four corners.
7. Measure dimension S2 from the top of the ceramic body to the nearest metallization or lead.
8. N is the maximum number of terminal positions.
9. Braze fillets shall be concave.
10. Dimensioning and tolerancing per ANSI Y14.5M - 1982.
11. Controlling dimension: INCH.

Rev. 0 4/94

SP720MD-8, SP720MD, SP720MM-8, SP720MM

Ceramic Leadless Chip Carrier Packages (CLCC)

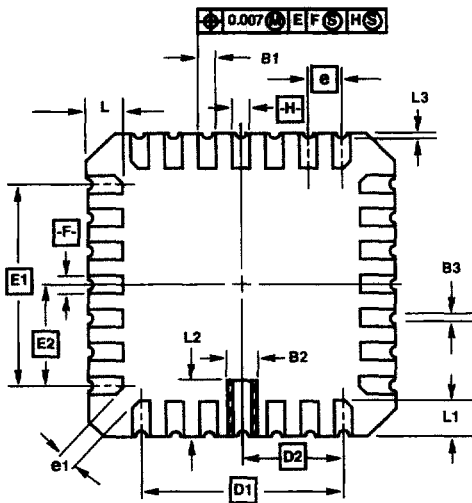
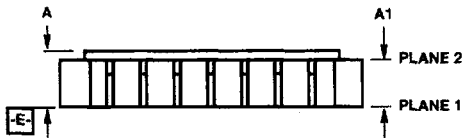
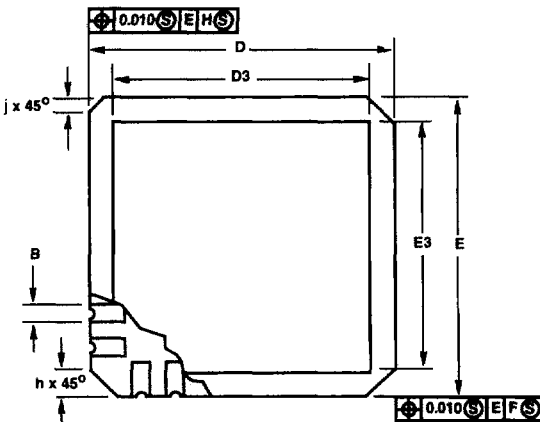

J20.A MIL-STD-1835 CQCC1-N20 (C-2)  
20 PAD CERAMIC LEADLESS CHIP CARRIER PACKAGE

SYMBOL	INCHES		MILLIMETERS		NOTES
	MIN	MAX	MIN	MAX	
A	0.060	0.100	1.52	2.54	6, 7
A1	0.050	0.088	1.27	2.23	-
B	-	-	-	-	-
B1	0.022	0.028	0.56	0.71	2.4
B2	0.072 REF		1.83 REF		-
B3	0.006	0.022	0.15	0.56	-
D	0.342	0.358	8.69	9.09	-
D1	0.200 BSC		5.08 BSC		-
D2	0.100 BSC		2.54 BSC		-
D3	-	0.358	-	9.09	2
E	0.342	0.358	8.69	9.09	-
E1	0.200 BSC		5.08 BSC		-
E2	0.100 BSC		2.54 BSC		-
E3	-	0.358	-	9.09	2
e	0.050 BSC		1.27 BSC		-
e1	0.015	-	0.38	-	2
h	0.040 REF		1.02 REF		5
j	0.020 REF		0.51 REF		5
L	0.045	0.055	1.14	1.40	-
L1	0.045	0.055	1.14	1.40	-
L2	0.075	0.095	1.91	2.41	-
L3	0.003	0.015	0.08	0.38	-
ND	5		5		3
NE	5		5		3
N	20		20		3

Rev. 0 5/18/94

NOTES:

1. Metallized castellations shall be connected to plane 1 terminals and extend toward plane 2 across at least two layers of ceramic or completely across all of the ceramic layers to make electrical connection with the optional plane 2 terminals.
2. Unless otherwise specified, a minimum clearance of 0.015 inch (0.38mm) shall be maintained between all metallized features (e.g., lid, castellations, terminals, thermal pads, etc.)
3. Symbol "N" is the maximum number of terminals. Symbols "ND" and "NE" are the number of terminals along the sides of length "D" and "E", respectively.
4. The required plane 1 terminals and optional plane 2 terminals (if used) shall be electrically connected.
5. The corner shape (square, notch, radius, etc.) may vary at the manufacturer's option, from that shown on the drawing.
6. Chip carriers shall be constructed of a minimum of two ceramic layers.
7. Dimension "A" controls the overall package thickness. The maximum "A" dimension is package height before being solder dipped.
8. Dimensioning and tolerancing per ANSI Y14.5M-1982.
9. Controlling dimension: INCH.

10  
HIGH RELIABILITY  
SERIES