

4-BIT SHIFTER (With 3-State Outputs)

The MC54/74F350 is a specialized multiplexer that accepts a 4-bit word and shifts it 0, 1, 2 or 3 places, as determined by two Select (S_0, S_1) inputs. For expansion to longer words, three linking inputs are provided for lower-order bits; thus two packages can shift an 8-bit word, four packages a 16-bit word, etc. Shifting by more than three places is accomplished by paralleling the 3-state outputs of different packages and using the Output Enable (\overline{OE}) inputs as a third Select level. With appropriate interconnections, the F350 can perform zero-backfill, sign-extend or end-around (barrel) shift functions.

- Linking Inputs for Word Expansion
- 3-State Outputs for Extending Shift Range

FUNCTIONAL DESCRIPTION

The F350 is operationally equivalent to a 4-input multiplexer with the inputs connected so that the select code causes successive one-bit shifts of the data word. This internal connection makes it possible to perform shifts of 0, 1, 2 or 3 places on words of any length.

A 7-bit data word is introduced at the I_n inputs and is shifted according to the code applied to the select inputs S_0, S_1 . Outputs O_0-O_3 are 3-state, controlled by an active-LOW output enable (\overline{OE}). When \overline{OE} is LOW, data outputs will follow selected data inputs; when HIGH, the data outputs will be forced to the high-impedance state. This feature allows shifters to be cascaded on the same output lines or to a common bus. The shift function can be logical, with zeros pulled in at either or both ends of the shifting field; arithmetic, where the sign bit is repeated during a shift down; or end around, where the data word forms a continuous loop.

LOGIC EQUATIONS

$$O_0 = \overline{S_0} \overline{S_1} I_0 + S_0 \overline{S_1} I_{-1} + \overline{S_0} S_1 I_{-2} + S_0 S_1 I_{-3}$$

$$O_1 = \overline{S_0} \overline{S_1} I_1 + S_0 \overline{S_1} I_0 + \overline{S_0} S_1 I_{-1} + S_0 S_1 I_{-2}$$

$$O_2 = \overline{S_0} \overline{S_1} I_2 + S_0 \overline{S_1} I_1 + \overline{S_0} S_1 I_0 + S_0 S_1 I_{-1}$$

$$O_3 = \overline{S_0} \overline{S_1} I_3 + S_0 \overline{S_1} I_2 + \overline{S_0} S_1 I_1 + S_0 S_1 I_0$$

TRUTH TABLE

Inputs			Outputs			
\overline{OE}	S_1	S_0	O_0	O_1	O_2	O_3
H	X	X	Z	Z	Z	Z
L	L	L	I_0	I_1	I_2	I_3
L	L	H	I_{-1}	I_0	I_1	I_2
L	H	L	I_{-2}	I_{-1}	I_0	I_1
L	H	H	I_{-3}	I_{-2}	I_{-1}	I_0

H = HIGH Voltage Level
L = LOW Voltage Level

Z = High Impedance
X = Immaterial

CONNECTION DIAGRAM

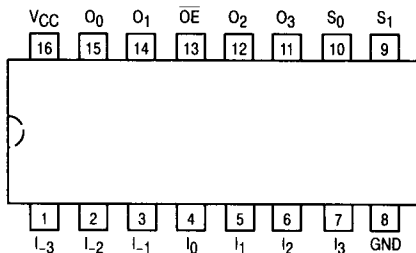

MC54/74F350

4-BIT SHIFTER (With 3-State Outputs)

FAST™ SCHOTTKY TTL

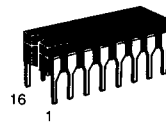

J SUFFIX
CERAMIC
CASE 620-09

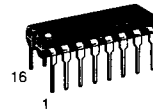

N SUFFIX
PLASTIC
CASE 648-08

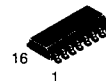

D SUFFIX
SOIC
CASE 751B-03

ORDERING INFORMATION

MC54FXXXJ Ceramic
MC74FXXXN Plastic
MC74FXXXD SOIC

LOGIC SYMBOL

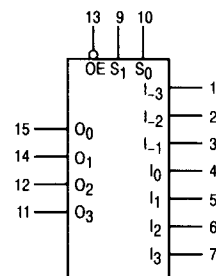

V_{CC} = PIN 16
GND = PIN 8

MC54/74F350

LOGIC DIAGRAM

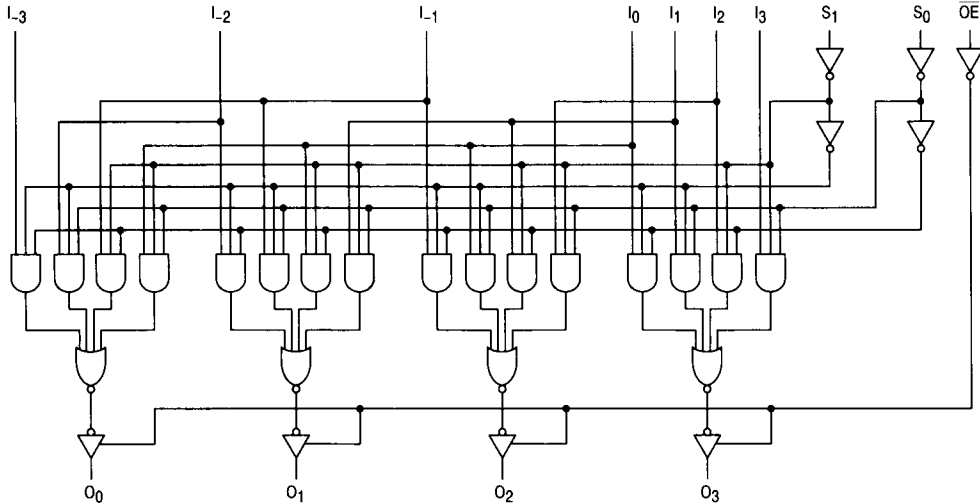

GUARANTEED OPERATING RANGES

Symbol	Parameter		Min	Typ	Max	Unit
V _{CC}	Supply Voltage	54, 74	4.5	5.0	5.5	V
T _A	Operating Ambient Temperature Range	54	-55	25	125	°C
		74	0	25	70	
I _{OH}	Output Current — High	54, 74	—	—	-3.0	mA
I _{OL}	Output Current — Low	54, 74	—	—	24	mA

DC CHARACTERISTICS OVER OPERATING TEMPERATURE RANGE (unless otherwise specified)

Symbol	Parameter	Limits			Unit	Test Conditions	
		Min	Typ	Max			
V _{IH}	Input HIGH Voltage	2.0			V	Guaranteed Input HIGH Voltage	
V _{IL}	Input LOW Voltage			0.8	V	Guaranteed Input LOW Voltage	
V _{IK}	Input Clamp Diode Voltage			-1.2	V	I _{IIN} = -18 mA	V _{CC} = MIN
V _{OH}	Output HIGH Voltage	54, 74	2.4	3.3	V	I _{OH} = -3.0 mA	V _{CC} = 4.5 V
		74	2.7	3.3	V	I _{OH} = -3.0 mA	V _{CC} = 4.75 V
V _{OL}	Output LOW Voltage		0.35	0.5	V	I _{OL} = 24 mA	V _{CC} = MIN
I _{OZH}	Output OFF Current — HIGH			50	μA	V _{OUT} = 2.7 V	V _{CC} = MAX
I _{OZL}	Output OFF Current — LOW			-50	μA	V _{OUT} = 0.5 V	V _{CC} = MAX
I _{IH}	Input HIGH Current			20	μA	V _{IN} = 2.7 V	V _{CC} = MAX
				100		V _{IN} = 7.0 V	
I _{IL}	Input LOW Current			-1.2	mA	V _{IN} = 0.5 V	V _{CC} = MAX
I _{OS}	Output Short Circuit Current (Note 2)	-60		-150	mA	V _{OUT} = 0 V	V _{CC} = MAX
I _{CCH}	Power Supply Current		22	35	mA	Outputs HIGH	V _{CC} = MAX
I _{CCL}			26	41		Outputs LOW	
I _{CCZ}			26	42		Outputs OFF	

NOTES: 1. For conditions such as MIN or MAX, use the appropriate value specified under guaranteed operating ranges.

2. Not more than one output should be shorted at a time, nor for more than 1 second.

MC54/74F350

AC CHARACTERISTICS

Symbol	Parameter	54/74F		54F		74F		Unit
		T _A = +25°C V _{CC} = +5.0 V C _L = 50 pF		T _A = -55 to +125°C V _{CC} = 5.0 V ±10% C _L = 50 pF		T _A = 0 to +70°C V _{CC} = 5.0 V ±10% C _L = 50 pF		
		Min	Max	Min	Max	Min	Max	
t _{PLH} t _{PHL}	Propagation Delay I _n to O _n	3.0 2.5	6.0 5.5	3.0 2.5	7.5 7.0	3.0 2.5	7.0 6.5	ns
t _{PLH} t _{PHL}	Propagation Delay S _n to O _n	4.0 3.0	10 8.5	4.0 3.0	13.5 10	4.0 3.0	11 9.5	ns
t _{PZH} t _{PZL}	Output Enable Time	2.5 4.0	7.0 9.0	2.5 4.0	10.5 11	2.5 4.0	8.0 10	ns
t _{PHZ} t _{PLZ}	Output Disable Time	2.0 1.5	5.5 5.5	2.0 1.5	7.0 9.0	2.0 1.5	6.5 6.5	ns

APPLICATIONS

16-Bit Shift-Up 0 to 3 Pieces, Zero Backfill

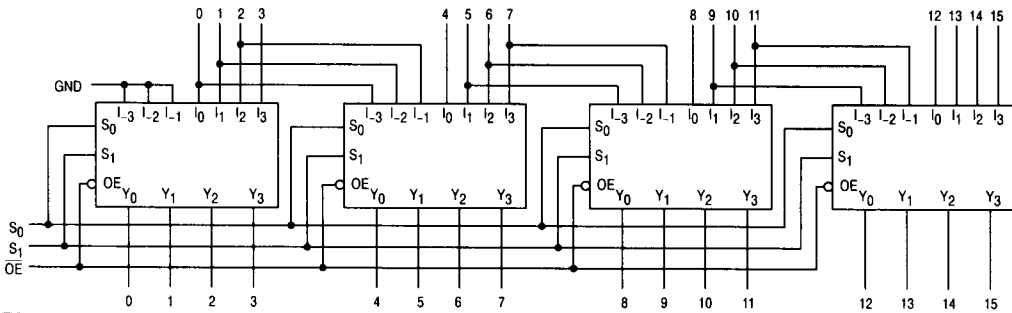

S ₁	S ₀	
L	L	NO SHIFT
L	H	SHIFT 1 PLACE
H	L	SHIFT 2 PLACES
H	H	SHIFT 3 PLACES

MC54/74F350

8-Bit End Around Shift 0 to 7 Pieces

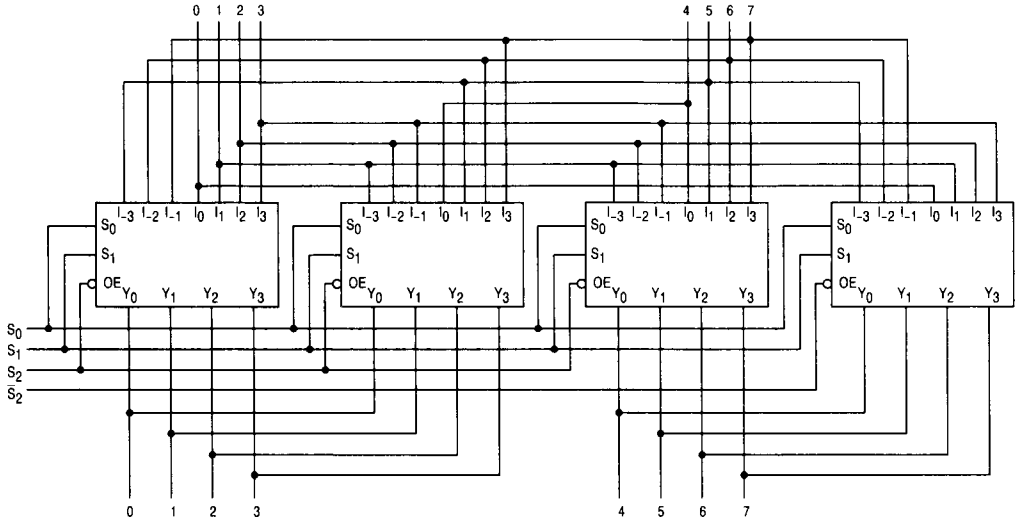

S ₂	S ₁	S ₀	
L	L	L	NO SHIFT
L	L	H	SHIFT END AROUND 1
L	H	L	SHIFT END AROUND 2
L	H	H	SHIFT END AROUND 3
H	L	L	SHIFT END AROUND 4

S ₂	S ₁	S ₀	
H	L	H	SHIFT END AROUND 5
H	H	L	SHIFT END AROUND 6
H	H	H	SHIFT END AROUND 7

13-Bit Twos Complement Scaler

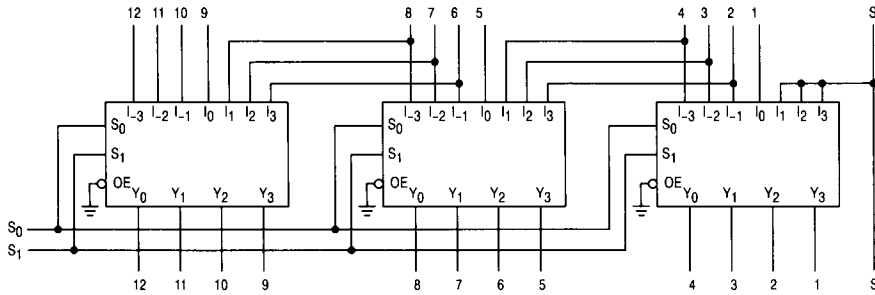

S ₁	S ₀	SCALE
L	L	L ÷ 8
L	H	H ÷ 4
H	L	L ÷ 2
H	H	H NO CHANGE

4