

# 32-bit Microcontroller

CMOS

## FR60 MB91460N Series

# MB91F463NA/F463NB/V460A

### ■ DESCRIPTION

MB91F463NA is a line of the general-purpose 32-bit RISC microcontrollers designed for embedded control applications which require high-speed real-time processing, such as consumer devices and on-board vehicle systems. MB91F463NA uses the FR60 CPU which is compatible with the FR\* CPUs.

MB91F463NA contains the LIN-USART and CAN controllers.

\* : FR, the abbreviation of FUJITSU RISC controller, is a line of products of Fujitsu Microelectronics Limited.

Note: MB91F463NB includes the improved features of MB91F463NA.  
Please select MB91F463NB for the future development.

### ■ FEATURES

#### • FR60 CPU

- 32-bit RISC, load/store architecture, five-stage pipeline
- Maximum operating frequency: 80 MHz (oscillator frequency: 4 MHz; oscillator frequency multiplier: 20 (PLL clock multiplication method))
- 16-bit fixed-length instructions (basic instructions)
- Instruction execution speed: 1 instruction per cycle
- Instructions including memory-to-memory transfer, bit manipulation instructions, and barrel shift instructions: Instructions suitable for embedded applications
- Function entry/exit instructions and register data multi load store instructions: Instructions supporting C language
- Register interlock function: Facilitating assembly-language coding

(Continued)

For the information for microcontroller supports, see the following web site.

<http://edevic.fujitsu.com/micom/en-support/>

# MB91460N Series

- Built-in multiplier with instruction-level support
  - Signed 32-bit multiplication : 5 cycles
  - Signed 16-bit multiplication : 3 cycles
- Interrupt (PC/PS saving): 6 cycles (16 priority levels)
- Harvard architecture allowing program access and data access to be executed simultaneously
- Instructions compatible with the FR family
- Internal peripheral resources
  - Flash memory capacity : 288 Kbytes
  - Internal RAM capacity: 8 Kbytes (Data RAM) + 2 Kbytes (Instruction/data RAM)
  - General-purpose port: Maximum 48 ports
  - DMAC (DMA Controller)
    - Maximum of 5 channels for able to operate simultaneously
    - 2 transfer sources (internal peripheral/software)
    - Activation source can be selected by programs
    - Addressing mode specifies full 32-bit addresses (increment/decrement/fixed)
    - Transfer mode (burst transfer/step transfer/block transfer)
    - Transfer data size selectable from 8/16/32-bit
    - Multi-byte transfer capable (by programs)
    - DMAC descriptor in I/O areas (200<sub>H</sub> to 240<sub>H</sub>, 1000<sub>H</sub> to 1024<sub>H</sub>)
  - A/D converter (sequential comparison)
    - 10-bit resolution: 8 channels
    - Conversion time: 1  $\mu$ s (using at 5 V) , 3  $\mu$ s (using at 3.3 V)
  - External interrupt inputs: 10 channels
  - Bit search module (for REALOS)
    - Function to search from the MSB (most significant bit) for the position of the first "0", "1" or changed bit in a word
  - LIN-USART (full duplex double buffer): 4 channels
    - Clock synchronous/asynchronous selectable
    - Sync-break detection
    - Internal dedicated baud rate generator
  - I<sup>2</sup>C bus interface (Supports 400 kbps): 2 channels
    - Master/slave transmission and reception
    - Arbitration function, clock synchronization function
  - CAN controller (C-CAN): 2 channels
    - Maximum transfer speed: 1 Mbps
    - 32 transmission/reception message buffers
  - 16-bit PPG timer: 8 channels
  - 16-bit reload timer: 4 channels + 1 channel (exclusive A/D converter)
  - 16-bit free-run timer: 4 channels
  - Input capture: 4 channels
  - Output compare: 4 channels
  - 8/16-bit up/down counter: 2 channels (8-bit)/1channel (16-bit)
  - Watchdog timer
  - Real-time clock
  - Low-power consumption mode: Sleep/stop mode function

(Continued)

*(Continued)*

- Package: LQFP-64 (FPT-64P-M23)
- CMOS 0.18  $\mu\text{m}$  technology
- 3.3 V only power supplies or 5 V only power supplies
- Operating temperature range:  $-40^{\circ}\text{C}$  to  $+85^{\circ}\text{C}$  (using at 5 V)  
 $-40^{\circ}\text{C}$  to  $+105^{\circ}\text{C}$  (using at 3.3 V)

# MB91460N Series

## ■ PRODUCT LINEUP

Part number Parameter	MB91V460A	MB91F463NA MB91F463NB
Max core frequency (CLKB)	80 MHz	
Max resource frequency (CLKP)	40 MHz	
Max external bus frequency (CLKT)	40 MHz	—
Max CAN frequency (CLKCAN)	20 MHz	
Technology	0.35 $\mu$ m	0.18 $\mu$ m
Watchdog Timer	Yes	No
Watchdog Timer (CR oscillator)	Yes (disengageable)	Yes
Bit search	Yes	
Reset input (INITX)	Yes	
Hardware standby input (HSTX)	Yes	No
Clock modulator	Yes	
Low-power mode	Yes	
DMAC	5 channels	
MAC ( $\mu$ DSP)	No	
MMU/MPU	MPU (16 channels)*	MPU (4 channels)*
Flash memory	Emulation SRAM 32-bit read data	288 Kbytes
Flash protection	—	Yes
Data RAM	64 Kbytes	8 Kbytes
Instruction/data RAM	64 Kbytes	2 Kbytes
Flash-cache (instruction cache)	16 Kbytes	4 Kbytes
Boot-ROM/BI-ROM	4 Kbytes fixed	4 Kbytes (BI-ROM)
Real-time clock	1 channels	
Free-run timer	8 channels	4 channels
ICU	8 channels	4 channels
OCU	8 channels	4 channels
16-bit reload timer	8 channels	4 channels + 1 channel
16-bit PPG	16 channels	8 channels

(Continued)

# MB91460N Series

(Continued)

Part number Parameter	MB91V460A	MB91F463NA MB91F463NB
16-bit PFM	1 channel	No
Sound Generator	1 channel	No
8/16-bit up/down counter	4 channels (8-bit) / 2 channels (16-bit)	2 channels (8-bit) / 1 channel (16-bit)
C_CAN	6 channels (128 message buffers)	2 channels (32 message buffers)
LIN-USART	4 channels + 4 channels (FIFO) + 8 channels	4 channels
I <sup>2</sup> C (400 kbps)	4 channels	2 channels
FR external bus	Yes (32-bit address, 32-bit data)	No
External interrupt	16 channels	10 channels
NMI interrupts	Yes	No
Stepping motor controller (SMC)	6 channels	No
LCD controller (40 × 4)	1 channel	No
10-bit A/D converter	32 channels	8 channels
Alarm comparator	2 channels	No
Clock supervisor	Yes	No
Main clock oscillator	4 MHz	
Sub clock oscillator	32 kHz	—
CR oscillator	100 kHz	100 kHz / 2 MHz
PLL	× 20	
DSU4	Yes	No
EDSU	Yes (32 BP) *	Yes (8 BP)*
Power supply voltage	3 V / 5 V	
Regulator	Yes	
Power consumption	n.a.	< 700 mW
Temperature range (T <sub>A</sub> )	0 °C to +70 °C	- 40 °C to + 105 °C
Package	BGA-660	LQFP-64

\* : MPU channels use EDSU breakpoint registers (shared operation between MPU and EDSU).

# MB91460N Series

## PIN ASSIGNMENT

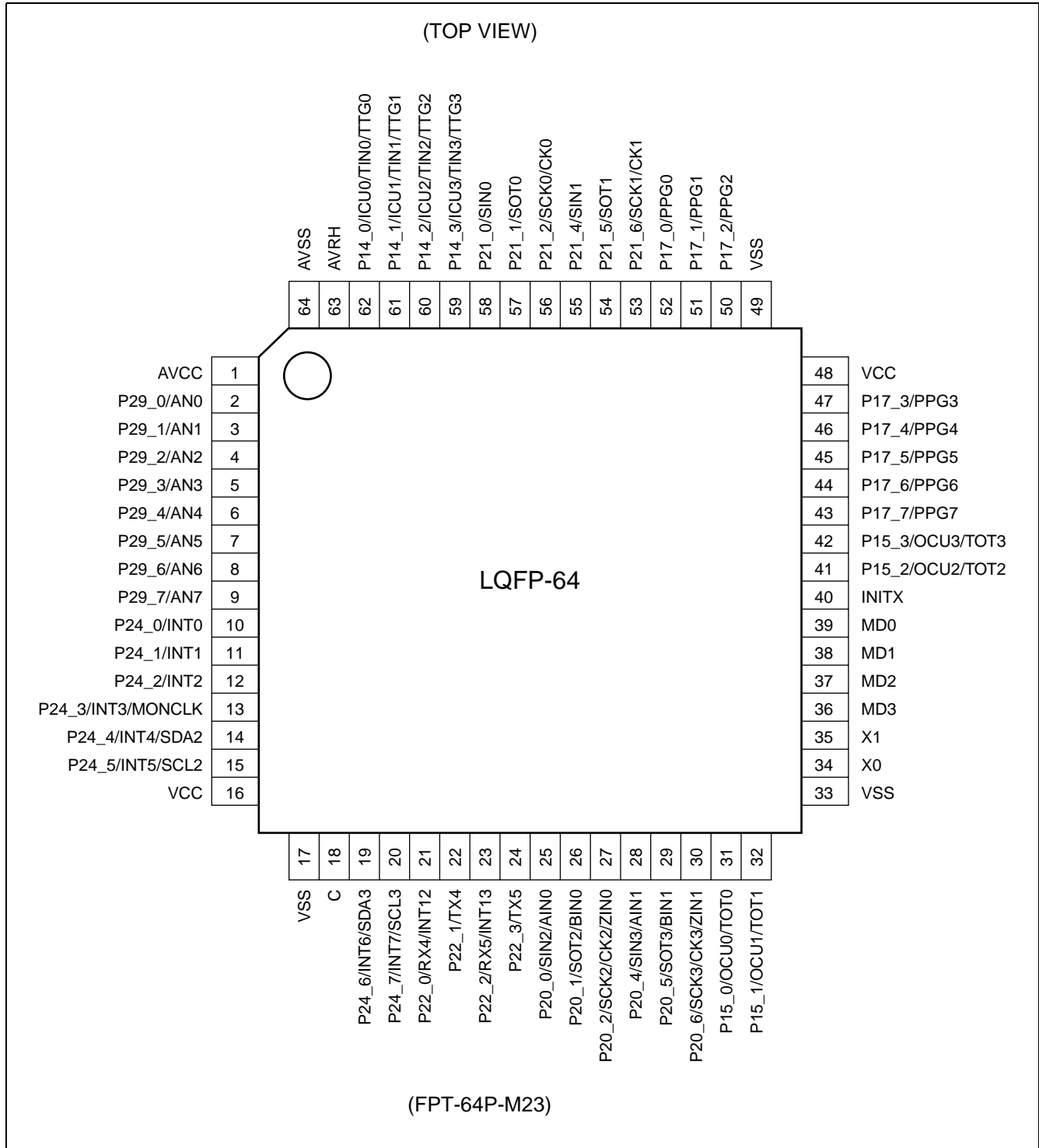

## ■ PIN DESCRIPTION

Pin no.	Pin name	I/O	I/O circuit type*	Function
2 to 9	P29_0 to P29_7	I/O	B	General-purpose input/output ports
	AN0 to AN7			Analog input pins for A/D converter
10 to 12	P24_0 to P24_2	I/O	A	General-purpose input/output ports
	INT0 to INT2			External interrupt input pins
13	P24_3	I/O	A	General-purpose input/output port
	INT3			External interrupt input pins
	MONCLK			Clock monitor output pin
14	P24_4	I/O	C	General-purpose input/output port
	INT4			External interrupt input pin
	SDA2			I <sup>2</sup> C bus data input/output pin
15	P24_5	I/O	C	General-purpose input/output port
	INT5			External interrupt input pin
	SCL2			I <sup>2</sup> C bus clock input/output pin
19	P24_6	I/O	C	General-purpose input/output port
	INT6			External interrupt input pin
	SDA3			I <sup>2</sup> C bus data input/output pin
20	P24_7	I/O	C	General-purpose input/output port
	INT7			External interrupt input pin
	SCL3			I <sup>2</sup> C bus clock input/output pin
21	P22_0	I/O	A	General-purpose input/output port
	RX4			RX input pin of CAN4
	INT12			External interrupt input pin
22	P22_1	I/O	A	General-purpose input/output port
	TX4			TX output pin of CAN4
23	P22_2	I/O	A	General-purpose input/output port
	RX5			RX input pin of CAN5
	INT13			External interrupt input pin
24	P22_3	I/O	A	General-purpose input/output port
	TX5			TX output pin of CAN5
25	P20_0	I/O	A	General-purpose input/output port
	SIN2			Data input pin of LIN-USART2
	AIN0			Up/down counter input pin
26	P20_1	I/O	A	General-purpose input/output port
	SOT2			Data output pin of LIN-USART2
	BIN0			Up/down counter input pin

(Continued)

# MB91460N Series

Pin no.	Pin name	I/O	I/O circuit type*	Function
27	P20_2	I/O	A	General-purpose input/output port
	SCK2			Clock input/output pin of LIN-USART2
	CK2			Free-run timer input pin
	ZIN0			Up/down counter input pin
28	P20_4	I/O	A	General-purpose input/output port
	SIN3			Data input pin of LIN-USART3
	AIN1			Up/down counter input pin
29	P20_5	I/O	A	General-purpose input/output port
	SOT3			Data output pin of LIN-USART3
	BIN1			Up/down counter input pin
30	P20_6	I/O	A	General-purpose input/output port
	SCK3			Clock input/output pin of LIN-USART3
	CK3			Free-run timer input pin
	ZIN1			Up/down counter input pin
31	P15_0	I/O	A	General-purpose input/output port
	OCU0			Output compare output pin
	TOT0			Reload timer output pin
32	P15_1	I/O	A	General-purpose input/output port
	OCU1			Output compare output pin
	TOT1			Reload timer output pin
34	X0	—	J	Clock (oscillation) input
35	X1	—	J	Clock (oscillation) output
36	MD3	I	I	Mode setting pin
37	MD2	I	G	Mode setting pin
38	MD1	I	G	Mode setting pin
39	MD0	I	G	Mode setting pin
40	INITX	I	H	External reset input
41	P15_2	I/O	A	General-purpose input/output port
	OCU2			Output compare output pin
	TOT2			Reload timer output pin
42	P15_3	I/O	A	General-purpose input/output port
	OCU3			Output compare output pin
	TOT3			Reload timer output pin
43 to 47, 50 to 52	P17_7 to P17_0	I/O	A	General-purpose input/output ports
	PPG7 to PPG0			PPG timer output pins

(Continued)

(Continued)

Pin no.	Pin name	I/O	I/O circuit type*	Function
53	P21_6	I/O	A	General-purpose input/output port
	SCK1			Clock input/output pin of LIN-USART1
	CK1			Free-run timer input pin
54	P21_5	I/O	A	General-purpose input/output port
	SOT1			Data output pin of LIN-USART1
55	P21_4	I/O	A	General-purpose input/output port
	SIN1			Data input pin of LIN-USART1
56	P21_2	I/O	A	General-purpose input/output port
	SCK0			Clock input/output pin of LIN-USART0
	CK0			Free-run timer input pin
57	P21_1	I/O	A	General-purpose input/output port
	SOT0			Data output pin of LIN-USART0
58	P21_0	I/O	A	General-purpose input/output port
	SIN0			Data input pin of LIN-USART0
59	P14_3	I/O	A	General-purpose input/output port
	ICU3			Input capture input pin
	TIN3			External trigger input pin of reload timer
	TTG3			PPG timer input pin
60	P14_2	I/O	A	General-purpose input/output port
	ICU2			Input capture input pin
	TIN2			External trigger input pin of reload timer
	TTG2			PPG timer input pin
61	P14_1	I/O	A	General-purpose input/output port
	ICU1			Input capture input pin
	TIN1			External trigger input pin of reload timer
	TTG1			PPG timer input pin
62	P14_0	I/O	A	General-purpose input/output port
	ICU0			Input capture input pin
	TIN0			External trigger input pin of reload timer
	TTG0			PPG timer input pin

\* : For I/O circuit type, refer to “■ I/O CIRCUIT TYPE”.

# MB91460N Series

## [Power supply/GND pins]

Pin no.	Pin name	I/O	Function
17, 33, 49	VSS	—	GND pins
16, 48	VCC	—	3.3 V/5 V power supply pins
64	AVSS	—	Analog GND pin for A/D converter
1	AVCC	—	3.3 V/5 V power supply pin for A/D converter
63	AVRH	—	Reference power supply pin for A/D converter
18	C	—	Capacitor connection pin for internal regulator

## I/O CIRCUIT TYPE

Type	Circuit	Remarks
A	<p>Pull-up control</p> <p>Driver strength control</p> <p>Data line</p> <p>Pull-down control</p> <p>R</p> <p>CMOS hysteresis input type1</p> <p>CMOS hysteresis input type2</p> <p>Automotive input</p> <p>TTL input</p> <p>Standby control for input shutdown</p>	<ul style="list-style-type: none"> <li>• CMOS level output (programmable <math>I_{OL} = 5\text{mA}</math>, <math>I_{OH} = -5\text{mA}</math>, <math>I_{OL} = 2\text{mA}</math>, <math>I_{OH} = -2\text{mA}</math>)</li> <li>• 2 different CMOS hysteresis inputs with input shutdown function</li> <li>• Automotive input with input shutdown function</li> <li>• TTL input with input shutdown function</li> <li>• Programmable pull-up resistor : approx.50 k<math>\Omega</math></li> </ul>
B	<p>Pull-up control</p> <p>Driver strength control</p> <p>Data line</p> <p>Pull-down control</p> <p>R</p> <p>CMOS hysteresis input type1</p> <p>CMOS hysteresis input type2</p> <p>Automotive input</p> <p>TTL input</p> <p>Standby control for input shutdown</p> <p>Analog input</p>	<ul style="list-style-type: none"> <li>• CMOS level output (programmable <math>I_{OL} = 5\text{mA}</math>, <math>I_{OH} = -5\text{mA}</math>, <math>I_{OL} = 2\text{mA}</math>, <math>I_{OH} = -2\text{mA}</math>)</li> <li>• 2 different CMOS hysteresis inputs with input shutdown function</li> <li>• Automotive input with input shutdown function</li> <li>• TTL input with input shutdown function</li> <li>• Programmable pull-up resistor : approx.50 k<math>\Omega</math></li> <li>• Analog input</li> </ul>

(Continued)

# MB91460N Series

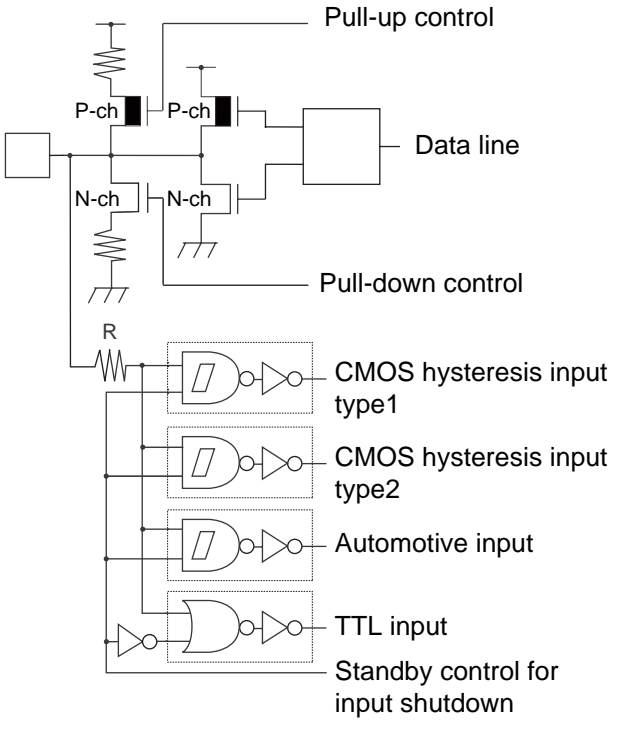
Type	Circuit	Remarks
C	 <p>The diagram shows a CMOS input circuit. A data line is connected to a CMOS inverter. The input of this inverter is connected to a pull-up resistor (controlled by a 'Pull-up control' signal) and a pull-down network consisting of an N-channel MOSFET (controlled by a 'Pull-down control' signal) and a resistor 'R'. Below the resistor 'R', there are four input stages: a CMOS hysteresis input type 1 (a NAND gate with a feedback loop), a CMOS hysteresis input type 2 (a NAND gate with a feedback loop), an Automotive input (a NAND gate with a feedback loop), and a TTL input (a NAND gate with a feedback loop). A 'Standby control for input shutdown' signal is connected to the inputs of these four stages.</p>	<ul style="list-style-type: none"> <li>• CMOS level output (<math>I_{OL} = 3 \text{ mA}</math>, <math>I_{OH} = -3 \text{ mA}</math>)</li> <li>• 2 different CMOS hysteresis inputs with input shutdown function</li> <li>• Automotive input with input shutdown function</li> <li>• TTL input with input shutdown function</li> <li>• Programmable pull-up resistor : approx.50 k<math>\Omega</math></li> </ul>

(Continued)

(Continued)

Type	Circuit	Remarks
G	<p>CMOS level input</p>	<ul style="list-style-type: none"> <li>• MASK ROM and evaluation device: CMOS level input</li> <li>• Flash device :               <ul style="list-style-type: none"> <li>- CMOS level input</li> <li>- 12 V resistant (for MD [2:0])</li> </ul> </li> </ul>
H	<p>Pull-up resistor</p> <p>CMOS Hysteresis input</p>	<ul style="list-style-type: none"> <li>• CMOS hysteresis input</li> <li>• Pull-up resistor value : approx.50 kΩ</li> </ul>
I	<p>Pull-down resistor</p> <p>CMOS Hysteresis input</p>	<ul style="list-style-type: none"> <li>• CMOS hysteresis input</li> <li>• Pull-down resistor value : approx.50 kΩ</li> </ul>
J	<p>Standby control signal</p> <p>Xout</p>	Oscillation circuit

## ■ PRECAUTIONS FOR HANDLING THE DEVICES

Any semiconductor devices have inherently a certain rate of failure. The possibility of failure is greatly affected by the conditions in which they are used (circuit conditions, environmental conditions, etc.). This page describes precautions that must be observed to minimize the chance of failure and to obtain higher reliability from your FUJITSU semiconductor devices.

### 1. Precautions for Product Design

This section describes precautions when designing electronic equipment using semiconductor devices.

- Absolute Maximum Ratings

Semiconductor devices can be permanently damaged by application of stress (voltage, current, temperature, etc.) in excess of absolute maximum ratings. Do not exceed these ratings.

- Recommended Operating Conditions

The recommended operating conditions are required in order to ensure the normal operation of the semiconductor device. All of the device's electrical characteristics are warranted when the device is operated within these ranges.

Always use semiconductor devices within their recommended operating condition ranges. Operation outside these ranges may adversely affect reliability and could result in device failure.

No warranty is made with respect to uses, operating conditions, or combinations not represented on the data sheet. Users considering application outside the listed conditions are advised to contact their FUJITSU representatives beforehand.

- Processing and Protection of Pins

These precautions must be followed when handling the pins which connect semiconductor devices to power supply and input/output functions.

- (1) Preventing Over-Voltage and Over-Current Conditions

Exposure to voltage or current levels in excess of maximum ratings at any pin is likely to cause deterioration within the device, and in extreme cases leads to permanent damage of the device. Try to prevent such over voltage or over-current conditions at the design stage.

- (2) Protection of Output Pins

Shorting of output pins to supply pins or other output pins, or connection to large capacitance can cause large current flows. Such conditions if present for extended periods of time can damage the device. Therefore, avoid this type of connection.

- (3) Handling of Unused Input Pins

Unconnected input pins with very high impedance levels can adversely affect stability of operation. Such pins should be connected through an appropriate resistance to a power supply pin or ground pin.

- Latch-up

Semiconductor devices are constructed by the formation of P-type and N-type areas on a substrate. When subjected to abnormally high voltages, internal parasitic PNPN junctions (called thyristor structures) may be formed, causing large current levels in excess of several hundred mA to flow continuously at the power supply pin. This condition is called latch-up.

Note: The occurrence of latch-up not only causes loss of reliability in the semiconductor device, but can cause injury or damage from high heat, smoke or flame. To prevent this from happening, do the following:

- (a) Be sure that voltages applied to pins do not exceed the absolute maximum ratings. This should include attention to abnormal noise, surge levels, etc.
- (b) Be sure that abnormal current flows do not occur during the power-on sequence.

- Observance of Safety Regulations and Standards

Most countries in the world have established standards and regulations regarding safety, protection from electromagnetic interference, etc. Customers are requested to observe applicable regulations and standards in the design of products.

- Fail-Safe Design

Any semiconductor devices have inherently a certain rate of failure. You must protect against injury, damage or loss from such failures by incorporating safety design measures into your facility and equipment such as redundancy, fire protection, and prevention of over-current levels and other abnormal operating conditions.

- Precautions Related to Usage of Devices

FUJITSU semiconductor devices are intended for use in standard applications (computers, office automation and other office equipment, industrial, communications, and measurement equipment, personal or household devices, etc.).

CAUTION: Customers considering the use of our products in special applications where failure or abnormal operation may directly affect human lives or cause physical injury or property damage, or where extremely high levels of reliability are demanded (such as aerospace systems, atomic energy controls, submarine repeaters, vehicle operating controls, medical devices for life support, etc.) are requested to consult with FUJITSU sales representatives before such use. The company will not be responsible for damages arising from such use without prior approval.

## 2. Precautions for Package Mounting

Package mounting may be either lead insertion type or surface mounting type. In either case, quality assurance of heat resistance are applied for mounting under the Fujitsu's recommended conditions only at the soldering stage. For detailed information on mount conditions, contact the sales representative.

- Lead Insertion Type

Mounting of lead insertion type packages onto printed circuit boards may be done by two methods: direct soldering on the board, or mounting by using a socket.

Direct mounting onto boards normally involves processes for inserting leads into through-holes on the board and using the flow soldering (wave soldering) method of applying liquid solder.

In this case, the soldering process usually causes leads to be subjected to thermal stress in excess of the absolute ratings for storage temperature. Mounting processes should conform to FUJITSU recommended mounting conditions.

If socket mounting is used, differences in surface treatment of the socket contacts and IC lead surfaces can lead to contact deterioration after long periods. For this reason it is recommended that the surface treatment of socket contacts and IC leads be verified before mounting.

- Surface Mount Type

Surface mount packaging has longer and thinner leads than lead-insertion packaging, and therefore leads are more easily deformed or bent. The use of packages with higher pin counts and narrower pin pitch results in increased susceptibility to open connections caused by deformed pins, or shorting due to solder bridges.

You must use appropriate mounting techniques. FUJITSU recommends the solder reflow method, and has established a ranking of mounting conditions for each product. Users are advised to mount packages in accordance with FUJITSU ranking of recommended conditions.

- Storage of Semiconductor Devices

Because plastic chip packages are formed from plastic resins, exposure to natural environmental conditions will cause absorption of moisture. During mounting, the application of heat to a package that has absorbed moisture can cause surfaces to peel, reducing moisture resistance and causing packages to crack. To prevent, do the following:

- (a) Avoid exposure to rapid temperature changes, which cause moisture to condense inside the product. Store products in locations where temperature changes are slight.
- (b) Use dry boxes for product storage. Products should be stored below 70% relative humidity, and at temperatures between + 5 °C to + 30 °C.
- (c) When necessary, FUJITSU packages semiconductor devices in highly moisture-resistant aluminum laminate bags, with a silica gel desiccant. Devices should be sealed in their aluminum laminate bags for storage.
- (d) Avoid storing packages where they are exposed to corrosive gases or high levels of dust.

- Baking

Packages that have absorbed moisture may be de-moisturized by baking (heat drying). Follow the FUJITSU recommended conditions for baking.

- Static Electricity

Because semiconductor devices are particularly susceptible to damage by static electricity, you must take the following precautions:

- (a) Maintain relative humidity in the working environment between 40% and 70%. Use of an apparatus for ion generation may be needed to remove electricity.
- (b) Electrically ground all conveyors, solder vessels, soldering irons and peripheral equipment.
- (c) Eliminate static body electricity by the use of rings or bracelets connected to ground through high resistance (on the level of 1 MΩ). Wearing of conductive clothing and shoes, use of conductive floor mats and other measures to minimize shock loads is recommended.
- (d) Ground all fixtures and instruments, or protect with anti-static measures.
- (e) Avoid the use of styrofoam or other highly static-prone materials for storage of completed board assemblies.

### 3. Precautions for Use Environment

Reliability of semiconductor devices depends on ambient temperature and other conditions as described above. For reliable performance, do the following:

- (1) Humidity

Prolonged use in high humidity can lead to leakage in devices as well as printed circuit boards. If high humidity levels are anticipated, consider anti-humidity processing.

- (2) Discharge of Static Electricity

When high-voltage charges exist close to semiconductor devices, discharges can cause abnormal operation. In such cases, use anti-static measures or processing to prevent discharges.

- (3) Corrosive Gases, Dust, or Oil

Exposure to corrosive gases or contact with dust or oil may lead to chemical reactions that will adversely affect the device. If you use devices in such conditions, consider ways to prevent such exposure or to protect the devices.

- (4) Radiation, Including Cosmic Radiation

Most devices are not designed for environments involving exposure to radiation or cosmic radiation. Users should provide shielding as appropriate.

- (5) Smoke, Flame

Note: Plastic molded devices are flammable, and therefore should not be used near combustible substances. If devices begin to smoke or burn, there is danger of the release of toxic gases.

Customers considering the use of FUJITSU products in other special environmental conditions should consult with FUJITSU sales representatives.

## ■ HANDLING DEVICES

- Power supply pins

Because there are multiple VCC and VSS pins, respective pins at the same potential are interconnected to prevent malfunctions such as latch-up. However, you must connect the pins externally to the power supply and ground lines to reduce the electro-magnetic emission levels, to prevent abnormal operation of strobe signals caused by the rise in the ground level, and to conform to the total output current rating. Furthermore, the current supply source should be connected to the VCC and VSS pins of the device at a low impedance.

It is recommended to connect a ceramic bypass capacitor of approximately 0.1  $\mu$ F as a bypass capacitor between the V<sub>CC</sub> and V<sub>SS</sub> near this device.

- Crystal oscillator circuit

Noise in proximity to the X0 and X1 pins can cause the device to malfunction. Printed circuit boards should be designed so that the X0 and X1 pins, crystal oscillator (or ceramic oscillator), and bypass capacitors connected to ground are located near the device and ground.

It is recommended that the printed circuit board artwork be designed such that the X0 and X1 pins are surrounded by ground plane for the stable operation.

Please request the oscillator manufacturer to evaluate the oscillational characteristics of the crystal and this device.

- Mode pins (MD0 to MD3)

Connect them directly to VCC or VSS. To prevent the device from entering test mode accidentally due to noise, minimize the lengths of the patterns between each mode pin and VCC or VSS on the printed circuit board as much as possible and connect them at a low impedance. When used pulling down, design your circuit not to generate noises with a resistance 1 k $\Omega$  or less. Test your circuit and confirm that there is no problem.

- Operation at power-on

At power-on, it is necessary to make the terminal INITX “L” level.

Maintain the “L” level input to the INITX pin for the duration of the stabilization wait time immediately after the power on to ensure the stabilization wait time as required by the oscillator circuit.

- Note on oscillator input at power-on

At power-on, ensure that the clock is input until the oscillator stabilization wait time has elapsed.

- Built-in regulator

As this series includes built-in step-down regulators, always connect a bypass capacitor of 4.7  $\mu$ F or more to the C pin for use by the regulator.

- Notes on power on/off

Connect/disconnect the power supply pins when power on/off, or turn on/off in the following order.

Power on : VCC → AVCC, AVRH

Power off : AVCC, AVRH → VCC

- Precautions for the STOP mode

Set 1 to the bit 0 (OSCD1) of STCR register. When shifting to the STOP mode, a regulator switches to the stand-by regulator (for low-consumption current).

Due to the limited drive current, stop the (programming/erasing) access to the A/D converter and Flash before shifting to the STOP mode.

- Serial communication

There is a possibility to receive wrong data due to the noise or other causes on the serial communication. Therefore, design a board so as to avoid noise.

Retransmit the data if an error occurs because of applying the checksum to the last data in consideration of receiving wrong data due to the noise.

- Notes on using external clock

When using the external clock, as a general rule you should simultaneously supply X0 and X1 pins. And also, the clock signal to X0 should be supplied a clock signal with the reverse phase to X1 pins. However, in this case the stop mode (oscillation stop mode) must not be used.

- Example of using external clock (normal)

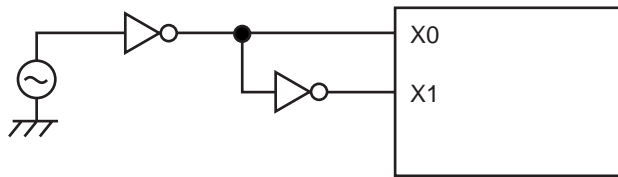

Note : Stop mode (oscillation stop mode) cannot be used.

- Notes on operating in PLL clock mode

If the oscillator is disconnected or the clock input stops when the PLL clock is selected, the microcontroller may continue to operate at the free-running frequency of the self-oscillating circuit of the PLL. However, this self-running operation cannot be guaranteed.

## ■ NOTES ON DEBUGGER

### • Execution of the RETI Command

If single-step execution is used in an environment where an interrupt occurs frequently, the corresponding interrupt handling routine will be executed repeatedly to the exclusion of other processing. This will prevent the main routine and the handlers for low priority level interrupts from being executed (For example, if the time-base timer interrupt is enabled, stepping over the RETI instruction will always break on the first line of the time-base timer interrupt handler).

Disable the corresponding interrupts when the corresponding interrupt handling routine no longer needs debugging.

### • Break function

If the range of addresses that cause a hardware break (including event breaks) is set to the address of the current system stack pointer or to an area that contains the stack pointer, execution will break after each instruction regardless of whether the user program actually contains data access instructions.

To prevent this, do not set (word) access to the area containing the address of the system stack pointer as the target of the hardware break (including an event breaks).

### • Operand break

It may cause malfunctions if a stack pointer exists in the area which is set as the DSU operand break. Do not set the access to the areas containing the address of system stack pointer as a target of data event break.

### • Notes on PS register

As the PS register is processed in advance by some instructions, when the debugger is being used, the following exception handling may result in execution breaking in an interrupt handling routine or the displayed values of the flags in the PS register being updated.

As the microcontroller is designed to carry out reprocessing correctly upon returning from such an EIT event, the operation before and after the EIT always proceeds according to specification.

1) The following behavior may occur if any of the following occurs in the instruction immediately after a DIV0U/DIV0S instruction:

(a) a user interrupt or NMI is accepted; (b) single-step execution is performed; or (c) execution breaks due to a data event or from the emulator menu.

-D0 and D1 flags are updated in advance.

-An EIT handling routine (user interrupt/NMI or emulator) is executed.

-Upon returning from the EIT, the DIV0U/DIV0S instruction is executed and the D0 and D1 flags are updated to the same values as those in 1).

2) The following behavior occurs when an ORCCR, STILM, MOV Ri or PS instruction is executed to enable a user interrupt or NMI source while that interrupt is in the active state.

-The PS register is updated in advance.

-An EIT handling routine (user interrupt/NMI or emulator) is executed.

-Upon returning from the EIT, the above instructions are executed and the PS register is updated to the same value as in 1).

## ■ BLOCK DIAGRAM

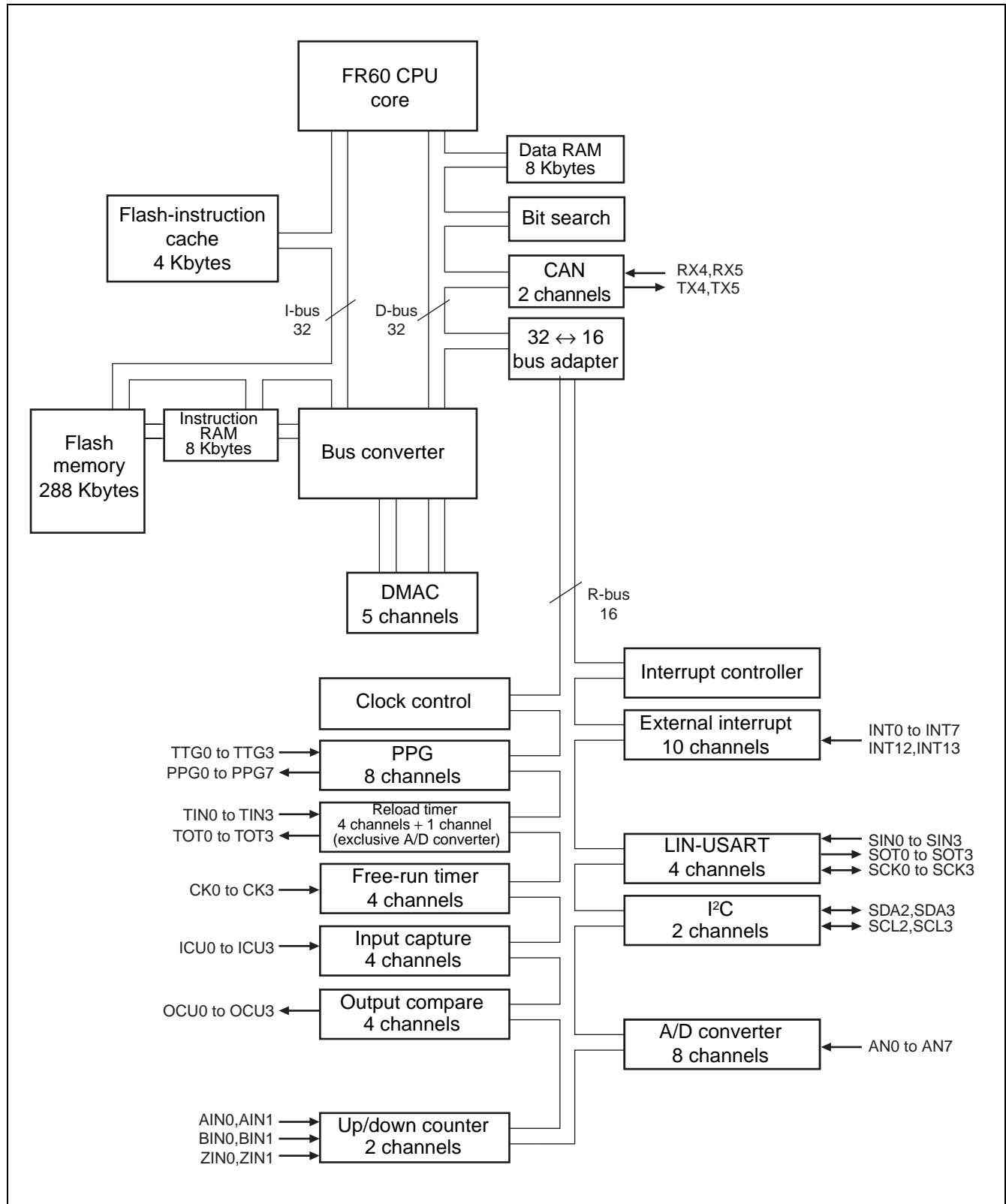

## ■ CPU AND CONTROL UNIT

### Internal architecture

The FR family CPU is a high performance core that is designed based on the RISC architecture with advanced instructions for embedded applications.

### 1. Features

- Adoption of RISC architecture  
Basic instruction: 1 instruction per cycle
- General-purpose registers: 32-bit × 16 registers
- 4 Gbytes linear memory space
- Multiplier installed  
32-bit × 32-bit multiplication: 5 cycles  
16-bit × 16-bit multiplication: 3 cycles
- Enhanced interrupt processing function  
Quick response speed (6 cycles)  
Multiple-interrupt support  
Level mask function (16 levels)
- Enhanced instructions for I/O operation  
Memory-to-memory transfer instruction  
Bit processing instruction
- Basic instruction word length: 16 bits
- Low-power consumption  
SLEEP mode/STOP mode

## 2. Internal architecture

The FR family CPU uses the Harvard architecture in which the instruction bus and data bus are independent of each other.

A 32-bit ↔ 16-bit bus adapter is connected to the 32-bit bus (D-bus) to provide an interface between the CPU and peripheral resources.

A Harvard ↔ Princeton bus converter is connected to both the I-bus and D-bus to provide an interface between the CPU and the bus controller.

The following figure shows the internal architecture structure.

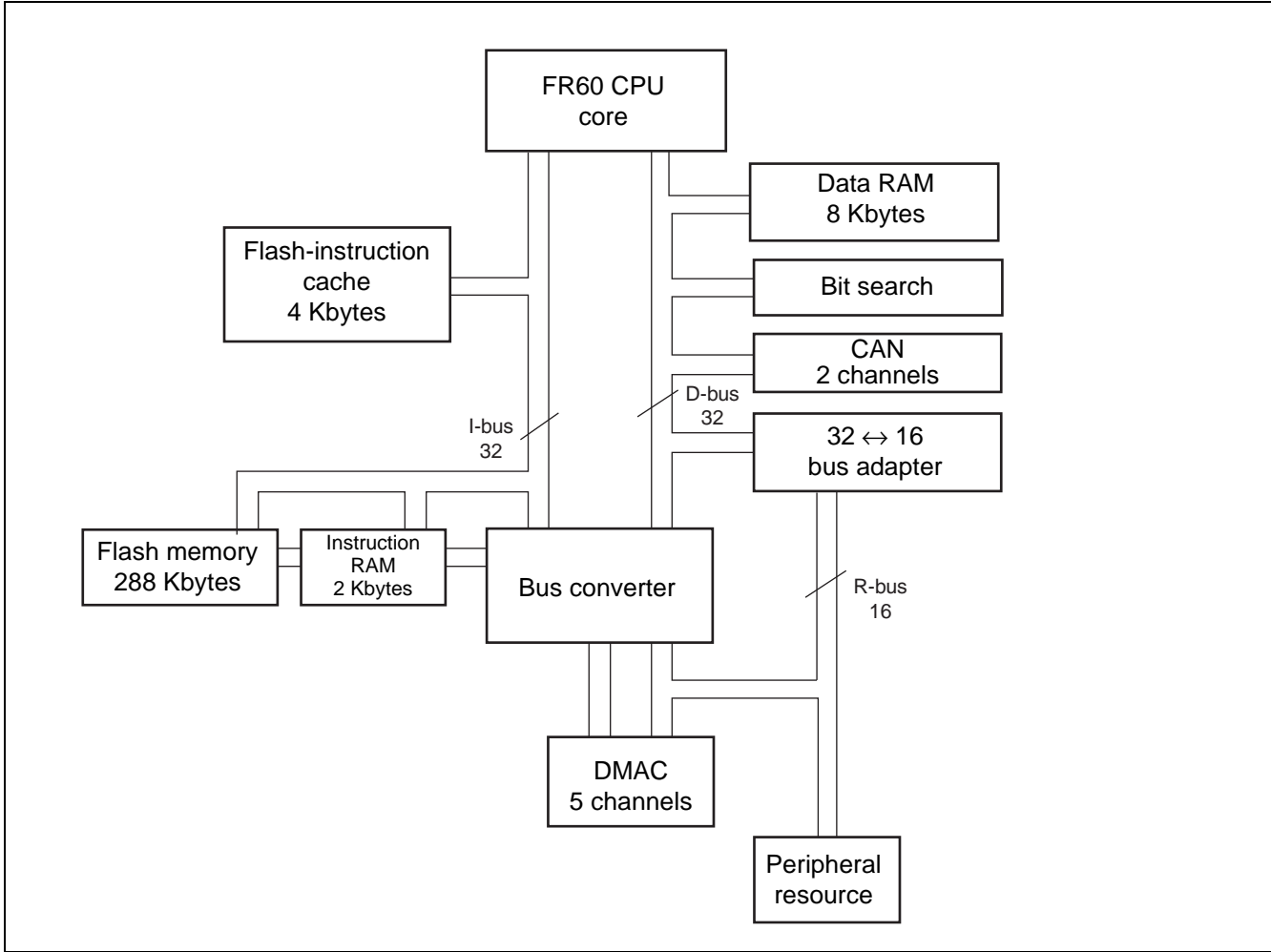

# MB91460N Series

## 3. Programming model

- Basic programming model

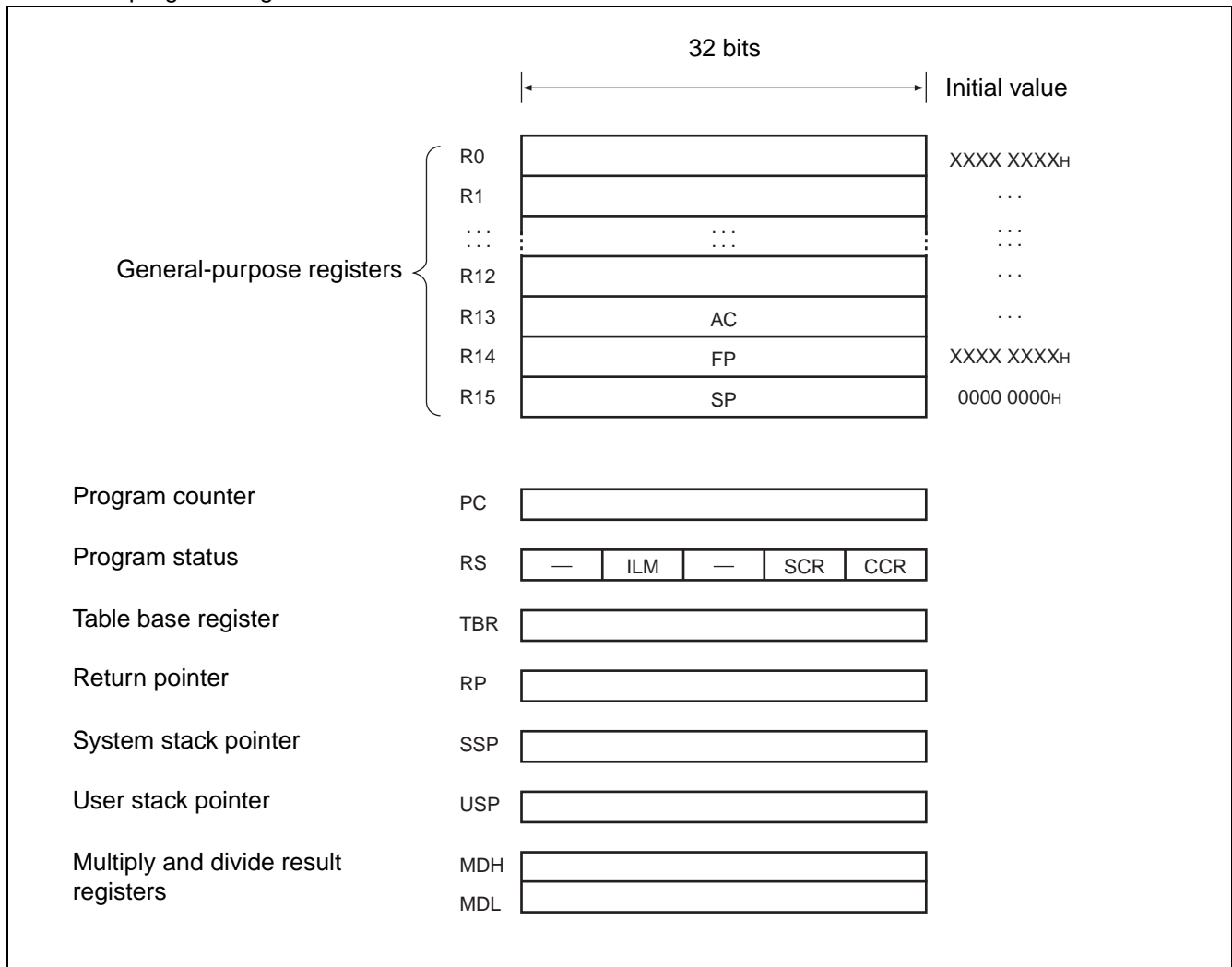

## 4. Registers

- General-purpose register

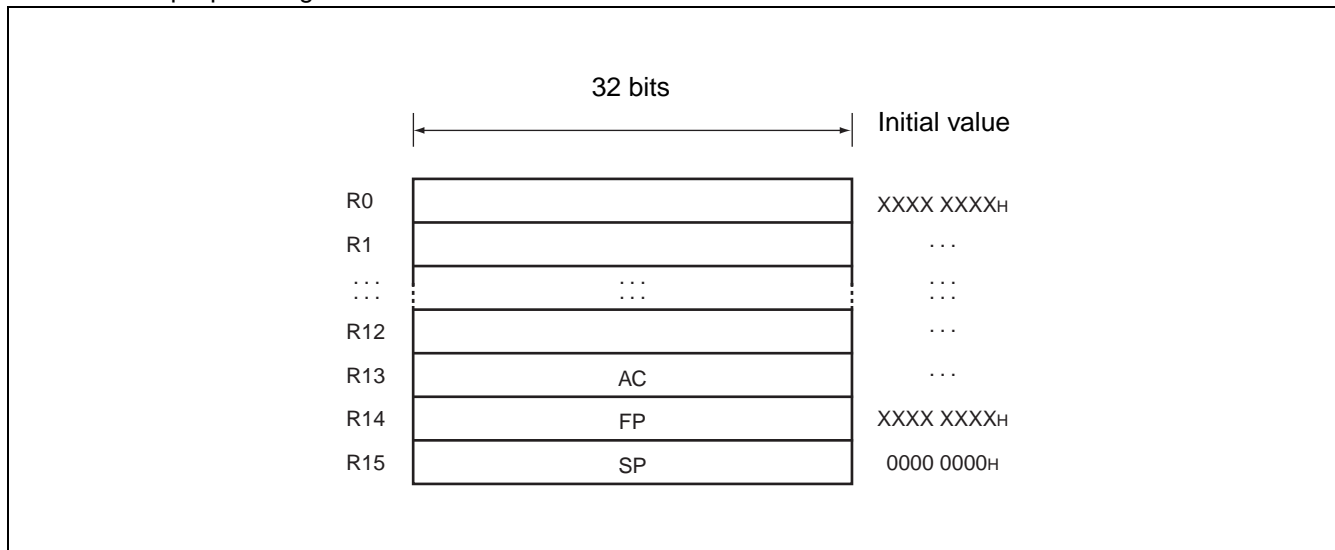

Registers R0 to R15 are general-purpose registers. These registers can be used as accumulators for computation operations and as pointers for memory access.

Enhanced commands are provided for some of the 16 registers to enable their use for particular applications.

R13 : Virtual accumulator

R14 : Frame pointer

R15 : Stack pointer

Initial values at reset are undefined for R0 to R14. The value for R15 is 00000000H (SSP value).

- PS (Program Status)

This register holds the program status, and is divided into three parts, ILM, SCR, and CCR.

All undefined bits (-) in the diagram are reserved bits. The values are always read "0". Write access to these bits is invalid.

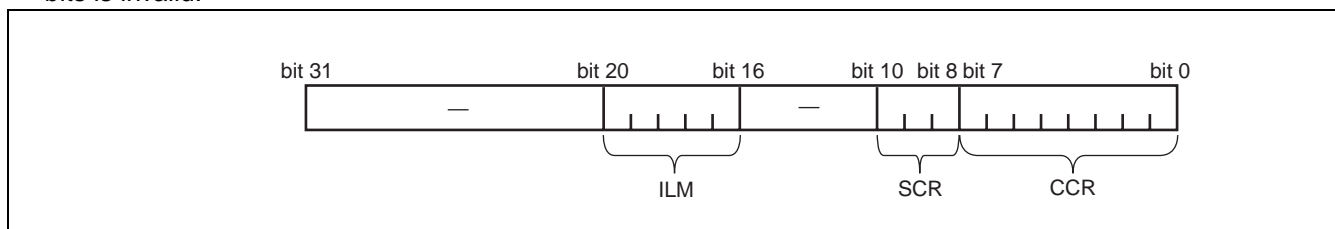

- CCR (Condition Code Register)

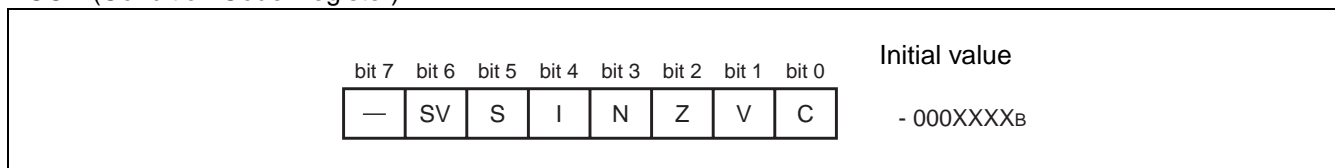

# MB91460N Series

- SV : Supervisor
- S : Stack flag
- I : Interrupt enable flag
- N : Negative enable flag
- Z : Zero flag
- V : Overflow flag
- C : Carry flag

## • SCR (System Condition Register)

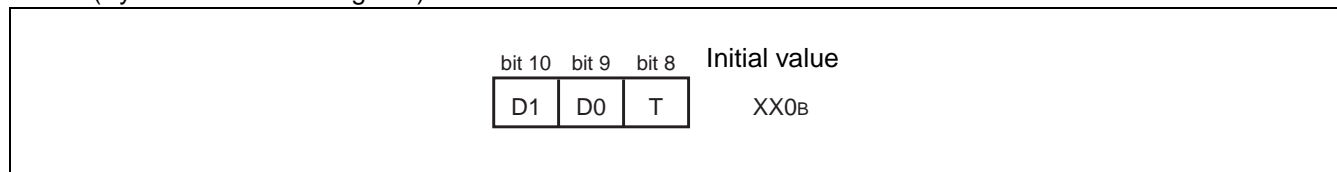

Flag for step multiplication (D1, D0)

This flag stores interim data during execution of step multiplication.

Step trace trap flag (T)

This flag indicates whether the step trace trap is enabled or disabled.

The step trace trap function is used by emulators. When an emulator is in use, it cannot be used in execution of user programs.

## • ILM

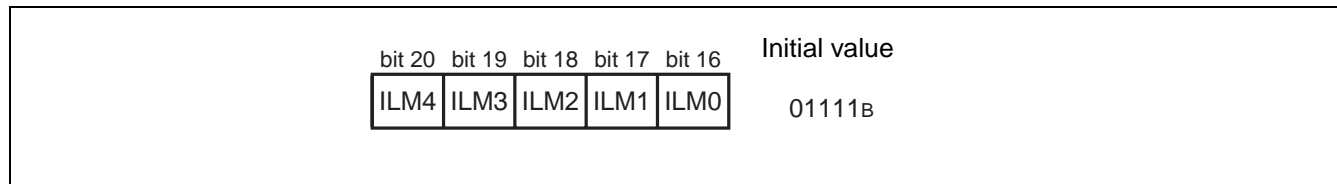

This register stores interrupt level mask values, and the values stored in ILM4 to ILM0 are used for level masking.

The register is initialized to value "01111<sub>B</sub>" at reset.

## • PC (Program Counter)

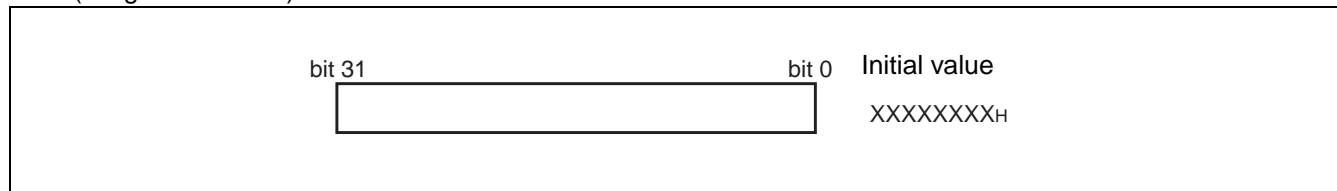

The program counter indicates the address of the instruction that is being executed.

The initial value at reset is undefined.

## • TBR (Table Base Register)

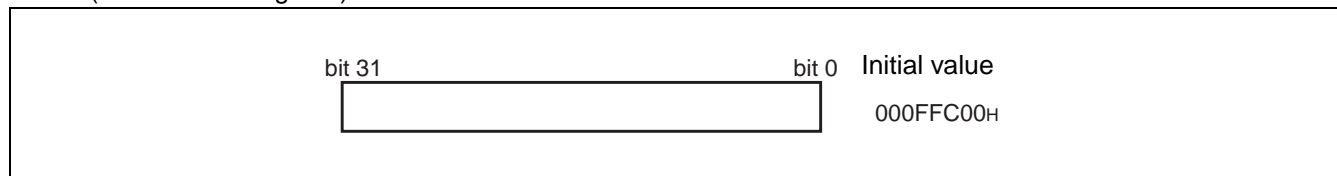

The table base register stores the starting address of the vector table used in EIT processing.

The initial value at reset is 000FFC00<sub>H</sub>.

- RP (Return Pointer)

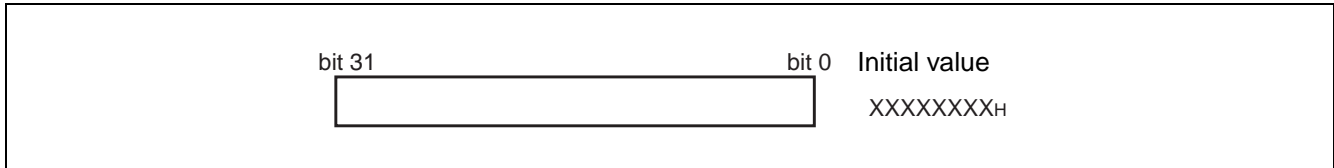

The return pointer stores the address to return from subroutines.

During execution of a CALL instruction, the PC value is transferred to this RP register.

During execution of a RET instruction, the contents of the RP register are transferred to PC.

The initial value at reset is undefined.

- USP (User Stack Pointer)

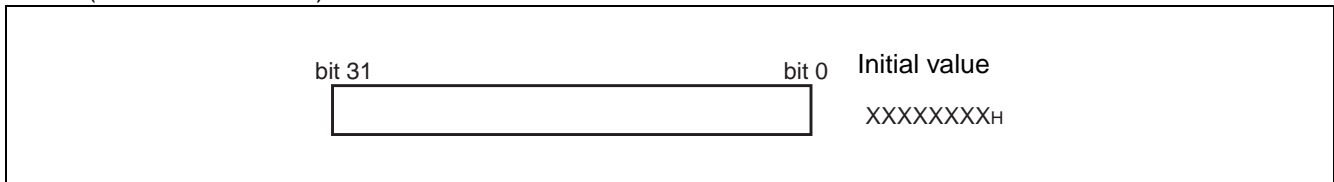

When the S flag is “1”, the user stack pointer functions as the R15 register.

- The USP register can also be explicitly specified.

The initial value at reset is undefined.

- This register cannot be used with RETI instructions.

- Multiply & divide registers

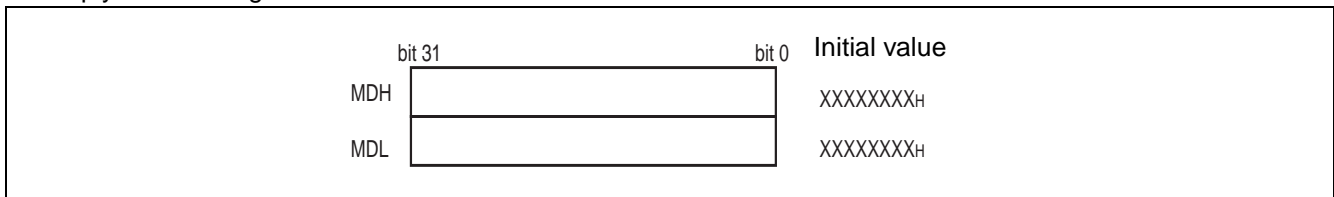

These registers are for multiplication and division, and are each 32 bits in length.

The initial value at reset is undefined.

# MB91460N Series

## ■ MODE SETTING

In the FR family, the mode pins (MD2, MD1, MD0) and the mode register (MODR) are used to set the operating mode.

### 1. Mode pins

The three pins MD2, MD1, MD0 are used to specify the mode vector fetch.

Settings other than shown in the table are prohibited.

Mode pins*			Mode name	Reset vector access area	Remarks
MD2	MD1	MD0			
0	0	0	Internal ROM mode vector	Internal	
0	0	1	External ROM mode vector	External	Not allowed

\* : Always use MD3 with "0".

### 2. Mode register (MODR)

The data written to the mode register using mode vector fetch is called mode data.

After the mode register (MODR) is set, the device operates according to the operation mode set in this register.

The mode register is set by all reset sources. User programs cannot write data to the mode register.

Rewriting is allowed in the emulator mode. In this case, use an 8-bit length data transfer instruction.

Data cannot be written by the transfer instruction of the 16/32-bit length.

Be sure to set these bits to "00000111<sub>B</sub>".

Operation is not guaranteed when any value other than "00000111<sub>B</sub>" is set.

Note : The mode data needs to be allocated in 000FFF8<sub>H</sub> as byte data. The mode data (00000111<sub>B</sub>) must be allocated in bit 31 to bit 24, as the FR family uses the big endian architecture.

## ■ RECOMMENDED SETTING

### 1. Setting of PLL and clock gear

Recommended setting of PLL division and clock gear

Clock input [MHz]	PLL multiplied setting		Clock gear setting		PLL (vco) output (X) [MHz]	Base clock [MHz]
	DIVM	DIVN	DIVG	MULG		
4	2	20	16	20	160	80
4	2	19	16	20	152	76
4	2	18	16	20	144	72
4	2	17	16	16	136	68
4	2	16	16	16	128	64
4	2	15	16	16	120	60
4	2	14	16	16	112	56
4	2	13	16	12	104	52
4	2	12	16	12	96	48
4	2	11	16	12	88	44
4	4	10	16	24	160	40
4	4	9	16	24	144	36
4	4	8	16	24	128	32
4	4	7	16	24	112	28
4	6	6	16	24	144	24
4	8	5	16	28	160	20
4	10	4	16	32	160	16
4	12	3	16	32	144	12

### 2. Setting of Flash memory controller

- Setting of flash access timing

For executing programs with a Flash memory, follow the settings below according to the frequency of CPU clock (CLKB). This setting is the most suitable for a high-speed access to the Flash memory.

At Flash memory read operating

CPU clock (CLKB)	ATD	ALEH	EQ	WEXH	WTC
To 24 MHz	0	0	0	0	1
To 48 MHz	0	0	1	0	2
To 80 MHz	1	1	3	0	4

At Flash memory write operating

CPU clock (CLKB)	ATD	ALEH	EQ	WEXH	WTC
To 32 MHz	1	0	1	0	4
To 48 MHz	1	0	3	0	5
To 64 MHz	1	1	3	0	6
To 80 MHz	1	1	3	0	7

# MB91460N Series

## 3. Setting of clock modulator

The setting values in the table are defined within the ranges of base clock frequency; 32 MHz to 80 MHz.  
 The Flash memory access needs to be configured according to the Fmax.  
 PLL and clock gear need to be configured according to the base clock.

Setting of clock modulator

Modulation (k)	Internal parameter (N)	CMPR [hex]	Base clock [MHz]	Fmin [MHz]	Fmax [MHz]
1	3	026F	80	72.6	89.1
1	3	026F	76	69.1	84.5
1	5	02AE	76	65.3	90.8
2	3	046E	76	65.3	90.8
1	3	026F	72	65.5	79.9
1	5	02AE	72	62	85.8
1	7	02ED	72	58.8	92.7
2	3	046E	72	62	85.8
1	3	026F	68	62	75.3
1	5	02AE	68	58.7	80.9
1	7	02ED	68	55.7	87.3
1	9	032C	68	53	95
2	3	046E	68	58.7	80.9
2	5	04AC	68	53	95
3	3	066D	68	55.7	87.3
4	3	086C	68	53	95
1	3	026F	64	58.5	70.7
1	5	02AE	64	55.3	75.9
1	7	02ED	64	52.5	82
1	9	032C	64	49.9	89.1
2	3	046E	64	55.3	75.9
2	5	04AC	64	49.9	89.1
3	3	066D	64	52.5	82
4	3	086C	64	49.9	89.1
1	3	026F	60	54.9	66.1
1	5	02AE	60	51.9	71
1	7	02ED	60	49.3	76.7
1	9	032C	60	46.9	83.3
2	3	046E	60	51.9	71
2	5	04AC	60	46.9	83.3
3	3	066D	60	49.3	76.7

(Continued)

# MB91460N Series

Modulation (k)	Internal parameter (N)	CMPR [hex]	Base clock [MHz]	Fmin [MHz]	Fmax [MHz]
4	3	086C	60	46.9	83.3
5	3	0A6B	60	44.7	91.3
1	3	026F	56	51.4	61.6
1	5	02AE	56	48.6	66.1
1	7	02ED	56	46.1	71.4
1	9	032C	56	43.8	77.6
1	11	036B	56	41.8	84.9
1	13	03AA	56	39.9	93.8
2	3	046E	56	48.6	66.1
2	5	04AC	56	43.8	77.6
2	7	04EA	56	39.9	93.8
3	3	066D	56	46.1	71.4
4	3	086C	56	43.8	77.6
5	3	0A6B	56	41.8	84.9
1	3	026F	52	47.8	57
1	5	02AE	52	45.2	61.2
1	7	02ED	52	42.9	66.1
1	9	032C	52	40.8	71.8
1	11	036B	52	38.8	78.6
1	13	03AA	52	37.1	86.8
2	3	046E	52	45.2	61.2
2	5	04AC	52	40.8	71.8
2	7	04EA	52	37.1	86.8
3	3	066D	52	42.9	66.1
3	5	06AA	52	37.1	86.8
4	3	086C	52	40.8	71.8
5	3	0A6B	52	38.8	78.6
6	3	0C6A	52	37.1	86.8
1	3	026F	48	44.2	52.5
1	5	02AE	48	41.8	56.4
1	7	02ED	48	39.6	60.9
1	9	032C	48	37.7	66.1
1	11	036B	48	35.9	72.3
1	13	03AA	48	34.3	79.9
1	15	03E9	48	32.8	89.1

(Continued)

# MB91460N Series

Modulation (k)	Internal parameter (N)	CMPR [hex]	Base clock [MHz]	Fmin [MHz]	Fmax [MHz]
2	3	046E	48	41.8	56.4
2	5	04AC	48	37.7	66.1
2	7	04EA	48	34.3	79.9
3	3	066D	48	39.6	60.9
3	5	06AA	48	34.3	79.9
4	3	086C	48	37.7	66.1
5	3	0A6B	48	35.9	72.3
6	3	0C6A	48	34.3	79.9
7	3	0E69	48	32.8	89.1
1	3	026F	44	40.6	48.1
1	5	02AE	44	38.4	51.6
1	7	02ED	44	36.4	55.7
1	9	032C	44	34.6	60.4
1	11	036B	44	33	66.1
1	13	03AA	44	31.5	73
1	15	03E9	44	30.1	81.4
2	3	046E	44	38.4	51.6
2	5	04AC	44	34.6	60.4
2	7	04EA	44	31.5	73
3	3	066D	44	36.4	55.7
3	5	06AA	44	31.5	73
4	3	086C	44	34.6	60.4
4	5	08A8	44	28.9	92.1
5	3	0A6B	44	33	66.1
6	3	0C6A	44	31.5	73
7	3	0E69	44	30.1	81.4
1	3	026F	40	37	43.6
1	5	02AE	40	34.9	46.8
1	7	02ED	40	33.1	50.5
1	9	032C	40	31.5	54.8
1	11	036B	40	30	59.9
1	13	03AA	40	28.7	66.1
1	15	03E9	40	27.4	73.7
2	3	046E	40	34.9	46.8
2	5	04AC	40	31.5	54.8

(Continued)

# MB91460N Series

Modulation (k)	Internal parameter (N)	CMPR [hex]	Base clock [MHz]	Fmin [MHz]	Fmax [MHz]
2	7	04EA	40	28.7	66.1
2	9	0528	40	26.3	83.3
3	3	066D	40	33.1	50.5
3	5	06AA	40	28.7	66.1
3	7	06E7	40	25.3	95.8
4	3	086C	40	31.5	54.8
4	5	08A8	40	26.3	83.3
5	3	0A6B	40	30	59.9
6	3	0C6A	40	28.7	66.1
7	3	0E69	40	27.4	73.7
8	3	1068	40	26.3	83.3
1	3	026F	36	33.3	39.2
1	5	02AE	36	31.5	42
1	7	02ED	36	29.9	45.3
1	9	032C	36	28.4	49.2
1	11	036B	36	27.1	53.8
1	13	03AA	36	25.8	59.3
1	15	03E9	36	24.7	66.1
2	3	046E	36	31.5	42
2	5	04AC	36	28.4	49.2
2	7	04EA	36	25.8	59.3
2	9	0528	36	23.7	74.7
3	3	066D	36	29.9	45.3
3	5	06AA	36	25.8	59.3
3	7	06E7	36	22.8	85.8
4	3	086C	36	28.4	49.2
4	5	08A8	36	23.7	74.7
5	3	0A6B	36	27.1	53.8
6	3	0C6A	36	25.8	59.3
7	3	0E69	36	24.7	66.1
8	3	1068	36	23.7	74.7
9	3	1267	36	22.8	85.8
1	3	026F	32	29.7	34.7
1	5	02AE	32	28	37.3
1	7	02ED	32	26.6	40.2

(Continued)

# MB91460N Series

(Continued)

Modulation (k)	Internal parameter (N)	CMPR [hex]	Base clock [MHz]	Fmin [MHz]	Fmax [MHz]
1	9	032C	32	25.3	43.6
1	11	036B	32	24.1	47.7
1	13	03AA	32	23	52.5
1	15	03E9	32	22	58.6
2	3	046E	32	28	37.3
2	5	04AC	32	25.3	43.6
2	7	04EA	32	23	52.5
2	9	0528	32	21.1	66.1
2	11	0566	32	19.5	89.1
3	3	066D	32	26.6	40.2
3	5	06AA	32	23	52.5
3	7	06E7	32	20.3	75.9
4	3	086C	32	25.3	43.6
4	5	08A8	32	21.1	66.1
5	3	0A6B	32	24.1	47.7
5	5	0AA6	32	19.5	89.1
6	3	0C6A	32	23	52.5
7	3	0E69	32	22	58.6
8	3	1068	32	21.1	66.1
9	3	1267	32	20.3	75.9
10	3	1466	32	19.5	89.1

## ■ MEMORY SPACE

### 1. Memory space

The FR family has 4 Gbytes of logical address space ( $2^{32}$  addresses) available to the CPU by linear access.

- Direct addressing area

The following address space area is used for I/O.

This area is called direct addressing area, and the address of an operand can be specified directly in an instruction.

The size of directly addressable area depends on the length of the data to be accessed as shown below.

Byte data access : 000<sub>H</sub> to 0FF<sub>H</sub>

Half word access : 000<sub>H</sub> to 1FF<sub>H</sub>

Word data access : 000<sub>H</sub> to 3FF<sub>H</sub>

# MB91460N Series

## 2. Memory map

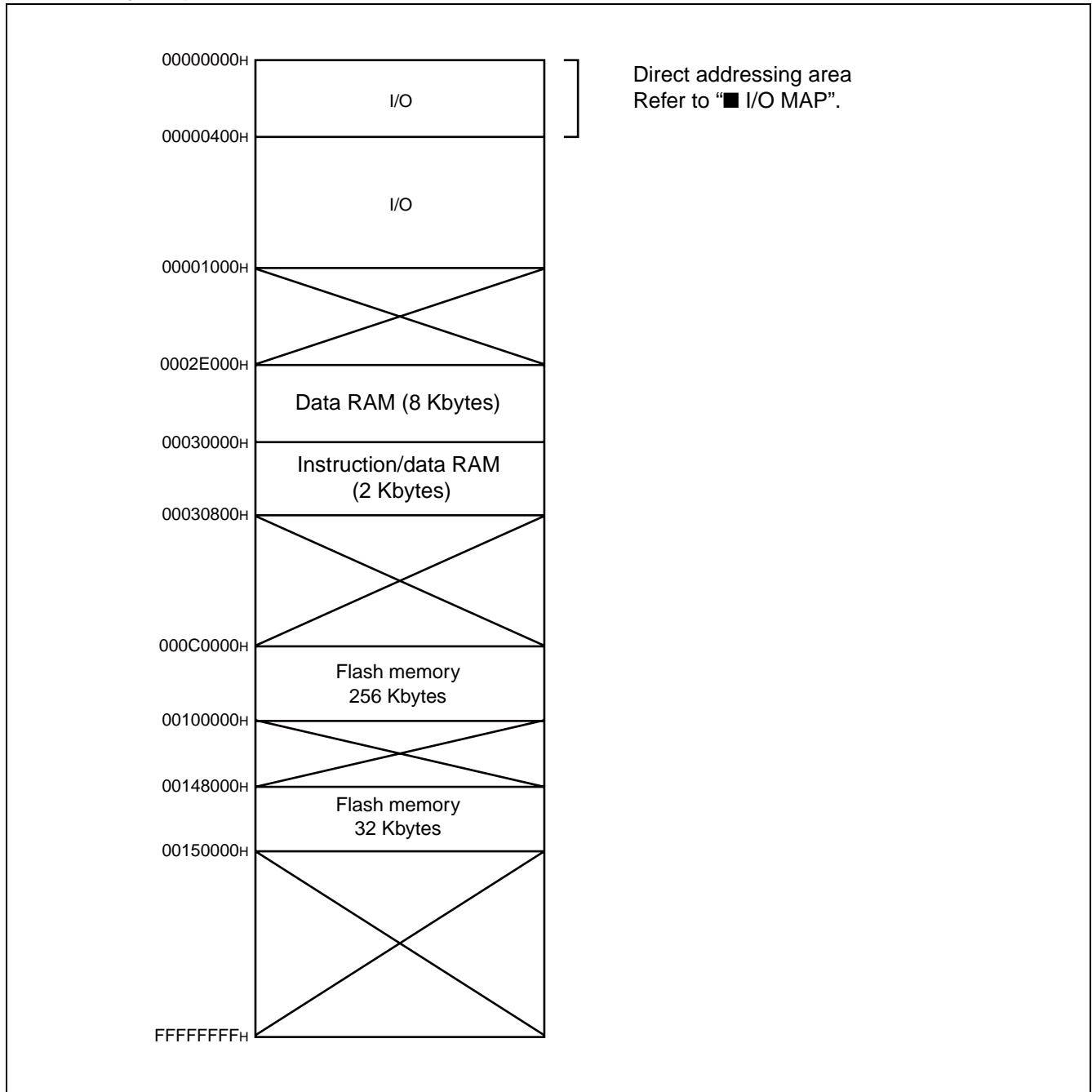

## ■ I/O MAP

Address	Register				Block
	+ 0	+ 1	+ 2	+ 3	
000000H	PDR0 [R/W] XXXXXXXX	PDR1 [R/W] XXXXXXXX	PDR2 [R/W] XXXXXXXX	PDR3 [R/W] XXXXXXXX	T-unit port data register

Read/write attribute

Initial value of register after reset

Register name (column 1 register at address 4n, column 2 register at address 4n + 1...)

Leftmost register address (for word access, the register in column 1 is the MSB side of the data.)

Note : Initial values of register bits are represented as follows:

“ 1 ” : Initial value “ 1 ”

“ 0 ” : Initial value “ 0 ”

“ X ” : Initial value “ undefined ”

“ - ” : No physical register at this location

Access is prohibited to areas where the data access attributes are undefined.

# MB91460N Series

Address	Register				Block
	+0	+1	+2	+3	
000000 <sub>H</sub> to 000008 <sub>H</sub>	Reserved				R-bus Port Data Register
00000C <sub>H</sub>	Reserved		PDR14 [R/W] ---- XXXX	PDR15 [R/W] ---- XXXX	
000010 <sub>H</sub>	Reserved	PDR17 [R/W] XXXXXXXX	Reserved		
000014 <sub>H</sub>	PDR20 [R/W] -XXX-XXX	PDR21 [R/W] -XXX-XXX	PDR22 [R/W] ---- XXXX	Reserved	
000018 <sub>H</sub>	PDR24 [R/W] XXXXXXXX	Reserved			
00001C <sub>H</sub>	Reserved	PDR29 [R/W] XXXXXXXX	Reserved		
000020 <sub>H</sub>	Reserved				
000024 <sub>H</sub> to 00002C <sub>H</sub>	Reserved				Reserved
000030 <sub>H</sub>	EIRR0 [R/W] 00000000	ENIR0 [R/W] 00000000	ELVR0 [R/W] 00000000 00000000		External interrupt 0 to 7
000034 <sub>H</sub>	EIRR1 [R/W] 00000000	ENIR1 [R/W] 00000000	ELVR1 [R/W] 00000000 00000000		External interrupt 12, 13
000038 <sub>H</sub>	DICR [R/W] ----- 0	HRCL [R/W] 0 -- 11111	Reserved		DLYI/I-unit
00003C <sub>H</sub>	Reserved				Reserved
000040 <sub>H</sub>	SCR00 [R/W, W] 00000000	SMR00 [R/W, W] 00000000	SSR00 [R/W, R] 00001000	RDR00/TDR00 [R/W] 00000000	LIN-USART0
000044 <sub>H</sub>	ESCR00 [R/W] 00000X00	ECCR00 [R/W, R, W] 000000XX	Reserved		
000048 <sub>H</sub>	SCR01 [R/W, W] 00000000	SMR01 [R/W, W] 00000000	SSR01 [R/W, R] 00001000	RDR01/TDR01 [R/W] 00000000	LIN-USART1
00004C <sub>H</sub>	ESCR01 [R/W] 00000X00	ECCR01 [R/W, R, W] 000000XX	Reserved		
000050 <sub>H</sub>	SCR02 [R/W, W] 00000000	SMR02 [R/W, W] 00000000	SSR02 [R/W, R] 00001000	RDR02/TDR02 [R/W] 00000000	LIN-USART2
000054 <sub>H</sub>	ESCR02 [R/W] 00000X00	ECCR02 [R/W, R, W] 000000XX	Reserved		

(Continued)

# MB91460N Series

Address	Register				Block
	+0	+1	+2	+3	
000058 <sub>H</sub>	SCR03 [R/W, W] 00000000	SMR03 [R/W, W] 00000000	SSR03 [R/W, R] 00001000	RDR03/TDR03 [R/W] 00000000	LIN-USART3
00005C <sub>H</sub>	ESCR03 [R/W] 00000X00	ECCR03 [R/W, R, W] 000000XX	Reserved		
000060 <sub>H</sub> to 00007C <sub>H</sub>	Reserved				Reserved
000080 <sub>H</sub>	BGR100 [R/W] 00000000	BGR000 [R/W] 00000000	BGR101 [R/W] 00000000	BGR001 [R/W] 00000000	Baud rate Generator LIN-USART0 to 3
000084 <sub>H</sub>	BGR102 [R/W] 00000000	BGR002 [R/W] 00000000	BGR103 [R/W] 00000000	BGR003 [R/W] 00000000	
000088 <sub>H</sub> , 00008C <sub>H</sub>	Reserved				
000090 <sub>H</sub> to 0000FC <sub>H</sub>	Reserved				Reserved
000100 <sub>H</sub>	GCN10 [R/W] 00110010 00010000		Reserved	GCN20 [R/W] ---- 0000	PPG Control 0 to 3
000104 <sub>H</sub>	GCN11 [R/W] 00110010 00010000		Reserved	GCN21 [R/W] ---- 0000	PPG Control 4 to 7
000108 <sub>H</sub>	Reserved				Reserved
000110 <sub>H</sub>	PTMR00 [R] 11111111 11111111		PCSR00 [W] XXXXXXXX XXXXXXXX		PPG 0
000114 <sub>H</sub>	PDUT00 [W] XXXXXXXX XXXXXXXX		PCNH00 [R/W] 0000000 -	PCNL00 [R/W] 000000 - 0	
000118 <sub>H</sub>	PTMR01 [R] 11111111 11111111		PCSR01 [W] XXXXXXXX XXXXXXXX		PPG 1
00011C <sub>H</sub>	PDUT01 [W] XXXXXXXX XXXXXXXX		PCNH01 [R/W] 0000000 -	PCNL01 [R/W] 000000 - 0	
000120 <sub>H</sub>	PTMR02 [R] 11111111 11111111		PCSR02 [W] XXXXXXXX XXXXXXXX		PPG 2
000124 <sub>H</sub>	PDUT02 [W] XXXXXXXX XXXXXXXX		PCNH02 [R/W] 0000000 -	PCNL02 [R/W] 000000 - 0	

(Continued)

# MB91460N Series

Address	Register				Block
	+0	+1	+2	+3	
000128 <sub>H</sub>	PTMR03 [R] 11111111 11111111		PCSR03 [W] XXXXXXXX XXXXXXXX		PPG 3
00012C <sub>H</sub>	PDUT03 [W] XXXXXXXX XXXXXXXX		PCNH03 [R/W] 0000000 -	PCNL03 [R/W] 000000 - 0	
000130 <sub>H</sub>	PTMR04 [R] 11111111 11111111		PCSR04 [W] XXXXXXXX XXXXXXXX		PPG 4
000134 <sub>H</sub>	PDUT04 [W] XXXXXXXX XXXXXXXX		PCNH04 [R/W] 0000000 -	PCNL04 [R/W] 000000 - 0	
000138 <sub>H</sub>	PTMR05 [R] 11111111 11111111		PCSR05 [W] XXXXXXXX XXXXXXXX		PPG 5
00013C <sub>H</sub>	PDUT05 [W] XXXXXXXX XXXXXXXX		PCNH05 [R/W] 0000000 -	PCNL05 [R/W] 000000 - 0	
000140 <sub>H</sub>	PTMR06 [R] 11111111 11111111		PCSR06 [W] XXXXXXXX XXXXXXXX		PPG 6
000144 <sub>H</sub>	PDUT06 [W] XXXXXXXX XXXXXXXX		PCNH06 [R/W] 0000000 -	PCNL06 [R/W] 000000 - 0	
000148 <sub>H</sub>	PTMR07 [R] 11111111 11111111		PCSR07 [W] XXXXXXXX XXXXXXXX		PPG 7
00014C <sub>H</sub>	PDUT07 [W] XXXXXXXX XXXXXXXX		PCNH07 [R/W] 0000000 -	PCNL07 [R/W] 000000 - 0	
000150 <sub>H</sub> to 00017C <sub>H</sub>	Reserved				Reserved
000180 <sub>H</sub>	Reserved	ICS01 [R/W] 00000000	Reserved	ICS23 [R/W] 00000000	Input Capture 0 to 3
000184 <sub>H</sub>	IPCP0 [R] XXXXXXXX XXXXXXXX		IPCP1 [R] XXXXXXXX XXXXXXXX		
000188 <sub>H</sub>	IPCP2 [R] XXXXXXXX XXXXXXXX		IPCP3 [R] XXXXXXXX XXXXXXXX		
00018C <sub>H</sub>	OCS01 [R/W] --- 0 -- 00 0000 -- 00		OCS23 [R/W] --- 0 -- 00 0000 -- 00		Output Compare 0 to 3
000190 <sub>H</sub>	OCCP0 [R/W] XXXXXXXX XXXXXXXX		OCCP1 [R/W] XXXXXXXX XXXXXXXX		
000194 <sub>H</sub>	OCCP2 [R/W] XXXXXXXX XXXXXXXX		OCCP3 [R/W] XXXXXXXX XXXXXXXX		
000198 <sub>H</sub> , 00019C <sub>H</sub>	Reserved				Reserved

(Continued)

# MB91460N Series

Address	Register				Block
	+0	+1	+2	+3	
0001A0 <sub>H</sub>	Reserved			ADERL [R/W] 00000000	A/D Converter
0001A4 <sub>H</sub>	ADCS1 [R/W] 00000000	ADCS0 [R/W] 00000000	ADCR1 [R] 000000XX	ADCR0 [R] XXXXXXXXXX	
0001A8 <sub>H</sub>	ADCT1 [R/W] 00010000	ADCT0 [R/W] 00101100	ADSCH [R/W] - - - 00000	ADECH [R/W] - - - 00000	
0001AC <sub>H</sub>	Reserved				Reserved
0001B0 <sub>H</sub>	TMRLR0 [W] XXXXXXXXXX XXXXXXXXXX		TMR0 [R] XXXXXXXXXX XXXXXXXXXX		Reload Timer 0  (PPG0, PPG1)
0001B4 <sub>H</sub>	Reserved		TMCSRH0 [R/W] - - - 00000	TMCSRL0 [R/W] 0 - 000000	
0001B8 <sub>H</sub>	TMRLR1 [W] XXXXXXXXXX XXXXXXXXXX		TMR1 [R] XXXXXXXXXX XXXXXXXXXX		Reload Timer 1  (PPG2, PPG3)
0001BC <sub>H</sub>	Reserved		TMCSRH1 [R/W] - - - 00000	TMCSRL1 [R/W] 0 - 000000	
0001C0 <sub>H</sub>	TMRLR2 [W] XXXXXXXXXX XXXXXXXXXX		TMR2 [R] XXXXXXXXXX XXXXXXXXXX		Reload Timer 2  (PPG4, PPG5)
0001C4 <sub>H</sub>	Reserved		TMCSRH2 [R/W] - - - 00000	TMCSRL2 [R/W] 0 - 000000	
0001C8 <sub>H</sub>	TMRLR3 [W] XXXXXXXXXX XXXXXXXXXX		TMR3 [R] XXXXXXXXXX XXXXXXXXXX		Reload Timer 3  (PPG6, PPG7)
0001CC <sub>H</sub>	Reserved		TMCSRH3 [R/W] - - - 00000	TMCSRL3 [R/W] 0 - 000000	
0001D0 <sub>H</sub> to 0001E7 <sub>H</sub>	Reserved				Reserved
0001E8 <sub>H</sub>	TMRLR7 [W] XXXXXXXXXX XXXXXXXXXX		TMR7 [R] XXXXXXXXXX XXXXXXXXXX		Reload Timer 7 (A/D converter)
0001EC <sub>H</sub>	Reserved		TMCSRH7 [R/W] - - - 00000	TMCSRL7 [R/W] 0 - 000000	
0001F0 <sub>H</sub>	TCDT0 [R/W] XXXXXXXXXX XXXXXXXXXX		Reserved	TCCS0 [R/W] 00000000	Free-run Timer 0 (ICU0, ICU1)

(Continued)

# MB91460N Series

Address	Register				Block	
	+0	+1	+2	+3		
0001F4 <sub>H</sub>	TCDT1 [R/W] XXXXXXXX XXXXXXXX		Reserved	TCCS1 [R/W] 00000000	Free-run Timer 1 (ICU2, ICU3)	
0001F8 <sub>H</sub>	TCDT2 [R/W] XXXXXXXX XXXXXXXX		Reserved	TCCS2 [R/W] 00000000	Free-run Timer 2 (OCU0, OCU1)	
0001FC <sub>H</sub>	TCDT3 [R/W] XXXXXXXX XXXXXXXX		Reserved	TCCS3 [R/W] 00000000	Free-run Timer 3 (OCU2, OCU3)	
000200 <sub>H</sub>	DMACA0 [R/W] * 00000000 0000XXXX XXXXXXXX XXXXXXXX				DMAC	
000204 <sub>H</sub>	DMACB0 [R/W] 00000000 00000000 XXXXXXXX XXXXXXXX					
000208 <sub>H</sub>	DMACA1 [R/W] * 00000000 0000XXXX XXXXXXXX XXXXXXXX					
00020C <sub>H</sub>	DMACB1 [R/W] 00000000 00000000 XXXXXXXX XXXXXXXX					
000210 <sub>H</sub>	DMACA2 [R/W] * 00000000 0000XXXX XXXXXXXX XXXXXXXX					
000214 <sub>H</sub>	DMACB2 [R/W] 00000000 00000000 XXXXXXXX XXXXXXXX					
000218 <sub>H</sub>	DMACA3 [R/W] * 00000000 0000XXXX XXXXXXXX XXXXXXXX					
00021C <sub>H</sub>	DMACB3 [R/W] 00000000 00000000 XXXXXXXX XXXXXXXX					
000220 <sub>H</sub>	DMACA4 [R/W] * 00000000 0000XXXX XXXXXXXX XXXXXXXX					
000224 <sub>H</sub>	DMACB4 [R/W] 00000000 00000000 XXXXXXXX XXXXXXXX					
000228 <sub>H</sub> to 00023C <sub>H</sub>	Reserved					
000240 <sub>H</sub>	DMACR [R/W] 0- - - 0000	Reserved				
000244 <sub>H</sub> to 0002FC <sub>H</sub>	Reserved					Reserved
000300 <sub>H</sub>	UDRC1 [W] 00000000	UDRC0 [W] 00000000	UDCR1 [R] 00000000	UDCR0 [R] 00000000		Up/Down Counter 0, 1
000304 <sub>H</sub>	UDCCH0 [R/W] 00000000	UDCCL0 [R/W] 00001000	Reserved	UDCS0 [R/W] 00000000		
000308 <sub>H</sub>	UDCCH1 [R/W] 00000000	UDCCL1 [R/W] 00001000	Reserved	UDCS1 [R/W] 00000000		
00030C <sub>H</sub> to 000364 <sub>H</sub>	Reserved				Reserved	

(Continued)

# MB91460N Series

Address	Register				Block
	+0	+1	+2	+3	
000368 <sub>H</sub>	IBCR2 [R/W] 00000000	IBSR2 [R] 00000000	ITBAH2 [R/W] -----00	ITBAL2 [R/W] 00000000	I <sup>2</sup> C 2
00036C <sub>H</sub>	ITMKH2 [R/W] 00----11	ITMKL2 [R/W] 11111111	ISMK2 [R/W] 01111111	ISBA2 [R/W] -0000000	
000370 <sub>H</sub>	Reserved	IDAR2 [R/W] 00000000	ICCR2 [R/W] -0011111	Reserved	
000374 <sub>H</sub>	IBCR3 [R/W] 00000000	IBSR3 [R] 00000000	ITBAH3 [R/W] -----00	ITBAL3 [R/W] 00000000	I <sup>2</sup> C 3
000378 <sub>H</sub>	ITMKH3 [R/W] 00----11	ITMKL3 [R/W] 11111111	ISMK3 [R/W] 01111111	ISBA3 [R/W] -0000000	
00037C <sub>H</sub>	Reserved	IDAR3 [R/W] 00000000	ICCR3 [R/W] -0011111	Reserved	
000380 <sub>H</sub> to 00038C <sub>H</sub>	Reserved				Reserved
000390 <sub>H</sub>	ROMS [R] 11111111 01001111		Reserved		ROM Select Register
000394 <sub>H</sub> to 0003EC <sub>H</sub>	Reserved				Reserved
0003F0 <sub>H</sub>	BSD0 [W] XXXXXXXX XXXXXXXX XXXXXXXX XXXXXXXX				Bit Search Module
0003F4 <sub>H</sub>	BSD1 [R/W] XXXXXXXX XXXXXXXX XXXXXXXX XXXXXXXX				
0003F8 <sub>H</sub>	BSDC [W] XXXXXXXX XXXXXXXX XXXXXXXX XXXXXXXX				
0003FC <sub>H</sub>	BSRR [R] XXXXXXXX XXXXXXXX XXXXXXXX XXXXXXXX				
000400 <sub>H</sub> to 00043C <sub>H</sub>	Reserved				Reserved
000440 <sub>H</sub>	ICR00 [R/W] ---11111	ICR01 [R/W] ---11111	ICR02 [R/W] ---11111	ICR03 [R/W] ---11111	Interrupt Control Unit
000444 <sub>H</sub>	ICR04 [R/W] ---11111	ICR05 [R/W] ---11111	ICR06 [R/W] ---11111	ICR07 [R/W] ---11111	
000448 <sub>H</sub>	ICR08 [R/W] ---11111	ICR09 [R/W] ---11111	ICR10 [R/W] ---11111	ICR11 [R/W] ---11111	
00044C <sub>H</sub>	ICR12 [R/W] ---11111	ICR13 [R/W] ---11111	ICR14 [R/W] ---11111	ICR15 [R/W] ---11111	
000450 <sub>H</sub>	ICR16 [R/W] ---11111	ICR17 [R/W] ---11111	ICR18 [R/W] ---11111	ICR19 [R/W] ---11111	

(Continued)

# MB91460N Series

Address	Register				Block
	+0	+1	+2	+3	
000454 <sub>H</sub>	ICR20 [R/W] --- 11111	ICR21 [R/W] --- 11111	ICR22 [R/W] --- 11111	ICR23 [R/W] --- 11111	Interrupt Control Unit
000458 <sub>H</sub>	ICR24[R/W] --- 11111	ICR25[R/W] --- 11111	ICR26[R/W] --- 11111	ICR27[R/W] --- 11111	
00045C <sub>H</sub>	ICR28[R/W] --- 11111	ICR29 [R/W] --- 11111	ICR30[R/W] --- 11111	ICR31[R/W] --- 11111	
000460 <sub>H</sub>	ICR32[R/W] --- 11111	ICR33[R/W] --- 11111	ICR34[R/W] --- 11111	ICR35[R/W] --- 11111	
000464 <sub>H</sub>	ICR36[R/W] --- 11111	ICR37[R/W] --- 11111	ICR38 [R/W] --- 11111	ICR39 [R/W] --- 11111	
000468 <sub>H</sub>	ICR40[R/W] --- 11111	ICR41[R/W] --- 11111	ICR42 [R/W] --- 11111	ICR43 [R/W] --- 11111	
00046C <sub>H</sub>	ICR44[R/W] --- 11111	ICR45[R/W] --- 11111	ICR46[R/W] --- 11111	ICR47[R/W] --- 11111	
000470 <sub>H</sub>	ICR48 [R/W] --- 11111	ICR49 [R/W] --- 11111	ICR50 [R/W] --- 11111	ICR51 [R/W] --- 11111	
000474 <sub>H</sub>	ICR52[R/W] --- 11111	ICR53[R/W] --- 11111	ICR54[R/W] --- 11111	ICR55[R/W] --- 11111	
000478 <sub>H</sub>	ICR56 [R/W] --- 11111	ICR57[R/W] --- 11111	ICR58 [R/W] --- 11111	ICR59 [R/W] --- 11111	
00047C <sub>H</sub>	ICR60[R/W] --- 11111	ICR61 [R/W] --- 11111	ICR62 [R/W] --- 11111	ICR63 [R/W] --- 11111	
000480 <sub>H</sub>	RSRR [R/W] 10000000	STCR [R/W] 001100-1	TBCR [R/W] 00XXXX00	CTBR [W] XXXXXXXXXX	
000484 <sub>H</sub>	CLKR [R/W] ----- 000	WPR [W] XXXXXXXXXX	DIVR0 [R/W] 00000011	DIVR1 [R/W] 00000000	
000488 <sub>H</sub>	Reserved				Reserved
00048C <sub>H</sub>	PLLDIVM [R/W] ---- 0000	PLLDIVN [R/W] -- 000000	PLLDIVG [R/W] ---- 0000	PLLMULG [R/W] 00000000	PLL Clock Gear Unit
000490 <sub>H</sub>	PLLCTRL [R/W] ---- 0000	Reserved			
000494 <sub>H</sub>	Reserved				Reserved
000498 <sub>H</sub>	PORTEN [R/W] ----- 00	Reserved			Port Input Enable Control
00049C <sub>H</sub>	Reserved				Reserved

(Continued)

# MB91460N Series

Address	Register				Block
	+0	+1	+2	+3	
0004A0 <sub>H</sub>	Reserved	WTCER [R/W] ----- 00	WTCR [R/W] 00000000 000 - 00 - 0		Real Time Clock (Watch Timer)
0004A4 <sub>H</sub>	Reserved	WTBR [R/W] --- XXXXX XXXXXXXX XXXXXXXX			
0004A8 <sub>H</sub>	WTHR [R/W] --- 00000	WTMR [R/W] -- 000000	WTSR [R/W] -- 000000	Reserved	
0004AC <sub>H</sub>	Reserved		CSCFG [R/W] 0X000000	CMCFG [R/W] 00000000	Clock Monitor
0004B0 <sub>H</sub> , 0004B4 <sub>H</sub>	Reserved				Reserved
0004B8 <sub>H</sub>	CMPR [R/W] -- 000010 11111101		Reserved	CMCR [R/W] - 001 -- 00	Clock Modulator
0004BC <sub>H</sub>	CMT1 [R/W] 00000000 1 --- 0000		CMT2 [R/W] -- 000000 -- 000000		
0004C0 <sub>H</sub>	CANPRE [R/W] 00000000	CANCKD [R/W] -- 00 ----	Reserved		CAN Clock Control
0004C4 <sub>H</sub>	Reserved	LVDET [R/W] 00000 - 00	HWWDE [R/W] ----- 00	HWWD [R/W, W] 00011000	Low-voltage Detection
0004C8 <sub>H</sub>	OSCRH [R/W] 000 -- 001	OSCR [R/W] ----- 000	Reserved		Main- Oscillation Stabilization Timer
0004CC <sub>H</sub>	Reserved				
0004D0 <sub>H</sub> to 0007F8 <sub>H</sub>	Reserved				
0007FC <sub>H</sub>	Reserved	MODR [W] XXXXXXXX	Reserved		Mode Register
000800 <sub>H</sub> to 000CFC <sub>H</sub>	Reserved				Reserved
000D00 <sub>H</sub> to 000D08 <sub>H</sub>	Reserved				R-bus Port Data Direct Read Register
000D0C <sub>H</sub>	Reserved		PDRD14 [R] ---- XXXX	PDRD15 [R] ---- XXXX	
000D10 <sub>H</sub>	Reserved	PDRD17 [R] XXXXXXXX	Reserved		
000D14 <sub>H</sub>	PDRD20 [R] - XXX- XXX	PDRD21 [R] - XXX- XXX	PDRD22 [R] ---- XXXX	Reserved	
000D18 <sub>H</sub>	PDRD24 [R] XXXXXXXX	Reserved			
000D1C <sub>H</sub>	Reserved	PDRD29 [R] XXXXXXXX	Reserved		
000D20 <sub>H</sub>	Reserved				

(Continued)

# MB91460N Series

Address	Register				Block
	+0	+1	+2	+3	
000D24H to 000D3CH	Reserved				Reserved
000D40H to 000D48H	Reserved				R-bus Port Direction Register
000D4CH	Reserved		DDR14 [R/W] ---- 0000	DDR15 [R/W] ---- 0000	
000D50H	Reserved	DDR17 [R/W] 00000000	Reserved		
000D54H	DDR20 [R/W] -000- 000	DDR21 [R/W] -000- 000	DDR22 [R/W] ---- 0000	Reserved	
000D58H	DDR24 [R/W] 00000000	Reserved			
000D5CH	Reserved	DDR29 [R/W] 00000000	Reserved		
000D60H	Reserved				
000D64H to 000D7CH	Reserved				Reserved
000D80H to 000D88H	Reserved				R-bus Port Function Register
000D8CH	Reserved		PFR14 [R/W] ---- 0000	PFR15 [R/W] ---- 0000	
000D90H	Reserved	PFR17 [R/W] 00000000	Reserved		
000D94H	PFR20 [R/W] -000- 000	PFR21 [R/W] -000- 000	PFR22 [R/W] ---- 0000	Reserved	
000D98H	PFR24 [R/W] 00000000	Reserved			
000D9CH	Reserved	PFR29 [R/W] 00000000	Reserved		
000DA0H	Reserved				
000DA4H to 000DBC_H	Reserved				Reserved
000DC0H to 000DC8H	Reserved				R-bus Extension Port Function Register
000DCC_H	Reserved		EPFR14 [R/W] ---- 0000	EPFR15 [R/W] ---- 0000	

(Continued)

# MB91460N Series

Address	Register				Block
	+0	+1	+2	+3	
000DD0H	Reserved				R-bus Extension Port Function Register
000DD4H	EPFR20 [R/W] - 000- 000	EPFR21 [R/W] - 0- - - 0- -	Reserved		
000DD8H	Reserved				
000DDCH	Reserved				
000DE0H	Reserved				
000DE4H to 000DFCH	Reserved				Reserved
000E00H to 000E08H	Reserved				R-bus Port Output Drive Select Register
000E0CH	Reserved		PODR14 [R/W] - - - - 0000	PODR15 [R/W] - - - - 0000	
000E10H	Reserved	PODR17 [R/W] 00000000	Reserved		
000E14H	PODR20 [R/W] - 000- 000	PODR21 [R/W] - 000- 000	PODR22 [R/W] - - - - 0000	Reserved	
000E18H	PODR24 [R/W] 00000000	Reserved			
000E1CH	Reserved	PODR29 [R/W] 00000000	Reserved		
000E20H	Reserved				
000E24H to 000E3CH	Reserved				Reserved
000E40H to 000E48H	Reserved				R-bus Pin Input Level Select Register
000E4CH	Reserved		PILR14 [R/W] - - - - 0000	PILR15 [R/W] - - - - 0000	
000E50H	Reserved	PILR17 [R/W] 00000000	Reserved		
000E54H	PILR20 [R/W] - 000- 000	PILR21 [R/W] - 000- 000	PILR22 [R/W] - - - - 0000	Reserved	
000E58H	PILR24 [R/W] 00000000	Reserved			
000E5CH	Reserved	PILR29 [R/W] 00000000	Reserved		
000E60H	Reserved				

(Continued)

# MB91460N Series

Address	Register				Block
	+0	+1	+2	+3	
000E64H to 000E7CH	Reserved				Reserved
000E80H to 000E88H	Reserved				R-bus Port Extra Input Level Select Register
000E8CH	Reserved		EPILR14 [R/W] ---- 0000	EPILR15 [R/W] ---- 0000	
000E90H	Reserved	EPILR17 [R/W] 00000000	Reserved		
000E94H	EPILR20 [R/W] - 000- 000	EPILR21 [R/W] - 000- 000	EPILR22 [R/W] ---- 0000	Reserved	
000E98H	EPILR24 [R/W] 00000000	Reserved			
000E9CH, 000EA0H	Reserved				
000EA4H to 000EBCCH	Reserved				
000EC0H to 000EC8H	Reserved				R-bus Port Pull-up/down Enable Register
000ECCCH	Reserved		PPER14 [R/W] ---- 0000	PPER15 [R/W] ---- 0000	
000ED0H	Reserved	PPER17 [R/W] 00000000	Reserved		
000ED4H	PPER20 [R/W] -000- 000	PPER21 [R/W] -000- 000	PPER22 [R/W] ---- 0000	Reserved	
000ED8H	PPER24 [R/W] 00000000	Reserved			
000EDCH	Reserved	PPER29 [R/W] 00000000	Reserved		
000EE0H	Reserved				
000EE4H to 000EFCCH	Reserved				Reserved
000F00H to 000F08H	Reserved				R-bus Port Pull-up/down Control Register

(Continued)

# MB91460N Series

Address	Register				Block
	+0	+1	+2	+3	
000F0CH	Reserved		PPCR14 [R/W] ---- 1111	PPCR15 [R/W] ---- 1111	R-bus Port Pull-up/down Control Register
000F10H	Reserved	PPCR17 [R/W] 11111111	Reserved		
000F14H	PPCR20 [R/W] -111-111	PPCR21 [R/W] -111-111	PPCR22 [R/W] ---- 1111	Reserved	
000F18H	PPCR24 [R/W] 11111111	Reserved			
000F1CH	Reserved	PPCR29 [R/W] 11111111	Reserved		
000F20H	Reserved				
000F24H to 000F3CH	Reserved				Reserved
001000H	DMASA0 [R/W] XXXXXXXX XXXXXXXX XXXXXXXX XXXXXXXX				DMAC
001004H	DMADA0 [R/W] XXXXXXXX XXXXXXXX XXXXXXXX XXXXXXXX				
001008H	DMASA1 [R/W] XXXXXXXX XXXXXXXX XXXXXXXX XXXXXXXX				
00100CH	DMADA1 [R/W] XXXXXXXX XXXXXXXX XXXXXXXX XXXXXXXX				
001010H	DMASA2 [R/W] XXXXXXXX XXXXXXXX XXXXXXXX XXXXXXXX				
001014H	DMADA2 [R/W] XXXXXXXX XXXXXXXX XXXXXXXX XXXXXXXX				
001018H	DMASA3 [R/W] XXXXXXXX XXXXXXXX XXXXXXXX XXXXXXXX				
00101CH	DMADA3 [R/W] XXXXXXXX XXXXXXXX XXXXXXXX XXXXXXXX				
001020H	DMASA4 [R/W] XXXXXXXX XXXXXXXX XXXXXXXX XXXXXXXX				
001024H	DMADA4 [R/W] XXXXXXXX XXXXXXXX XXXXXXXX XXXXXXXX				
001028H to 006FFCH	Reserved				Reserved

(Continued)

# MB91460N Series

Address	Register				Block
	+0	+1	+2	+3	
007000 <sub>H</sub>	FMCS [R/W] 01101000	FMCR [R/W] ----0000	FCHCR [R/W] -----00 10000011		Flash Memory/ I-Cache Control Register
007004 <sub>H</sub>	FMWT [R/W] 11111111 01011101		FMWT2 [R/W] - 101 -----	FMPS [R/W] ----- 000	
007008 <sub>H</sub>	FMAC [R] ----- 00000 00000000 00000000				
00700C <sub>H</sub>	FCHA0 [R/W] ----- -0000000 00000000 00000000				
007010 <sub>H</sub>	FCHA1 [R/W] ----- -0000000 00000000 00000000				I-Cache Non-cacheable area setting Register
007014 <sub>H</sub> to 00AFFC <sub>H</sub>	Reserved				Reserved
00B000 <sub>H</sub> to 00BFFC <sub>H</sub>	MB91F463NA BI-ROM size is 4 Kbytes : 00B000 <sub>H</sub> to 00BFFF <sub>H</sub>				BI-ROM 4 Kbytes
00C000 <sub>H</sub> to 00C3FC <sub>H</sub>	Reserved				Reserved
00C400 <sub>H</sub>	CTRLR4 [R/W] 00000000 00000001		STATR4 [R/W] 00000000 00000000		CAN 4 Control Register
00C404 <sub>H</sub>	ERRCNT4 [R] 00000000 00000000		BTR4 [R/W] 00100011 00000001		
00C408 <sub>H</sub>	INTR4 [R] 00000000 00000000		TESTR4 [R/W] 00000000 X0000000		
00C40C <sub>H</sub>	BRPE4 [R/W] 00000000 00000000		Reserved		
00C410 <sub>H</sub>	IF1CREQ4 [R/W] 00000000 00000001		IF1CMSK4 [R/W] 00000000 00000000		CAN 4 IF1 Register
00C414 <sub>H</sub>	IF1MSK24 [R/W] 11111111 11111111		IF1MSK14 [R/W] 11111111 11111111		
00C418 <sub>H</sub>	IF1ARB24 [R/W] 00000000 00000000		IF1ARB14 [R/W] 00000000 00000000		
00C41C <sub>H</sub>	IF1MCTR4 [R/W] 00000000 00000000		Reserved		
00C420 <sub>H</sub>	IF1DTA14 [R/W] 00000000 00000000		IF1DTA24 [R/W] 00000000 00000000		
00C424 <sub>H</sub>	IF1DTB14 [R/W] 00000000 00000000		IF1DTB24 [R/W] 00000000 00000000		
00C428 <sub>H</sub> , 00C42C <sub>H</sub>	Reserved				

(Continued)

# MB91460N Series

Address	Register				Block
	+0	+1	+2	+3	
00C430 <sub>H</sub>	IF1DTA24 [R/W] 00000000 00000000		IF1DTA14 [R/W] 00000000 00000000		CAN 4 IF1 Register
00C434 <sub>H</sub>	IF1DTB24 [R/W] 00000000 00000000		IF1DTB14 [R/W] 00000000 00000000		
00C438 <sub>H</sub> , 00C43C <sub>H</sub>	Reserved				
00C440 <sub>H</sub>	IF2CREQ4 [R/W] 00000000 00000001		IF2CMSK4 [R/W] 00000000 00000000		CAN 4 IF2 Register
00C444 <sub>H</sub>	IF2MSK24 [R/W] 11111111 11111111		IF2MSK14 [R/W] 11111111 11111111		
00C448 <sub>H</sub>	IF2ARB24 [R/W] 00000000 00000000		IF2ARB14 [R/W] 00000000 00000000		
00C44C <sub>H</sub>	IF2MCTR4 [R/W] 00000000 00000000		Reserved		
00C450 <sub>H</sub>	IF2DTA14 [R/W] 00000000 00000000		IF2DTA24 [R/W] 00000000 00000000		
00C454 <sub>H</sub>	IF2DTB14 [R/W] 00000000 00000000		IF2DTB24 [R/W] 00000000 00000000		
00C458 <sub>H</sub> , 00C45C <sub>H</sub>	Reserved				
00C460 <sub>H</sub>	IF2DTA24 [R/W] 00000000 00000000		IF2DTA14 [R/W] 00000000 00000000		
00C464 <sub>H</sub>	IF2DTB24 [R/W] 00000000 00000000		IF2DTB14 [R/W] 00000000 00000000		
00C468 <sub>H</sub> to 00C47C <sub>H</sub>	Reserved				
00C480 <sub>H</sub>	TREQR24 [R] 00000000 00000000		TREQR14 [R] 00000000 00000000		CAN 4 Status Flags
00C484 <sub>H</sub>	TREQR44 [R] 00000000 00000000		TREQR34 [R] 00000000 00000000		
00C488 <sub>H</sub>	TREQR64 [R] 00000000 00000000		TREQR54 [R] 00000000 00000000		
00C48C <sub>H</sub>	TREQR84 [R] 00000000 00000000		TREQR74 [R] 00000000 00000000		
00C490 <sub>H</sub>	NEWDT24 [R] 00000000 00000000		NEWDT14 [R] 00000000 00000000		
00C494 <sub>H</sub>	NEWDT44 [R] 00000000 00000000		NEWDT34 [R] 00000000 00000000		

(Continued)

# MB91460N Series

Address	Register				Block
	+0	+1	+2	+3	
00C498 <sub>H</sub>	NEWDT64 [R] 00000000 00000000		NEWDT54 [R] 00000000 00000000		CAN 4 Status Flags
00C49C <sub>H</sub>	NEWDT84 [R] 00000000 00000000		NEWDT74 [R] 00000000 00000000		
00C4A0 <sub>H</sub>	INTPND24 [R] 00000000 00000000		INTPND14 [R] 00000000 00000000		
00C4A4 <sub>H</sub>	INTPND44 [R] 00000000 00000000		INTPND34 [R] 00000000 00000000		
00C4A8 <sub>H</sub>	INTPND64 [R] 00000000 00000000		INTPND54 [R] 00000000 00000000		
00C4AC <sub>H</sub>	INTPND84 [R] 00000000 00000000		INTPND74 [R] 00000000 00000000		
00C4B0 <sub>H</sub>	MSGVAL24 [R] 00000000 00000000		MSGVAL14 [R] 00000000 00000000		
00C4B4 <sub>H</sub>	MSGVAL44 [R] 00000000 00000000		MSGVAL34 [R] 00000000 00000000		
00C4B8 <sub>H</sub>	MSGVAL64 [R] 00000000 00000000		MSGVAL54 [R] 00000000 00000000		
00C4BC <sub>H</sub>	MSGVAL84 [R] 00000000 00000000		MSGVAL74 [R] 00000000 00000000		
00C4C0 <sub>H</sub> to 00C4FC <sub>H</sub>	Reserved				
00C500 <sub>H</sub>	CTRLR5 [R/W] 00000000 00000001		STATR5 [R/W] 00000000 00000000		CAN 5 Control Register
00C504 <sub>H</sub>	ERRCNT5 [R] 00000000 00000000		BTR5 [R/W] 00100011 00000001		
00C508 <sub>H</sub>	INTR5 [R] 00000000 00000000		TESTR5 [R/W] 00000000 X0000000		
00C50C <sub>H</sub>	BRPE5 [R/W] 00000000 00000000		Reserved		
00C510 <sub>H</sub>	IF1CREQ5 [R/W] 00000000 00000001		IF1CMSK5 [R/W] 00000000 00000000		CAN 5 IF1 Register
00C514 <sub>H</sub>	IF1MSK25 [R/W] 11111111 11111111		IF1MSK15 [R/W] 11111111 11111111		
00C518 <sub>H</sub>	IF1ARB25 [R/W] 00000000 00000000		IF1ARB15 [R/W] 00000000 00000000		
00C51C <sub>H</sub>	IF1MCTR5 [R/W] 00000000 00000000		Reserved		
00C520 <sub>H</sub>	IF1DTA15 [R/W] 00000000 00000000		IF1DTA25 [R/W] 00000000 00000000		

(Continued)

# MB91460N Series

Address	Register				Block
	+0	+1	+2	+3	
00C524H	IF1DTB15 [R/W] 00000000 00000000		IF1DTB25 [R/W] 00000000 00000000		CAN 5 IF1 Register
00C528H, 00C52CH	Reserved				
00C530H	IF1DTA25 [R/W] 00000000 00000000		IF1DTA15 [R/W] 00000000 00000000		
00C534H	IF1DTB25 [R/W] 00000000 00000000		IF1DTB15 [R/W] 00000000 00000000		
00C538H, 00C53CH	Reserved				
00C540H	IF2CREQ5 [R/W] 00000000 00000001		IF2CMSK5 [R/W] 00000000 00000000		CAN 5 IF2 Register
00C544H	IF2MSK25 [R/W] 11111111 11111111		IF2MSK15 [R/W] 11111111 11111111		
00C548H	IF2ARB25 [R/W] 00000000 00000000		IF2ARB15 [R/W] 00000000 00000000		
00C54CH	IF2MCTR5 [R/W] 00000000 00000000		Reserved		
00C550H	IF2DTA15 [R/W] 00000000 00000000		IF2DTA25 [R/W] 00000000 00000000		
00C554H	IF2DTB15 [R/W] 00000000 00000000		IF2DTB25 [R/W] 00000000 00000000		
00C558H, 00C55CH	Reserved				
00C560H	IF2DTA25 [R/W] 00000000 00000000		IF2DTA15 [R/W] 00000000 00000000		
00C564H	IF2DTB25 [R/W] 00000000 00000000		IF2DTB15 [R/W] 00000000 00000000		
00C568H to 00C57CH	Reserved				
00C580H	TREQR25 [R] 00000000 00000000		TREQR15 [R] 00000000 00000000		CAN 5 Status Flags
00C584H	TREQR45 [R] 00000000 00000000		TREQR35 [R] 00000000 00000000		
00C588H	TREQR65 [R] 00000000 00000000		TREQR55 [R] 00000000 00000000		

(Continued)

# MB91460N Series

Address	Register				Block
	+0	+1	+2	+3	
00C58CH	TREQR85 [R] 00000000 00000000		TREQR75 [R] 00000000 00000000		CAN 5 Status Flags
00C590H	NEWDT25 [R] 00000000 00000000		NEWDT15 [R] 00000000 00000000		
00C594H	NEWDT45 [R] 00000000 00000000		NEWDT35 [R] 00000000 00000000		
00C598H	NEWDT65 [R] 00000000 00000000		NEWDT55 [R] 00000000 00000000		
00C59CH	NEWDT85 [R] 00000000 00000000		NEWDT75 [R] 00000000 00000000		
00C5A0H	INTPND25 [R] 00000000 00000000		INTPND15 [R] 00000000 00000000		
00C5A4H	INTPND45 [R] 00000000 00000000		INTPND35 [R] 00000000 00000000		
00C5A8H	INTPND65 [R] 00000000 00000000		INTPND55 [R] 00000000 00000000		
00C5ACH	INTPND85 [R] 00000000 00000000		INTPND75 [R] 00000000 00000000		
00C5B0H	MSGVAL25 [R] 00000000 00000000		MSGVAL15 [R] 00000000 00000000		
00C5B4H	MSGVAL45 [R] 00000000 00000000		MSGVAL35 [R] 00000000 00000000		
00C5B8H	MSGVAL65 [R] 00000000 00000000		MSGVAL55 [R] 00000000 00000000		
00C5BCH	MSGVAL85 [R] 00000000 00000000		MSGVAL75 [R] 00000000 00000000		
00C5C0H to 00EFCCH	Reserved				
00F000H	BCTRL [R/W] ----- 11111100 00000000				EDSU / MPU
00F004H	BSTAT [R/W] ----- 000 00000000 10 -- 0000				
00F008H	BIAC [R] 00000000 00000000 00000000 00000000				
00F00CH	BOAC [R] 00000000 00000000 00000000 00000000				
00F010H	BIRQ [R/W] 00000000 00000000 00000000 00000000				

(Continued)

# MB91460N Series

Address	Register				Block
	+0	+1	+2	+3	
00F014H to 00F01CH	Reserved				EDSU / MPU
00F020H	BCR0 [R/W] ----- 00000000 00000000 00000000				
00F024H	BCR1 [R/W] ----- 00000000 00000000 00000000				
00F028H	BCR2 [R/W] ----- 00000000 00000000 00000000				
00F02CH	BCR3 [R/W] ----- 00000000 00000000 00000000				
00F030H to 00F03CH	Reserved				
00F040H to 00F07CH	Reserved				Reserved
00F080H	BAD0 [R/W] XXXXXXXX XXXXXXXX XXXXXXXX XXXXXXXX				EDSU / MPU
00F084H	BAD1 [R/W] XXXXXXXX XXXXXXXX XXXXXXXX XXXXXXXX				
00F088H	BAD2 [R/W] XXXXXXXX XXXXXXXX XXXXXXXX XXXXXXXX				
00F08CH	BAD3 [R/W] XXXXXXXX XXXXXXXX XXXXXXXX XXXXXXXX				
00F090H	BAD4 [R/W] XXXXXXXX XXXXXXXX XXXXXXXX XXXXXXXX				
00F094H	BAD5 [R/W] XXXXXXXX XXXXXXXX XXXXXXXX XXXXXXXX				
00F098H	BAD6 [R/W] XXXXXXXX XXXXXXXX XXXXXXXX XXXXXXXX				
00F09CH	BAD7 [R/W] XXXXXXXX XXXXXXXX XXXXXXXX XXXXXXXX				
00F0A0H	BAD8 [R/W] XXXXXXXX XXXXXXXX XXXXXXXX XXXXXXXX				

(Continued)

# MB91460N Series

Address	Register				Block
	+0	+1	+2	+3	
00F0A4 <sub>H</sub>	BAD9 [R/W] XXXXXXXX XXXXXXXX XXXXXXXX XXXXXXXX				EDSU / MPU
00F0A8 <sub>H</sub>	BAD10 [R/W] XXXXXXXX XXXXXXXX XXXXXXXX XXXXXXXX				
00F0AC <sub>H</sub>	BAD11 [R/W] XXXXXXXX XXXXXXXX XXXXXXXX XXXXXXXX				
00F0B0 <sub>H</sub>	BAD12 [R/W] XXXXXXXX XXXXXXXX XXXXXXXX XXXXXXXX				
00F0B4 <sub>H</sub>	BAD13 [R/W] XXXXXXXX XXXXXXXX XXXXXXXX XXXXXXXX				
00F0B8 <sub>H</sub>	BAD14 [R/W] XXXXXXXX XXXXXXXX XXXXXXXX XXXXXXXX				
00F0BC <sub>H</sub>	BAD15 [R/W] XXXXXXXX XXXXXXXX XXXXXXXX XXXXXXXX				
00F0C0 <sub>H</sub> to 00F0FC <sub>H</sub>	Reserved				
00F100 <sub>H</sub> to 02DFFC <sub>H</sub>	Reserved				Reserved
02E000 <sub>H</sub> to 02FFFC <sub>H</sub>	MB91F463NA Data RAM size is 8 Kbytes: 02E000 <sub>H</sub> to 02FFFF <sub>H</sub> (data access is 0 wait cycle)				D-RAM 8 Kbytes
030000 <sub>H</sub> to 0307FC <sub>H</sub>	MB91F463NA Instruction/data RAM size is 2 Kbytes: 030000 <sub>H</sub> to 0307FF <sub>H</sub> (instruction access is 0 wait cycle, data access is 1 wait cycle)				I/D-RAM 2 Kbytes
030800 <sub>H</sub> to 0BFFFC <sub>H</sub>	Reserved				Reserved
0C0000 <sub>H</sub> to 0DFFFC <sub>H</sub>	ROMS04 area (128 Kbytes)				Flash memory 256 Kbytes
0E0000 <sub>H</sub> to 0FFFF4 <sub>H</sub>	ROMS05 area (128 Kbytes)				
0FFFF8 <sub>H</sub>	FMV [R] XXXXXXXX <sub>H</sub>				Reset/Mode Vector
0FFFFC <sub>H</sub>	FRV [R] XXXXXXXX <sub>H</sub>				
100000 <sub>H</sub> to 147FFC <sub>H</sub>	Reserved				Reserved

(Continued)

(Continued)

Address	Register				Block
	+0	+1	+2	+3	
148000 <sub>H</sub> to 14FFFC <sub>H</sub>	ROMS07 area (32 Kbytes)				Flash memory 32 Kbytes
148000 <sub>H</sub> to 4FFFC <sub>H</sub>	Reserved				Reserved

\* : The lower 16 bits (DTC15 to DTC0) of DMACA0 to DMACA4 cannot be accessed in bytes.

# MB91460N Series

## ■ INTERRUPT SOURCE TABLE

Interrupt source	Interrupt number		Interrupt level		Interrupt vector		Resource number*1
	Decimal	Hexa-decimal	Setting register	Register address	Offset	Default vector address	
Reset	0	00	—	—	3FC <sub>H</sub>	000FFFFC <sub>H</sub>	—
Mode vector	1	01	—	—	3F8 <sub>H</sub>	000FFFF8 <sub>H</sub>	—
System reserved	2	02	—	—	3F4 <sub>H</sub>	000FFFF4 <sub>H</sub>	—
System reserved	3	03	—	—	3F0 <sub>H</sub>	000FFFF0 <sub>H</sub>	—
System reserved	4	04	—	—	3EC <sub>H</sub>	000FFFE <sub>C</sub>	—
CPU supervisor mode (INT #5 instruction) *2	5	05	—	—	3E8 <sub>H</sub>	000FFFE8 <sub>H</sub>	—
Memory protection exception *2	6	06	—	—	3E4 <sub>H</sub>	000FFFE4 <sub>H</sub>	—
System reserved	7	07	—	—	3E0 <sub>H</sub>	000FFFE0 <sub>H</sub>	—
System reserved	8	08	—	—	3DC <sub>H</sub>	000FFFD <sub>C</sub>	—
System reserved	9	09	—	—	3D8 <sub>H</sub>	000FFFD8 <sub>H</sub>	—
System reserved	10	0A	—	—	3D4 <sub>H</sub>	000FFFD4 <sub>H</sub>	—
System reserved	11	0B	—	—	3D0 <sub>H</sub>	000FFFD0 <sub>H</sub>	—
System reserved	12	0C	—	—	3CC <sub>H</sub>	000FFFC <sub>C</sub>	—
System reserved	13	0D	—	—	3C8 <sub>H</sub>	000FFFC8 <sub>H</sub>	—
Undefined instruction exception	14	0E	—	—	3C4 <sub>H</sub>	000FFFC4 <sub>H</sub>	—
NMI request	15	0F	F <sub>H</sub> fixed		3C0 <sub>H</sub>	000FFFC0 <sub>H</sub>	—
External interrupt 0	16	10	ICR00	440 <sub>H</sub>	3BC <sub>H</sub>	000FFFB <sub>C</sub>	0, 16
External interrupt 1	17	11			3B8 <sub>H</sub>	000FFFB8 <sub>H</sub>	1, 17
External interrupt 2	18	12	ICR01	441 <sub>H</sub>	3B4 <sub>H</sub>	000FFFB4 <sub>H</sub>	2, 18
External interrupt 3	19	13			3B0 <sub>H</sub>	000FFFB0 <sub>H</sub>	3, 19
External interrupt 4	20	14	ICR02	442 <sub>H</sub>	3AC <sub>H</sub>	000FFFA <sub>C</sub>	20
External interrupt 5	21	15			3A8 <sub>H</sub>	000FFFA8 <sub>H</sub>	21
External interrupt 6	22	16	ICR03	443 <sub>H</sub>	3A4 <sub>H</sub>	000FFFA4 <sub>H</sub>	22
External interrupt 7	23	17			3A0 <sub>H</sub>	000FFFA0 <sub>H</sub>	23
System reserved	24	18	ICR04	444 <sub>H</sub>	39C <sub>H</sub>	000FFF9 <sub>C</sub>	—
System reserved	25	19			398 <sub>H</sub>	000FFF98 <sub>H</sub>	—
System reserved	26	1A	ICR05	445 <sub>H</sub>	394 <sub>H</sub>	000FFF94 <sub>H</sub>	—
System reserved	27	1B			390 <sub>H</sub>	000FFF90 <sub>H</sub>	—
External interrupt 12	28	1C	ICR06	446 <sub>H</sub>	38C <sub>H</sub>	000FFF8 <sub>C</sub>	—
External interrupt 13	29	1D			388 <sub>H</sub>	000FFF88 <sub>H</sub>	—
System reserved	30	1E	ICR07	447 <sub>H</sub>	384 <sub>H</sub>	000FFF84 <sub>H</sub>	—
System reserved	31	1F			380 <sub>H</sub>	000FFF80 <sub>H</sub>	—

(Continued)

Interrupt source	Interrupt number		Interrupt level		Interrupt vector		Resource number*1
	Decimal	Hexadecimal	Setting register	Register address	Offset	Default vector address	
Reload timer 0	32	20	ICR08	448 <sub>H</sub>	37C <sub>H</sub>	000FFF7C <sub>H</sub>	4, 32
Reload timer 1	33	21			378 <sub>H</sub>	000FFF78 <sub>H</sub>	5, 33
Reload timer 2	34	22	ICR09	449 <sub>H</sub>	374 <sub>H</sub>	000FFF74 <sub>H</sub>	34
Reload timer 3	35	23			370 <sub>H</sub>	000FFF70 <sub>H</sub>	35
System reserved	36	24	ICR10	44A <sub>H</sub>	36C <sub>H</sub>	000FFF6C <sub>H</sub>	36
System reserved	37	25			368 <sub>H</sub>	000FFF68 <sub>H</sub>	37
System reserved	38	26	ICR11	44B <sub>H</sub>	364 <sub>H</sub>	000FFF64 <sub>H</sub>	38
Reload timer 7	39	27			360 <sub>H</sub>	000FFF60 <sub>H</sub>	39
Free-run timer 0	40	28	ICR12	44C <sub>H</sub>	35C <sub>H</sub>	000FFF5C <sub>H</sub>	40
Free-run timer 1	41	29			358 <sub>H</sub>	000FFF58 <sub>H</sub>	41
Free-run timer 2	42	2A	ICR13	44D <sub>H</sub>	354 <sub>H</sub>	000FFF54 <sub>H</sub>	42
Free-run timer 3	43	2B			350 <sub>H</sub>	000FFF50 <sub>H</sub>	43
System reserved	44	2C	ICR14	44E <sub>H</sub>	34C <sub>H</sub>	000FFF4C <sub>H</sub>	44
System reserved	45	2D			348 <sub>H</sub>	000FFF48 <sub>H</sub>	45
System reserved	46	2E	ICR15	44F <sub>H</sub>	344 <sub>H</sub>	000FFF44 <sub>H</sub>	46
System reserved	47	2F			340 <sub>H</sub>	000FFF40 <sub>H</sub>	47
System reserved	48	30	ICR16	450 <sub>H</sub>	33C <sub>H</sub>	000FFF3C <sub>H</sub>	—
System reserved	49	31			338 <sub>H</sub>	000FFF38 <sub>H</sub>	—
System reserved	50	32	ICR17	451 <sub>H</sub>	334 <sub>H</sub>	000FFF34 <sub>H</sub>	—
System reserved	51	33			330 <sub>H</sub>	000FFF30 <sub>H</sub>	—
CAN 4	52	34	ICR18	452 <sub>H</sub>	32C <sub>H</sub>	000FFF2C <sub>H</sub>	—
CAN 5	53	35			328 <sub>H</sub>	000FFF28 <sub>H</sub>	—
LIN-USART0 RX	54	36	ICR19	453 <sub>H</sub>	324 <sub>H</sub>	000FFF24 <sub>H</sub>	6, 48
LIN-USART0 TX	55	37			320 <sub>H</sub>	000FFF20 <sub>H</sub>	7, 49
LIN-USART1 RX	56	38	ICR20	454 <sub>H</sub>	31C <sub>H</sub>	000FFF1C <sub>H</sub>	8, 50
LIN-USART1 TX	57	39			318 <sub>H</sub>	000FFF18 <sub>H</sub>	9, 51
LIN-USART2 RX	58	3A	ICR21	455 <sub>H</sub>	314 <sub>H</sub>	000FFF14 <sub>H</sub>	52
LIN-USART2 TX	59	3B			310 <sub>H</sub>	000FFF10 <sub>H</sub>	53
LIN-USART3 RX	60	3C	ICR22	456 <sub>H</sub>	30C <sub>H</sub>	000FFF0C <sub>H</sub>	54
LIN-USART3 TX	61	3D			308 <sub>H</sub>	000FFF08 <sub>H</sub>	55
System reserved	62	3E	ICR23 *3	457 <sub>H</sub>	304 <sub>H</sub>	000FFF04 <sub>H</sub>	—
Delayed interrupt	63	3F			300 <sub>H</sub>	000FFF00 <sub>H</sub>	—

(Continued)

# MB91460N Series

Interrupt source	Interrupt number		Interrupt level		Interrupt vector		Resource number*1
	Decimal	Hexa-decimal	Setting register	Register address	Offset	Default vector address	
System reserved *4	64	40	(ICR24)	(458H)	2FC <sub>H</sub>	000FFEFC <sub>H</sub>	—
System reserved *4	65	41			2F8 <sub>H</sub>	000FFEF8 <sub>H</sub>	—
System reserved	66	42	ICR25	459 <sub>H</sub>	2F4 <sub>H</sub>	000FFEFC <sub>H</sub>	10, 56
System reserved	67	43			2F0 <sub>H</sub>	000FFEF0 <sub>H</sub>	11, 57
System reserved	68	44	ICR26	45A <sub>H</sub>	2EC <sub>H</sub>	000FFEEC <sub>H</sub>	12, 58
System reserved	69	45			2E8 <sub>H</sub>	000FFEE8 <sub>H</sub>	13, 59
System reserved	70	46	ICR27	45B <sub>H</sub>	2E4 <sub>H</sub>	000FFEE4 <sub>H</sub>	60
System reserved	71	47			2E0 <sub>H</sub>	000FFEE0 <sub>H</sub>	61
System reserved	72	48	ICR28	45C <sub>H</sub>	2DC <sub>H</sub>	000FFEDC <sub>H</sub>	62
System reserved	73	49			2D8 <sub>H</sub>	000FFED8 <sub>H</sub>	63
I <sup>2</sup> C 2	74	4A	ICR29	45D <sub>H</sub>	2D4 <sub>H</sub>	000FFED4 <sub>H</sub>	—
I <sup>2</sup> C 3	75	4B			2D0 <sub>H</sub>	000FFED0 <sub>H</sub>	—
System reserved	76	4C	ICR30	45E <sub>H</sub>	2CC <sub>H</sub>	000FFEC <sub>H</sub>	64
System reserved	77	4D			2C8 <sub>H</sub>	000FFEC8 <sub>H</sub>	65
System reserved	78	4E	ICR31	45F <sub>H</sub>	2C4 <sub>H</sub>	000FFEC4 <sub>H</sub>	66
System reserved	79	4F			2C0 <sub>H</sub>	000FFEC0 <sub>H</sub>	67
System reserved	80	50	ICR32	460 <sub>H</sub>	2BC <sub>H</sub>	000FFEB <sub>H</sub>	68
System reserved	81	51			2B8 <sub>H</sub>	000FFEB8 <sub>H</sub>	69
System reserved	82	52	ICR33	461 <sub>H</sub>	2B4 <sub>H</sub>	000FFEB4 <sub>H</sub>	70
System reserved	83	53			2B0 <sub>H</sub>	000FFEB0 <sub>H</sub>	71
System reserved	84	54	ICR34	462 <sub>H</sub>	2AC <sub>H</sub>	000FFEAC <sub>H</sub>	72
System reserved	85	55			2A8 <sub>H</sub>	000FFEA8 <sub>H</sub>	73
System reserved	86	56	ICR35	463 <sub>H</sub>	2A4 <sub>H</sub>	000FFEA4 <sub>H</sub>	74
System reserved	87	57			2A0 <sub>H</sub>	000FFEA0 <sub>H</sub>	75
System reserved	88	58	ICR36	464 <sub>H</sub>	29C <sub>H</sub>	000FFE9C <sub>H</sub>	76
System reserved	89	59			298 <sub>H</sub>	000FFE98 <sub>H</sub>	77
System reserved	90	5A	ICR37	465 <sub>H</sub>	294 <sub>H</sub>	000FFE94 <sub>H</sub>	78
System reserved	91	5B			290 <sub>H</sub>	000FFE90 <sub>H</sub>	79
Input capture 0	92	5C	ICR38	466 <sub>H</sub>	28C <sub>H</sub>	000FFE8C <sub>H</sub>	80
Input capture 1	93	5D			288 <sub>H</sub>	000FFE88 <sub>H</sub>	81
Input capture 2	94	5E	ICR39	467 <sub>H</sub>	284 <sub>H</sub>	000FFE84 <sub>H</sub>	82
Input capture 3	95	5F			280 <sub>H</sub>	000FFE80 <sub>H</sub>	83

(Continued)

# MB91460N Series

Interrupt source	Interrupt number		Interrupt level		Interrupt vector		Resource number*1
	Decimal	Hexa-decimal	Setting register	Register address	Offset	Default vector address	
System reserved	96	60	ICR40	468 <sub>H</sub>	27C <sub>H</sub>	000FFE7C <sub>H</sub>	84
System reserved	97	61			278 <sub>H</sub>	000FFE78 <sub>H</sub>	85
System reserved	98	62	ICR41	469 <sub>H</sub>	274 <sub>H</sub>	000FFE74 <sub>H</sub>	86
System reserved	99	63			270 <sub>H</sub>	000FFE70 <sub>H</sub>	87
Output compare 0	100	64	ICR42	46A <sub>H</sub>	26C <sub>H</sub>	000FFE6C <sub>H</sub>	88
Output compare 1	101	65			268 <sub>H</sub>	000FFE68 <sub>H</sub>	89
Output compare 2	102	66	ICR43	46B <sub>H</sub>	264 <sub>H</sub>	000FFE64 <sub>H</sub>	90
Output compare 3	103	67			260 <sub>H</sub>	000FFE60 <sub>H</sub>	91
System reserved	104	68	ICR44	46C <sub>H</sub>	25C <sub>H</sub>	000FFE5C <sub>H</sub>	92
System reserved	105	69			258 <sub>H</sub>	000FFE58 <sub>H</sub>	93
System reserved	106	6A	ICR45	46D <sub>H</sub>	254 <sub>H</sub>	000FFE54 <sub>H</sub>	94
System reserved	107	6B			250 <sub>H</sub>	000FFE50 <sub>H</sub>	95
System reserved	108	6C	ICR46	46E <sub>H</sub>	24C <sub>H</sub>	000FFE4C <sub>H</sub>	—
Phase Frequency modulator	109	6D			248 <sub>H</sub>	000FFE48 <sub>H</sub>	—
System reserved	110	6E	ICR47 *4	46F <sub>H</sub>	244 <sub>H</sub>	000FFE44 <sub>H</sub>	—
System reserved	111	6F			240 <sub>H</sub>	000FFE40 <sub>H</sub>	—
PPG0	112	70	ICR48	470 <sub>H</sub>	23C <sub>H</sub>	000FFE3C <sub>H</sub>	15, 96
PPG1	113	71			238 <sub>H</sub>	000FFE38 <sub>H</sub>	97
PPG2	114	72	ICR49	471 <sub>H</sub>	234 <sub>H</sub>	000FFE34 <sub>H</sub>	98
PPG3	115	73			230 <sub>H</sub>	000FFE30 <sub>H</sub>	99
PPG4	116	74	ICR50	472 <sub>H</sub>	22C <sub>H</sub>	000FFE2C <sub>H</sub>	100
PPG5	117	75			228 <sub>H</sub>	000FFE28 <sub>H</sub>	101
PPG6	118	76	ICR51	473 <sub>H</sub>	224 <sub>H</sub>	000FFE24 <sub>H</sub>	102
PPG7	119	77			220 <sub>H</sub>	000FFE20 <sub>H</sub>	103
System reserved	120	78	ICR52	474 <sub>H</sub>	21C <sub>H</sub>	000FFE1C <sub>H</sub>	104
System reserved	121	79			218 <sub>H</sub>	000FFE18 <sub>H</sub>	105
System reserved	122	7A	ICR53	475 <sub>H</sub>	214 <sub>H</sub>	000FFE14 <sub>H</sub>	106
System reserved	123	7B			210 <sub>H</sub>	000FFE10 <sub>H</sub>	107
System reserved	124	7C	ICR54	476 <sub>H</sub>	20C <sub>H</sub>	000FFE0C <sub>H</sub>	108
System reserved	125	7D			208 <sub>H</sub>	000FFE08 <sub>H</sub>	109
System reserved	126	7E	ICR55	477 <sub>H</sub>	204 <sub>H</sub>	000FFE04 <sub>H</sub>	110
System reserved	127	7F			200 <sub>H</sub>	000FFE00 <sub>H</sub>	111

(Continued)

# MB91460N Series

(Continued)

Interrupt source	Interrupt number		Interrupt level		Interrupt vector		Resource number*1
	Decimal	Hexa-decimal	Setting register	Register address	Offset	Default vector address	
Up/down counter 0	128	80	ICR56	478 <sub>H</sub>	1FC <sub>H</sub>	000FFDFC <sub>H</sub>	—
Up/down counter 1	129	81			1F8 <sub>H</sub>	000FFDF8 <sub>H</sub>	—
System reserved	130	82	ICR57	479 <sub>H</sub>	1F4 <sub>H</sub>	000FFDF4 <sub>H</sub>	—
System reserved	131	83			1F0 <sub>H</sub>	000FFDF0 <sub>H</sub>	—
Real time clock	132	84	ICR58	47A <sub>H</sub>	1EC <sub>H</sub>	000FFDEC <sub>H</sub>	—
Calibration unit	133	85			1E8 <sub>H</sub>	000FFDE8 <sub>H</sub>	—
A/D converter 0	134	86	ICR59	47B <sub>H</sub>	1E4 <sub>H</sub>	000FFDE4 <sub>H</sub>	14, 112
System reserved	135	87			1E0 <sub>H</sub>	000FFDE0 <sub>H</sub>	—
System reserved	136	88	ICR60	47C <sub>H</sub>	1DC <sub>H</sub>	000FFDDC <sub>H</sub>	—
System reserved	137	89			1D8 <sub>H</sub>	000FFDD8 <sub>H</sub>	—
Low voltage detection	138	8A	ICR61	47D <sub>H</sub>	1D4 <sub>H</sub>	000FFDD4 <sub>H</sub>	—
System reserved	139	8B			1D0 <sub>H</sub>	000FFDD0 <sub>H</sub>	—
Time-base overflow	140	8C	ICR62	47E <sub>H</sub>	1CC <sub>H</sub>	000FFDCC <sub>H</sub>	—
PLL clock gear	141	8D			1C8 <sub>H</sub>	000FFDC8 <sub>H</sub>	—
DMA controller	142	8E	ICR63	47F <sub>H</sub>	1C4 <sub>H</sub>	000FFDC4 <sub>H</sub>	—
Main OSC stability wait	143	8F			1C0 <sub>H</sub>	000FFDC0 <sub>H</sub>	—
System reserved	144	90	—	—	1BC <sub>H</sub>	000FFDBC <sub>H</sub>	—
Used by the INT instruction	145 to 255	91 to FF	—	—	1B8 <sub>H</sub> to 000 <sub>H</sub>	000FFDB8 <sub>H</sub> to 000FFC00 <sub>H</sub>	—

\*1 : The peripheral resources to which RN (Resource Number) is assigned are capable of being DMA transfer activation sources. In addition, RN respectively corresponds to an IS (Input Source) of the DMAC channel control register A (DMACA0 to DMACA4), and the IS (Input Source) can be obtained by representing RN in a binary number and adding "1" to the head of it.

\*2 : Memory Protection Unit (MPU) support

\*3 : ICR23 can be switched to ICR47 by setting REALOS compatibility bit (address 0C03<sub>H</sub> ISO[0]).

\*4 : Used by REALOS

## ■ ELECTRICAL CHARACTERISTICS

### 1. Absolute maximum rating

Parameter	Symbol	Rating		Unit	Remarks
		Min	Max		
Power supply voltage*1	$V_{CC}$	$V_{SS} - 0.5$	$V_{SS} + 6.0$	V	
Analog power supply voltage*1	$AV_{CC}$	$V_{SS} - 0.5$	$V_{SS} + 6.0$	V	*2
Analog power supply voltage*1	$AV_{RH}$	$V_{SS} - 0.5$	$V_{SS} + 6.0$	V	*2
Input voltage*1	$V_I$	$V_{SS} - 0.3$	$V_{CC} + 0.3$	V	*3
Analog pin input voltage*1	$V_{IA}$	$V_{SS} - 0.3$	$AV_{CC} + 0.3$	V	
Output voltage*1	$V_O$	$V_{SS} - 0.3$	$V_{CC} + 0.3$	V	*3
Maximum clamp current	$I_{CLAMP}$	-2.0	+2.0	mA	*4
Total maximum clamp current	$\Sigma I_{CLAMP} $	—	20	mA	*4
"L" level maximum output current	$I_{OL}$	—	10	mA	*5
"L" level average output current	$I_{OLAV}$	—	4	mA	*6
"L" level total maximum output current	$\Sigma I_{OL}$	—	100	mA	
"L" level total average output current	$\Sigma I_{OLAV}$	—	50	mA	*7
"H" level maximum output current	$I_{OH}$	—	-10	mA	*5
"H" level average output current	$I_{OHAV}$	—	-4	mA	*6
"H" level total maximum output current	$\Sigma I_{OH}$	—	-100	mA	
"H" level total average output current	$\Sigma I_{OHAV}$	—	-20	mA	*7
Power consumption	$P_D$	—	700	mW	
Operation temperature	$T_A$	-40	+105	°C	When using $V_{CC} = 3.3$ V
		-40	+85	°C	When using $V_{CC} = 5.0$ V
Storage temperature	$T_{stg}$	-55	+125	°C	

\*1 : The parameter is based on  $V_{SS} = AV_{SS} = 0.0$  V.

\*2 :  $AV_{CC}$  and  $AV_{RH}$  must not exceed  $V_{CC} + 0.3$  V, for example, at power on.  
 $AV_{CC}$  must not exceed  $V_{CC}$ .

\*3 :  $V_I$  and  $V_O$  must not exceed  $V_{CC} + 0.3$  V. However, when the maximum value of the current to the input or the current from the input is limited by using outside parts,  $I_{CLAMP}$  ratings are applied in place of  $V_I$  ratings.

(Continued)

# MB91460N Series

(Continued)

- \*4 :
  - Corresponding pins: Pin name P29\_0 to P29\_7, P24\_0 to P24\_7, P22\_0 to P22\_3, P20\_0 to P20\_2, P20\_4 to P20\_6, P15\_0 to P15\_3, P17\_0 to P17\_7, P21\_0 to P21\_2, P21\_4 to P21\_6, P14\_0 to P14\_3
  - Use within recommended operating conditions.
  - Use at DC voltage (current).
  - The + B signal is an input signal exceeding  $V_{CC}$  voltage. The + B signal should always be applied by connecting a limiting resistor between the + B signal and the microcontroller.
  - The value of the limiting resistor should be set so that the current input to the microcontroller pin does not exceed rated values at any time regardless of instantaneously or constantly when the + B signal is input.
  - Note that when the microcontroller drive current is low, such as in the low power consumption modes, the + B input potential can increase the potential at the VCC pin via a protective diode, possibly affecting other devices.
  - Note that if the + B signal is input when the microcontroller is off (not fixed at 0 V), since the power is supplied through the pin, the microcontroller may operate incompletely.
  - Note that if the + B signal is input at power-on, since the power is supplied through the pin, the power supply voltage may become the voltage at which a power-on reset does not work.
  - Do not leave + B input pins open.
  - Note that analog input/output pins can input the + B signal only at using as a port.
- \*5 : Maximum output current is defined as the value of the peak current flowing through any one of the corresponding pins.
- \*6 : Average output current is defined as the value of the average current flowing through any one of the corresponding pins for a 100 ms period.
- \*7 : Total average output current is defined as the value of the average current flowing through all of the corresponding pins for a 100 ms period.

•Sample recommended circuit :

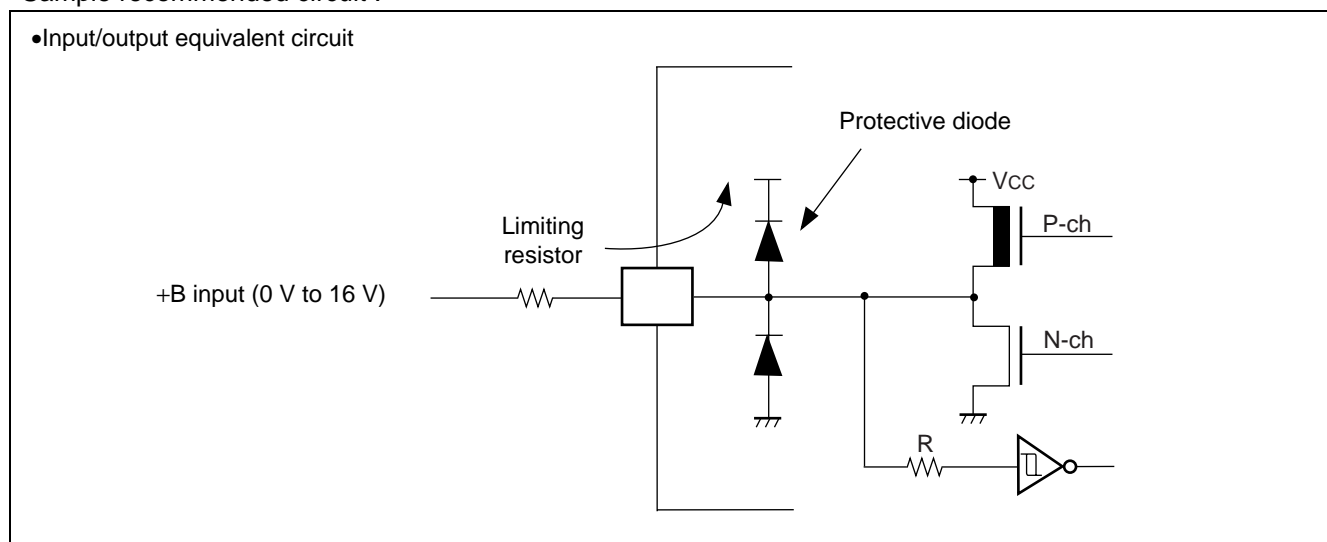

**WARNING:** Semiconductor devices can be permanently damaged by application of stress (voltage, current, temperature, etc.) in excess of absolute maximum ratings. Do not exceed these ratings.

## 2. Recommended operating conditions

( $V_{SS} = AV_{SS} = 0.0\text{ V}$ )

Parameter	Symbol	Value		Unit	Remarks
		Min	Max		
Power supply voltage	$V_{CC}$	3.0	3.6	V	When using $V_{CC} = 3.3\text{ V}$
		4.5	5.5	V	When using $V_{CC} = 5.0\text{ V}$
	$AV_{CC}$	3.0	3.6	V	When using $V_{CC} = 3.3\text{ V}$
		4.5	5.5	V	When using $V_{CC} = 5.0\text{ V}$
Smoothing capacitor	$C_S$	4.7 (accuracy within $\pm 50\%$ )		$\mu\text{F}$	Use a ceramic capacitor or a capacitor that has the similar frequency characteristics. Use a capacitor with a capacitance greater than $C_S$ as the smoothing capacitor on the VCC pin.
Operating temperature	$T_A$	-40	+105	$^{\circ}\text{C}$	When using $V_{CC} = 3.3\text{ V}$
		-40	+85	$^{\circ}\text{C}$	When using $V_{CC} = 5.0\text{ V}$

**WARNING:** The recommended operating conditions are required in order to ensure the normal operation of the semiconductor device. All of the device's electrical characteristics are warranted when the device is operated within these ranges.

Always use semiconductor devices within their recommended operating condition ranges. Operation outside these ranges may adversely affect reliability and could result in device failure.

No warranty is made with respect to uses, operating conditions, or combinations not represented on the data sheet. Users considering application outside the listed conditions are advised to contact their representatives beforehand.

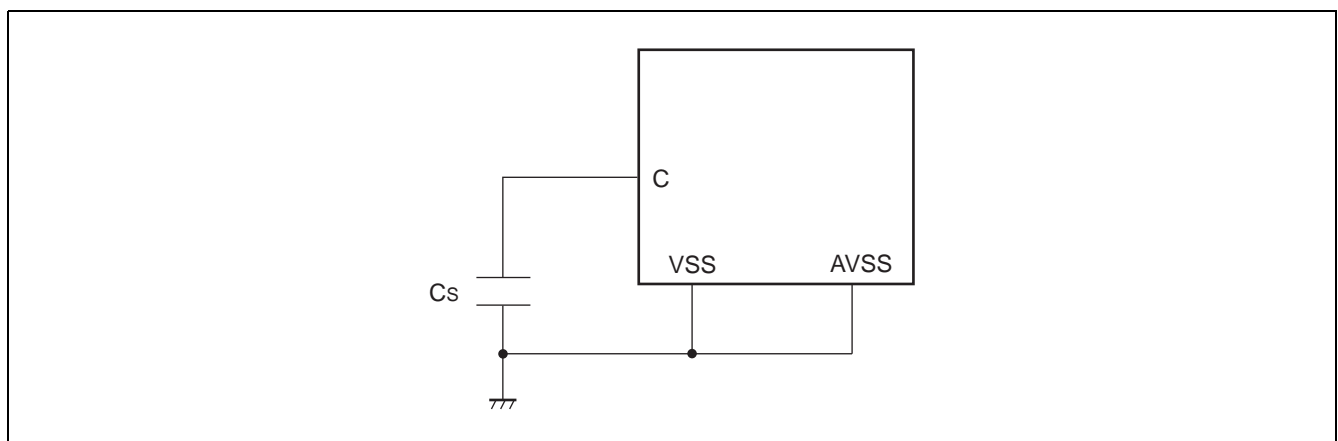

# MB91460N Series

## 3. DC characteristics

( $V_{CC} = 3.0\text{ V to }3.6\text{ V} / 4.5\text{ V to }5.5\text{ V}$ ,  $V_{SS} = AV_{SS} = 0\text{ V}$ ,  $T_A = -40\text{ }^\circ\text{C to }+105\text{ }^\circ\text{C} / -40\text{ }^\circ\text{C to }+85\text{ }^\circ\text{C}$ )

Parameter	Symbol	Pin name	Condition	Value			Unit	Remarks
				Min	Typ	Max		
“H” level input voltage	$V_{IHS}$	Port pin	When CMOS hysteresis input type1 are selected	$0.7 \times V_{CC}$	—	$V_{CC} + 0.3$	V	
	$V_{IHC}$	Port pin	When CMOS hysteresis input type2 are selected	$0.8 \times V_{CC}$	—	$V_{CC} + 0.3$	V	
	$V_{IHA}$	Port pin	When Automotive inputs are selected	$0.8 \times V_{CC}$	—	$V_{CC} + 0.3$	V	
	$V_{IHT}$	Port pin	When TTL input levels are selected	2.0	—	$V_{CC} + 0.3$	V	
	$V_{IH1}$	MD2 to MD0	CMOS level input	$0.7 \times V_{CC}$	—	$V_{CC} + 0.3$	V	
	$V_{IH2}$	MD3, INITX	CMOS hysteresis input	$0.7 \times V_{CC}$	—	$V_{CC} + 0.3$	V	
“L” level input voltage	$V_{ILS}$	Port pin	When CMOS hysteresis input type1 are selected	$V_{SS} - 0.3$	—	$0.3 \times V_{CC}$	V	
	$V_{ILC}$	Port pin	When CMOS hysteresis input type2 are selected	$V_{SS} - 0.3$	—	$0.2 \times V_{CC}$	V	
	$V_{ILA}$	Port pin	When Automotive inputs are selected	$V_{SS} - 0.3$	—	$0.5 \times V_{CC}$	V	
	$V_{ILT}$	Port pin	When TTL input levels are selected	$V_{SS} - 0.3$	—	0.8	V	
	$V_{IL1}$	MD2 to MD0	CMOS level input	$V_{SS} - 0.3$	—	$0.3 \times V_{CC}$	V	
	$V_{IL2}$	MD3, INITX	CMOS hysteresis input	$V_{SS} - 0.3$	—	$0.3 \times V_{CC}$	V	
“H” level output voltage	$V_{OH1}$	Port pin	$V_{CC} = 5.0\text{ V}$ , $I_{OH} = -2.0\text{ mA}$ / $V_{CC} = 3.3\text{ V}$ , $I_{OH} = -1.0\text{ mA}$	$V_{CC} - 0.5$	—	—	V	*1
	$V_{OH2}$	I <sup>2</sup> C common port pin	$V_{CC} = 5.0\text{ V}$ , $I_{OH} = -3.0\text{ mA}$ / $V_{CC} = 3.3\text{ V}$ , $I_{OH} = -3.0\text{ mA}$	$V_{CC} - 0.5$	—	—	V	
	$V_{OH3}$	Port pin	$V_{CC} = 5.0\text{ V}$ , $I_{OH} = -5.0\text{ mA}$ / $V_{CC} = 3.3\text{ V}$ , $I_{OH} = -3.0\text{ mA}$	$V_{CC} - 0.5$	—	—	V	*1

(Continued)

# MB91460N Series

( $V_{CC} = 3.0\text{ V to }3.6\text{ V} / 4.5\text{ V to }5.5\text{ V}$ ,  $V_{SS} = AV_{SS} = 0\text{ V}$ ,  $T_A = -40\text{ }^\circ\text{C to }+105\text{ }^\circ\text{C} / -40\text{ }^\circ\text{C to }+85\text{ }^\circ\text{C}$ )

Parameter	Symbol	Pin name	Condition	Value			Unit	Remarks
				Min	Typ	Max		
“L” level output voltage	$V_{OL1}$	Port pin	$V_{CC} = 5.0\text{ V}$ , $I_{OH} = -2.0\text{ mA}$ / $V_{CC} = 3.3\text{ V}$ , $I_{OH} = -1.0\text{ mA}$	—	—	0.4	V	*1
	$V_{OL2}$	I <sup>2</sup> C common port pin	$V_{CC} = 5.0\text{ V}$ , $I_{OH} = -3.0\text{ mA}$ / $V_{CC} = 3.3\text{ V}$ , $I_{OH} = -3.0\text{ mA}$	—	—	0.4	V	
	$V_{OL3}$	Port pin	$V_{CC} = 5.0\text{ V}$ , $I_{OH} = -5.0\text{ mA}$ / $V_{CC} = 3.3\text{ V}$ , $I_{OH} = -3.0\text{ mA}$	—	—	0.4	V	*1
Input leak current	$I_{IL}$	—	$V_{CC} = AV_{CC} = 5.0\text{ V}$ , $V_{SS} < V_I < V_{CC}$	-5	—	+5	$\mu\text{A}$	
Pull-up resistance value	$R_{UP}$	Port pin	—	25	50	100	$\text{k}\Omega$	
Pull-down resistance value	$R_{DOWN}$	Port pin	—	25	50	100	$\text{k}\Omega$	

(Continued)

# MB91460N Series

(Continued)

( $V_{CC} = 3.0\text{ V to }3.6\text{ V/ }4.5\text{ V to }5.5\text{ V}$ ,  $V_{SS} = AV_{SS} = 0\text{ V}$ ,  $T_A = -40\text{ }^\circ\text{C to }+105\text{ }^\circ\text{C}/-40\text{ }^\circ\text{C to }+85\text{ }^\circ\text{C}$ )

Parameter	Symbol	Pin name	Condition	Value			Unit	Remarks
				Min	Typ	Max		
Power supply current	I <sub>CC3</sub>	VCC	V <sub>CC</sub> = 3.3 V CPU core : 80 MHz,	—	75	102	mA	T <sub>A</sub> = -40 °C to +105 °C
	I <sub>CC5</sub>	VCC	V <sub>CC</sub> = 5.0 V CPU core : 80 MHz,	—	75	102	mA	T <sub>A</sub> = -40 °C to +85 °C
	I <sub>CCS3</sub>	VCC	V <sub>CC</sub> = 3.3 V sleep mode	—	15	45	mA	
	I <sub>CCS5</sub>	VCC	V <sub>CC</sub> = 5.0 V sleep mode	—	15	45	mA	
	I <sub>CTS3</sub>	VCC	V <sub>CC</sub> = 3.3 V stop mode (at using RTC) *3	—	100	550	μA	T <sub>A</sub> = +25 °C When the CR oscillator is operating and low voltage detection is enabled.
	I <sub>CTS5</sub>	VCC	V <sub>CC</sub> = 5.0 V stop mode (at using RTC) *3	—	200	650	μA	T <sub>A</sub> = +25 °C When the CR oscillator is operating and low voltage detection is enabled.
	I <sub>CH3</sub>	VCC	V <sub>CC</sub> = 3.3 V stop mode (oscillation stop) *4	—	100	500	μA	T <sub>A</sub> = +25 °C When the CR oscillator is stopping and low voltage detection is enabled.
	I <sub>CH5</sub>	VCC	V <sub>CC</sub> = 5.0 V stop mode (oscillation stop) *4	—	150	600	μA	T <sub>A</sub> = +25 °C When the CR oscillator is stopping and low voltage detection is enabled.
	I <sub>CCF</sub>	VCC	Flash programming (Write/Erase)	—	25	50	mA	*2
Input capacitance	C <sub>IN</sub>	Except VCC, AVCC, VSS, AVSS	—	5	15	pF		

\*1 : The drive power varies depending on the power supply voltage (3.3 V, 5.0 V).

\*2 : The power supply current when writing or erasing by executing the automatic algorithm.

\*3 : When the main clock oscillator is stopped and CR oscillator is operating (using the CR oscillator clock in the RTC) and the low voltage detection is enabled.

\*4 : When the main clock oscillator is stopped, the CR oscillator is stopped and the low voltage detection is enabled.

## 4. AC characteristics

### (1) Clock timing

( $V_{CC} = 3.0\text{ V to }3.6\text{ V} / 4.5\text{ V to }5.5\text{ V}$ ,  $V_{SS} = AV_{SS} = 0\text{ V}$ ,  $T_A = -40\text{ }^\circ\text{C to }+125\text{ }^\circ\text{C} / -40\text{ }^\circ\text{C to }+85\text{ }^\circ\text{C}$ )

Parameter	Symbol	Pin name	Condition	Value			Unit	Remarks
				Min	Typ	Max		
Clock frequency	F <sub>C</sub>	X0, X1	—	3.5	4	16	MHz	When using the oscillator circuit
				3.5	—	32	MHz	When using an external clock
Clock cycle time	t <sub>c</sub>	X0, X1		62.5	—	285.7	ns	When using the oscillator circuit
				31.25	—	285.7	ns	When using an external clock
Internal operation clock frequency	F <sub>CP</sub>	—		—	—	80	MHz	CPU clock, when using PLL*
	F <sub>CPP</sub>	—		—	—	40	MHz	Peripheral clock
Internal operation clock cycle time	t <sub>CP</sub>	—		12.5	—	—	ns	CPU clock, when using PLL
	t <sub>CPP</sub>	—		25	—	—	ns	Peripheral clock
Input clock pulse width	P <sub>WH</sub> , P <sub>WL</sub>	X0		30	—	—	ns	
Input clock rise/fall time	t <sub>cf</sub> , t <sub>cr</sub>	X0		—	—	5	ns	

\* : When using the clock modulator, set such that the maximum value of the modulated frequency is 96 MHz or less.

### • Clock timing

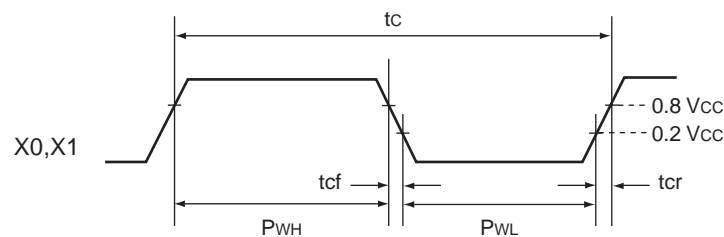

# MB91460N Series

## (2) Reset input

( $V_{CC} = 3.0\text{ V to }3.6\text{ V} / 4.5\text{ V to }5.5\text{ V}$ ,  $V_{SS} = AV_{SS} = 0\text{ V}$ ,  $T_A = -40\text{ }^\circ\text{C to }+105\text{ }^\circ\text{C} / -40\text{ }^\circ\text{C to }+85\text{ }^\circ\text{C}$ )

Parameter	Symbol	Pin name	Condition	Value		Unit
				Min	Max	
INITX input time (at power-on or stop mode)	$t_{INTL}$	INITX	—	Oscillation stabilization time of oscillator + 2.6	—	ms
INITX input time (other than the above)				20	—	$\mu\text{s}$

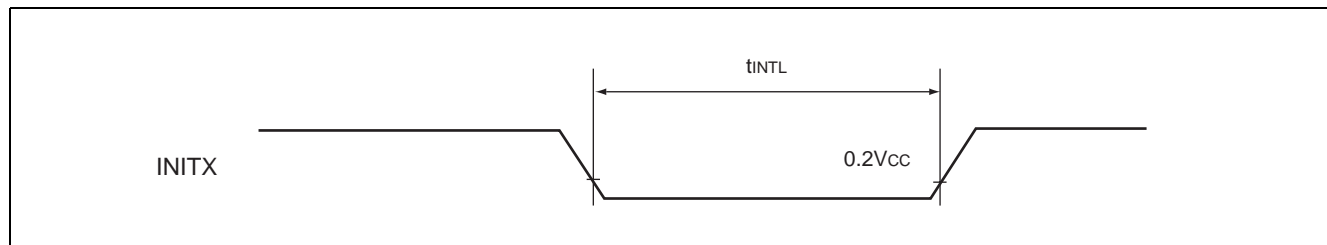

## (3) Specification for power-on

( $V_{CC} = 3.0\text{ V to }3.6\text{ V} / 4.5\text{ V to }5.5\text{ V}$ ,  $V_{SS} = AV_{SS} = 0\text{ V}$ ,  $T_A = -40\text{ }^\circ\text{C to }+105\text{ }^\circ\text{C} / -40\text{ }^\circ\text{C to }+85\text{ }^\circ\text{C}$ )

Parameter	Symbol	Pin name	Condition	Value		Unit
				Min	Max	
Power supply rising time	$t_R$	VCC	—	0.1	100	ms
Power supply start time	—	—	—	0.2	—	V
Power supply end time	—	—	—	—	$0.9 \times V_{CC}$	V

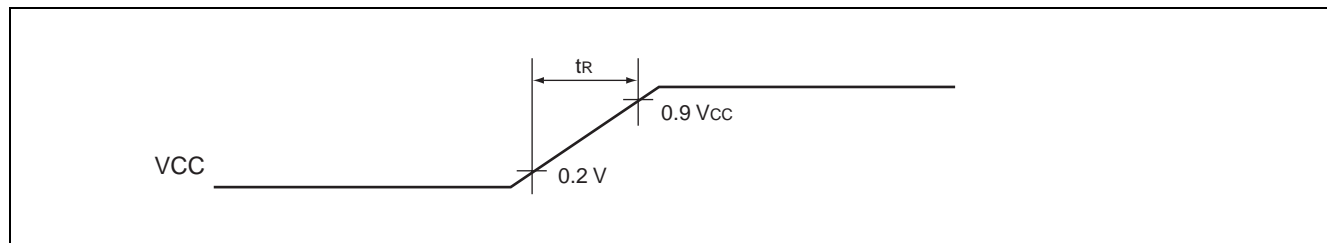

## (4) LIN-USART timing

( $V_{CC} = 3.0\text{ V to }3.6\text{ V/ }4.5\text{ V to }5.5\text{ V}$ ,  $V_{SS} = AV_{SS} = 0\text{ V}$ ,  $T_A = -40\text{ }^\circ\text{C to }+105\text{ }^\circ\text{C/-}40\text{ }^\circ\text{C to }+85\text{ }^\circ\text{C}$ )

Parameter	Symbol	Pin name	Condition	Value		Unit
				Min	Max	
Serial clock cycle time	$t_{SCYC}$	SCK0 to SCK3	Internal shift clock mode	$8 \times t_{CLKP}$	—	ns
SCK ↓ → SOT delay time	$t_{SLOV}$	SCK0 to SCK3, SOT0 to SOT3		- 80	+ 80	ns
Valid SIN → SCK ↑	$t_{IVSH}$	SCK0 to SCK3, SIN0 to SIN3		100	—	ns
SCK ↑ → valid SIN hold time	$t_{SHIX}$	SCK0 to SCK3, SIN0 to SIN3		60	—	ns
Serial clock "H" pulse width	$t_{SHSL}$	SCK0 to SCK3	External shift clock mode	$4 \times t_{CLKP}$	—	ns
Serial clock "L" pulse width	$t_{SLSH}$	SCK0 to SCK3		$4 \times t_{CLKP}$	—	ns
SCK ↓ → SOT delay time	$t_{SLOV}$	SCK0 to SCK3, SOT0 to SOT3		—	150	ns
Valid SIN → SCK ↑	$t_{IVSH}$	SCK0 to SCK3, SIN0 to SIN3		60	—	ns
SCK ↑ → Valid SIN hold time	$t_{SHIX}$	SCK0 to SCK3, SIN0 to SIN3		60	—	ns

Notes : • Above values are AC characteristics for CLK synchronous mode.  
•  $t_{CLKP}$  is the cycle time of the peripheral clock.

# MB91460N Series

- Internal shift clock mode

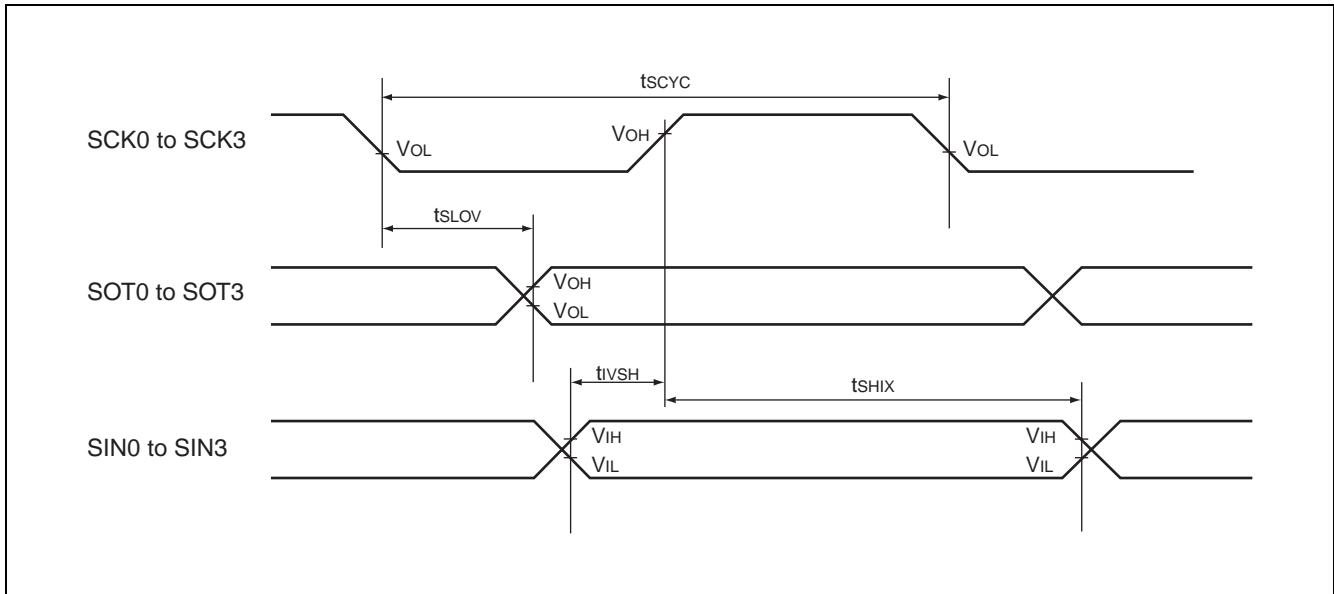

- External shift clock mode

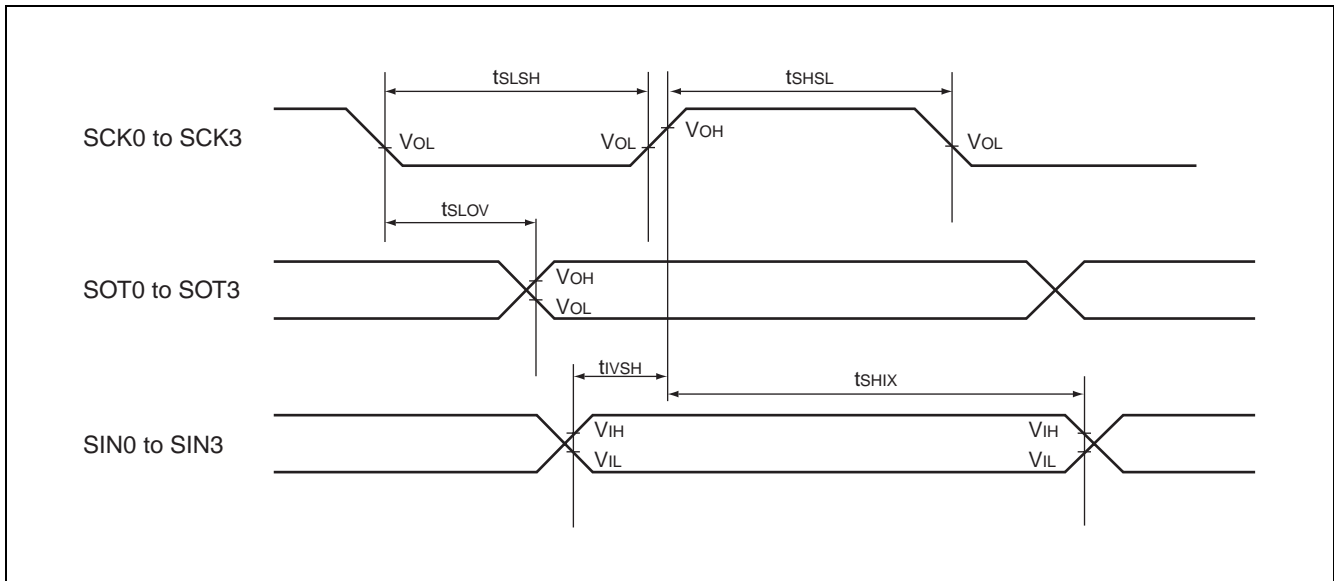

## (5) Trigger input timing

( $V_{CC} = 3.0\text{ V to }3.6\text{ V} / 4.5\text{ V to }5.5\text{ V}$ ,  $V_{SS} = AV_{SS} = 0\text{ V}$ ,  $T_A = -40\text{ }^\circ\text{C to }+105\text{ }^\circ\text{C} / -40\text{ }^\circ\text{C to }+85\text{ }^\circ\text{C}$ )

Parameter	Symbol	Pin name	Value		Unit
			Min	Max	
External interrupt input pulse width	$t_{TRGH}$ $t_{TRGL}$	INT0 to INT7 INT12, INT13	$4 \times t_{CLKP}$	—	ns

Note :  $t_{CLKP}$  is the cycle time of the peripheral clock.

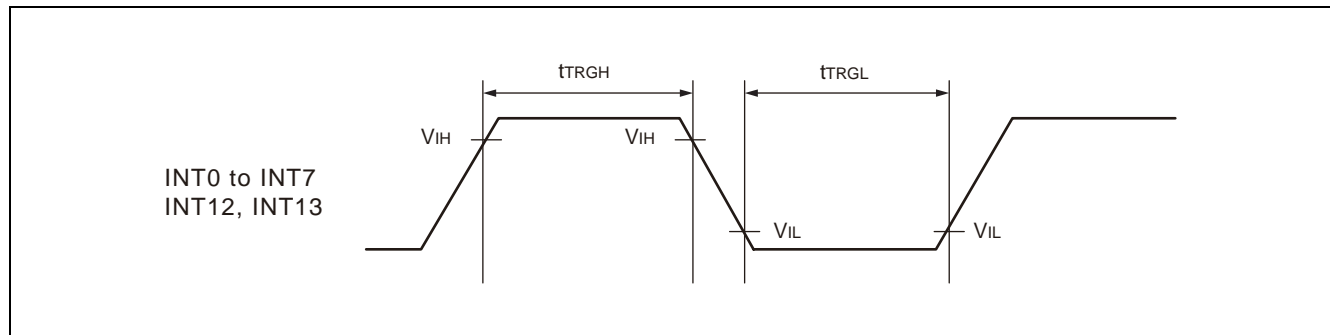

## (6) Timer related resource input timing

( $V_{CC} = 3.0\text{ V to }3.6\text{ V} / 4.5\text{ V to }5.5\text{ V}$ ,  $V_{SS} = AV_{SS} = 0\text{ V}$ ,  $T_A = -40\text{ }^\circ\text{C to }+105\text{ }^\circ\text{C} / -40\text{ }^\circ\text{C to }+85\text{ }^\circ\text{C}$ )

Parameter	Symbol	Pin name	Value		Unit
			Min	Max	
Free-run timer input clock pulse width	$t_{TIWH}$ $t_{TIWL}$	CK0 to CK3	$4 \times t_{CLKP}$	—	ns
Up/down counter input pulse width		AIN0, AIN1 BIN0, BIN1 ZIN0, ZIN1	$4 \times t_{CLKP}$	—	ns
Reload timer input pulse width		TIN0 to TIN3	$4 \times t_{CLKP}$	—	ns
Input capture input pulse width		ICU0 to ICU3	$4 \times t_{CLKP}$	—	ns

Note :  $t_{CLKP}$  is the cycle time of the peripheral clock.

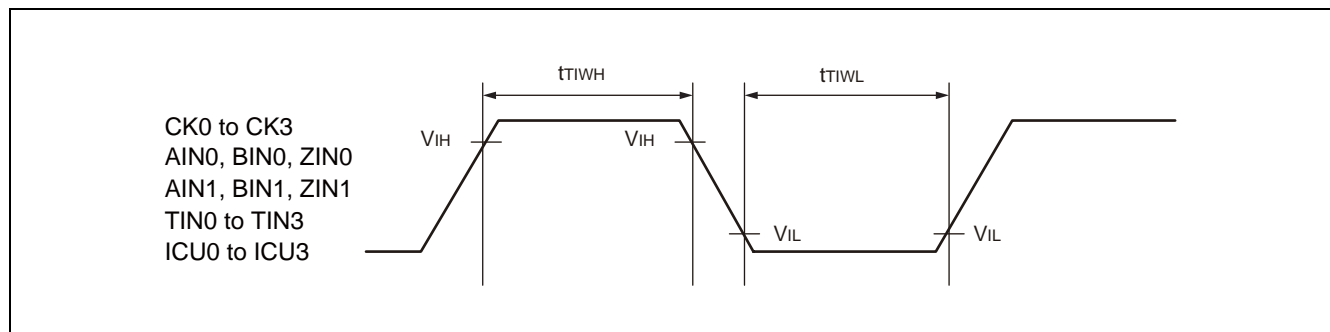

# MB91460N Series

## (7) I<sup>2</sup>C timing

(V<sub>CC</sub> = 3.0 V to 3.6 V / 4.5 V to 5.5 V, V<sub>SS</sub> = AV<sub>SS</sub> = 0 V, T<sub>A</sub> = -40 °C to +105 °C / -40 °C to +85 °C)

Parameter	Symbol	Pin name	Condition	Standard Mode		Fast Mode *1		Unit
				Min	Max	Min	Max	
SCL clock frequency	f <sub>SCL</sub>			0	100	0	400	kHz
"L" width of the SCL clock	t <sub>LOW</sub>			4.7	—	1.3	—	μs
"H" width of the SCL clock	t <sub>HIGH</sub>			4.0	—	0.6	—	μs
Bus free time between STOP and START conditions	t <sub>BUS</sub>			4.7	—	1.3	—	μs
SCL ↑ → SDA output delay time	t <sub>DLDAT</sub>			—	5 × t <sub>CLKP</sub>	—	5 × t <sub>CLKP</sub>	ns
Setup time for a repeated START condition SCL ↑ → SDA ↓	t <sub>SUSTA</sub>	SDA2, SDA3, SCL2, SCL3	R = 1 kΩ, C = 50 pF <sup>*2</sup>	4.7	—	0.6	—	μs
Hold time for a repeated START condition SDA ↓ → SCL ↓	t <sub>HDSTA</sub>			4.0	—	0.6	—	μs
Setup time for STOP condition SCL ↑ → SDA ↑	t <sub>SUSTO</sub>			4.0	—	0.6	—	μs
SDA data input hold time SCL ↓ → SDA ↓ ↑	t <sub>HDDAT</sub>			2 × t <sub>CLKP</sub>	—	2 × t <sub>CLKP</sub>	—	μs
SDA data input setup time SDA ↓ ↑ → SCL ↑	t <sub>SUDAT</sub>			250	—	100	—	ns

\*1 : For use at over 100 kHz, set the peripheral clock to at least 6 MHz.

\*2 : R and C are the pull-up resistance and load capacitance of the SCL and SDA lines.

Note : t<sub>CLKP</sub> is the cycle time of the peripheral clock.

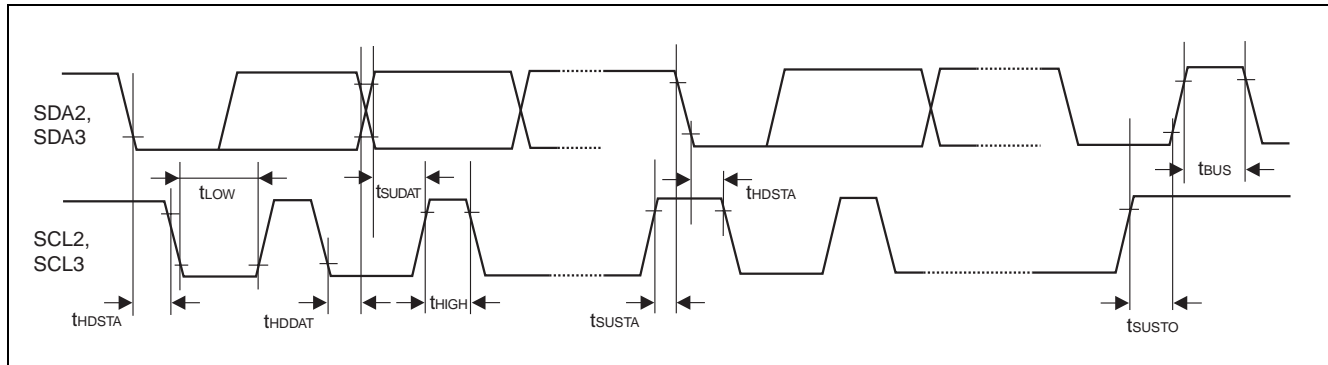

## 5. Electrical characteristics for A/D converter

( $V_{CC} = 3.0\text{ V to }3.6\text{ V/ }4.5\text{ V to }5.5\text{ V}$ ,  $V_{SS} = AV_{SS} = 0\text{ V}$ ,  $T_A = -40\text{ }^\circ\text{C to }+105\text{ }^\circ\text{C}/-40\text{ }^\circ\text{C to }+85\text{ }^\circ\text{C}$ )

Parameter	Symbol	Pin name	Value			Unit	Remarks
			Min	Typ	Max		
Resolution	—	—	—	—	10	bit	
Total error*1	—	—	—	—	$\pm 3$	LSB	
Linearity error*1	—	—	—	—	$\pm 2.5$	LSB	
Differential linearity error*1	—	—	—	—	$\pm 1.9$	LSB	
Zero transition voltage*1	$V_{OT}$	AN0 to AN7	$AV_{SS}-1.5\text{ LSB}$	$AV_{SS}-0.5\text{ LSB}$	$AV_{SS}-2.5\text{ LSB}$	V	
Full scale transition voltage*1	$V_{FST}$	AN0 to AN7	$AVRH-3.5\text{ LSB}$	$AVRH-1.5\text{ LSB}$	$AVRH-0.5\text{ LSB}$	V	
Conversion time	—	—	1 *2	—	—	$\mu\text{s}$	Using at 5 V
			3 *2	—	—	$\mu\text{s}$	Using at 3.3 V
Analog port input current	$I_{AIN}$	AN0 to AN7	—	—	10	$\mu\text{A}$	
Analog input voltage	$V_{AIN}$	AN0 to AN7	$AV_{SS}$	—	$AVRH$	V	
Reference voltage	—	$AVRH$	$AV_{SS}$	—	$AV_{CC}$	V	
Analog power supply current (analog + digital)	$I_A$	$AV_{CC}$	—	2.4	4.7	mA	Including reference supply
Reference voltage supply current	$I_R$	$AVRH$	—	0.65	1.0	mA	
Analog input equivalent capacitance	$C_{in}$	AN0 to AN7	—	—	8.5	pF	
Analog input equivalent resistance	$R_{in}$	AN0 to AN7	—	—	2.6	k $\Omega$	$AV_{CC} \geq 4.5\text{ V}$
			—	—	12.1	k $\Omega$	$AV_{CC} \geq 3.0\text{ V}$
Output impedance of analog signal source	$R_{ext}$	—	—	—	4.2	k $\Omega$	

\*1 : Measured in the CPU sleep state

\*2 : Set no shorter than this time period in the peripheral clock and conversion setting register.

# MB91460N Series

## Notes on the A/D Converter

The diagram below shows the equivalent circuit of the sampling circuit in the A/D converter.

Apply the output impedance in the external circuit for the analog output under the following conditions.

- The recommended output impedance for the external circuit is 4.2 kΩ or less.
- If an external capacitor is used, remember to consider the capacitive voltage divider effect due to the external capacitor and the internal capacitor in the chip. Accordingly, an external capacitance several thousand times that of the internal capacitance is recommended.
- The analog voltage sampling period may be too short if the output impedance of the external circuit is high. In this case, select  $R_{ext}$  and  $T_{smp}$  to satisfy the following condition.

$$R_{ext} = T_{smp} / (7 \times C_{in}) - R_{in}$$

$R_{ext}$  : Output impedance of the analog signal source

$T_{smp}$  : Sampling time

$C_{in}$  : Equivalent capacitance of analog input

$R_{in}$  : Equivalent resistance of analog input

### • Input impedance

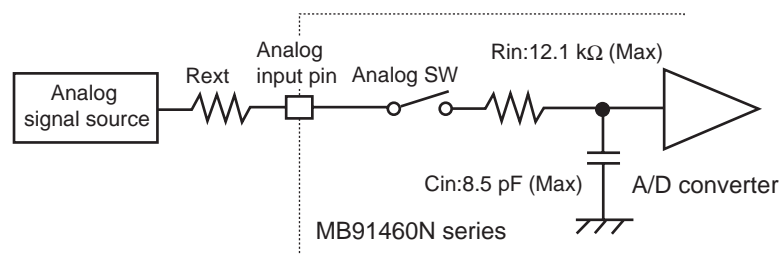

### Definition of A/D converter terms

- Resolution  
Analog variation that is recognizable by an A/D converter.
- Linearity error  
Deviation between actual conversion characteristics and a straight line connecting zero transition point (00 0000 0000 ↔ 00 0000 0001) and full scale transition point (11 1111 1110 ↔ 11 1111 1111).
- Differential linearity error  
Deviation of input voltage, which is required for changing output code by 1 LSB, from an ideal value.
- Total error  
This error indicates the difference between actual and theoretical values, including the zero transition error/full scale transition error/linearity error.

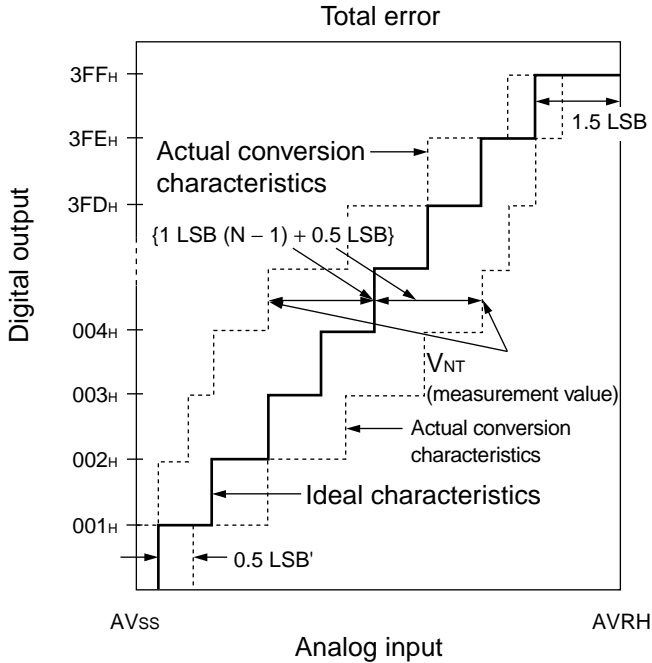

$$1\text{LSB}' \text{ (ideal value)} = \frac{\text{AVRH} - \text{AVSS}}{1024} \text{ [V]}$$

$$\text{Total error of digital output } N = \frac{V_{\text{NT}} - \{1 \text{ LSB}' \times (N - 1) + 0.5 \text{ LSB}'\}}{1 \text{ LSB}'}$$

- N : A/D converter digital output value
- $V_{0T}'$  (ideal value) =  $\text{AVSS} + 0.5 \text{ LSB}'$  [V]
- $V_{FST}'$  (ideal value) =  $\text{AVRH} - 1.5 \text{ LSB}'$  [V]
- $V_{\text{NT}}$  : A voltage at which digital output transits from  $(N + 1)_H$  to  $N_H$

(Continued)

(Continued)

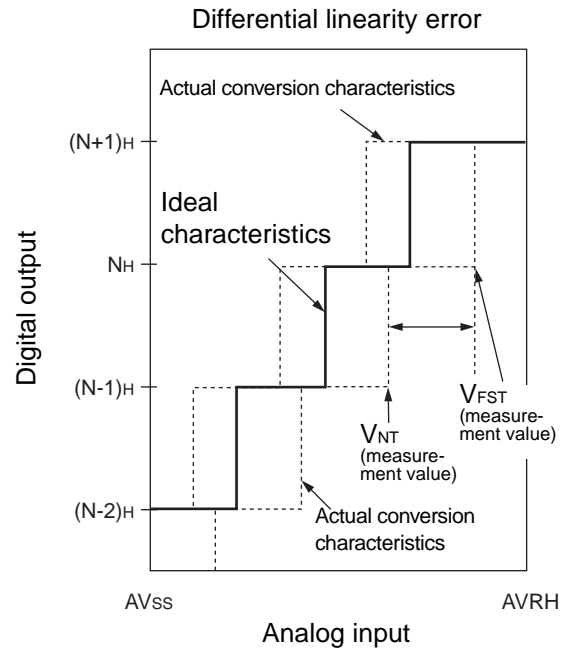
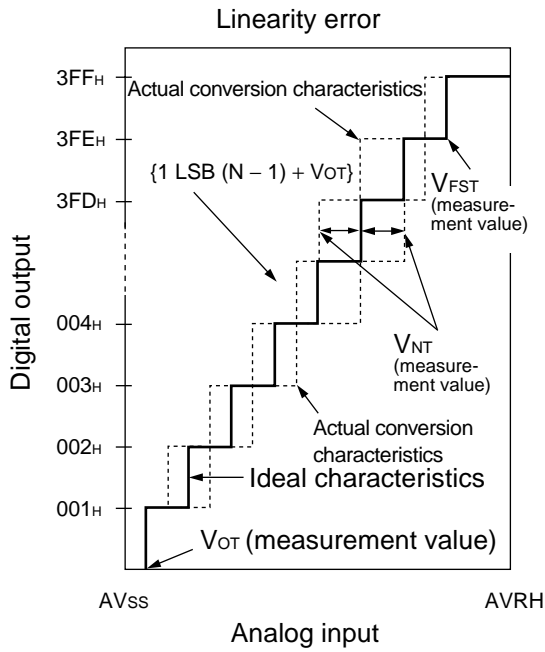

$$\text{Linearity error of digital output } N = \frac{V_{NT} - \{1\text{LSB} \times (N - 1) + V_{OT}\}}{1\text{LSB}} [\text{LSB}]$$

$$\text{Differential linearity error of digital output } N = \frac{V_{(N+1)T} - V_{NT}}{1\text{LSB}} [\text{LSB}]$$

$$1\text{LSB} = \frac{V_{FST} - V_{OT}}{1022} [\text{V}]$$

N : A/D converter digital output value

$V_{OT}$  : A voltage at which digital output transits from 000<sub>H</sub> to 001<sub>H</sub>.

$V_{FST}$  : A voltage at which digital output transits from 3FE<sub>H</sub> to 3FF<sub>H</sub>.

• Flash Memory Program/Erase Characteristics

Parameter	Conditions	Value			Unit	Remarks
		Min	Typ	Max		
Sector erase time	T <sub>A</sub> = + 25 °C V <sub>CC</sub> = 5.0 V	—	0.9	3.6	s	Excludes programming prior to erasure
Chip erase time		—	9	—	s	Excludes programming prior to erasure
Word (16-bit width) programming time		—	23	370	μs	Except for the overhead time of the system level
Program/Erase cycle	—	10000	—	—	cycle	
Flash memory data retention time	Average T <sub>A</sub> = + 85 °C	20	—	—	year	*

\* : The value is translated high-temperature measurement results of the technology reliability evaluation into average value at + 85 °C.

# MB91460N Series

## ■ ORDERING INFORMATION

Part number	Package	Remarks
MB91F463NBPMC	64-pin plastic LQFP (FPT-64P-M23)	Lead-free package

## ■ PACKAGE DIMENSION

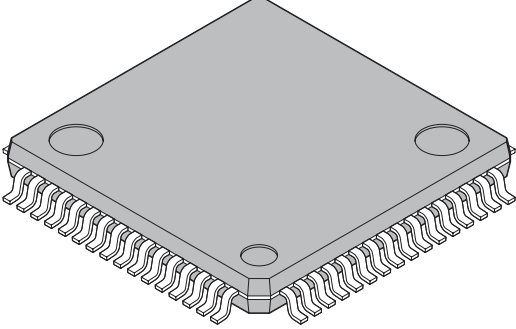
<p>64-pin plastic LQFP</p>  <p>(FPT-64P-M23)</p>	Lead pitch	0.65 mm
	Package width × package length	12.0 × 12.0 mm
	Lead shape	Gullwing
	Sealing method	Plastic mold
	Mounting height	1.70 mm MAX
	Code (Reference)	P-LFQFP64-12×12-0.65

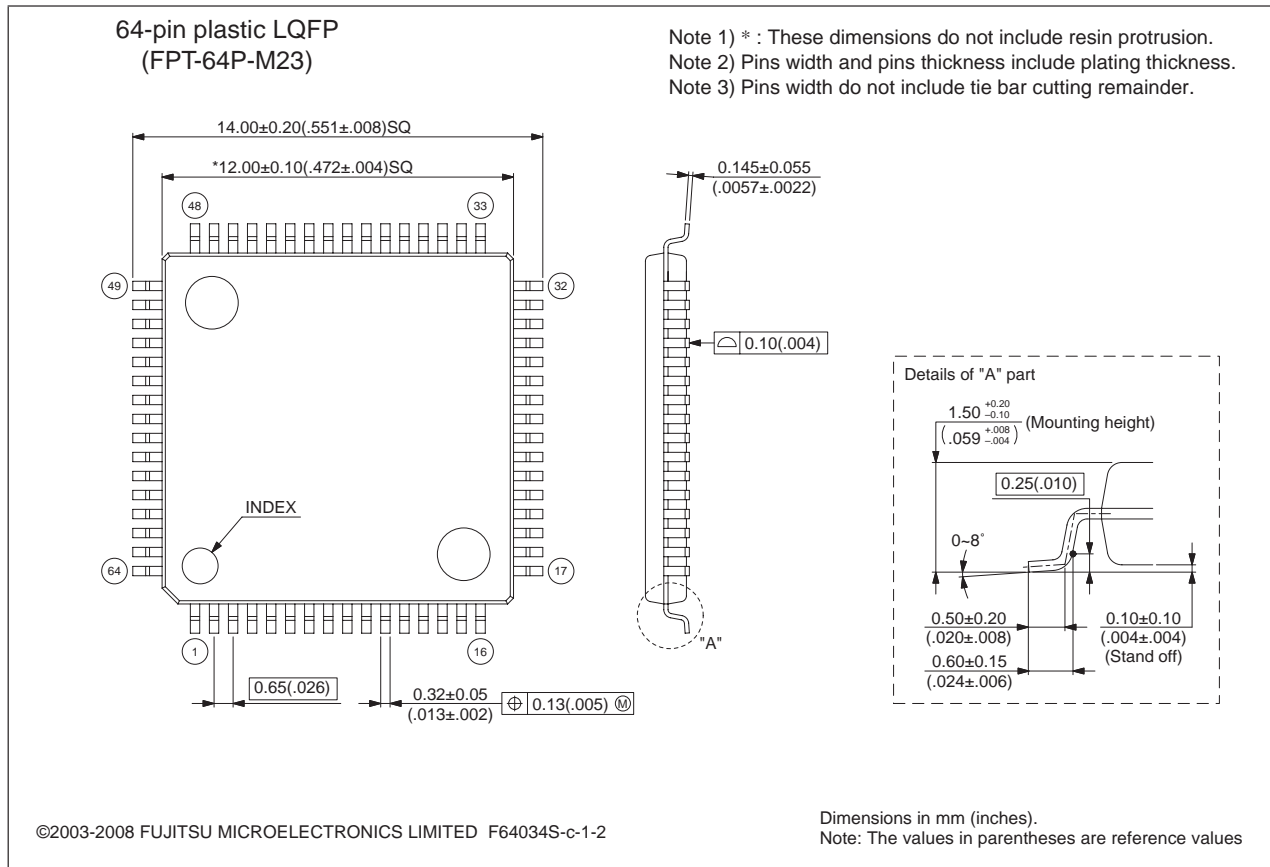

Please confirm the latest Package dimension by following URL.  
<http://edevice.fujitsu.com/package/en-search/>

# MB91460N Series

## ■ MAIN CHANGES IN THIS EDITION

Page	Section	Change Results
—	—	RC oscillator and R/C oscillator → CR oscillator
2	<b>■ FEATURES</b> • Internal peripheral resources • DMAC (DMA Controller)	Deleted the demand transfer in “Transfer mode”.
6	<b>■ PIN ASSIGNMENT</b>	Changed No.13 of pin name. P24_3/INT3 → P24_3/INT3/MONCLK
7	<b>■ PIN DESCRIPTION</b>	Added the “MONCLK” of Pin no.13.
12, 13	<b>■ I/O CIRCUIT TYPE</b>	Deleted the I/O circuit type (Type D, E, F, K, L, M, N).
		Changed the figure of the circuit form of type I.
		Changed the figure of the circuit form of type J.
25	<b>■ CPU AND CONTROL UNIT</b>	Changed the initial value of CCR (Condition Code Register) . --00XXXX → -000XXXX
47	<b>■ I/O MAP</b>	Changed the content of Addresses (000DD6 <sub>H</sub> , 000DD8 <sub>H</sub> , and 000DDD <sub>H</sub> ) . EPFR22, EPFR24, EPFR29 → Reserved
50		Changed the content of Addresses (00B000 <sub>H</sub> to 00BFFC <sub>H</sub> ). Boot ROM → BI ROM
63	<b>■ ELECTRICAL CHARACTERISTICS</b> 1. Absolute maximum rating	Added note *3.
66	<b>■ ELECTRICAL CHARACTERISTICS</b> 3. DC characteristics	Changed the “H” level input voltage and “L” level input voltage (CMOS input levels → CMOS hysteresis input type1 CMOS hysteresis inputs → CMOS hysteresis input type2 ) Added the “CMOS level input (V <sub>IH1</sub> , V <sub>IL1</sub> )” and “CMOS hysteresis input (V <sub>IH2</sub> , V <sub>IL2</sub> )”.
72	<b>■ ELECTRICAL CHARACTERISTICS</b> 4. AC characteristics (4) LIN-USART timing	Changed the symbol of SIN0 to SIN3. V <sub>OH</sub> → V <sub>IH</sub> V <sub>OL</sub> → V <sub>IL</sub>
75, 77, 78	<b>■ ELECTRICAL CHARACTERISTICS</b> 5. Electrical characteristics for A/D converter	Changed the items of “Zero transition voltage” and “Full scale transition voltage”. Parameter : Non linearity error → Linearity error Differential non linearity error → Differential linearity error Full transition voltage → Full scale transition voltage Unit : LSB → V Value : Value → AV <sub>SS</sub> ± value LSB Value : AVR <sub>H</sub> ± value → AVR <sub>H</sub> ± value LSB

The vertical lines marked in the left side of the page show the changes.

**MEMO**

# MB91460N Series

## FUJITSU MICROELECTRONICS LIMITED

Shinjuku Dai-Ichi Seimei Bldg., 7-1, Nishishinjuku 2-chome,  
Shinjuku-ku, Tokyo 163-0722, Japan  
Tel: +81-3-5322-3347 Fax: +81-3-5322-3387  
<http://jp.fujitsu.com/fml/en/>

*For further information please contact:*

### North and South America

FUJITSU MICROELECTRONICS AMERICA, INC.  
1250 E. Arques Avenue, M/S 333  
Sunnyvale, CA 94085-5401, U.S.A.  
Tel: +1-408-737-5600 Fax: +1-408-737-5999  
<http://www.fma.fujitsu.com/>

### Asia Pacific

FUJITSU MICROELECTRONICS ASIA PTE. LTD.  
151 Lorong Chuan,  
#05-08 New Tech Park 556741 Singapore  
Tel : +65-6281-0770 Fax : +65-6281-0220  
<http://www.fmal.fujitsu.com/>

### Europe

FUJITSU MICROELECTRONICS EUROPE GmbH  
Pittlerstrasse 47, 63225 Langen, Germany  
Tel: +49-6103-690-0 Fax: +49-6103-690-122  
<http://emea.fujitsu.com/microelectronics/>

### FUJITSU MICROELECTRONICS SHANGHAI CO., LTD.

Rm. 3102, Bund Center, No.222 Yan An Road (E),  
Shanghai 200002, China  
Tel : +86-21-6146-3688 Fax : +86-21-6335-1605  
<http://cn.fujitsu.com/fmc/>

### Korea

FUJITSU MICROELECTRONICS KOREA LTD.  
206 Kosmo Tower Building, 1002 Daechi-Dong,  
Gangnam-Gu, Seoul 135-280, Republic of Korea  
Tel: +82-2-3484-7100 Fax: +82-2-3484-7111  
<http://kr.fujitsu.com/fmk/>

### FUJITSU MICROELECTRONICS PACIFIC ASIA LTD.

10/F., World Commerce Centre, 11 Canton Road,  
Tsimshatsui, Kowloon, Hong Kong  
Tel : +852-2377-0226 Fax : +852-2376-3269  
<http://cn.fujitsu.com/fmc/en/>

Specifications are subject to change without notice. For further information please contact each office.

### All Rights Reserved.

The contents of this document are subject to change without notice.

Customers are advised to consult with sales representatives before ordering.

The information, such as descriptions of function and application circuit examples, in this document are presented solely for the purpose of reference to show examples of operations and uses of FUJITSU MICROELECTRONICS device; FUJITSU MICROELECTRONICS does not warrant proper operation of the device with respect to use based on such information. When you develop equipment incorporating the device based on such information, you must assume any responsibility arising out of such use of the information.

FUJITSU MICROELECTRONICS assumes no liability for any damages whatsoever arising out of the use of the information.

Any information in this document, including descriptions of function and schematic diagrams, shall not be construed as license of the use or exercise of any intellectual property right, such as patent right or copyright, or any other right of FUJITSU MICROELECTRONICS or any third party or does FUJITSU MICROELECTRONICS warrant non-infringement of any third-party's intellectual property right or other right by using such information. FUJITSU MICROELECTRONICS assumes no liability for any infringement of the intellectual property rights or other rights of third parties which would result from the use of information contained herein.

The products described in this document are designed, developed and manufactured as contemplated for general use, including without limitation, ordinary industrial use, general office use, personal use, and household use, but are not designed, developed and manufactured as contemplated (1) for use accompanying fatal risks or dangers that, unless extremely high safety is secured, could have a serious effect to the public, and could lead directly to death, personal injury, severe physical damage or other loss (i.e., nuclear reaction control in nuclear facility, aircraft flight control, air traffic control, mass transport control, medical life support system, missile launch control in weapon system), or (2) for use requiring extremely high reliability (i.e., submersible repeater and artificial satellite).

Please note that FUJITSU MICROELECTRONICS will not be liable against you and/or any third party for any claims or damages arising in connection with above-mentioned uses of the products.

Any semiconductor devices have an inherent chance of failure. You must protect against injury, damage or loss from such failures by incorporating safety design measures into your facility and equipment such as redundancy, fire protection, and prevention of over-current levels and other abnormal operating conditions.

Exportation/release of any products described in this document may require necessary procedures in accordance with the regulations of the Foreign Exchange and Foreign Trade Control Law of Japan and/or US export control laws.

The company names and brand names herein are the trademarks or registered trademarks of their respective owners.