



VDE APPROVED
ZERO-CROSSING TRIACS



ZERO-CROSSING 30 mA MCP3030* MCP3040/OZ*
15 mA MCP3031 MCP3041/1Z
MCP3032 MCP3042/2Z

PACKAGE DIMENSIONS

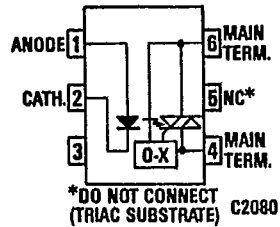
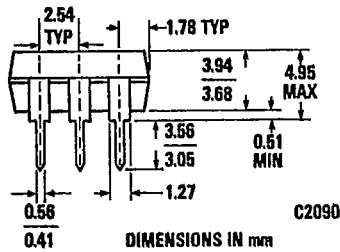
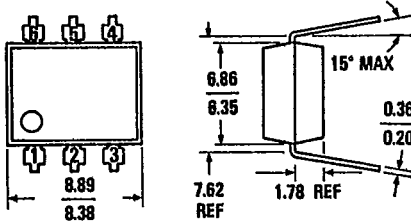

Equivalent Circuit

DESCRIPTION

These devices are optically isolated zero-crossing triac drivers. They consist of a Gallium Arsenide infrared emitting diode optically coupled to a photosensitive silicon detector which functions as a zero voltage crossing bilateral triac driver. This series is designed for interfacing between electronic controls, motors, solenoids and consumer appliances, etc.

FEATURES

- Logic control for 110 VAC or 220 VAC Power
- High isolation voltage — minimum 7500 VAC peak
- Underwriters Laboratory (UL) recognized File #E50151
- Pin for pin replacement for the MOC3030, MOC3031, MOC3040, MCP3041
- Excellent I_{FT} stability — IR emitting diode has low degradation.

APPLICATIONS

- Triac driver
- Industrial controls
- Solid state relay
- Traffic lights
- Motor controls
- Home appliances

*Not Recommended For New Designs

ABSOLUTE MAXIMUM RATINGS ($T_A=25^\circ\text{C}$ Unless Otherwise Specified)

TOTAL PACKAGE

Storage temperature -55°C to 150°C
 Operating temperature -40°C to 100°C
 Lead temperature (Soldering, 10 sec) 260°C
 Total package power dissipation
 @ 25°C (LED plus detector) 330 mW
 Derate linearly from 25°C $4.0 \text{ mW}/^\circ\text{C}$
 Surge Isolation voltage 7500 VAC Peak
 Withstand test voltage .. 7500 VAC Peak (50-60Hz)

INPUT DIODE

Forward DC current 60 mA
 Reverse voltage 6 V
 Peak forward current (1 μs pulse, 300 pps) ... 3.0 A
 Power dissipation 25°C ambient 100 mW
 Derate linearly from 25°C $1.33 \text{ mW}/^\circ\text{C}$

OUTPUT DRIVER

Off-State Output Terminal Voltage
 MCP3030, MCP3031 250 V
 MCP3040, MCP3041 400 V
 On-State RMS Current $T_A=25^\circ\text{C}$ 100 mA
 (Full Cycle, 50 to 60 Hz) $T_A=70^\circ\text{C}$ 50 mA
 Peak Nonrepetitive Surge Current
 (PW=10 ms, DC=10%) 1.2 A
 Total Power Dissipation @ $T_A=25^\circ\text{C}$ 300 mW
 Derate above 25°C $4.0 \text{ mW}/^\circ\text{C}$

MCP3030* MCP3031 MCP3032 MCP3040/OZ* MCP3041/1Z MCP3042/2Z



**VDE APPROVED
ZERO-CROSSING TRIACS**

T-41-87

ELECTRO-OPTICAL CHARACTERISTICS ($T_A=25^\circ\text{C}$ Unless Otherwise Specified)

INDIVIDUAL COMPONENT CHARACTERISTICS

CHARACTERISTIC	SYMBOL	MIN.	TYP.	MAX.	UNITS	TEST CONDITIONS
INPUT DIODE						
Forward voltage	V_F		1.3	1.50	V	$I_F=30\text{ mA}$
Forward voltage temp. coefficient	$\frac{\Delta V_F}{\Delta T_A}$		-1.8		mV/°C	
Reverse voltage	V_R	3.0	25		V	$I_R=10\ \mu\text{A}$
Junction capacitance	C_J		50	65	pF	$V_F=0\text{ V}, f=1\text{ MHz}$ $V_F=1\text{ V}, f=1\text{ MHz}$
OUTPUT DETECTOR						
Peak blocking current, either direction						
MCP3030, MCP3031	I_{DRM1}		2	100	nA	$V_{DRM}=250\text{ V}$, Note 1
MCP3040, MCP3041	I_{DRM1}		2	1009	nA	$V_{DRM}=400\text{ V}$, Note 1
Peak on-state voltage, either direction	V_{TM}		1.8	3.0	Volts	$I_{TM}=100\text{ mA Peak}$
Critical rate of rise of off-state voltage	dV/dt		1000		V/ μs	
Note 1. Test voltage must be applied within dV/dt rating.						

CAUTION: Normal anti-static precautions are required when handling this product.

TRANSFER CHARACTERISTICS

DC CHARACTERISTICS	SYMBOL	MIN.	TYP.	MAX.	UNITS	TEST CONDITIONS
LED trigger current (current required to latch output)						
MCP3030, MCP3040	I_{FT}		16	30	mA	Main terminal voltage=3.0 V
MCP3031, MCP3041	I_{FT}		7	15	mA	
Holding current	I_H		200		μA	Either direction
ZERO CROSSING						
Inhibit voltage (MT1-MT2 voltage above which device will not trigger)	V_{IH}		25	40	V	$I_F=\text{Rated } I_{FT}$
Leakage in inhibited state						
MCP3030, MCP3031	I_{DRM2}		100	200	μA	$I_F=\text{Rated } I_{FT}$, $V_{DRM}=250\text{ V}$
MCP3040, MCP3041	I_{DRM2}		100	300	μA	$V_{DRM}=400\text{ V}$

ISOLATION CHARACTERISTICS

CHARACTERISTICS	SYMBOL	MIN.	TYP.	MAX.	UNITS	TEST CONDITIONS
Isolation voltage	V_{ISO}	5300			V_{ACRMS}	Relative humidity $\leq 50\%$, $I_{L0} \leq 10\ \mu\text{A}$, 5 seconds
	V_{ISO}	7500			V_{ACPEAK}	Relative humidity $\leq 50\%$, $I_{L0} \leq 10\ \mu\text{A}$, 5 seconds
Isolation resistance	R_{ISO}	10^{11}			ohms	$V_{L0} \leq 500\text{ VDC}$
Isolation capacitance	C_{ISO}		0.5		pF	$f=1\text{ MHz}$

MCP3030* MCP3031 MCP3032 MCP3040/OZ* MCP3041/1Z MCP3042/2Z



VDE APPROVED
ZERO-CROSSING TRIACS



T-41-87

TYPICAL ELECTRICAL CHARACTERISTIC CURVES

($T_A = 25^\circ\text{C}$ Unless Otherwise Specified)

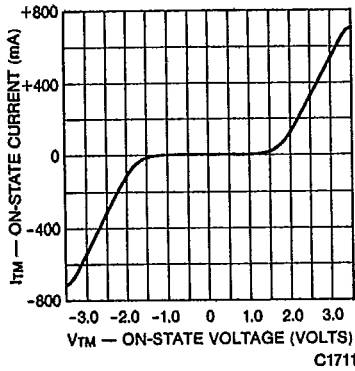

Fig. 1. On-State Characteristics

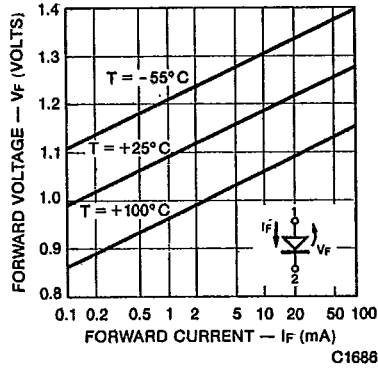

Fig. 2. Forward Voltage vs. Forward Current

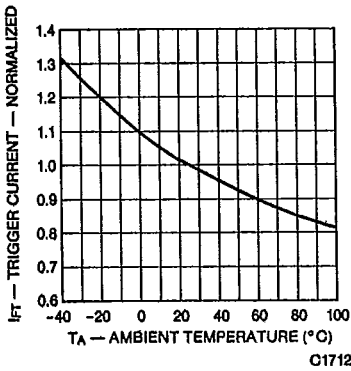

Fig. 3. Trigger Current vs. Temperature

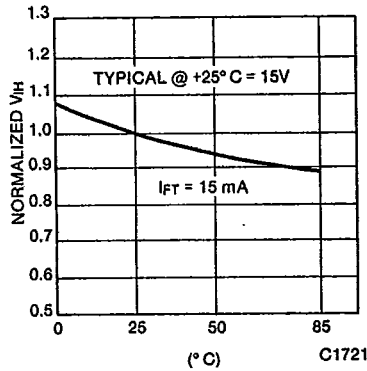

Fig. 4. Normalized Inhibit Voltage vs. Temperature

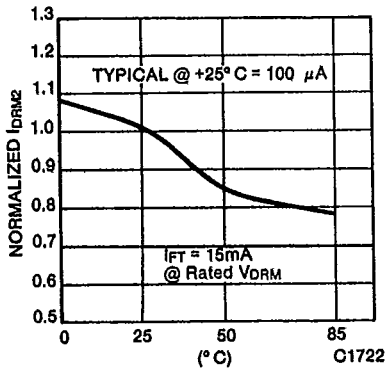

Fig. 5. Normalized I_{DRM2} vs. Temperature

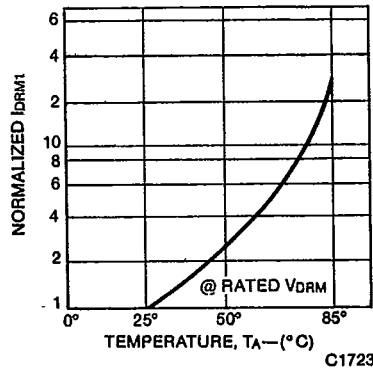

Fig. 6. Normalized I_{DRM1} vs. Temperature

MCP3030* MCP3031 MCP3032 MCP3040/OZ* MCP3041/1Z MCP3042/2Z



**VDE APPROVED
ZERO-CROSSING TRIACS**

T-41-87

APPLICATIONS

Typical TTL Logic → AC Power Interface

I. LED Trigger Current Requirements

DEVICE	V _{CC}	R _F (MAX)	I _{FT}
MCP30X1	5V	160Ω	15mA
MCP30X1	12V	560Ω	15mA
MCP30X0	5V	86Ω	30mA
MCP30X0	12V	290Ω	30mA

II. Device/Line Voltage/Load Selection

DEVICE	V _F (RMS)	LOAD TYPE	SNUBBER REQUIREMENT
MCP303X	≤ 120V	Resistive	No
MCP304X	≤ 240V	Resistive	No
MCP303X	≤ 120V	Inductive	Yes
MCP304X	≤ 240V	Inductive	Yes

III. Typical Circuits @ T_A ≤ 70°C

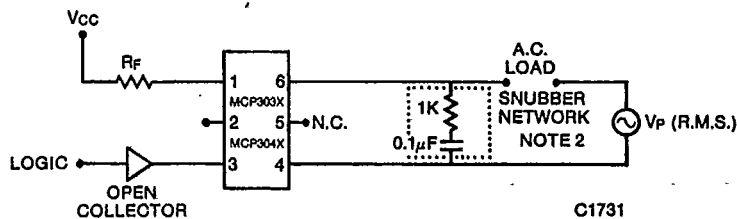

Fig. 7. For Load Circuit I_L < 50mA

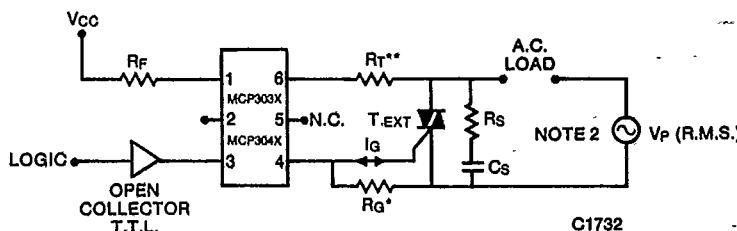

Fig. 8. For Load Circuit I_L > 50mA

* R_G = 1kΩ optional for sensitive gate T_{EXT} - I_G < 10mA
 ** R_T = 180Ω for I_G < 100mA
 R_T = 86Ω for 100 mA < I_G < 200mA

Typical Snubber Values — Fig. 7. Circuit Driving Inductive Load:

TEXT dV / dt (V/μs)	RMS LOAD CURRENT I _L (A)							LEGEND: R _S Ω/C _S (μF)
	100mA	500mA	1A	2A	5A	10A	50A	
1	33k / 0.015	5.6k / 0.068	3.3k / 0.15	1k / 0.22	560 / 0.68	330 / 1.5	56 / 6.8	
2	56k / 0.0033	8.2k / 0.022	5.6k / 0.033	3.3k / 0.068	820 / 0.22	560 / 0.33	86 / 2.20	
5	no snubber	33k / 0.0033	10k / 0.005	6.8k / 0.01	3.3k / 0.02	1k / 0.05	330 / 0.33	
10	no snubber	no snubber	33k / 0.0022	10k / 0.0033	6.8k / 0.0068	3.3k / 0.015	620 / 0.068	

Given:
 1. RMS Load Current
 2. ≤ 240 V (RMS) Line
 3. Commutating dV/dt rating of T_{EXT}

NOTES

- MCP304X and T_{EXT} V_{DRM} ≥ 400 V recommended for 120 V inductive loads - Fig. 7.
- Capacitor working voltage ≥ 2X RMS line voltage (V_P)

MCP3030* MCP3031 MCP3032 MCP3040/OZ* MCP3041/1Z MCP3042/2Z

SURFACE MOUNT OPTIONS

FEATURES

OPTION 100 & 200

- Surface Mount Options available for all Quality Technologies 6 pin and 8 pin dual in-line optocouplers.
- Industry Standard lead co-planarity — within 0.1 mm/.004 inch.
- Compatible with vapor phase reflow soldering — withstands standard 215°C/30 second process.
- Electrical specifications unchanged - see applicable device data sheets.
- Uncompromised isolation performance.
- UL approved - File E50151.

OPTION 100

- Trimmed (butt joint) leads for minimal foot print.
- 0.51 mm/0.02 inch minimum package standoff for board cleaning.

OPTION 200

- Formed leads for JEDEC MS-013 surface mount specification compatibility.

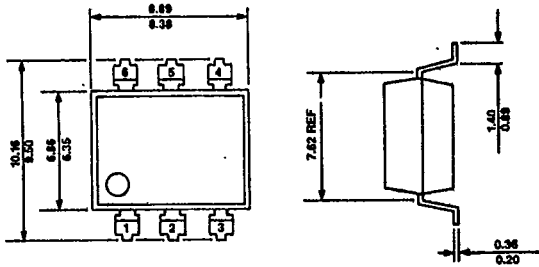

DIMENSIONS IN mm

Option 200 / 6-Pin

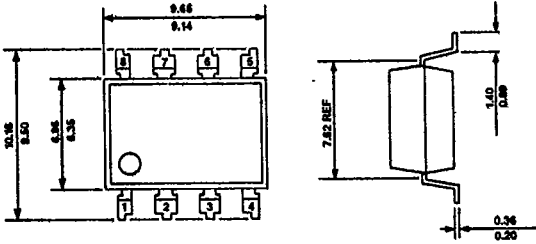
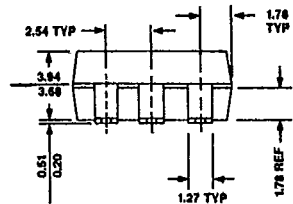

DIMENSIONS IN mm

Option 200 / 8-Pin

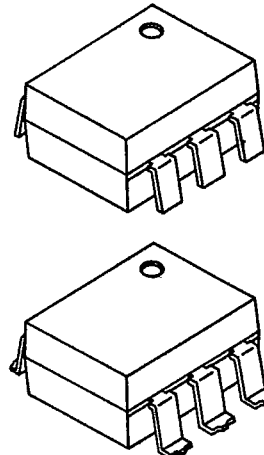
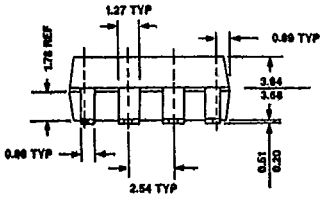

SURFACE MOUNT OPTIONS



SURFACE MOUNT OPTIONS

T-90-2D

SMD OPTION 100

PACKAGE DIMENSIONS

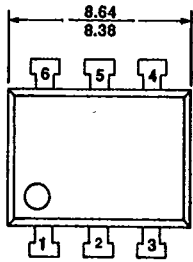

C2074

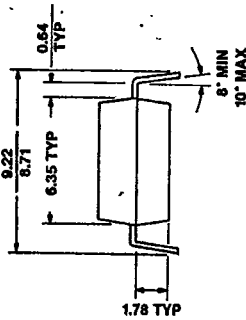

C2075

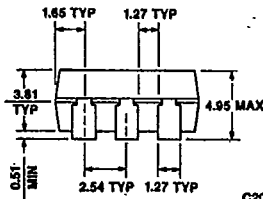

C2076A

6-Pin Optocoupler

DIMENSIONS IN mm

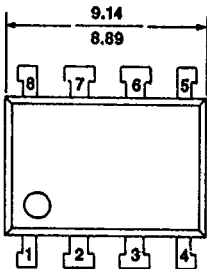

C2077

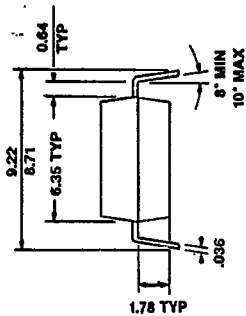

C2075A

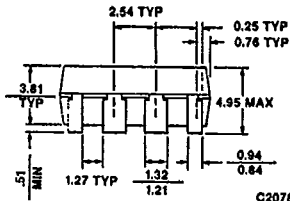

C2078A

8-Pin Optocoupler

DIMENSIONS IN mm

FEATURES

T-90-3D

- Surface mountable
- Lead co-planarity with 0.1 mm or .004 inches
- Compatible with vapor phase reflow soldering
- All 6-pin and 8-pin optocouplers
- All electrical specifications remain unchanged
- Come in standard anti-static shipping tubes

ORDER INFORMATION

Option 100/200 is available for all 6-pin and 8-pin optocouplers in plastic package with certain minimum quantity restrictions.

To order these SMD version of an optocoupler just add -100 to the part number, for example:

74OL6000-100	Optologic
MCT62-100	Dual Transistor Output
HCPL-2631-100	Dual Logic Output
MCT2-100	Single Transistor Output

DESCRIPTION

Option 100 is a standard DIP plastic package optocoupler with the leads cut off at the standoff. This provides a low cost SMD-version of a large variety of optocouplers. Option 100, in many cases, can be tested and handled by the same equipment as a standard DIP package, which eliminates costly duplication of testers and handlers.

The distance from the bottom of the Option 100 to the PCB is a minimum of 0.51 mm or .020 inches, in order to accommodate PCB cleaning after soldering. The height of the Option 100 over the PCB is maximum 4.95 mm or .195 inches.

SPECIFICATIONS

The electrical specifications for optocouplers with Option 100 remain unchanged. See applicable datasheet. In addition, the device will withstand standard vapor phase reflow soldering at 215°C for 30 seconds.

SURFACE MOUNT OPTIONS



T-90-20
 6-PIN SURFACE MOUNT
 T-90-30
TAPE AND REEL

1

PACKAGE DIMENSIONS (OPTION 200)

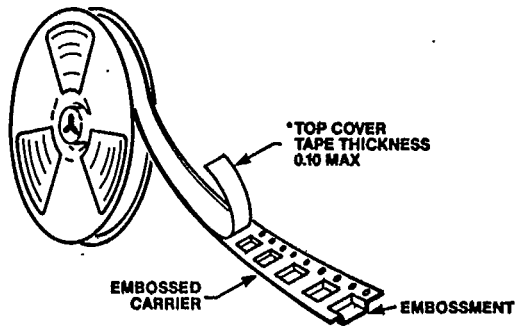
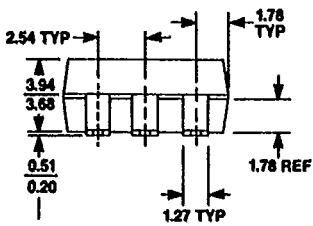
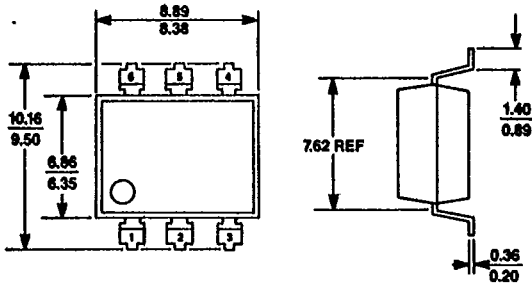

FEATURES

- Taping of Surface-Mount optocouplers for compatibility with automatic placement equipment
- Packaging in full compliance with EIA Standard 481-A—Option 200
- Efficient packaging, static-inhibiting materials, industry compatible tape
- Bar coding label for optimum inventory control
- Option 100 parts do not meet EIA Standard 481-A specifications.

ORDERING INFORMATION

To order 6-pin package on Tape and Reel, include appropriate standard device part number, option, and suffix code to specify Tape and Reel. Standard quantity per reel is 1000 parts.

For example:

MCT2.200 D

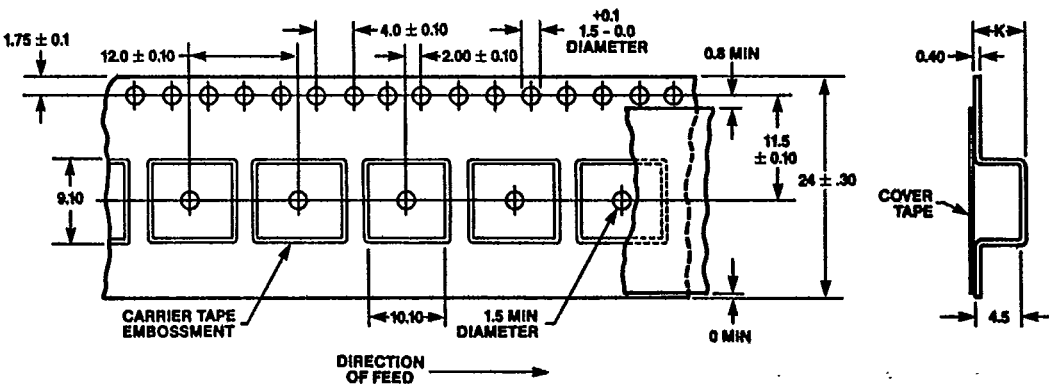
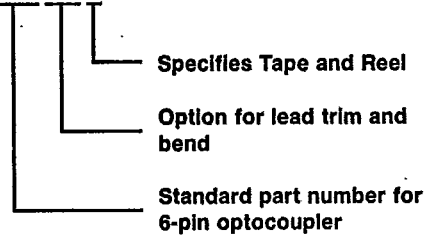

ALL DIMENSIONS IN mm.
 ALL DIMENSIONS AND TOLERANCES PER E.I.A. STANDARD 481-A

TAPE AND REEL



T-90-20
8-PIN SURFACE MOUNT

TAPE AND REEL

PACKAGE DIMENSIONS (OPTION 200)

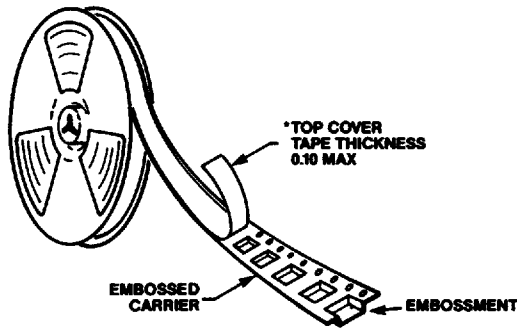
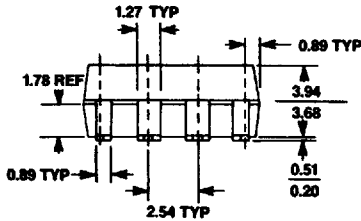
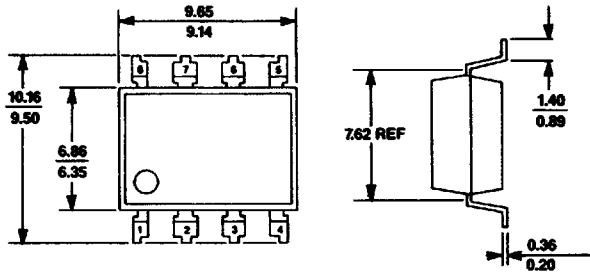

FEATURES

- Taping of Surface-Mount optocouplers for compatibility with automatic placement equipment
- Packaging in full compliance with EIA Standard 481-A—Option 100 and 200
- Efficient packaging, static-inhibiting materials, industry compatible tape
- Bar coding label for optimum inventory control

ORDERING INFORMATION

To order 8-pin package on Tape and Reel, include appropriate standard device part number, option, and suffix code to specify Tape and Reel. Standard quantity per reel is 1000 parts.

For example:

MCT9001.200 D

Specifies Tape and Reel

Option for lead trim and bend

Standard part number for 8-pin optocoupler

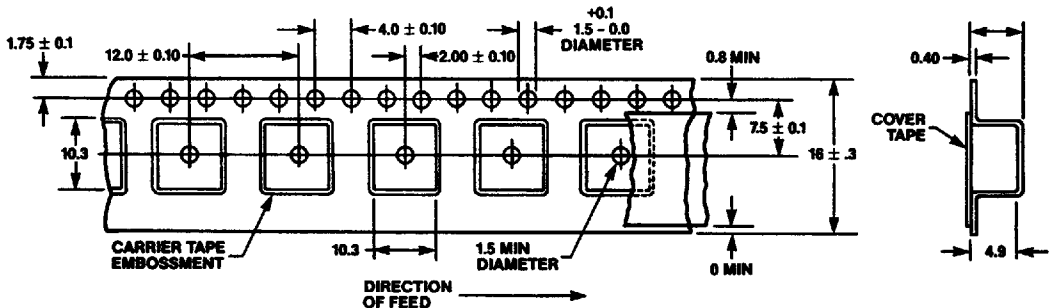

ALL DIMENSIONS ARE IN mm.
ALL DIMENSIONS AND TOLERANCES PER E.I.A. STANDARD 481-A.

TAPE AND REEL