

# SN54LV595A, SN74LV595A 8-BIT SHIFT REGISTERS WITH 3-STATE OUTPUT REGISTERS

SCLS414C – APRIL 1998 – REVISED MARCH 1999

- **EPIC™ (Enhanced-Performance Implanted CMOS) Process**
- **Typical  $V_{OLP}$  (Output Ground Bounce)  $< 0.8$  V at  $V_{CC} = 3.3$  V,  $T_A = 25^\circ\text{C}$**
- **Typical  $V_{OHV}$  (Output  $V_{OH}$  Undershoot)  $> 2$  V at  $V_{CC} = 3.3$  V,  $T_A = 25^\circ\text{C}$**
- **8-Bit Serial-In, Parallel-Out Shift**
- **Shift Register Has Direct Clear**
- **Latch-Up Performance Exceeds 250 mA Per JESD 17**
- **ESD Protection Exceeds 2000 V Per MIL-STD-883, Method 3015; Exceeds 200 V Using Machine Model (C = 200 pF, R = 0)**
- **Package Options Include Plastic Small-Outline (D, NS), Shrink Small-Outline (DB), and Thin Shrink Small-Outline (PW) Packages, Ceramic Flat (W) Packages, Chip Carriers (FK), and DIPs (J)**

## description

The 'LV595A devices are 8-bit shift registers designed for 2-V to 5.5-V  $V_{CC}$  operation.

These devices contain an 8-bit serial-in, parallel-out shift register that feeds an 8-bit D-type storage register. The storage register has parallel 3-state outputs. Separate clocks are provided for both the shift and storage register. The shift register has a direct overriding clear ( $\overline{SRCLR}$ ) input, serial (SER) input, and a serial output for cascading. When the output-enable ( $\overline{OE}$ ) input is high, all outputs except  $Q_H$  are in the high-impedance state.

Both the shift register clock (SRCLK) and storage register clock (RCLK) are positive-edge triggered. If both clocks are connected together, the shift register is always one clock pulse ahead of the storage register.

To ensure the high-impedance state during power up or power down,  $\overline{OE}$  should be tied to  $V_{CC}$  through a pullup resistor; the minimum value of the resistor is determined by the current-sinking capability of the driver.

The SN54LV595A is characterized for operation over the full military temperature range of  $-55^\circ\text{C}$  to  $125^\circ\text{C}$ . The SN74LV595A is characterized for operation from  $-40^\circ\text{C}$  to  $85^\circ\text{C}$ .

SN54LV595A . . . J OR W PACKAGE  
SN74LV595A . . . D, DB, NS, OR PW PACKAGE  
(TOP VIEW)

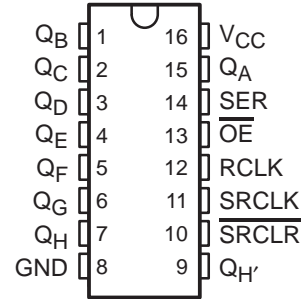

SN54LV595A . . . FK PACKAGE  
(TOP VIEW)

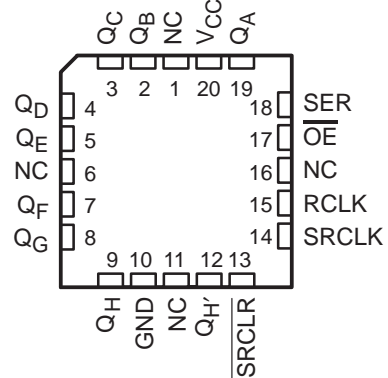

NC – No internal connection



Please be aware that an important notice concerning availability, standard warranty, and use in critical applications of Texas Instruments semiconductor products and disclaimers thereto appears at the end of this data sheet.

EPIC is a trademark of Texas Instruments Incorporated.

UNLESS OTHERWISE NOTED this document contains PRODUCTION DATA information current as of publication date. Products conform to specifications per the terms of Texas Instruments standard warranty. Production processing does not necessarily include testing of all parameters.



POST OFFICE BOX 655303 • DALLAS, TEXAS 75265

Copyright © 1999, Texas Instruments Incorporated

**SN54LV595A, SN74LV595A**  
**8-BIT SHIFT REGISTERS**  
**WITH 3-STATE OUTPUT REGISTERS**  
 SCLS414C – APRIL 1998 – REVISED MARCH 1999

**logic symbol†**

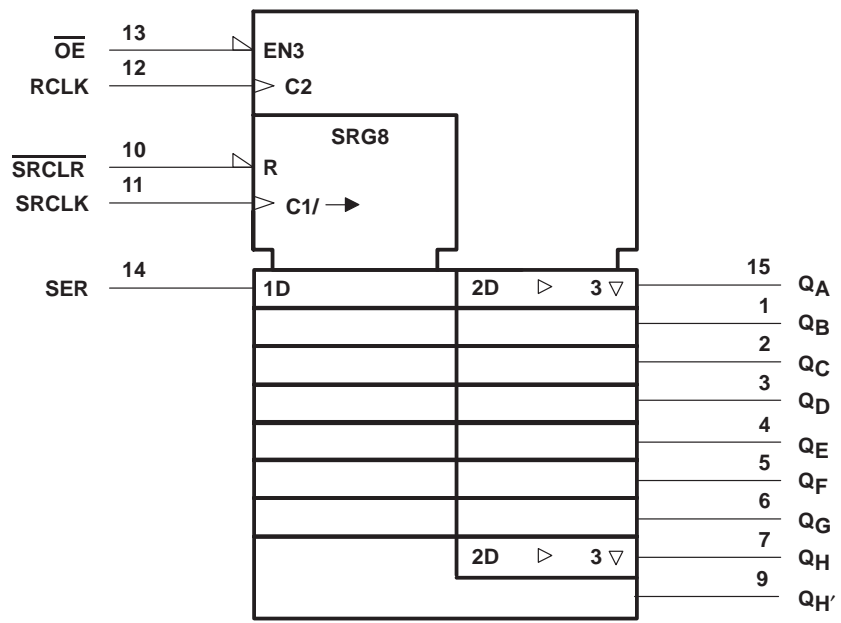

† This symbol is in accordance with ANSI/IEEE Std 91-1984 and IEC Publication 617-12. Pin numbers shown are for the D, DB, J, NS, PW, and W packages.

**SN54LV595A, SN74LV595A**  
**8-BIT SHIFT REGISTERS**  
**WITH 3-STATE OUTPUT REGISTERS**  
SCLS414C – APRIL 1998 – REVISED MARCH 1999

logic diagram (positive logic)

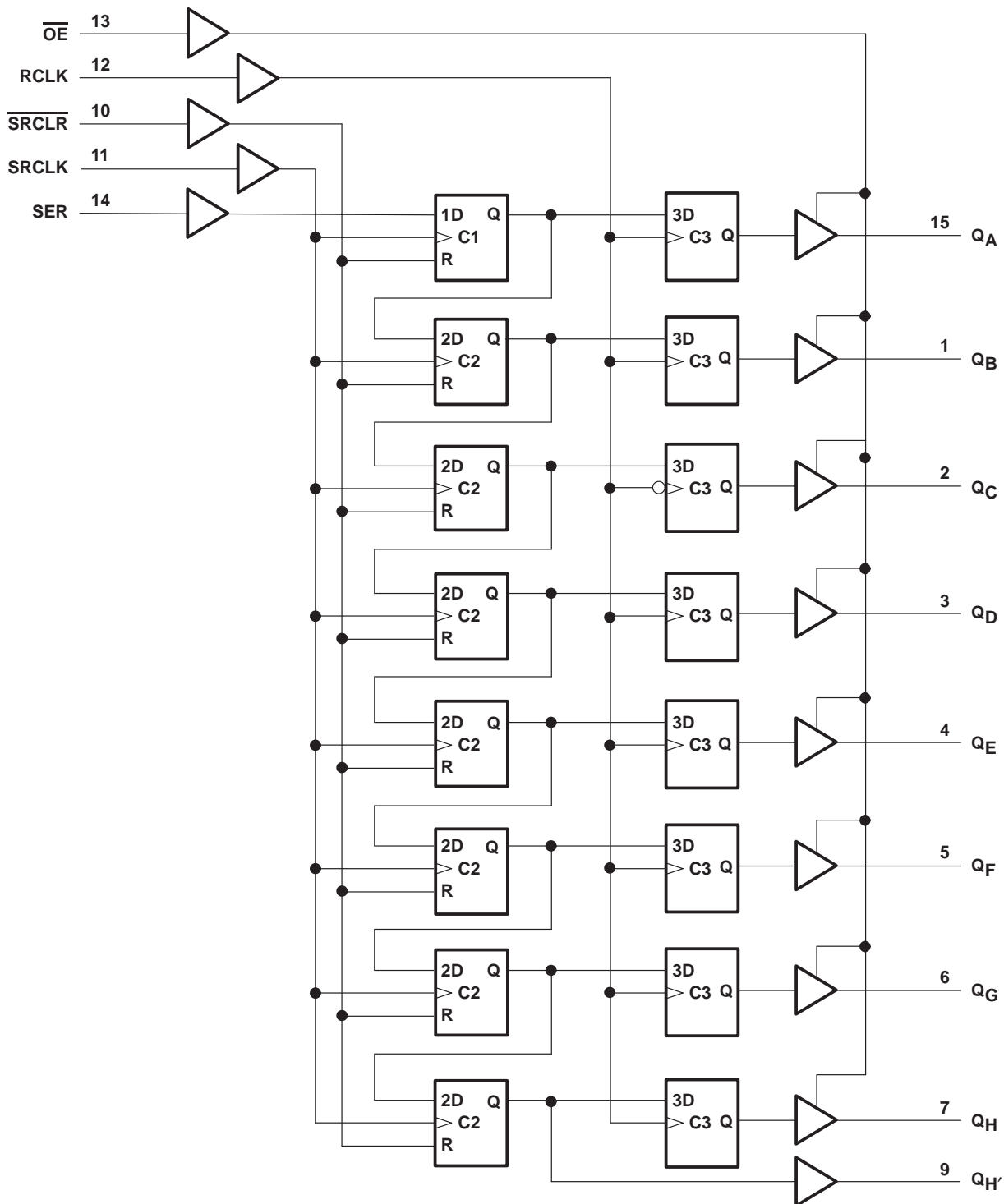

Pin numbers shown are for the D, DB, J, NS, PW, and W packages.

**SN54LV595A, SN74LV595A**  
**8-BIT SHIFT REGISTERS**  
**WITH 3-STATE OUTPUT REGISTERS**

SCLS414C – APRIL 1998 – REVISED MARCH 1999

**absolute maximum ratings over operating free-air temperature range (unless otherwise noted)†**

Supply voltage range, $V_{CC}$ .....	-0.5 V to 7 V
Input voltage range, $V_I$ (see Note 1) .....	-0.5 V to 7 V
Output voltage range applied in the high or low state, $V_O$ (see Notes 1 and 2) .....	-0.5 V to $V_{CC} + 0.5$ V
Output voltage range applied in high-impedance or power-off state, $V_O$ (see Note 1) .....	-0.5 V to 7 V
Input clamp current, $I_{IK}$ ( $V_I < 0$ ) .....	-20 mA
Output clamp current, $I_{OK}$ ( $V_O < 0$ or $V_O > V_{CC}$ ) .....	$\pm 50$ mA
Continuous output current, $I_O$ ( $V_O = 0$ to $V_{CC}$ ) .....	$\pm 35$ mA
Continuous current through $V_{CC}$ or GND .....	$\pm 70$ mA
Package thermal impedance, $\theta_{JA}$ (see Note 3): D package .....	113°C/W
DB package .....	131°C/W
NS package .....	111°C/W
PW package .....	149°C/W
Storage temperature range, $T_{stg}$ .....	-65°C to 150°C

† Stresses beyond those listed under “absolute maximum ratings” may cause permanent damage to the device. These are stress ratings only, and functional operation of the device at these or any other conditions beyond those indicated under “recommended operating conditions” is not implied. Exposure to absolute-maximum-rated conditions for extended periods may affect device reliability.

- NOTES: 1. The input and output voltage ratings may be exceeded if the input and output current ratings are observed.  
 2. This value is limited to 7 V maximum.  
 3. The package thermal impedance is calculated in accordance with JESD 51.



**SN54LV595A, SN74LV595A**  
**8-BIT SHIFT REGISTERS**  
**WITH 3-STATE OUTPUT REGISTERS**  
 SCLS414C – APRIL 1998 – REVISED MARCH 1999

**recommended operating conditions (see Note 4)**

		SN54LV595A		SN74LV595A		UNIT	
		MIN	MAX	MIN	MAX		
V <sub>CC</sub>	Supply voltage	2	5.5	2	5.5	V	
V <sub>IH</sub>	High-level input voltage	V <sub>CC</sub> = 2 V	1.5	1.5		V	
		V <sub>CC</sub> = 2.3 V to 2.7 V	V <sub>CC</sub> × 0.7	V <sub>CC</sub> × 0.7			
		V <sub>CC</sub> = 3 V to 3.6 V	V <sub>CC</sub> × 0.7	V <sub>CC</sub> × 0.7			
		V <sub>CC</sub> = 4.5 V to 5.5 V	V <sub>CC</sub> × 0.7	V <sub>CC</sub> × 0.7			
V <sub>IL</sub>	Low-level input voltage	V <sub>CC</sub> = 2 V	0.5	0.5		V	
		V <sub>CC</sub> = 2.3 V to 2.7 V	V <sub>CC</sub> × 0.3	V <sub>CC</sub> × 0.3			
		V <sub>CC</sub> = 3 V to 3.6 V	V <sub>CC</sub> × 0.3	V <sub>CC</sub> × 0.3			
		V <sub>CC</sub> = 4.5 V to 5.5 V	V <sub>CC</sub> × 0.3	V <sub>CC</sub> × 0.3			
V <sub>I</sub>	Input voltage	0	5.5	0	5.5	V	
V <sub>O</sub>	Output voltage	High or low state	0	V <sub>CC</sub>	0	V <sub>CC</sub>	V
		3-state	0	5.5	0	5.5	
I <sub>OH</sub>	High-level output current	V <sub>CC</sub> = 2 V		-50	-50	μA	
		V <sub>CC</sub> = 2.3 V to 2.7 V		-2	-2		
		V <sub>CC</sub> = 3 V to 3.6 V		-8	-8	mA	
		V <sub>CC</sub> = 4.5 V to 5.5 V		-16	-16		
I <sub>OL</sub>	Low-level output current	V <sub>CC</sub> = 2 V		50	50	μA	
		V <sub>CC</sub> = 2.3 V to 2.7 V		2	2		
		V <sub>CC</sub> = 3 V to 3.6 V		8	8	mA	
		V <sub>CC</sub> = 4.5 V to 5.5 V		16	16		
Δt/Δv	Input transition rise or fall rate	V <sub>CC</sub> = 2.3 V to 2.7 V	0	200	0	200	ns/V
		V <sub>CC</sub> = 3 V to 3.6 V	0	100	0	100	
		V <sub>CC</sub> = 4.5 V to 5.5 V	0	20	0	20	
T <sub>A</sub>	Operating free-air temperature	-55	125	-40	85	°C	

NOTE 4: All unused inputs of the device must be held at V<sub>CC</sub> or GND to ensure proper device operation. Refer to the TI application report, *Implications of Slow or Floating CMOS Inputs*, literature number SCBA004.

# SN54LV595A, SN74LV595A 8-BIT SHIFT REGISTERS WITH 3-STATE OUTPUT REGISTERS

SCLS414C – APRIL 1998 – REVISED MARCH 1999

electrical characteristics over recommended operating free-air temperature range (unless otherwise noted)

PARAMETER	TEST CONDITIONS	V <sub>CC</sub>	SN54LV595A			SN74LV595A			UNIT
			MIN	TYP	MAX	MIN	TYP	MAX	
V <sub>OH</sub>	I <sub>OH</sub> = -50 μA	2 V to 5.5 V	V <sub>CC</sub> -0.1			V <sub>CC</sub> -0.1			V
		2.3 V	2			2			
	Q <sub>H</sub> '	3 V	2.48			2.48			
			2.48			2.48			
	Q <sub>A</sub> -Q <sub>H</sub>	4.5 V	3.8			3.8			
			3.8			3.8			
V <sub>OL</sub>	I <sub>OL</sub> = 50 μA	2 V to 5.5 V	0.1			0.1			V
		2.3 V	0.4			0.4			
	Q <sub>H</sub> '	3 V	0.44			0.44			
			0.44			0.44			
	Q <sub>A</sub> -Q <sub>H</sub>	4.5 V	0.55			0.55			
			0.55			0.55			
I <sub>I</sub>	V <sub>I</sub> = V <sub>CC</sub> or GND	5.5 V	±1			±1			μA
I <sub>OZ</sub>	V <sub>O</sub> = V <sub>CC</sub> or GND	5.5 V	±5			±5			μA
I <sub>CC</sub>	V <sub>I</sub> = V <sub>CC</sub> or GND    I <sub>O</sub> = 0	5.5 V	20			20			μA
I <sub>off</sub>	V <sub>I</sub> or V <sub>O</sub> = 0 to 5.5 V	0 V	5			5			μA
C <sub>i</sub>	V <sub>I</sub> = V <sub>CC</sub> or GND	3.3 V	3.5			3.5			pF
		5 V	3			3			

timing requirements over recommended operating free-air temperature range, V<sub>CC</sub> = 2.5 V ± 0.2 V (unless otherwise noted) (see Figure 1)

		T <sub>A</sub> = 25°C		SN54LV595A		SN74LV595A		UNIT
		MIN	MAX	MIN	MAX	MIN	MAX	
t <sub>w</sub>	Pulse duration	SRCLK high or low		7		7.5		ns
		RCLK high or low		7		7.5		
		SRCLR low		6		6.5		
t <sub>su</sub>	Setup time	SER before SRCLK↑		2.5		3		ns
		SRCLK↑ before RCLK↑†		8		9		
		SRCLR low before RCLK↑		8.5		9.5		
		SRCLR high (inactive) before SRCLK↑		4		4		
t <sub>h</sub>	Hold time	SER after SRCLK↑		1.5		1.5		ns

† This setup time allows the storage register to receive stable data from the shift register. The clocks can be tied together, in which case the shift register is one clock pulse ahead of the storage register.

PRODUCT PREVIEW information concerns products in the formative or design phase of development. Characteristic data and other specifications are design goals. Texas Instruments reserves the right to change or discontinue these products without notice.



POST OFFICE BOX 655303 • DALLAS, TEXAS 75265

**SN54LV595A, SN74LV595A**  
**8-BIT SHIFT REGISTERS**  
**WITH 3-STATE OUTPUT REGISTERS**  
 SCLS414C – APRIL 1998 – REVISED MARCH 1999

**timing requirements over recommended operating free-air temperature range,  $V_{CC} = 3.3\text{ V} \pm 0.3\text{ V}$  (unless otherwise noted) (see Figure 1)**

		$T_A = 25^\circ\text{C}$		SN54LV595A		SN74LV595A		UNIT
		MIN	MAX	MIN	MAX	MIN	MAX	
$t_w$	Pulse duration	SRCLK high or low		5.5	5.5	5.5	5.5	ns
		RCLK high or low		5.5	5.5	5.5	5.5	
		SRCLR low		5	5	5	5	
$t_{su}$	Setup time	SER before SRCLK $\uparrow$		3.5	3.5	3.5	3.5	ns
		SRCLK $\uparrow$ before RCLK $\uparrow$ $\dagger$		8	8.5	8.5	8.5	
		SRCLR low before RCLK $\uparrow$		8	9	9	9	
		SRCLR high (inactive) before SRCLK $\uparrow$		3	3	3	3	
$t_h$	Hold time	SER after SRCLK $\uparrow$		1.5	1.5	1.5	1.5	ns

$\dagger$  This setup time allows the storage register to receive stable data from the shift register. The clocks can be tied together, in which case the shift register is one clock pulse ahead of the storage register.

**timing requirements over recommended operating free-air temperature range,  $V_{CC} = 5\text{ V} \pm 0.5\text{ V}$  (unless otherwise noted) (see Figure 1)**

		$T_A = 25^\circ\text{C}$		SN54LV595A		SN74LV595A		UNIT
		MIN	MAX	MIN	MAX	MIN	MAX	
$t_w$	Pulse duration	SRCLK high or low		5	5	5	5	ns
		RCLK high or low		5	5	5	5	
		SRCLR low		5.2	5.2	5.2	5.2	
$t_{su}$	Setup time	SER before SRCLK $\uparrow$		3	3	3	3	ns
		SRCLK $\uparrow$ before RCLK $\uparrow$ $\dagger$		5	5	5	5	
		SRCLR low before RCLK $\uparrow$		5	5	5	5	
		SRCLR high (inactive) before SRCLK $\uparrow$		2.5	2.5	2.5	2.5	
$t_h$	Hold time	SER after SRCLK $\uparrow$		2	2	2	2	ns

$\dagger$  This setup time allows the storage register to receive stable data from the shift register. The clocks can be tied together, in which case the shift register is one clock pulse ahead of the storage register.

**SN54LV595A, SN74LV595A**  
**8-BIT SHIFT REGISTERS**  
**WITH 3-STATE OUTPUT REGISTERS**

SCLS414C – APRIL 1998 – REVISED MARCH 1999

switching characteristics over recommended operating free-air temperature range,  
 $V_{CC} = 2.5 V \pm 0.2 V$  (unless otherwise noted) (see Figure 1)

PARAMETER	FROM (INPUT)	TO (OUTPUT)	LOAD CAPACITANCE	$T_A = 25^\circ C$			SN54LV595A		SN74LV595A		UNIT
				MIN	TYP	MAX	MIN	MAX	MIN	MAX	
$f_{max}$			$C_L = 15 pF^*$	65	80		45		45		MHz
			$C_L = 50 pF$	60	70		40		40		
$t_{PLH}^*$	RCLK	$Q_A-Q_H$	$C_L = 15 pF$		8.4	14.2	1	15.8	1	15.8	ns
$t_{PHL}^*$					8.4	14.2	1	15.8	1	15.8	
$t_{PLH}^*$	SRCLK	$Q_H$			9.4	19.6	1	22.2	1	22.2	
$t_{PHL}^*$					9.4	19.6	1	22.2	1	22.2	
$t_{PHL}^*$	$\overline{SRCLR}$	$Q_H$			8.7	14.6	1	16.3	1	16.3	
$t_{PZH}^*$	$\overline{OE}$	$Q_A-Q_H$			8.2	13.9	1	15	1	15	
$t_{PZL}^*$					10.9	18.1	1	20.3	1	20.3	
$t_{PHZ}^*$	$\overline{OE}$	$Q_A-Q_H$			8.3	13.7	1	15.6	1	15.6	
$t_{PLZ}^*$					9.2	15.2	1	16.7	1	16.7	
$t_{PLH}$	RCLK	$Q_A-Q_H$		$C_L = 50 pF$		11.2	17.2	1	19.3	1	
$t_{PHL}$					11.2	17.2	1	19.3	1	19.3	
$t_{PLH}$	SRCLK	$Q_H$			13.1	22.5	1	25.5	1	25.5	
$t_{PHL}$					13.1	22.5	1	25.5	1	25.5	
$t_{PHL}$	$\overline{SRCLR}$	$Q_H$			12.4	18.8	1	21.1	1	21.1	
$t_{PZH}$	$\overline{OE}$	$Q_A-Q_H$			10.8	17	1	18.3	1	18.3	
$t_{PZL}$					13.4	21	1	23	1	23	
$t_{PHZ}$	$\overline{OE}$	$Q_A-Q_H$			12.2	18.3	1	19.5	1	19.5	
$t_{PLZ}$					14	20.9	1	22.6	1	22.6	

\* On products compliant to MIL-PRF-38535, this parameter is not production tested.

**SN54LV595A, SN74LV595A**  
**8-BIT SHIFT REGISTERS**  
**WITH 3-STATE OUTPUT REGISTERS**  
 SCLS414C – APRIL 1998 – REVISED MARCH 1999

switching characteristics over recommended operating free-air temperature range,  
 $V_{CC} = 3.3\text{ V} \pm 0.3\text{ V}$  (unless otherwise noted) (see Figure 1)

PARAMETER	FROM (INPUT)	TO (OUTPUT)	LOAD CAPACITANCE	$T_A = 25^\circ\text{C}$			SN54LV595A		SN74LV595A		UNIT
				MIN	TYP	MAX	MIN	MAX	MIN	MAX	
$f_{\text{max}}$			$C_L = 15\text{ pF}^*$	80	120		70		70		MHz
			$C_L = 50\text{ pF}$	55	105		50		50		
$t_{\text{PLH}}^*$	RCLK	$Q_A-Q_H$	$C_L = 15\text{ pF}$	6	11.9		1	13.5	1	13.5	ns
$t_{\text{PHL}}^*$				6	11.9		1	13.5	1	13.5	
$t_{\text{PLH}}^*$	SRCLK	$Q_{H'}$		6.6	13		1	15	1	15	
$t_{\text{PHL}}^*$				6.6	13		1	15	1	15	
$t_{\text{PHL}}^*$	$\overline{\text{SRCLR}}$	$Q_{H'}$		6.2	12.8		1	13.7	1	13.7	
$t_{\text{PZH}}^*$	$\overline{\text{OE}}$	$Q_A-Q_H$		6	11.5		1	13.5	1	13.5	
$t_{\text{PZL}}^*$				7.8	11.5		1	13.5	1	13.5	
$t_{\text{PHZ}}^*$	$\overline{\text{OE}}$	$Q_A-Q_H$		6.1	14.7		1	15.2	1	15.2	
$t_{\text{PLZ}}^*$				6.3	14.7		1	15.2	1	15.2	
$t_{\text{PLH}}$	RCLK	$Q_A-Q_H$		$C_L = 50\text{ pF}$	7.9	15.4		1	17	1	
$t_{\text{PHL}}$			7.9		15.4		1	17	1	17	
$t_{\text{PLH}}$	SRCLK	$Q_{H'}$	9.2		16.5		1	18.5	1	18.5	
$t_{\text{PHL}}$			9.2		16.5		1	18.5	1	18.5	
$t_{\text{PHL}}$	$\overline{\text{SRCLR}}$	$Q_{H'}$	9		16.3		1	17.2	1	17.2	
$t_{\text{PZH}}$	$\overline{\text{OE}}$	$Q_A-Q_H$	7.8		15		1	17	1	17	
$t_{\text{PZL}}$			9.6		15		1	17	1	17	
$t_{\text{PHZ}}$	$\overline{\text{OE}}$	$Q_A-Q_H$	8.1		15.7		1	16.2	1	16.2	
$t_{\text{PLZ}}$			9.3		15.7		1	16.2	1	16.2	

\* On products compliant to MIL-PRF-38535, this parameter is not production tested.

# SN54LV595A, SN74LV595A 8-BIT SHIFT REGISTERS WITH 3-STATE OUTPUT REGISTERS

SCLS414C – APRIL 1998 – REVISED MARCH 1999

switching characteristics over recommended operating free-air temperature range,  
 $V_{CC} = 5\text{ V} \pm 0.5\text{ V}$  (unless otherwise noted) (see Figure 1)

PARAMETER	FROM (INPUT)	TO (OUTPUT)	LOAD CAPACITANCE	$T_A = 25^\circ\text{C}$			SN54LV595A		SN74LV595A		UNIT
				MIN	TYP	MAX	MIN	MAX	MIN	MAX	
$f_{\text{max}}$			$C_L = 15\text{ pF}^*$	135	170		115		115		MHz
			$C_L = 50\text{ pF}$	120	140		95		95		
$t_{\text{PLH}}^*$	RCLK	$Q_A-Q_H$	$C_L = 15\text{ pF}$	4.3	7.4		1	8.5	1	8.5	ns
$t_{\text{PHL}}^*$				4.3	7.4		1	8.5	1	8.5	
$t_{\text{PLH}}^*$	SRCLK	$Q_H$		4.5	8.2		1	9.4	1	9.4	
$t_{\text{PHL}}^*$				4.5	8.2		1	9.4	1	9.4	
$t_{\text{PHL}}^*$	$\overline{\text{SRCLR}}$	$Q_H$		4.5	8		1	9.1	1	9.1	
$t_{\text{PZH}}^*$	$\overline{\text{OE}}$	$Q_A-Q_H$		4.3	8.6		1	10	1	10	
$t_{\text{PZL}}^*$				5.4	8.6		1	10	1	10	
$t_{\text{PHZ}}^*$	$\overline{\text{OE}}$	$Q_A-Q_H$		2.4	6		1	7.1	1	7.1	
$t_{\text{PLZ}}^*$				2.7	5.1			7.2	1	7.2	
$t_{\text{PLH}}$	RCLK	$Q_A-Q_H$		$C_L = 50\text{ pF}$	5.6	9.4		1	10.5	1	
$t_{\text{PHL}}$			5.6		9.4		1	10.5	1	10.5	
$t_{\text{PLH}}$	SRCLK	$Q_H$	6.4		10.2		1	11.4	1	11.4	
$t_{\text{PHL}}$			6.4		10.2		1	11.4	1	11.4	
$t_{\text{PHL}}$	$\overline{\text{SRCLR}}$	$Q_H$	6.4		10		1	11.1	1	11.1	
$t_{\text{PZH}}$	$\overline{\text{OE}}$	$Q_A-Q_H$	5.7		10.6		1	12	1	12	
$t_{\text{PZL}}$			6.8		10.6		1	12	1	12	
$t_{\text{PHZ}}$	$\overline{\text{OE}}$	$Q_A-Q_H$	3.5		10.3		1	11	1	11	
$t_{\text{PLZ}}$			3.4		10.3		1	11	1	11	

\* On products compliant to MIL-PRF-38535, this parameter is not production tested.

noise characteristics,  $V_{CC} = 3.3\text{ V}$ ,  $C_L = 50\text{ pF}$ ,  $T_A = 25^\circ\text{C}$  (see Note 5)

PARAMETER		SN74LV595A			UNIT
		MIN	TYP	MAX	
$V_{OL(P)}$	Quiet output, maximum dynamic $V_{OL}$		0.2		V
$V_{OL(V)}$	Quiet output, minimum dynamic $V_{OL}$		-0.2		V
$V_{OH(V)}$	Quiet output, minimum dynamic $V_{OH}$		3.2		V
$V_{IH(D)}$	High-level dynamic input voltage	2.31			V
$V_{IL(D)}$	Low-level dynamic input voltage			0.99	V

NOTE 5: Characteristics are for surface-mount packages only.

operating characteristics,  $T_A = 25^\circ\text{C}$

PARAMETER		TEST CONDITIONS	$V_{CC}$	TYP	UNIT
$C_{pd}$	Power dissipation capacitance	$C_L = 50\text{ pF}$ , $f = 10\text{ MHz}$	3.3 V	32.7	pF
			5 V	33.1	

PRODUCT PREVIEW information concerns products in the formative or design phase of development. Characteristic data and other specifications are design goals. Texas Instruments reserves the right to change or discontinue these products without notice.



POST OFFICE BOX 655303 • DALLAS, TEXAS 75265

PARAMETER MEASUREMENT INFORMATION

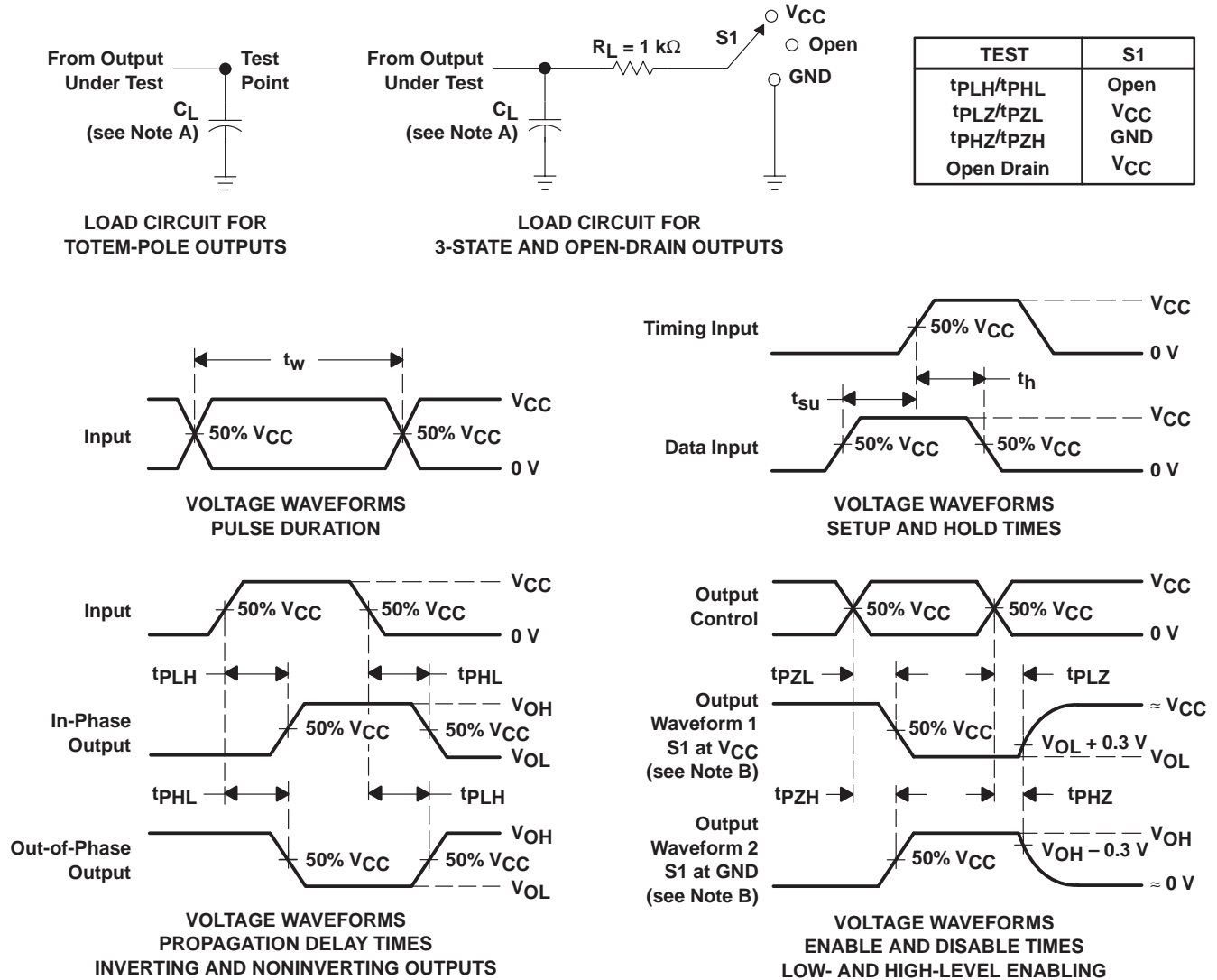

- NOTES: A.  $C_L$  includes probe and jig capacitance.  
 B. Waveform 1 is for an output with internal conditions such that the output is low except when disabled by the output control. Waveform 2 is for an output with internal conditions such that the output is high except when disabled by the output control.  
 C. All input pulses are supplied by generators having the following characteristics: PRR  $\leq 1\text{ MHz}$ ,  $Z_O = 50\ \Omega$ ,  $t_r \leq 3\text{ ns}$ ,  $t_f \leq 3\text{ ns}$ .  
 D. The outputs are measured one at a time with one input transition per measurement.  
 E.  $t_{PLZ}$  and  $t_{PHZ}$  are the same as  $t_{dis}$ .  
 F.  $t_{PZL}$  and  $t_{PZH}$  are the same as  $t_{en}$ .  
 G.  $t_{PHL}$  and  $t_{PLH}$  are the same as  $t_{pd}$ .

Figure 1. Load Circuit and Voltage Waveforms

## IMPORTANT NOTICE

Texas Instruments and its subsidiaries (TI) reserve the right to make changes to their products or to discontinue any product or service without notice, and advise customers to obtain the latest version of relevant information to verify, before placing orders, that information being relied on is current and complete. All products are sold subject to the terms and conditions of sale supplied at the time of order acknowledgement, including those pertaining to warranty, patent infringement, and limitation of liability.

TI warrants performance of its semiconductor products to the specifications applicable at the time of sale in accordance with TI's standard warranty. Testing and other quality control techniques are utilized to the extent TI deems necessary to support this warranty. Specific testing of all parameters of each device is not necessarily performed, except those mandated by government requirements.

CERTAIN APPLICATIONS USING SEMICONDUCTOR PRODUCTS MAY INVOLVE POTENTIAL RISKS OF DEATH, PERSONAL INJURY, OR SEVERE PROPERTY OR ENVIRONMENTAL DAMAGE ("CRITICAL APPLICATIONS"). TI SEMICONDUCTOR PRODUCTS ARE NOT DESIGNED, AUTHORIZED, OR WARRANTED TO BE SUITABLE FOR USE IN LIFE-SUPPORT DEVICES OR SYSTEMS OR OTHER CRITICAL APPLICATIONS. INCLUSION OF TI PRODUCTS IN SUCH APPLICATIONS IS UNDERSTOOD TO BE FULLY AT THE CUSTOMER'S RISK.

In order to minimize risks associated with the customer's applications, adequate design and operating safeguards must be provided by the customer to minimize inherent or procedural hazards.

TI assumes no liability for applications assistance or customer product design. TI does not warrant or represent that any license, either express or implied, is granted under any patent right, copyright, mask work right, or other intellectual property right of TI covering or relating to any combination, machine, or process in which such semiconductor products or services might be or are used. TI's publication of information regarding any third party's products or services does not constitute TI's approval, warranty or endorsement thereof.