

# 1 W BTL mono audio amplifier with DC volume control

TDA7052A/AT

## FEATURES

- DC volume control
- Few external components
- Mute mode
- Thermal protection
- Short-circuit proof
- No switch-on and off clicks
- Good overall stability
- Low power consumption
- Low HF radiation
- ESD protected on all pins

## GENERAL DESCRIPTION

The TDA7052A/AT are mono BTL output amplifiers with DC volume control. They are designed for use in TV and monitors, but also suitable for battery-fed portable recorders and radios.

### Missing Current Limiter (MCL)

A MCL protection circuit is built-in. The MCL circuit is activated when the difference in current between the output terminal of each amplifier exceeds 100 mA (typical 300 mA). This level of 100 mA allows for headphone applications (single-ended).

## QUICK REFERENCE DATA

SYMBOL	PARAMETERS	CONDITIONS	MIN.	TYP.	MAX.	UNIT
$V_P$	positive supply voltage range		4.5	–	18	V
$P_O$	output power					
	TDA7052A	$R_L = 8 \Omega; V_P = 6 V$	1.0	1.1	–	W
	TDA7052AT	$R_L = 16 \Omega; V_P = 6 V$	0.5	0.55	–	W
$G_v$	maximum total voltage gain		34.5	35.5	36.5	dB
$\phi$	gain control range		75	80	–	dB
$I_P$	total quiescent current	$V_P = 6 V; R_L = \infty$	–	7	12	mA
THD	total harmonic distortion					
	TDA7052A	$P_O = 0.5 W$	–	0.3	1	%
	TDA7052AT	$P_O = 0.25 W$	–	0.3	1	%

## ORDERING INFORMATION

EXTENDED TYPE NUMBER	PACKAGE			
	PINS	PIN POSITION	MATERIAL	CODE
TDA7052A	8	DIL	plastic	SOT97 <sup>(1)</sup>
TDA7052AT	8	mini-pack	plastic	SOT96A <sup>(2)</sup>

### Notes

1. SOT97-1; 1996 September 10.
2. SOT96-1; 1996 September 10.

1 W BTL mono audio amplifier with DC volume control

TDA7052A/AT

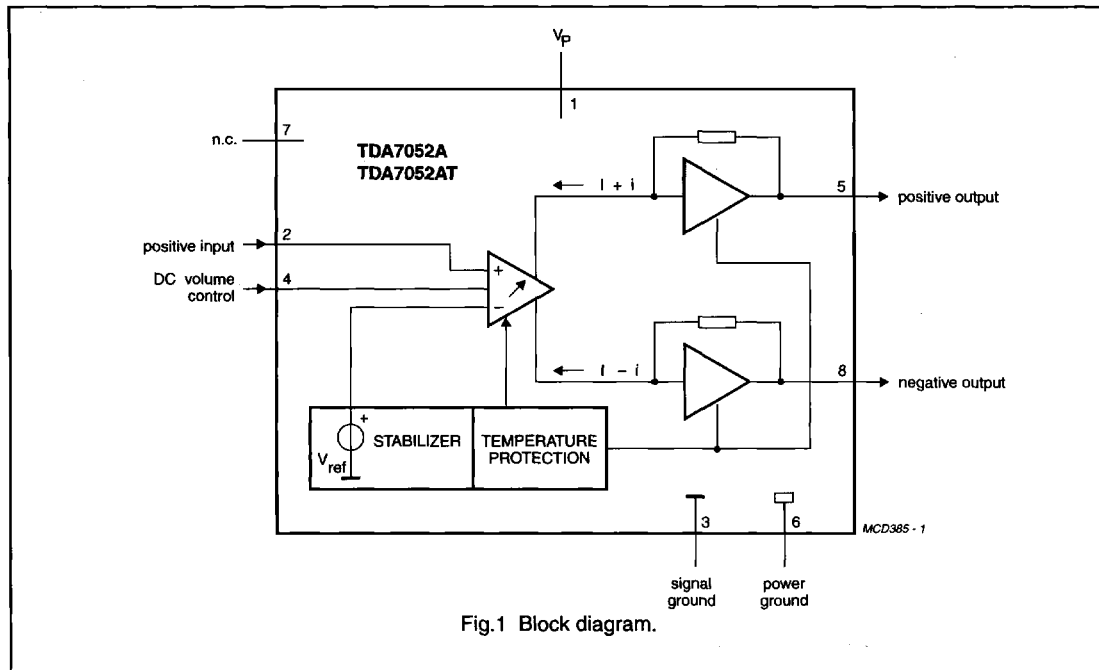

PINNING

SYMBOL	PIN	DESCRIPTION
V <sub>P</sub>	1	positive supply voltage
IN+	2	positive input
GND1	3	signal ground
VC	4	DC volume control
OUT+	5	positive output
GND2	6	power ground
n.c	7	not connected
OUT-	8	negative output

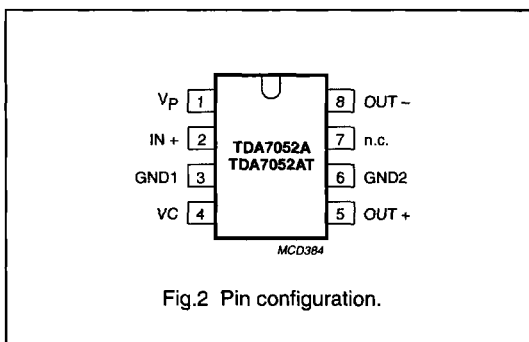

# 1 W BTL mono audio amplifier with DC volume control

TDA7052A/AT

## FUNCTIONAL DESCRIPTION

The TDA7052A/AT are mono BTL output amplifiers with DC volume control, designed for use in TV and monitors but also suitable for battery fed portable recorders and radios.

In conventional DC volume circuits the control or input stage is AC coupled to the output stage via external capacitors to keep the offset voltage low.

In the TDA7052A/AT the DC volume control stage is integrated into the input stage so that no coupling capacitors are required and yet a low offset voltage is maintained. At the same time the minimum supply remains low.

The BTL principle offers the following advantages:

- Lower peak value of the supply current
- The frequency of the ripple on the supply voltage is twice the signal frequency.

Thus a reduced power supply with smaller capacitors can be used which results in cost savings.

For portable applications there is a trend to decrease the supply voltage, resulting in a reduction of output power at conventional output stages. Using the BTL principle increases the output power.

The maximum gain of the amplifier is fixed at 35.5 dB. The DC volume control stage has a logarithmic control characteristic.

The total gain can be controlled from 35.5 dB to -44 dB. If the DC volume control voltage is below 0.3 V, the device switches to the mute mode.

The amplifier is short-circuit proof to ground,  $V_P$  and across the load. Also a thermal protection circuit is implemented. If the crystal temperature rises above +150 °C the gain will be reduced, so the output power is reduced.

Special attention is given to switch on and off clicks, low HF radiation and a good overall stability.

## LIMITING VALUES

In accordance with the Absolute Maximum System (IEC 134)

SYMBOL	PARAMETER	CONDITIONS	MIN.	MAX.	UNIT
$V_P$	supply voltage range		-	18	V
$I_{ORM}$	repetitive peak output current		-	1.25	A
$I_{OSM}$	non-repetitive peak output current		-	1.5	A
$P_{tot}$	total power dissipation	$T_{amb} \leq 25\%$			
	TDA7052A		-	1.25	W
	TDA7052AT		-	0.8	W
$T_{amb}$	operating ambient temperature range		-40	+85	°C
$T_{stg}$	storage temperature range		-55	+150	°C
$T_{vj}$	virtual junction temperature		-	+150	°C
$T_{sc}$	short-circuit time		-	1	hr
$V_2$	input voltage pin 2		-	8	V
$V_4$	input voltage pin 4		-	8	V

---

**1 W BTL mono audio amplifier with DC  
volume control**

---

**TDA7052A/AT****THERMAL RESISTANCE**

SYMBOL	PARAMETER	THERMAL RESISTANCE
$R_{th\ j-a}$	from junction to ambient in free air	
	TDA7052A	100 K/W
	TDA7052AT	155 K/W

**Notes to the thermal resistance**

TDA7052A:  $V_P = 6\text{ V}$ ;  $R_L = 8\ \Omega$ . The maximum sine-wave dissipation is 0.9 W.

Therefore  $T_{amb(max)} = 150 - 100 \times 0.9 = 60\text{ }^\circ\text{C}$ .

TDA7052AT:  $V_P = 6\text{ V}$ ;  $R_L = 16\ \Omega$ . The maximum sine-wave dissipation is 0.46 W.

Therefore  $T_{amb(max)} = 150 - 155 \times 0.46 = 78\text{ }^\circ\text{C}$ .

# 1 W BTL mono audio amplifier with DC volume control

TDA7052A/AT

**CHARACTERISTICS**
 $V_P = 6\text{ V}$ ;  $T_{\text{amb}} = 25\text{ }^\circ\text{C}$ ;  $f = 1\text{ kHz}$ ; TDA7052A:  $R_L = 8\text{ }\Omega$ ; TDA7052AT:  $R_L = 16\text{ }\Omega$ ; unless otherwise specified (see Fig.6).

SYMBOL	PARAMETER	CONDITIONS	MIN.	TYP.	MAX.	UNIT
$V_P$	positive supply voltage range		4.5	–	18	V
$I_P$	total quiescent current	$V_P = 6\text{ V}$ ; $R_L = \infty$ note 1	–	7	12	mA
<b>Maximum gain; <math>V_4 = 1.4\text{ V}</math></b>						
$P_O$	output power	THD = 10%				
	TDA7052A		1.0	1.1	–	W
	TDA7052AT		0.5	0.55	–	W
THD	total harmonic distortion					
	TDA7052A	$P_O = 0.5\text{ W}$	–	0.3	1	%
	TDA7052AT	$P_O = 0.25\text{ W}$	–	0.3	1	%
$G_v$	voltage gain		34.5	35.5	36.5	dB
$V_I$	input signal handling	$V_4 = 0.8\text{ V}$ ; THD < 1%	0.5	0.65	–	V
$V_{\text{no(rms)}}$	noise output voltage (RMS value)	$f = 500\text{ kHz}$ ; note 2	–	210	–	$\mu\text{V}$
B	bandwidth	–1 dB	–	20 Hz to 300 kHz	–	
SVRR	supply voltage ripple rejection	note 3	38	46	–	dB
$ V_{\text{off}} $	DC output offset voltage		–	0	150	mV
$Z_I$	input impedance (pin 2)		15	20	25	k $\Omega$
<b>Minimum gain; <math>V_4 = 0.5\text{ V}</math></b>						
$G_v$	voltage gain		–	–44	–	dB
$V_{\text{no(rms)}}$	noise output voltage (RMS value)	note 4	–	20	30	$\mu\text{V}$
<b>Mute position</b>						
$V_O$	output voltage in mute position	$V_4 \leq 0.3\text{ V}$ ; $V_I = 600\text{ mV}$	–	–	30	$\mu\text{V}$
<b>DC volume control</b>						
$\phi$	gain control range		75	80	–	dB
$I_4$	control current	$V_4 = 0.4\text{ V}$	60	70	80	$\mu\text{A}$

**Notes to the characteristics**

1. With a load connected to the outputs the quiescent current will increase, the maximum value of this increase being equal to the DC output offset voltage dividend by  $R_L$ .
2. The noise output voltage (RMS value) at  $f = 500\text{ kHz}$  is measured with  $R_S = 0\text{ }\Omega$  and bandwidth = 5 kHz.
3. The ripple rejection is measured with  $R_S = 0\text{ }\Omega$  and  $f = 100\text{ Hz}$  to 10 kHz. The ripple voltage of 200 mV, (RMS value) is applied to the positive supply rail.
4. The noise output voltage (RMS value) is measured with  $R_S = 5\text{ k}\Omega$  unweighted.

1 W BTL mono audio amplifier with DC volume control

TDA7052A/AT

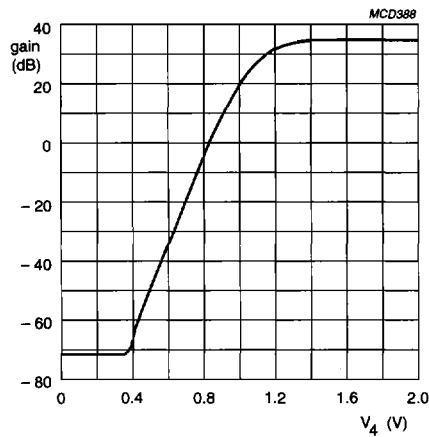

Fig.3 Gain control as a function of DC volume control.

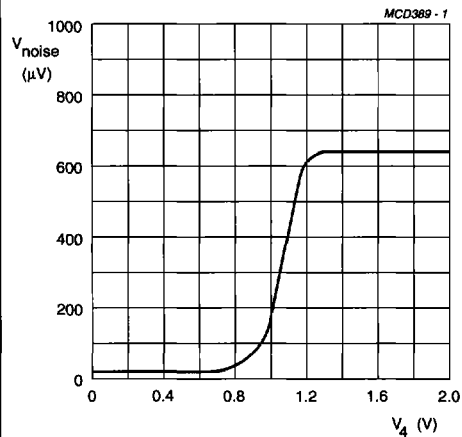

Fig.4 Noise output voltage as a function of DC volume control.

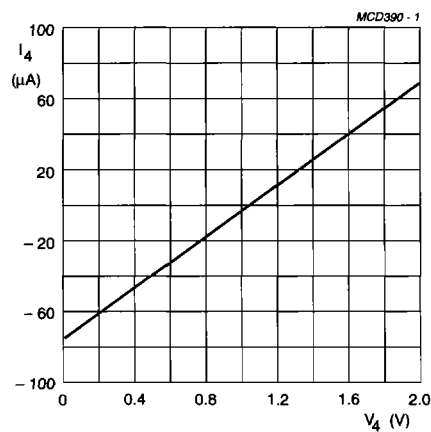
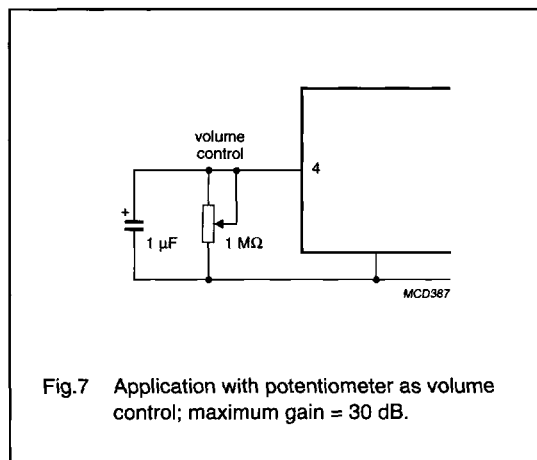
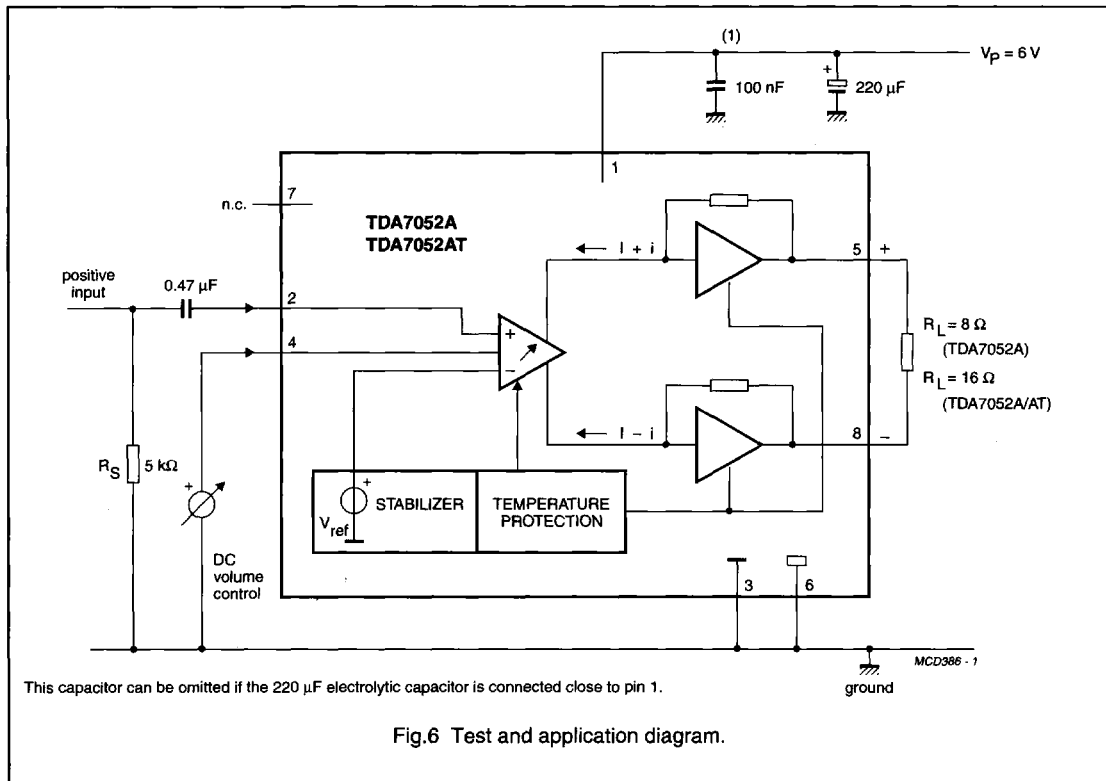

Fig.5 Control current as a function of DC volume control.

# 1 W BTL mono audio amplifier with DC volume control

## TDA7052A/AT

### APPLICATION INFORMATION









## Product Information

# TDA7052A/AT; 1 W BTL mono audio amplifier with DC volume control

Information as of 2002-05-14

 Stay informed Download  
datasheet

<input checked="" type="checkbox"/> <a href="#">General Description</a>	<input checked="" type="checkbox"/> <a href="#">Features</a>	 <a href="#">Applications</a>	<input checked="" type="checkbox"/> <a href="#">Datasheet</a>
 <a href="#">Blockdiagram</a>	<input checked="" type="checkbox"/> <a href="#">Buy online</a>	<input checked="" type="checkbox"/> <a href="#">Support &amp; tools</a>	
<input checked="" type="checkbox"/> <a href="#">Products &amp; packages</a>	<input checked="" type="checkbox"/> <a href="#">Parametrics</a>	<input checked="" type="checkbox"/> <a href="#">Similar</a>	

## Description

The TDA7052A/AT are mono BTL output amplifiers with DC volume control. They are designed for use in TV and monitors, but also suitable for battery-fed portable recorders and radios.

### Missing Current Limiter (MCL)

A MCL protection circuit is built-in. The MCL circuit is activated when the difference in current between the output terminal of each amplifier exceeds 100 mA (typical 300 mA). This level of 100 mA allows for headphone applications (single-ended).

## Features

- DC volume control
- Few external components
- Mute mode
- Thermal protection
- Short-circuit proof
- No switch-on and off clicks
- Good overall stability
- Low power consumption
- Low HF radiation
- ESD protected on all pins

## Datasheet

<u>Type number</u>	<u>Title</u>	<u>Publication release date</u>	<u>Datasheet status</u>	<u>Page count</u>	<u>File size (kB)</u>	<u>Datasheet</u>



TDA7052A/AT	1 W BTL mono audio amplifier with DC volume control	01-Jul-94	Product Specification	12	60	<a href="#">PDF</a> <a href="#">Download</a>
-------------	-----------------------------------------------------	-----------	-----------------------	----	----	----------------------------------------------

## Parametrics

Type number	Package	REMARKS	Supply voltage (V)typ.
TDA7052A/N2	SOT97	DC volume control, 36 dB gain	4.5 to 18
TDA7052AT/N2	<a href="#">SOT96</a> (SO8, MS-012AA, 076E03S)	DC volume control, 36 dB gain	4.5 to 18

## Products, packages, availability and ordering

Type number	North American		marking/packing <a href="#">PDF</a> <a href="#">IC packing info</a>	package	device status	buy online
	Type number	Order code (12nc)				
TDA7052A/N2		9350 544 10112	Standard Marking * Tube	<a href="#">SOT97-1</a> (DIP8)	Full production	<a href="#">BUY ONLINE</a>
TDA7052AT/N2		9350 544 00112	Standard Marking * Tube	<a href="#">SOT96</a> (SO8)	Full production	<a href="#">BUY ONLINE</a>
		9350 544 00118	Standard Marking * Reel Pack, SMD, 13"	<a href="#">SOT96</a> (SO8)	Full production	<a href="#">BUY ONLINE</a>

Products in the above table are all in production. Some variants are discontinued; [click here](#) for information on these variants.

## Find similar products:

[MORE](#) [TDA7052A/AT](#) links to the similar products page containing an overview of products that are similar in function or related to the Type number(s) as listed on this page. The similar products page includes products from the same catalog tree(s) , relevant selection guides and products from the same functional category.

## Support & tools

[PDF](#) [Complete CTO analog cordless chipset Introduction](#)(date 01-Dec-97)