

Optocoupler—DIP Package

OPIA800 through OPID804

Features:

- 5,000 Vrms electrical isolation
- Choice of a Single and Dual LED
- Choice of Phototransistor or Photologic® Sensor
- Low-cost plastic Dual-In-Line (DIP) package

Agency Approvals:

- UL Certification No: E58730
- VDE pending

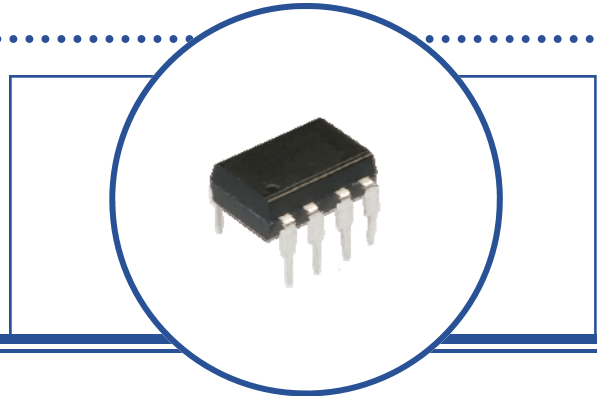

Description:

The OPIA800D through OPID804D optocouplers are designed for applications that utilize a digital output (Photologic®) in a dual-in-line package. Isolation voltage from 2,500 to 5,000 Volts RMS product are designed for some of the most stringent power system isolation requirements.

Theory of operation: The LED transmitter is used to illuminate the Photosensor providing electrical isolation between two power systems while maintaining the ability to transmit information from one power system to the other. In many applications, analog or digital signals may be required to be transmitted between two power systems while maintaining isolation between the power systems up to 5,000 volts RMS. A variety of LED and photosensor configurations are available depending on the system requirements

$$CTR = \frac{\text{Photosensor Current}}{\text{LED Current}} = \frac{20 \text{ mA}}{10 \text{ mA}} * 100 = 200$$

All DIP product is shipped in a shipping tube with “TU” identified on the end of the part number.
Example: OPI800DTU is a 8-Pin DIP shipped in a tube (TU).

Applications:

- High voltage isolation
- PCBoard power system isolation
- Industrial equipment power isolation
- Medical equipment power isolation
- Office equipment



RoHS

OPTEK reserves the right to make changes at any time in order to improve design and to supply the best product possible.

Optocoupler—DIP Package

OPIA800 through OPID804



Analog Output Devices Ordering Information

Part Number	Isolation Voltage Max. (Vrms)	CTR Min/Typ/Max	Typ. Tplh / Tphl (µs) [R _L = ohms]	Package	Configuration
OPIA800	2,500	300 / 1,600 / -	7 / 2 [2.2 K]	8 Pin DIP	A K—K A B C E (Dar)
OPIA801	2,500	500 / 1,600 / -	10 / 5 [4.7 K]	8 Pin DIP	A K—K A B C E (Dar)
OPIA802	2,500	15 / 43 / -	0.3 / 0.3 [1.9 K]	8 Pin DIP	A K—K A C E
OPIA803	5,000	5 / 43 / -	0.4 / 0.3 [4.1 K]	8 Pin DIP	A K—K A C E

Digital Output Devices Ordering Information

Part Number	Isolation Voltage Max. (Vrms)	Typ. Tr / Tf (ns) [R _L = 350 ohms]	Typ. Tplh / Tphl (ns) [R _L = ohms]	Package	Configuration
OPID804	5,000	30 / 30	45 / 45 [350]	8 Pin DIP	A K—NAND

Configuration: Definition of Terms
LED Identification—Sensor Identification

LED	A = Anode	K = Cathode			
Sensor	10K Logic	10K Inverted Logic	NAND Gate	NAND Gate	
	K = Cathode	A = Anode	B = Base	C = Collector	E = Emitter

Packaging Part Number Suffix: **TU** = Ship in Tubes, **TR** = Ship on Tape and Reel Example: OPID606DTR

Part Number	Pin #							
	1	2	3	4	5	6	7	8
OPIA800		A	K		E	C	C-B	K-C
OPIA801		A	K		E	C	C-B	K-C
OPIA802		A	K		E	C	A-B	K
OPIA803		A	K		E	C	A-B	K
OPID804		A	K		GND	Output	Enable	Vcc

Package Outline Dimensions and Schematics: Top-View

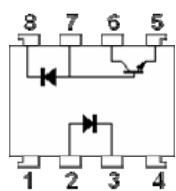

OPIA802
OPIA803

Symbol	Definition
A	Anode
B	Base
C	Collector
E	Emitter
K	Cathode

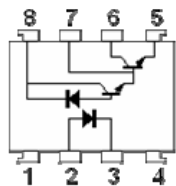

OPIA800
OPIA801

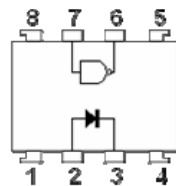

OPIA804

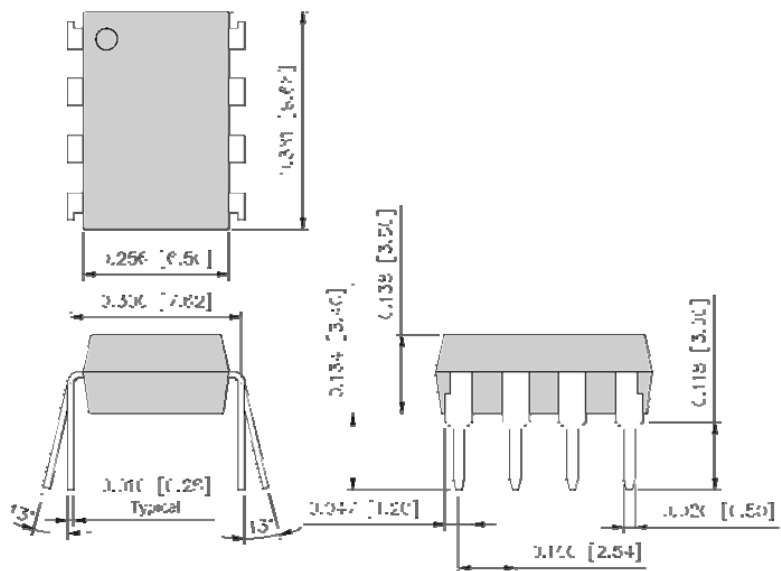

OPTEK reserves the right to make changes at any time in order to improve design and to supply the best product possible.

Optocoupler—DIP Package

OPIA800 through OPID804



Absolute Maximum Ratings ($T_A = 25^\circ\text{C}$ unless otherwise noted)

Storage Temperature	-55° C to +125° C
Operating Temperature OPIA800 OPIA801 OPIA802 OPIA803 OPID804	-40° C to +115° C 0° C to +125° C -55° C to +115° C -55° C to +100° C 0° C to +85° C
Isolation voltage (1 minute) OPID804 OPIA800, OPIA801, OPIA802, OPIA803	5,000 Vrms 2,500 Vrms
Lead Soldering Temperature (1/16" (1.6 mm) from case for 5 seconds with soldering iron)	260° C

Input Diode

Continuous Forward Current OPIA802, OPIA803, OPID804 OPIA800, OPIA801	25 mA 20 mA
Peak Forward current (1 μs pulse width, 300 pps) OPIA800, OPIA801, OPIA802, OPIA803 OPID804	1 A 40 mA
Reverse Voltage OPIA800D, OPIA801D, OPIA802D, OPIA803D, OPID804D	5 V
Power Dissipation OPIA802D, OPIA803D, OPID804D OPIA800D, OPIA801D	45 mW 35 mW

Absolute Maximum Ratings ($T_A = 0^\circ\text{C}$ to 70°C unless otherwise specified)

Output IC

V _{cc} —Collector-Emitter Voltage OPIA800D OPIA801D OPIA802D, OPIA803D	-0.5 V to +7 V -0.5 V to +18 V -0.5 V to +15 V
Collector Current OPIA802D, OPIA803D OPIA800D, OPIA801D	8 mA 60 mA
Power Dissipation OPIA800D, OPIA801D, OPIA802D, OPIA803D	100 mW

Output NAND Gate—OPID804D

V _{cc} —Supply voltage	7 V
Enable voltage	5.5 V
High Level Output voltage	7 V
Low Level Output current	50 mA
Output Collector Power Dissipation	85 mW

OPTEK reserves the right to make changes at any time in order to improve design and to supply the best product possible.

Optocoupler—DIP Package

OPIA800 through OPID804



Electrical Characteristics: OPIA800D

Parameter	Symbol	Conditions	MIN.	TYP.	MAX.	Unit
*6 Current transfer ratio	CTR	IF=1.6mA Vo=0.4V,Vcc=4.5V	300	1600	-	%
Logic (0) output voltage	VOL	IF=1.6mA Io=4.8mA,Vcc=4.5V	-	0.1	0.4	V
Logic (1) output current	IOH	IF=0,Vo=Vcc=7V	-	0.1	250	uA
Logic (0) supply current	ICCL	IF=1.6mA,Vo=open,Vcc=5V	-	0.5	-	mA
Logic (1) supply current	ICCH	IF=0,Vo=open,Vcc=5V	-	10	-	nA
Input forward voltage	VF	Ta=25°C,IF=1.6mA	-	1.5	1.7	V
Input forward voltage temperature coefficient	$\Delta VF/\Delta Ta$	IF=1.6mA	-	-1.9	-	mV/°C
Input reverse voltage	BVR	Ta=25°C,IR=10uA	5.0	-	-	V
Input capacitance	CIN	VF=0,f=1MHz	-	60	-	pF
*7 Leak current(input-output)	II-O	Ta=25°C,45% RH VI-O=3kVDC,t=5s	-	-	1.0	uA
*7 Isolation resistance(input-output)	RI-O	VI-O=500VDC	-	10 ¹²	-	Ω
*7 Capacitance(input-output)	CI-O	f=1MHz	-	0.6	-	pF

*6 Current transfer ratio is a ratio of input current and output current expressed in %.

*7 Measured as 2-pin element (Short 1,2,3,4 and 5,6,7,8)

OPTEK reserves the right to make changes at any time in order to improve design and to supply the best product possible.

Optocoupler—DIP Package

OPIA800 through OPID804



Switching Characteristics: OPIA800D

Parameter	Symbol	Conditions	MIN.	TYP.	MAX.	Unit
*8 Propagation delay time Output (1)-->(0)	t_{PHL}	$R_L=2.2k\Omega, I_F=1.6mA$	-	2	10	μS
*8 Propagation delay time Output (0)-->(1)	t_{PLH}	$R_L=2.2k\Omega, I_F=1.6mA$	-	7	35	μS
*9 Instantaneous common mode rejection voltage "Output (1)"	CMH	$I_F=0, V_{CM}=10Vp-p, R_L=2.2k\Omega$	-	500	-	V/uS
*10 Instantaneous common mode rejection voltage "Output (0)"	CML	$I_F=1.6mA, V_{CM}=10Vp-p, R_L=2.2k\Omega$	-	-500	-	V/uS

*9 Instantaneous common mode rejection voltage "output(1)" represents a common voltage variation that can hold the output above (1) level ($V_o > 2.0V$).

*10 Instantaneous common mode rejection voltage "output(1)" represents a common voltage variation that can hold the output above (0) level ($V_o > 0.8V$).

*8 Test Circuit Propagation Delay Time

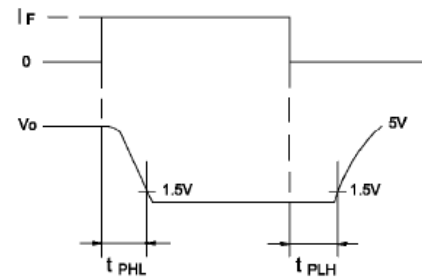
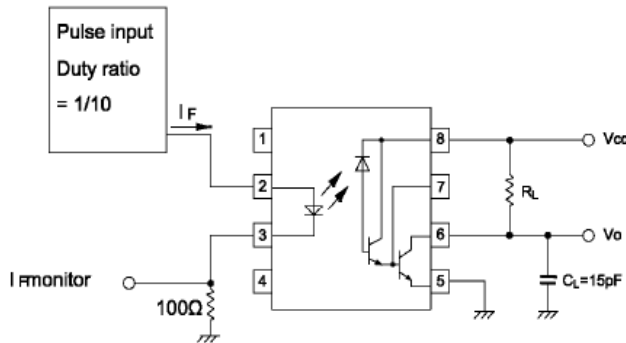

*10 Test Circuit for Instantaneous Common Mode Rejection Voltage

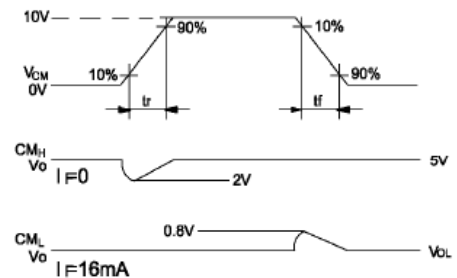
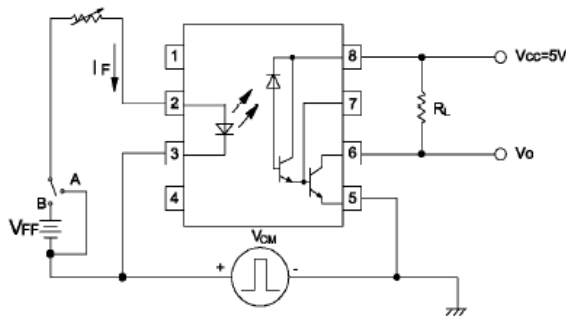

OPTEK reserves the right to make changes at any time in order to improve design and to supply the best product possible.

Optocoupler—DIP Package

OPIA800 through OPID804



Electrical Characteristics: OPIA801D

(T_A = 25°C)

Parameter	Symbol	Conditions	MIN.	TYP.	MAX.	Unit
*6 Current transfer ratio	CTR(1)	I _F =0.5mA, V _O =0.4V, V _{CC} =4.5V	400	1800	-	%
	CTR(2)	I _F =1.6mA, V _O =0.4V, V _{CC} =4.5V	500	1600	-	%
Logic (0) output voltage	V _{OL} (1)	I _F =6.4mA, I _O =1.6mA, V _{CC} =4.5V	-	0.1	0.4	V
	V _{OL} (2)	I _F =5mA, I _O =15mA, V _{CC} =4.5V	-	0.1	0.4	V
	V _{OL} (3)	I _F =12mA, I _O =24mA, V _{CC} =4.5V	-	0.1	0.4	V
Logic (1) output current	I _{OH}	I _F =0, V _O =V _{CC} =18V	-	0.05	100	uA
Logic (0) supply current	I _{CCL}	I _F =1.6mA, V _O =open, V _{CC} =5V	-	0.5	-	mA
Logic (1) supply current	I _{CCH}	I _F =0, V _F =open, V _{CC} =5V	-	10	-	nA
Input forward voltage	V _F	T _a =25°C, I _F =1.6mA	-	1.5	1.7	V
Input forward voltage temperature coefficient	ΔV _F /ΔT _a	I _F =1.6mA	-	-1.9	-	mV/°C
Input reverse voltage	BV _R	T _a =25°C, I _R =10uA	5.0	-	-	V
Input capacitance	C _{IN}	V _F =0, f=1MHz	-	60	-	pF
*7 Leak current (input-output)	I _{I-O}	T _a =25°C, 45%RH V _{I-O} =3KVDC, t=5s	-	-	1.0	uA
*7 Isolation resistance (input-output)	R _{I-O}	V _{I-O} =500VDC	-	10 ¹²	-	Ω
*7 Capacitance (input-output)	C _{I-O}	f=1MHz	-	0.6	-	pF

*6 Current transfer ratio is a ratio of input current and output current expressed in %.

*7 Measured as 2-pin element (Short 1,2,3,4 and 5,6,7,8)

OPTEK reserves the right to make changes at any time in order to improve design and to supply the best product possible.

Optocoupler—DIP Package

OPIA800 through OPID804



Switching Characteristics: OPIA801D

Parameter	Symbol	Conditions	MIN.	TYP.	MAX.	Unit
*8 Propagation delay time Output (1) → (0)	t_{PHL}	$R_L=4.7K\Omega, I_F=0.5mA$	-	5	25	μS
		$R_L=270\Omega, I_F=12mA$	-	0.3	1	μS
*8 Propagation delay time Output (0) → (1)	t_{PLH}	$R_L=4.7K\Omega, I_F=0.5mA$	-	10	60	μS
		$R_L=270\Omega, I_F=12mA$	-	1.5	7	μS
*9 *10 Instantaneous common mode rejection voltage “ Output (1) “	CM_H	$I_F=0, V_{CM}=10V_{P-P},$ $R_L=2.2K\Omega$	-	500	-	$V/\mu S$
*9 *10 Instantaneous common mode rejection voltage “ Output (0) “	CM_L	$I_F=1.6mA, V_{CM}=10V_{P-P},$ $R_L=2.2K\Omega$	-	-500	-	$V/\mu S$

*9 Instantaneous common mode rejection voltage “output(1)” represents a common voltage variation that can hold the output above (1) level ($V_o > 2.0V$).

*10 Instantaneous common mode rejection voltage “output(1)” represents a common voltage variation that can hold the output above (0) level ($V_o > 0.8V$).

*8 Test Circuit Propagation Delay Time

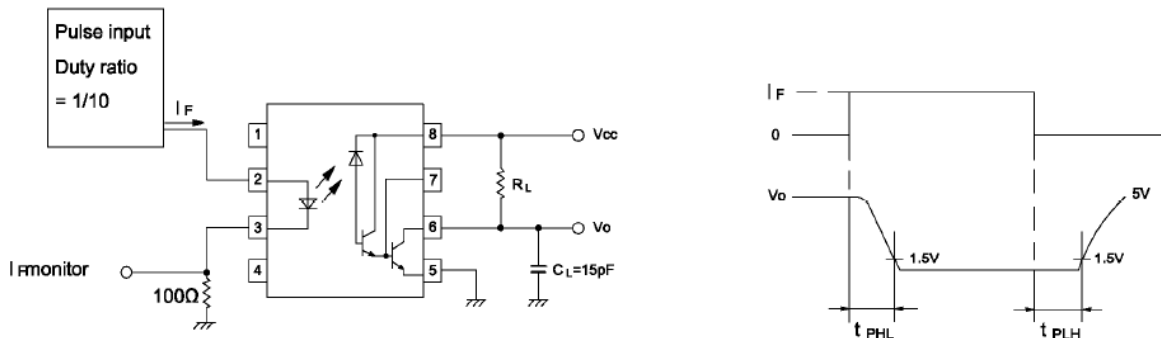

*10 Test Circuit for Instantaneous Common Mode Rejection Voltage

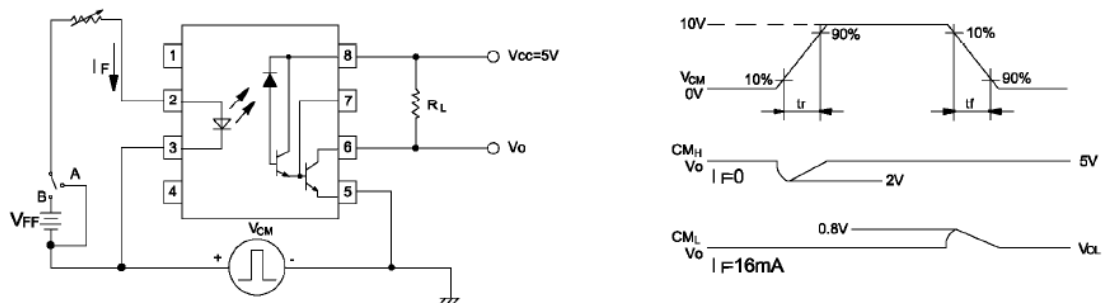

OPTEK reserves the right to make changes at any time in order to improve design and to supply the best product possible.

Optocoupler—DIP Package

OPIA800 through OPID804



Electrical Characteristics: OPIA802D

(T_A = 0 to +70°C unless otherwise specified)

Parameter	Symbol	Conditions	MIN.	TYP.	MAX.	Unit
*5 Current transfer ratio	CTR(1)	T _a =25°C, I _F =16mA V _O =0.4V, V _{CC} =4.5V	19	40	-	%
	CTR(2)	I _F =16mA V _O =0.5V, V _{CC} =4.5V	15	43	-	%
Logic (0) output voltage	V _{OL}	*6 V _{CC} =4.5V, I _F =16mA	-	0.1	0.4	V
Logic (1) output current	I _{OH} (1)	T _a =25°C, I _F =0 V _O =V _{CC} =5.5V	-	3.0	500	nA
	I _{OH} (2)	T _a =25°C, I _F =0 V _O =V _{CC} =15V	-	0.01	1.0	uA
	I _{OH} (3)	V _{CC} =V _O =15V, I _F =0	-	-	50	uA
Logic (0) supply current	I _{CCL}	I _F =16mA V _O =open, V _{CC} =15V	-	200	-	uA
Logic (1) supply current	I _{CCH} (1)	T _a =25°C, I _O =0 V _F =open, V _{CC} =15V	-	0.02	1.0	uA
	I _{CCH} (2)	I _O =0 V _O =open, V _{CC} =15V	-	-	2.0	uA
Input forward voltage	V _F	T _a =25°C, I _F =16mA	-	1.7	1.95	V
Input forward voltage temperature coefficient	ΔV _F /ΔT _a	I _F =16mA	-	-1.9	-	mV/°C
Input reverse voltage	BV _R	T _a =25°C, I _R =10uA	5.0	-	-	V
Input capacitance	C _{IN}	V _F =0, f=1MHz	-	60	-	pF
*7 Leak current (input-output)	I _{I-O}	T _a =25°C, 45%RH V _{I-O} =3KVDC, t=5s	-	-	1.0	uA
*7 Isolation resistance (input-output)	R _{I-O}	V _{I-O} =500VDC	-	10 ¹²	-	Ω
*7 Capacitance (input-output)	C _{I-O}	f=1MHz	-	0.6	-	pF
Transistor current amplification factor	h _{FE}	V _O =5V, I _O =3mA	-	70	-	

*5 Current transfer ratio is a ratio of input current and output current expressed in %.

*6 I_O = 2.4mA

*7 Measured as 2-pin element (Short 1,2,3,4 and 5,6,7,8)

OPTEK reserves the right to make changes at any time in order to improve design and to supply the best product possible.

Optocoupler—DIP Package

OPIA800 through OPID804



Switching Characteristics: OPIA802D

($T_A = 25^\circ\text{C}$, $V_{CC}=5\text{V}$, $I_F=16\text{mA}$)

Parameter	Symbol	Conditions	MIN.	TYP.	MAX.	Unit
*8 Propagation delay time *9 Output (1) \rightarrow (0)	t_{PHL}	$R_L=1.9\text{K}\Omega$	-	0.3	0.8	μS
*8 Propagation delay time *9 Output (0) \rightarrow (1)	t_{PLH}	$R_L=1.9\text{K}\Omega$	-	0.3	0.8	μS
*10 Instantaneous common mode rejection voltage *11 " Output (1) "	CM_H	$I_F=0$, $V_{CM}=10\text{V}_{P-P}$	-	1000	-	$\text{V}/\mu\text{S}$
*10 Instantaneous common mode rejection voltage *11 " Output (0) "	CM_L	$I_F=16\text{mA}$, $V_{CM}=10\text{V}_{P-P}$	-	-1000	-	$\text{V}/\mu\text{S}$
*12 Bandwidth	BW	$R_L=100\Omega$	-	2.0	-	MHz

*8 $R_L = 1.9\text{k}$ ohms is equivalent to on LSTTL and 5.6k ohm pull-up resistor.

*9 Instantaneous common mode rejection voltage "output(1)" represents a common voltage variation that can hold the output above (1) level ($V_o > 2.0\text{V}$).

*10 Instantaneous common mode rejection voltage "output(1)" represents a common voltage variation that can hold the output above (0) level ($V_o > 0.8\text{V}$).

*11 Bandwidth represents a point where AC input goes down by 3dB.

*9 Test Circuit Propagation Delay Time

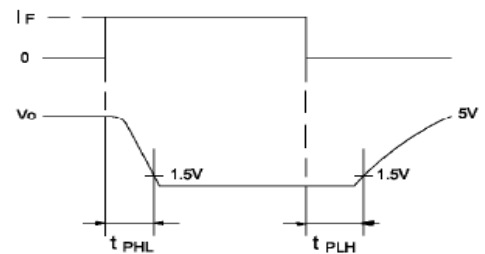
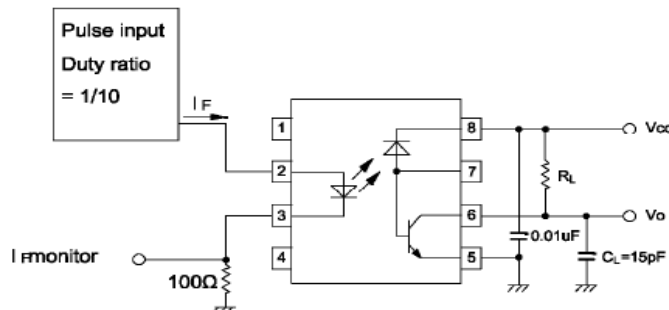

*11 Test Circuit for Instantaneous Common Mode Rejection Voltage

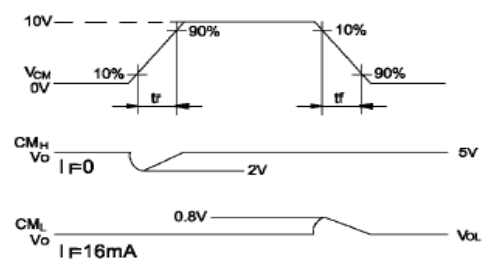
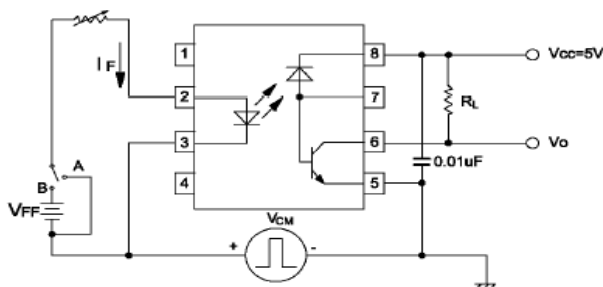

OPTEK reserves the right to make changes at any time in order to improve design and to supply the best product possible.

Optocoupler—DIP Package

OPIA800 through OPID804



Electrical Characteristics: OPIA803D

($T_A = 0$ to $+70^\circ\text{C}$ unless otherwise specified)

Parameter	Symbol	Conditions	MIN.	TYP.	MAX.	Unit
*5 Current transfer ratio	CTR(1)	$T_A=25^\circ\text{C}$, $I_F=16\text{mA}$ $V_O=0.4\text{V}$, $V_{CC}=4.5\text{V}$	7	40	-	%
	CTR(2)	$I_F=16\text{mA}$ $V_O=0.5\text{V}$, $V_{CC}=4.5\text{V}$	5	43	-	%
Logic (0) output voltage	V_{OL}	*6 $V_{CC}=4.5\text{V}$, $I_F=16\text{mA}$	-	0.1	0.4	V
Logic (1) output current	$I_{OH}(1)$	$T_A=25^\circ\text{C}$, $I_F=0$ $V_O=V_{CC}=5.5\text{V}$	-	3.0	500	nA
	$I_{OH}(2)$	$T_A=25^\circ\text{C}$, $I_F=0$ $V_O=V_{CC}=15\text{V}$	-	0.01	1.0	μA
	$I_{OH}(3)$	$V_{CC}=V_O=15\text{V}$, $I_F=0$	-	-	50	μA
Logic (0) supply current	I_{CCL}	$I_F=16\text{mA}$ $V_O=\text{open}$, $V_{CC}=15\text{V}$	-	200	-	μA
Logic (1) supply current	$I_{CCH}(1)$	$T_A=25^\circ\text{C}$, $I_O=0$ $V_F=\text{open}$, $V_{CC}=15\text{V}$	-	0.02	1.0	μA
	$I_{CCH}(2)$	$I_O=0$ $V_O=\text{open}$, $V_{CC}=15\text{V}$	-	-	2.0	μA
Input forward voltage	V_F	$T_A=25^\circ\text{C}$, $I_F=16\text{mA}$	-	1.7	1.95	V
Input forward voltage temperature coefficient	$\Delta V_F/\Delta T_A$	$I_F=16\text{mA}$	-	-1.9	-	$\text{mV}/^\circ\text{C}$
Input reverse voltage	BV_R	$T_A=25^\circ\text{C}$, $I_R=10\mu\text{A}$	5.0	-	-	V
Input capacitance	C_{IN}	$V_F=0$, $f=1\text{MHz}$	-	60	-	pF
*7 Leak current (input-output)	I_{LO}	$T_A=25^\circ\text{C}$, 45%RH $V_{LO}=3\text{KVDC}$, $t=5\text{s}$	-	-	1.0	μA
*7 Isolation resistance (input-output)	R_{LO}	$V_{LO}=500\text{VDC}$	-	10^{12}	-	Ω
*7 Capacitance (input-output)	C_{LO}	$f=1\text{MHz}$	-	0.6	-	pF
Transistor current amplification factor	h_{FE}	$V_O=5\text{V}$, $I_O=3\text{mA}$	-	70	-	

*5 Current transfer ratio is a ratio of input current and output current expressed in %.

*6 $I_O = 1.1\text{mA}$

*7 Measured as 2-pin element (Short 1,2,3,4 and 5,6,7,8)

OPTEK reserves the right to make changes at any time in order to improve design and to supply the best product possible.

Optocoupler—DIP Package

OPIA800 through OPID804



Switching Characteristics: OPIA803D

($T_A = 25^\circ\text{C}$, $V_{CC}=5\text{V}$, $I_F=16\text{mA}$)

Parameter	Symbol	Conditions	MIN.	TYP.	MAX.	Unit
*8 Propagation delay time *9 Output (1) \rightarrow (0)	t_{PHL}	$R_L=4.1\text{K}\Omega$	-	0.3	1.5	μS
*8 Propagation delay time *9 Output (0) \rightarrow (1)	t_{PLH}	$R_L=4.1\text{K}\Omega$	-	0.4	1.5	μS
*10 Instantaneous common mode rejection voltage *11 "Output (1)"	CM_H	$I_F=0$, $V_{CM}=10\text{V}_{P-P}$	-	1000	-	$\text{V}/\mu\text{S}$
*10 Instantaneous common mode rejection voltage *11 "Output (0)"	CM_L	$I_F=16\text{mA}$, $V_{CM}=10\text{V}_{P-P}$	-	-1000	-	$\text{V}/\mu\text{S}$
*12 Bandwidth	BW	$R_L=100\Omega$	-	2.0	-	MHz

*8 $R_L = 4.1\text{k}$ ohms is equivalent to on LSTTL and 6.1k ohm pull-up resistor.

*9 Instantaneous common mode rejection voltage "output(1)" represents a common voltage variation that can hold the output above (1) level ($V_o > 2.0\text{V}$).

*10 Instantaneous common mode rejection voltage "output(1)" represents a common voltage variation that can hold the output above (0) level ($V_o > 0.8\text{V}$).

*11 Bandwidth represents a point where AC input goes down by 3dB.

*9 Test Circuit Propagation Delay Time

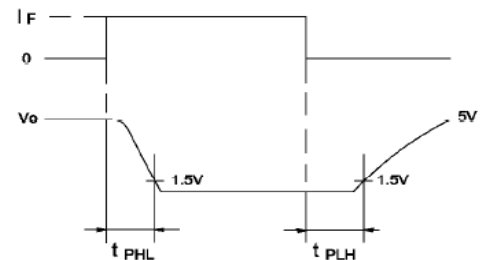
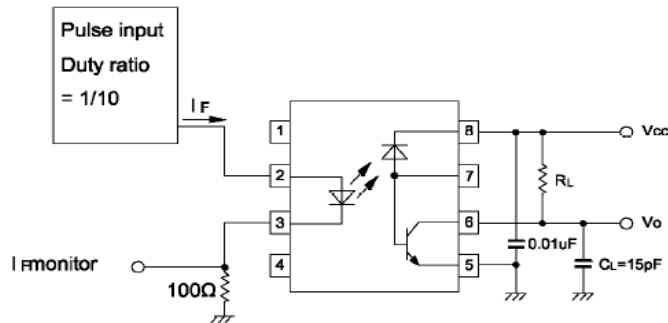

*11 Test Circuit for Instantaneous Common Mode Rejection Voltage

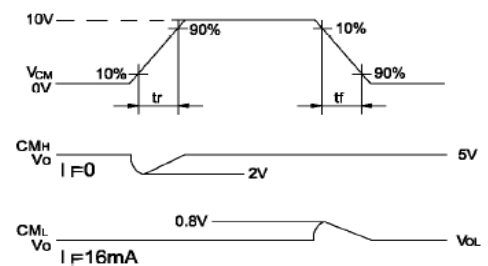
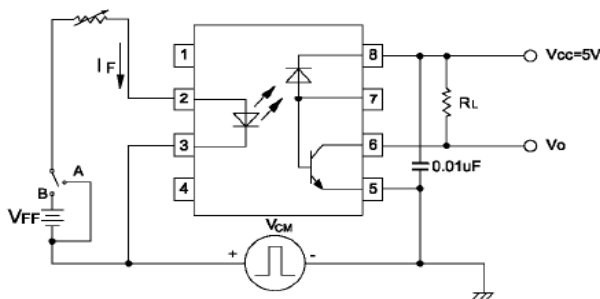

OPTEK reserves the right to make changes at any time in order to improve design and to supply the best product possible.

Optocoupler—DIP Package

OPIA800 through OPID804



Electrical Characteristics: OPID804D

($T_A = 0$ to $+70^\circ\text{C}$ unless otherwise specified)

SYMBOL	PARAMETER	MIN	TYP	MAX	UNITS	TEST CONDITIONS
--------	-----------	-----	-----	-----	-------	-----------------

Input Diode

V_F	Forward Voltage (*4)	-	1.6	1.8	V	$I_F = 10\text{ mA}$, $T_A = 25^\circ\text{C}$
BV_R	Reverse Breakdown Voltage	5	-	-	V	$I_R = 10\ \mu\text{A}$, $T_A = 25^\circ\text{C}$
C_{IN}	Input Capacitance	-	60	-	pf	$V_F = 0.0\text{ V}$, $f = 1\text{ MHz}$

Output Photologic

V_{OL}	Low Level Output Voltage	-	0.4	0.6	V	$I_{OL} = 13\text{ mA}$, $V_{CC} = 5.5\text{ V}$, $I_F = 5\text{ mA}$, $V_{EH}=2\text{V}$
I_{OH}	High Level Output Current	-	2	250	μA	$V_{CC}=5.5\text{ V}$, $V_O=5.5\text{ V}$, $V_E=2.0\text{ V}$, $I_F=250\ \mu\text{A}$
I_{EH}	High Level Enable Current	-	-0.8	-	mA	$V_{CC} = 5.5\text{ V}$, $V_E = 2.0\text{ V}$
I_{EL}	Low Level Enable Current	-2.0	-1.2	-	mA	$V_{CC} = 5.5\text{ V}$, $V_E = 2.0\text{ V}$
I_{CCL}	Low Level Output Current	-	13	18	mA	$V_{CC} = 5.5\text{ V}$, $V_E = 0.5\text{ V}$, $I_F = 10\text{ mA}$
I_{CCH}	High Level Output Current	-	7	15	mA	$V_{CC} = 5.5\text{ V}$, $V_E = 0.5\text{ V}$, $I_F = 0\text{ mA}$
I_{I-O}	Leakage Current	-	-	1.0	mA	$V_{I-O} = 3,000\text{ V}$, $T_A = 25^\circ\text{C}$, $t = 5\text{ s}$, $RH = 45\%$
t_{EHL}	Enable Propagation delay "High to Low" (*8)	-	15	-	ns	$V_{EH} = 3.0\text{ V}$, $V_{EL} = 0.5\text{ V}$, $R_L = 350\ \Omega$, $I_F = 7.5\text{ mA}$, $C_{LOAD} = 15\text{ pf}$
t_{ELH}	Enable Propagation delay "Low to High" (*8)	-	40	-		
I_{FHL} / I_{FLH}	Hysteresis	-	0.8	-	Ratio	$V_{CC} = 5\text{ V}$, $R_L = 280\ \Omega$
R_{I-O}	Input-Output Isolation resistance (*5)	-	10^{12}	-	ohm	$V_{I-O} = 500\text{ V}$, $T_A = 25^\circ\text{C}$
C_{I-O}	Input-Output Capacitance (*5)	-	0.6	-	pf	$f = 1\text{ MHz}$, $T_A = 25^\circ\text{C}$
$t_{PHL} \& t_{PLH}$	Propagation delay "High to Low" and "Low to High" (*7)	-	45	75	ns	$V_{CC} = 5\text{ V}$, $R_L = 350\ \Omega$, $I_F = 7.5\text{ mA}$, $C_{LOAD} = 15\text{ pf}$, $T_A = 25^\circ\text{C}$
$t_R \& t_F$	Rise and Fall Time	-	30	-		
CM_H	Instantaneous common mode rejection voltage "High Output" (*9)	-	500	-	V/us	$V_{CM} = 10\text{ V}$, $R_L = 350\ \Omega$, $I_F = 0\text{ mA}$, $V_O = 2.0\text{ V}$
CM_L	Instantaneous common mode rejection voltage "Low Output" (*9)	-	-500	-		$V_{CM} = 10\text{ V}$, $R_L = 350\ \Omega$, $I_F = 5\text{ mA}$, $V_O = 0.8\text{ V}$

Notes: (Typical values are all at $V_{CC} = 5\text{V}$, $T_A = 25^\circ\text{C}$.)

*5 Measured as 2-Pin element. Connect pins 2 and 3, connect pins 5,6,7 and 8.

*6 DC current transfer ratio is defined as the ratio of output collector current to forward bias input current.

*7 Refer to Figure 1.

*8 Refer to Figure 2.

*9 CM_H represents a common mode voltage ignorable rise time ratio that can hold logic (1) state in output.

CM_L represents a common mode voltage ignorable fall time ratio that can hold logic (0) state in output.

OPTEK reserves the right to make changes at any time in order to improve design and to supply the best product possible.

Optocoupler—DIP Package

OPIA800 through OPID804

Recommended Operating Conditions: OPIA804D

Parameter	Symbol	Min	Max	Unit
Low level input current	I_{FL}	0	250	μA
High level input current	I_{FH}	7.0	15	mA
High level enable voltage	V_{EH}	2.0	V_{CC}	V
Low level enable voltage	V_{EL}	0	0.8	V
Supply voltage	V_{CC}	4.5	5.5	V
Fanout (TTL load)	N	-	8	-
Operating temperature	T_{opr}	0	70	$^{\circ}\text{C}$

Truth Table

Input	Enable	Ouput
H	H	L
L	H	H
H	L	H
L	L	H

Circuit Block Diagram

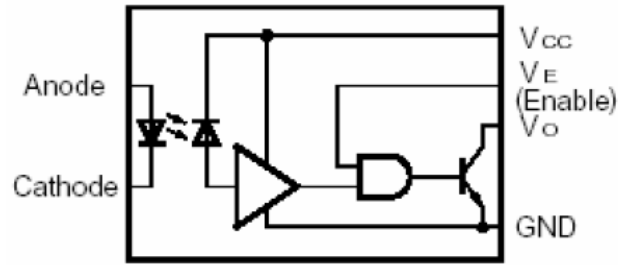
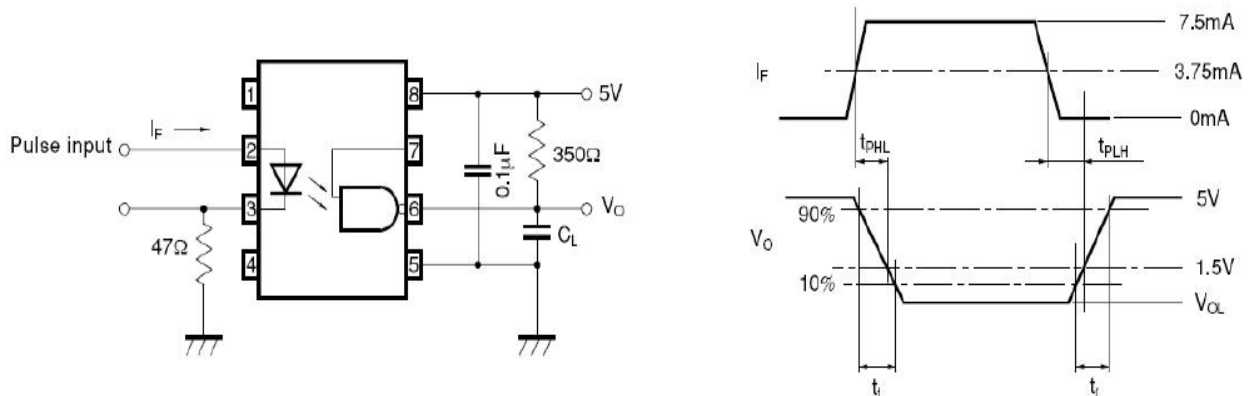

Figure 1.

Test Circuit Propagation Delay Time



OPTEK reserves the right to make changes at any time in order to improve design and to supply the best product possible.

Test Circuit for Enable Propagation Delay Time

Figure 2.

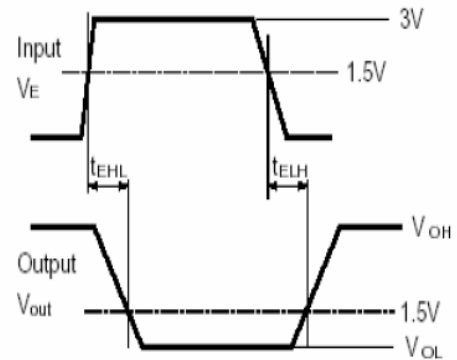
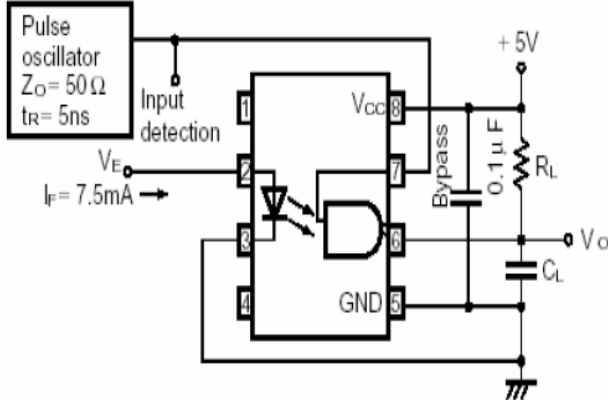
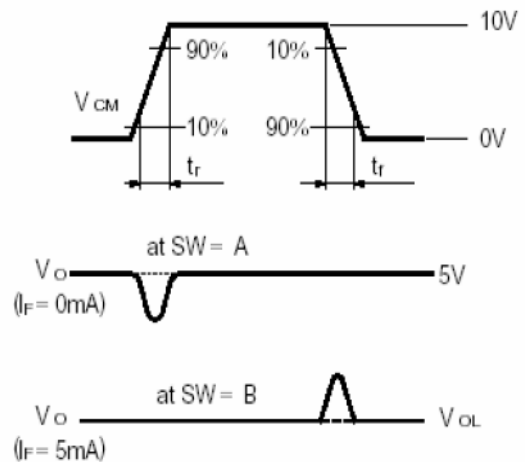
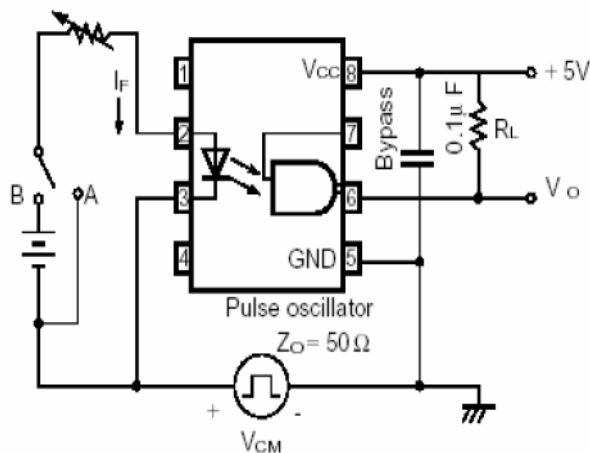

Figure 3.

Test Circuit for Instantaneous Common Mode Rejection Voltage



OPTEK reserves the right to make changes at any time in order to improve design and to supply the best product possible.

OPIA800

Fig.1 LED Forward Current vs. Forward Voltage

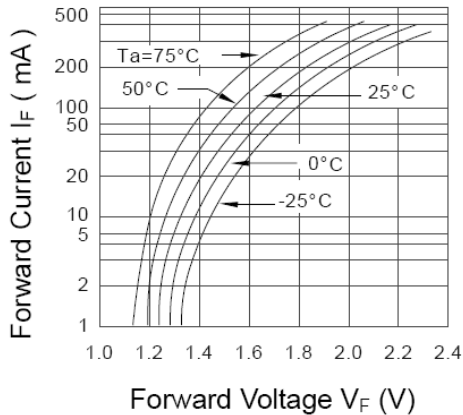

Fig.2 LED Forward Current vs. Ambient Temperature

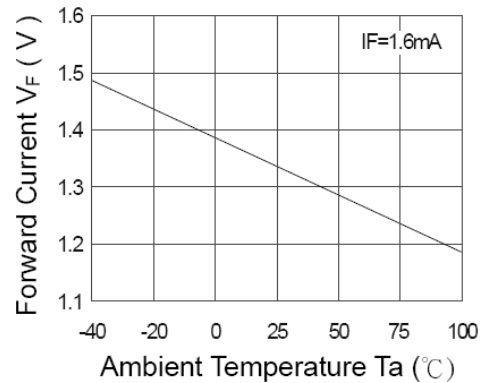

Fig.3 Response and Fall Time vs. Load Resistance

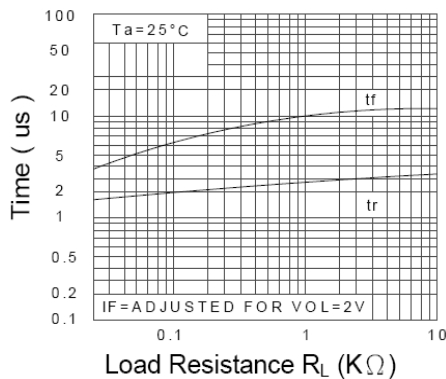

Fig.4 Current Transfer Ratio vs. Forward Current

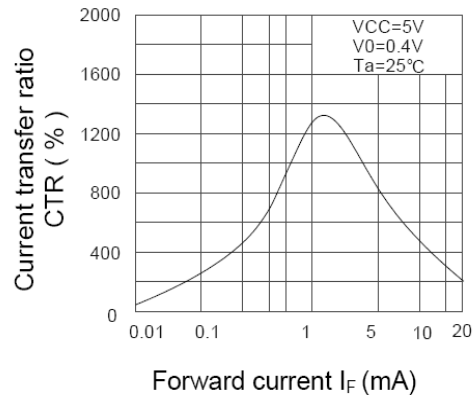

Fig.5 Current Transfer Ratio vs. Base-Emitter Resistance

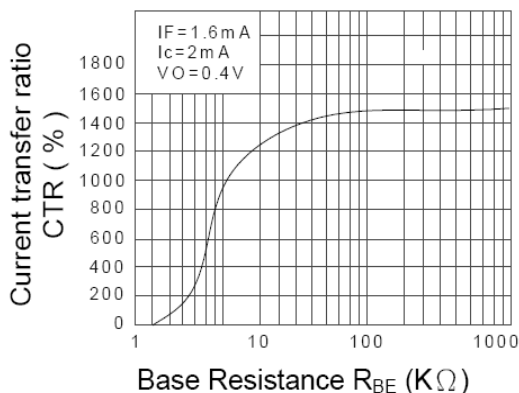
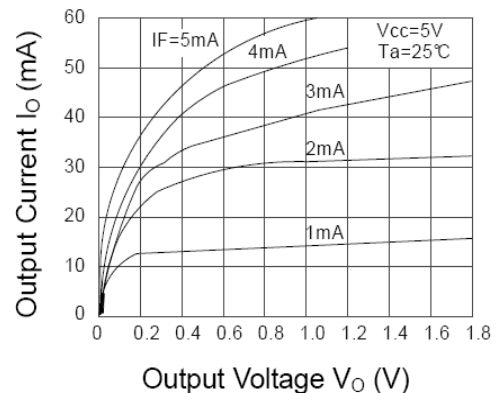

Fig.6 Output Current vs. Output Voltage



OPTEK reserves the right to make changes at any time in order to improve design and to supply the best product possible.

OPIA800

Fig.7 Output Current vs. Input Diode Forward Current

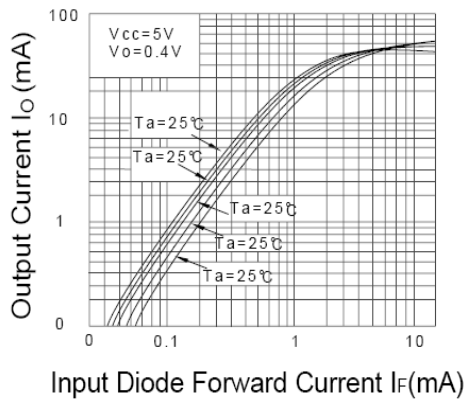

Fig.8 Logic Low Supply Current vs. Input Diode Forward Current

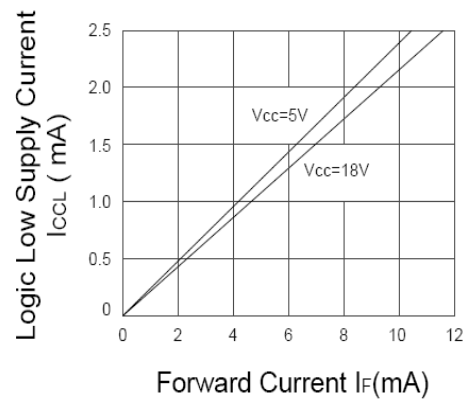

Fig.9 Propagation Delay vs. Input Diode Forward Current

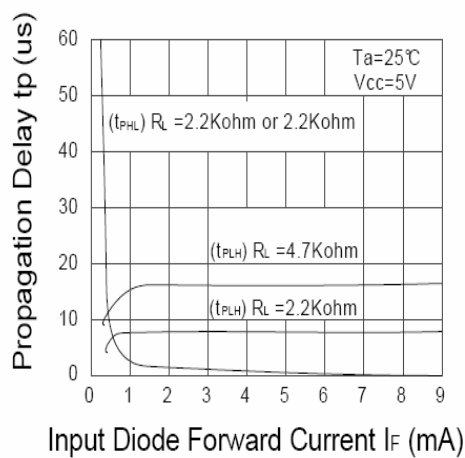
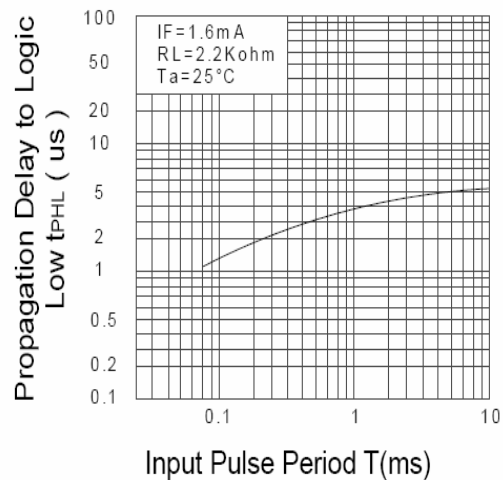

Fig.10 Propagation Delay to Logic Low vs. Pulse Period



OPTEK reserves the right to make changes at any time in order to improve design and to supply the best product possible.

OPID804

Fig.1 Low Level Output Voltage vs. Ambient Temperature

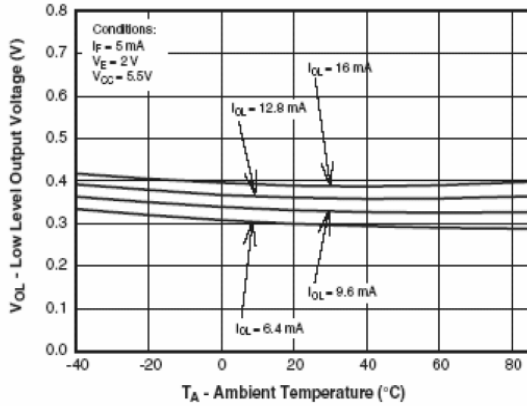

Fig.2 Input Diode Forward Voltage vs. Forward Current

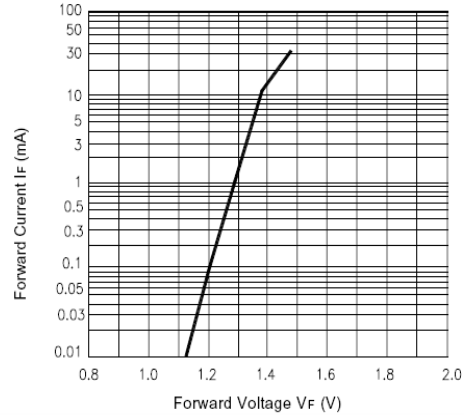

Fig.3 Switching Time vs. Forward Current

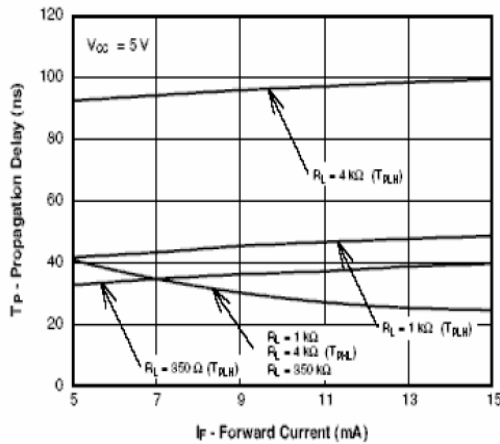

Fig.4 Low Level Output Current vs. Ambient Temperature

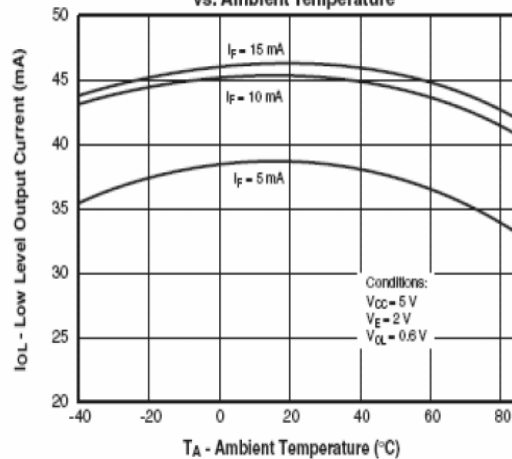

Fig.5 Input Threshold Current vs. Ambient Temperature

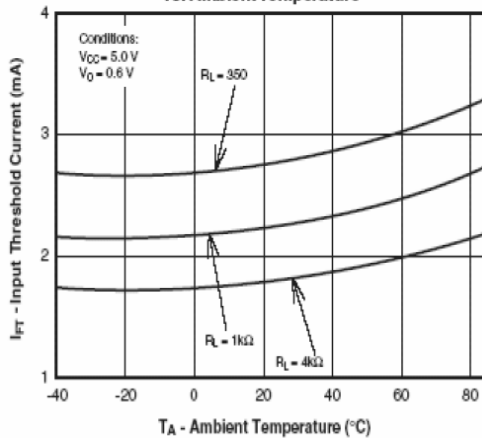
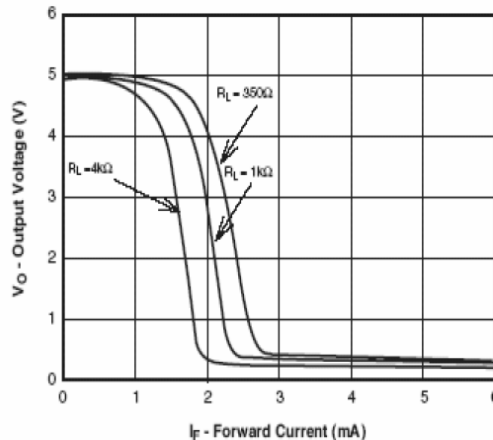

Fig.6 Output Voltage vs. Input Forward Current



OPTEK reserves the right to make changes at any time in order to improve design and to supply the best product possible.

OPID804

Fig. 11 High Level Output Current vs. Temperature

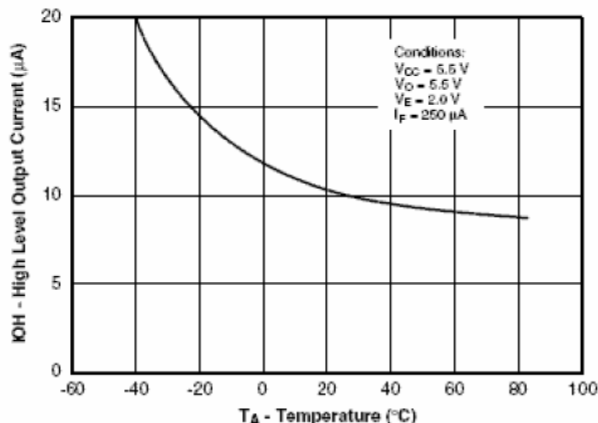

Fig. 9 Enable Propagation Delay vs. Temperature

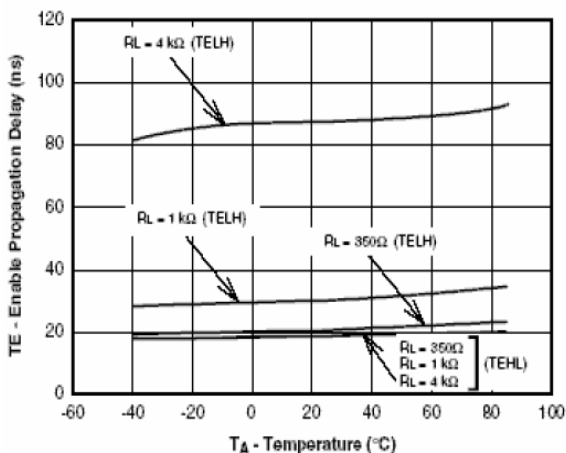

Fig. 10 Switching Time vs. Temperature

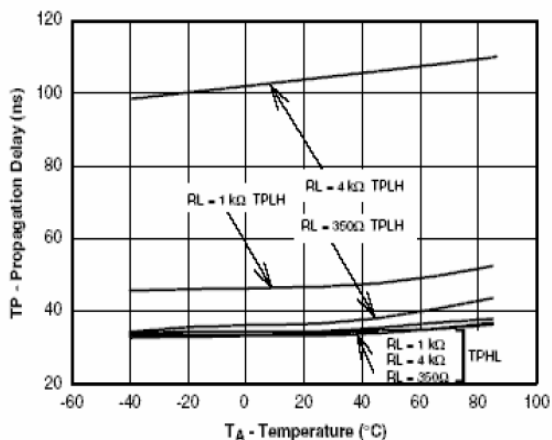

Fig. 7 Pulse Width Distortion vs. Temperature

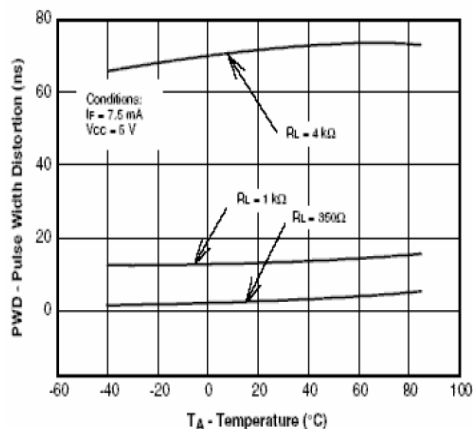
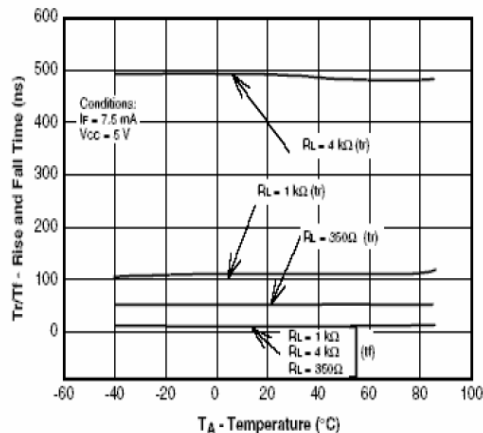

Fig. 8 Rise and Fall Time vs. Temperature



OPTEK reserves the right to make changes at any time in order to improve design and to supply the best product possible.

Optocoupler—DIP Package

OPIA800 through OPID804



Quality / Reliability Requirements

Parameter	Failure Criteria	Conditions
HTRB D I _{C(OFF)}	± 10%	11 samples after 500Hrs
	0 Fail	@ VCE = 5.0VDC, Ta = 70°C
HTFB D I _{C(ON)}	± 10%	50 samples after 96Hrs
	0 Fail	@ Max P _D , Ta = 25°C
MTTF @ 90% confidence	150,000 Min.	@ 25°C, 25mADC
Moisture Sensitivity Level	MSL 1	per JDEC std J-STD-020B
Lead Solderability	0 Fail	per Method 208 of MIL-STD-202.
Glass Transition of body	125°C Min.	DSC test method
Temperature Humidity-Bias	± 20%	85°C, 85%RH, 500Hrs, 80% min I _{ceo}
Temperature Cycle	± 20%	per Method 1010.7 of MIL-STD-883E
High Temperature Storage	± 20%	85°C, 500Hrs
Autoclave	0 Fail	T _A = 121°C, Pressure = 15psi, Humidity = 100%, Time = 96Hrs

Note: This is to be performed when a change occurs to form, fit or function.

Government and Industry Standard Compliance Requirements

European Union's Reduction of Hazardous Substances (RoHS) Directive 2002/95/EC

Label Identification:

DESCRIPTION:

Size: 3" (7.4 cm) X 2.2" (5.5 cm)
 Lettering shall be black on white background.
 Format shall be as:

Notes:

- The DATE CODE is a 4-digit code for date of manufacture where YY is the last two digits of the year, and WW is week number of manufacture.
- The LOT I.D. is the manufacturing location lot identification where Y is the year of manufacture, NNNN is a sequential lot identifier, and DDD is the day of the year of manufacture. – or use equivalent label format.

 Carrolton, TX, USA MADE IN TAIWAN
OPTEK P/N <u> OPIA800D-TU </u>
QTY. <u> N/A </u>
DATE CODE <u> (Y Y W W) </u>
LOT I.D. <u> (Y - N N N N D D D) </u>

OPTEK reserves the right to make changes at any time in order to improve design and to supply the best product possible.

Optocoupler—DIP Package

OPIA800 through OPID804



Packaging Information:

Optek's Optocoupler Part Numbers		Packaging Quantities		Tube		Inner			Small Carton			Medium Carton			Large Carton		
				Qty	Weight	52 x 7 x 7.5 cm		53.5 x 16 x 17.5 cm			53.5 x 30.7 x 17.5 cm			53.5 x 30.7 x 25 cm			
						Qty	Weight	Qty	Weight	Gross Weight	Qty	Weight	Gross Weight	Qty	Weight	Gross Weight	
P/H and SMD	4-PIN OPIA400D/A, OPIA410D/A - OPIA413D/A	100	44	3,000	1.40	12,000	6.0	6.5	24,000	12.0	12.5	36,000	18.0	18.5			
	6-PIN OPIA6XXD/A Series	65	44	1,950	1.50	7,800	6.5	7.0	15,600	12.0	12.5	23,400	18.5	19.0			
	8-PIN OPIA8XXD Series and OPID804D	48	44	1,440	1.44	5,760	6.0	6.5	11,520	12.0	12.5	17,290	18.0	18.5			
M/F SOP	4-PIN and 5-PIN OPIA401B - OPIA404B, OPIA414B, OPIA500B	100	24	6,000	1.60	24,000	6.5	7.0	48,000	13.0	13.5	72,000	19.5	20.0			
SSOP	4-PIN OPIA405C - OPIA409C	170	--	10,200	--												

P/H = Pin-Hole Packages (Referred as D = Dual-In-Line Package)

SMD = Standard Surface Mount Packages (Referred as A = 6.5mil SMD)

M/F or SOP = Mini-Flat Packages or Small Outside Packages (Referred as B = 4.40mil SMD w/ 2.54mil Lead-Spacing)

SSOP = Shrink SOP Packages (Referred as C = 3.60mil SMD with 1.27mil Lead-Spacing)

Tube Packaging Specifications (TU):

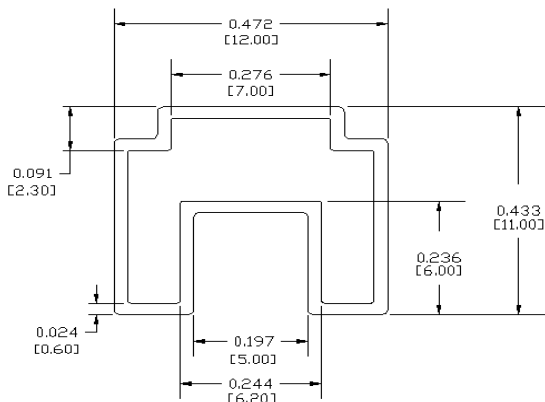

DIMENSIONS ARE IN: INCHES

TOLERANCE: ± 0.008 INCHES

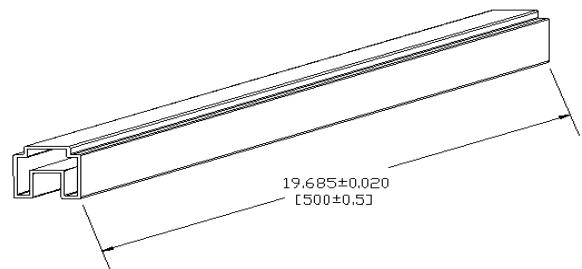

Quantity: 8-pin: 48pcs/tube

OPTEK reserves the right to make changes at any time in order to improve design and to supply the best product possible.