

**Optocoupler with Phototransistor Output**

**Description**

The TCET1600/ TCET2600/ TCET4600 consist of a phototransistor optically coupled to 2 gallium arsenide infrared-emitting diodes in a 4-lead up to 16-lead plastic dual inline package.

The elements are mounted on one leadframe using a coplanar technique, providing a fixed distance between input and output for highest safety requirements.

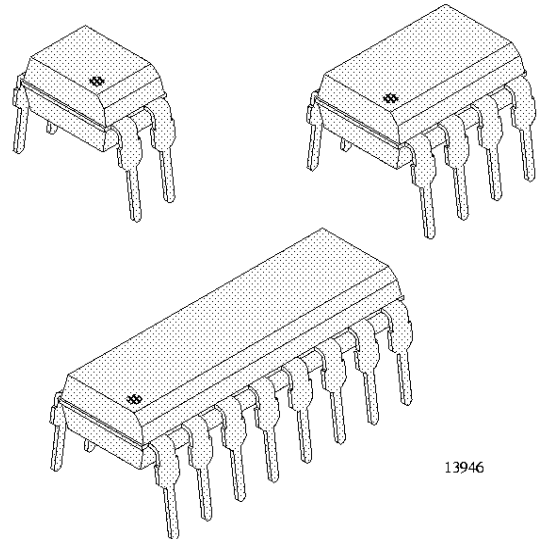

**Applications**

Circuits for safe protective separation against electrical shock according to safety class II (reinforced isolation):

- For application class I – IV at mains voltage ≤ 300 V
- For application class I – III at mains voltage ≤ 600 V according to VDE 0884, table 2, suitable for:

**Switch-mode power supplies, computer peripheral interface, microprocessor system interface, line receiver, telecom equipment.**

These couplers perform safety functions according to the following equipment standards:

- |  |  |
|--|--|
| <ul style="list-style-type: none"> <li>• <b>VDE 0884</b><br/>Optocoupler providing protective separation</li> <li>• <b>VDE 0805/IEC 950/EN 60950</b><br/>Office machines (applied for reinforced isolation for mains voltage ≤ 400 V<sub>RMS</sub>)</li> </ul> | <ul style="list-style-type: none"> <li>• <b>VDE 0804</b><br/>Telecommunication apparatus and data processing</li> <li>• <b>VDE 0860/IEC 65</b><br/>Safety for mains-operated electronic and related household apparatus</li> </ul> |
|--|--|

**Pin Connection**

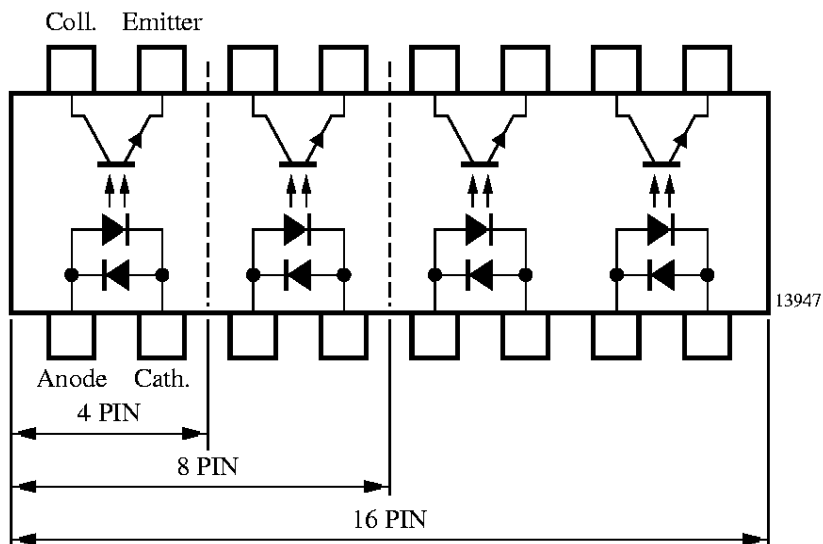

## Features

- Approvals:  
BSI: BS EN 41003, BS EN 60065 (BS 415)  
BS EN 60950 (BS 7002)  
Certificate No. 7081 and 7402  
FIMKO (SETI): EN 60950  
Certificate No. 41400  
Underwriters Laboratory (UL) 1577  
recognized-file No. E-76222  
VDE 0884 Certificate number 101348

VDE 0884 related features:

- Rated impulse voltage (transient overvoltage)  
 $V_{IOTM} = 6 \text{ kV peak}$
- Isolation test voltage (partial discharge test voltage)  
 $V_{pd} = 1.6 \text{ kV}$
- Rated isolation voltage (RMS includes DC)  
 $V_{IOWM} = 600 \text{ V}_{RMS} (848 \text{ V peak})$

- Rated recurring peak voltage (repetitive)  
 $V_{IORM} = 600 \text{ V}_{RMS}$
- Creepage current resistance according to  
VDE 0303/IEC 112  
Comparative Tracking Index:  $CTI \geq 200$
- Thickness through insulation  $\geq 0.75 \text{ mm}$

General features:

- Isolation materials according to UL94-VO
- Pollution degree 2 (DIN/VDE 0110 / resp. IEC 664)
- Climatic classification 55/100/21 (IEC 68 part 1)
- Special construction:  
Therefore extra low coupling capacity of typical  
0.2 pF, high Common Mode Rejection
- Low temperature coefficient of CTR
- Coupling System U

## Order Instruction

Part Numbers	CTR Ranking
TCET1600 / TCET2600 / TCET4600	> 20%

**Absolute Maximum Ratings**

**Input (Emitter)**

Parameters	Test Conditions	Symbol	Value	Unit
Reverse voltage		$V_R$	6	V
Forward current		$I_F$	±60	mA
Forward surge current	$t_p \leq 10 \mu s$	$I_{FSM}$	±1.5	A
Power dissipation	$T_{amb} \leq 25^\circ C$	$P_V$	100	mW
Junction temperature		$T_j$	125	°C

**Output (Detector)**

Parameters	Test Conditions	Symbol	Value	Unit
Collector emitter voltage		$V_{CEO}$	70	V
Emitter collector voltage		$V_{ECO}$	7	V
Collector current		$I_C$	50	mA
Collector peak current	$t_p/T = 0.5, t_p \leq 10 ms$	$I_{CM}$	100	mA
Power dissipation	$T_{amb} \leq 25^\circ C$	$P_V$	150	mW
Junction temperature		$T_j$	125	°C

**Coupler**

Parameters	Test Conditions	Symbol	Value	Unit
Isolation test voltage (RMS)		$V_{IO}^{1)}$	3.75	kV
Total power dissipation	$T_{amb} \leq 25^\circ C$	$P_{tot}$	250	mW
Operating ambient temperature range		$T_{amb}$	-40 to +100	°C
Storage temperature range		$T_{stg}$	-55 to +125	°C
Soldering temperature	2 mm from case $t \leq 10 s$	$T_{sd}$	260	°C

1) Related to standard climate 23/50 DIN 50014

## Maximum Safety Ratings <sup>1)</sup> (according to VDE 0884)

### Input (Emitter)

Parameters	Test Conditions	Symbol	Value	Unit
Forward current		$I_{si}$	130	mA

### Output (Detector)

Parameters	Test Conditions	Symbol	Value	Unit
Power dissipation	$T_{amb} \leq 25^{\circ}C$	$P_{si}$	265	mW

### Coupler

Parameters	Test Conditions	Symbol	Value	Unit
Rated impulse voltage		$V_{IOTM}$	6	kV
Safety temperature		$T_{si}$	150	$^{\circ}C$

- 1) This device is used for protective separation against electrical shock only within the maximum safety ratings. This must be ensured by using protective circuits in the applications.

## Derating Diagram

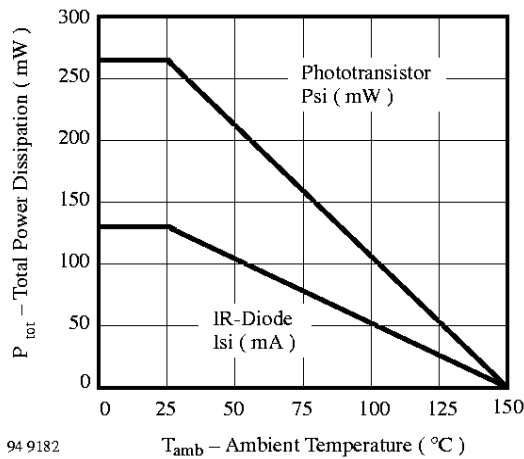

**Electrical Characteristics**  $T_{amb} = 25^{\circ}\text{C}$

**Input (Emitter)**

Parameters	Test Conditions	Symbol	Min.	Typ.	Max.	Unit
Forward voltage	$I_F = \pm 50 \text{ mA}$	$V_F$		1.25	1.6	V
Reverse current	$V_R = \pm 6 \text{ V}$	$I_R$			10	$\mu\text{A}$

**Output (Detector)**

Parameters	Test Conditions	Symbol	Min.	Typ.	Max.	Unit
Collector emitter voltage	$I_C = 100 \mu\text{A}$	$V_{CE0}$	70			V
Emitter collector voltage	$I_E = 100 \mu\text{A}$	$V_{EC0}$	7			V
Collector dark current	$V_{CE} = 20 \text{ V}, I_F = 0, E = 0$	$I_{CE0}$			100	nA

**Coupler**

Parameters	Test Conditions	Symbol	Min.	Typ.	Max.	Unit
Isolation test voltage (RMS)	$f = 50 \text{ Hz}, t = 1 \text{ s}$	$V_{IO}^{2)}$	3.75			V
Isolation resistance	$V_{IO} = 100 \text{ V},$ 40% rel. humidity	$R_{IO}^{2)}$	$10^{10}$	$10^{12}$		$\Omega$
$I_C/I_F$	$V_{CE} = 5 \text{ V}, I_F = \pm 5 \text{ mA}$	CTR	0.20		3.0	
Collector/emitter saturation voltage	$I_F \pm 10 \text{ mA}, I_C = 1 \text{ mA}$	$V_{CEsat}$			0.3	V
Cut off frequency	$V_{CE} = 5 \text{ V}, I_F \pm 10 \text{ mA},$ $R_L = 100 \Omega$	$f_c$		100		kHz
Coupling capacitance	$f = 1 \text{ MHz}$	$C_k$		0.3		pF

2) Related to standard climate 23/50 DIN 50014

## Switching Characteristics (Typical Values)

$V_S = 5\text{ V}$

Type	$R_L = 100\ \Omega$ (see figure 1)							$R_L = 1\text{ k}\Omega$ (see figure 2)		
	$t_d[\mu\text{s}]$	$t_r[\mu\text{s}]$	$t_{on}[\mu\text{s}]$	$t_s[\mu\text{s}]$	$t_f[\mu\text{s}]$	$t_{off}[\mu\text{s}]$	$I_C[\text{mA}]$	$t_{on}[\mu\text{s}]$	$t_{off}[\mu\text{s}]$	$I_F[\text{mA}]$
TCET1600/TCET2600/ TCET4600	3.0	3.0	6.0	0.3	4.7	5.0	2.0	9.0	18.0	10.0

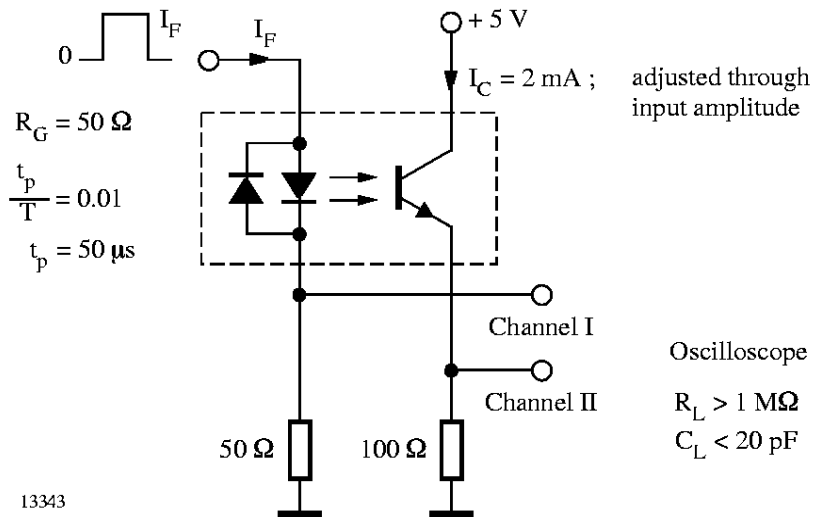

Figure 1. Test circuit

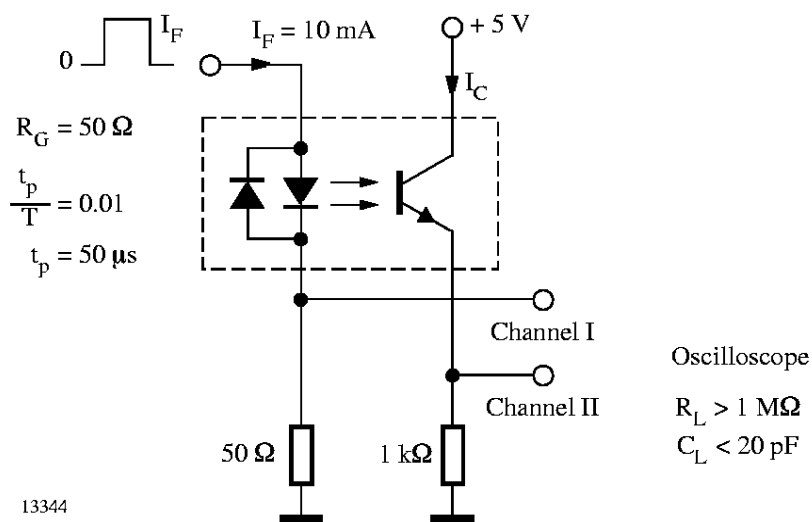

Figure 2. Test circuit, saturated operation

**Insulation Rated Parameters (according to VDE 0884)**

Parameters		Test Conditions	Symbol	Min.	Typ.	Max.	Unit
Partial discharge test voltage	Routine test	100%, $t_{test} = 1$ s	$V_{pd}$	1.6			kV
	Lot test (sample test)	$t_{Tr} = 60$ s, $t_{test} = 10$ s (see figure 3)	$V_{IOTM}$	6			kV
			$V_{pd}$	1.3			kV
Isolation resistance		$V_{IO} = 500$ V	$R_{IO}$	$10^{12}$			$\Omega$
		$V_{IO} = 500$ V, $T_{amb} = 100^{\circ}C$	$R_{IO}$	$10^{11}$			$\Omega$
		$V_{IO} = 500$ V, $T_{amb} = 150^{\circ}C$ (construction test only)	$R_{IO}$	$10^9$			$\Omega$

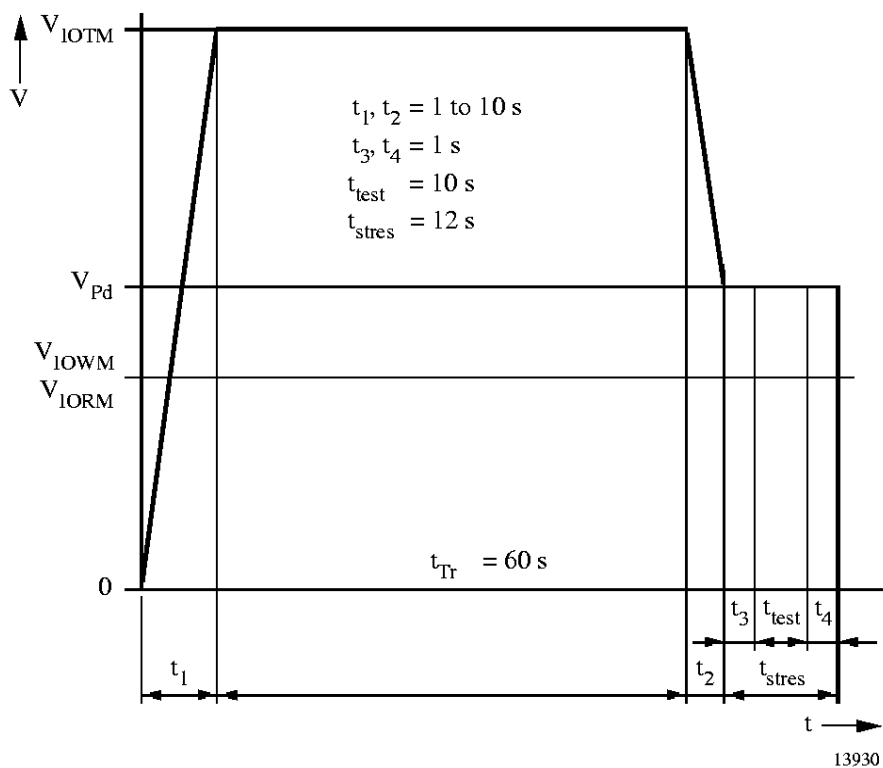

Figure 3. Test pulse diagram for sample test according to DIN VDE 0884

## Typical Characteristics ( $T_{amb} = 25^{\circ}\text{C}$ , unless otherwise specified)

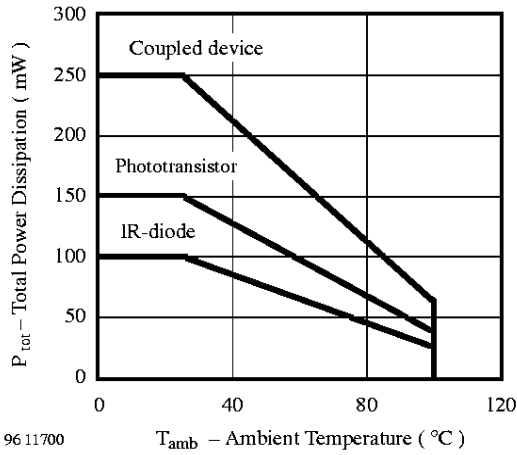

Figure 4. Total Power Dissipation vs. Ambient Temperature

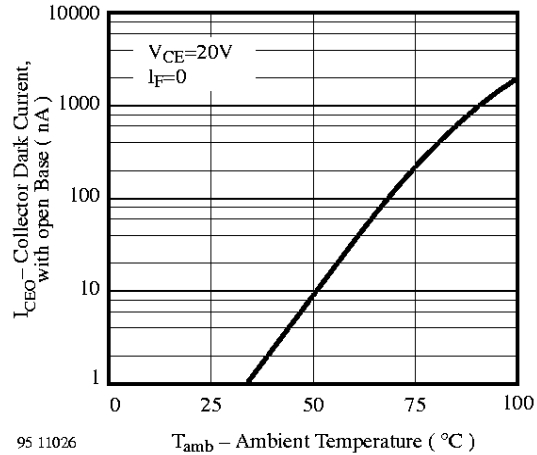

Figure 7. Collector Dark Current vs. Ambient Temperature

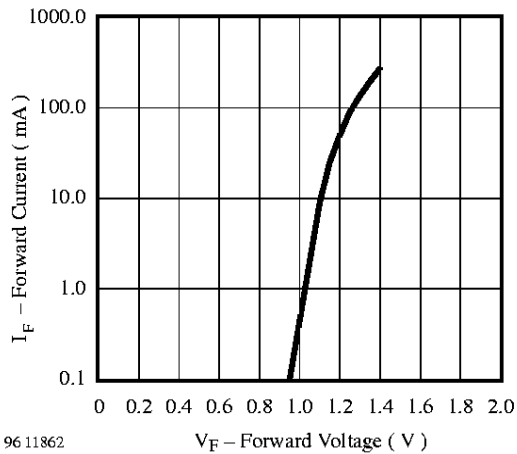

Figure 5. Forward Current vs. Forward Voltage

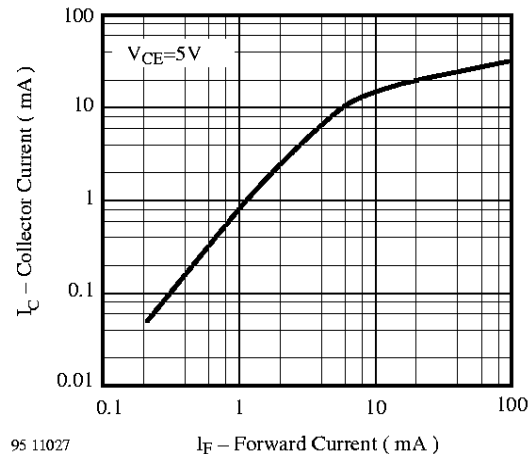

Figure 8. Collector Current vs. Forward Current

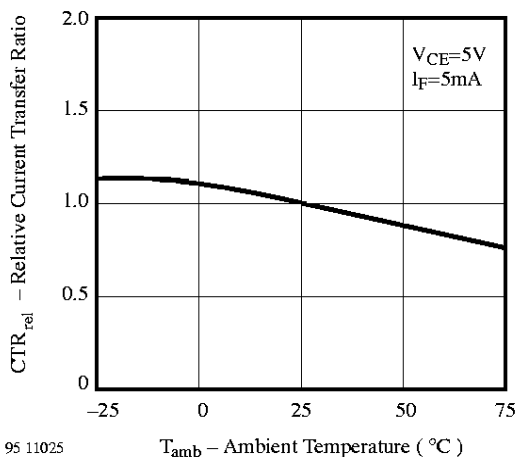

Figure 6. Rel. Current Transfer Ratio vs. Ambient Temperature

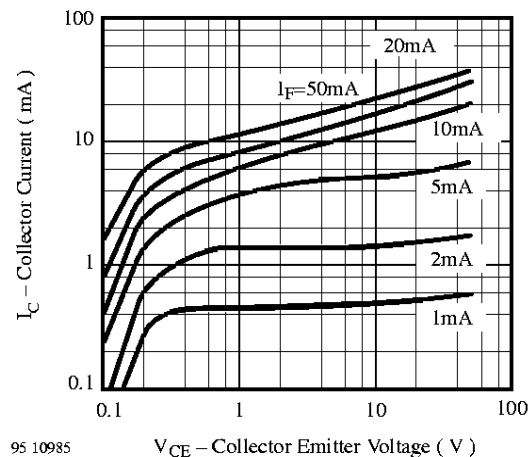

Figure 9. Collector Current vs. Collector Emitter Voltage

**Typical Characteristics** ( $T_{amb} = 25^{\circ}C$ , unless otherwise specified)

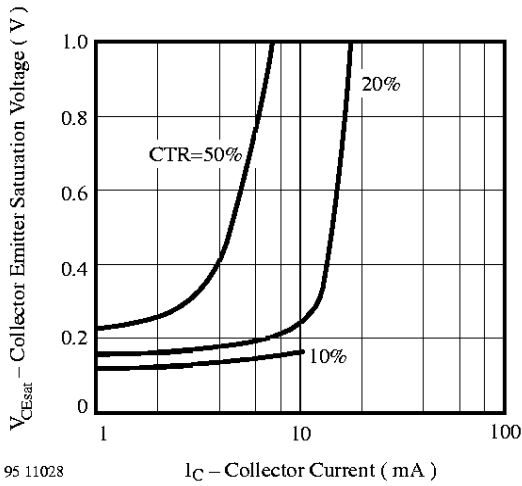

Figure 10. Collector Emitter Sat. Voltage vs. Collector Current

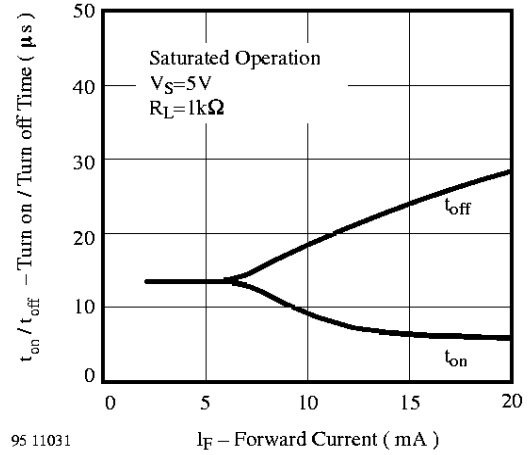

Figure 12. Turn on / off Time vs. Forward Current

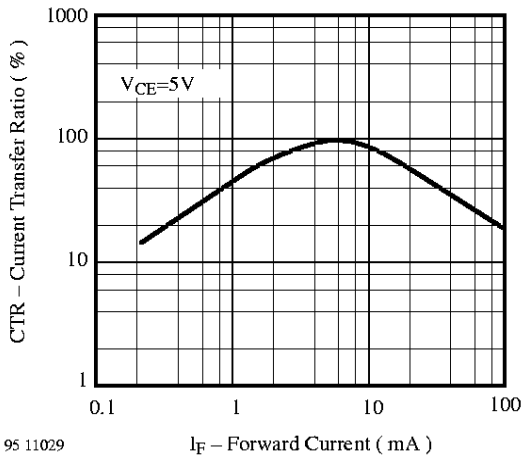

Figure 11. Current Transfer Ratio vs. Forward Current

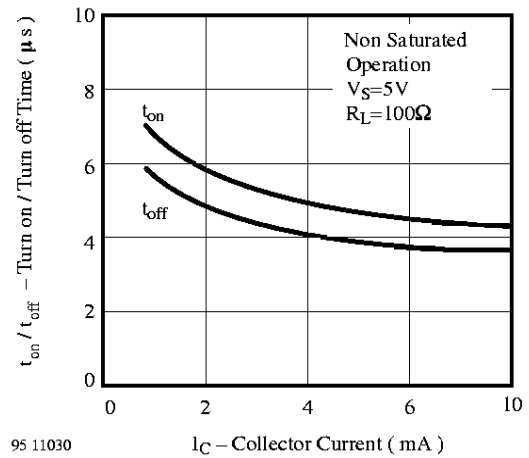
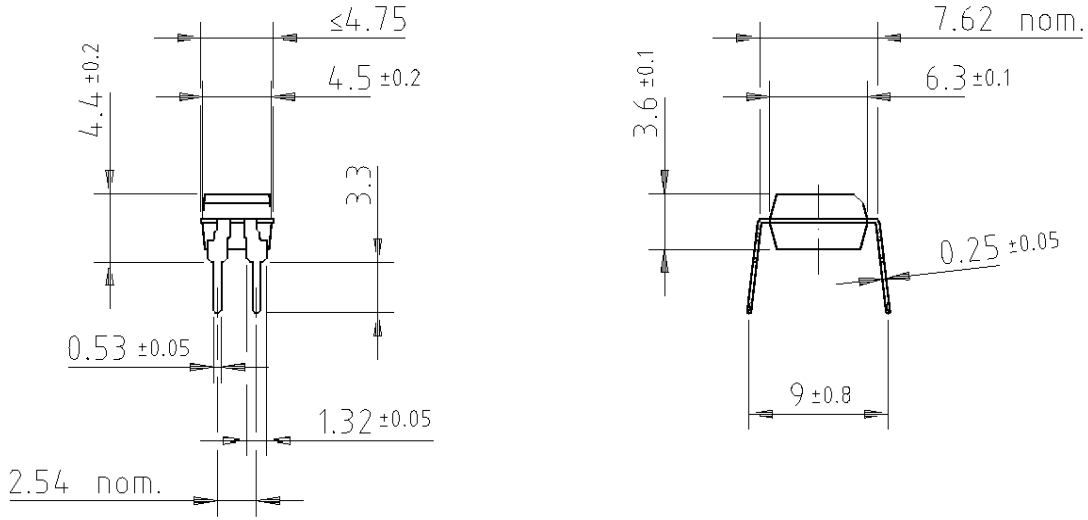

Figure 13. Turn on / off Time vs. Collector Current

# TCET1600 up to TCET4600

## Dimensions of TCET1600 in mm



E.g.:

special Features: endstackable  
to 2.54mm ( .100" ) spacing

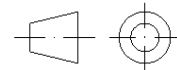
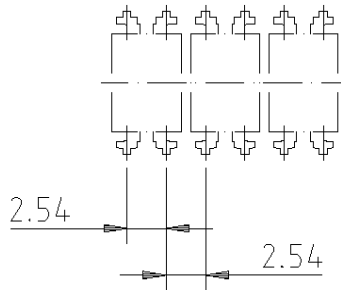
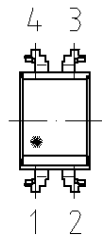

technical drawings  
according to DIN  
specifications

14789

weight: 0.25 g  
creeping distance:  $\cong 6 \text{ mm}$   
air path:  $\cong 6 \text{ mm}$

after mounting on PC board

**Dimensions of TCET2600 in mm**

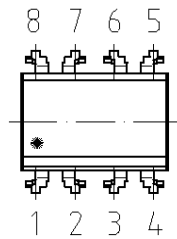
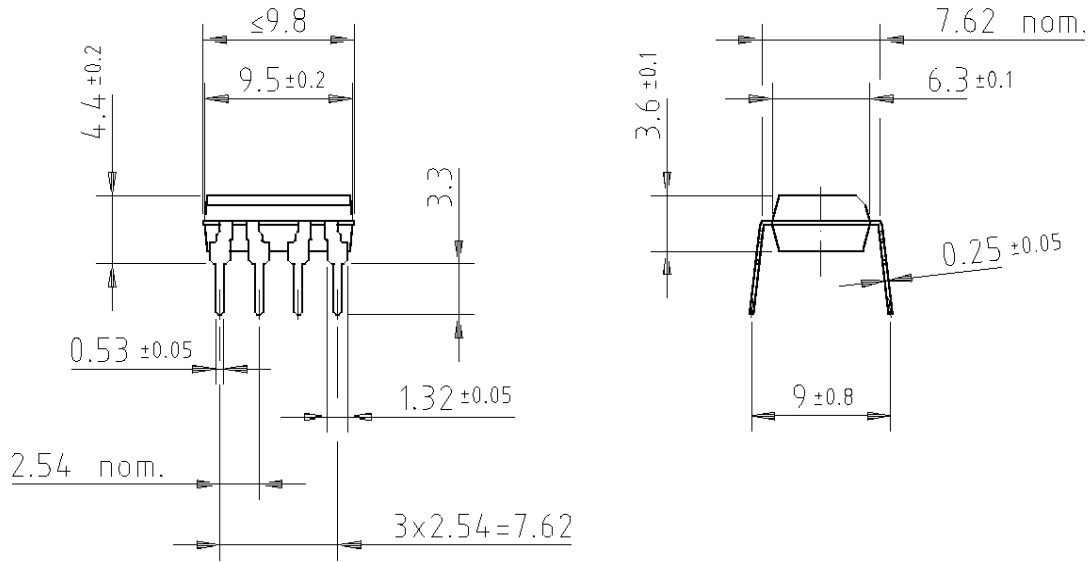

technical drawings  
according to DIN  
specifications

14784

weight: 0.5 g  
creeping distance:  $\cong 6$  mm  
air path:  $\cong 6$  mm

after mounting on PC board

# TCET1600 up to TCET4600

## Dimensions of TCET4600 in mm

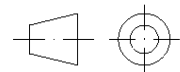
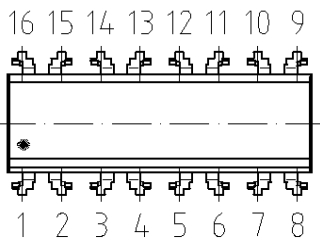
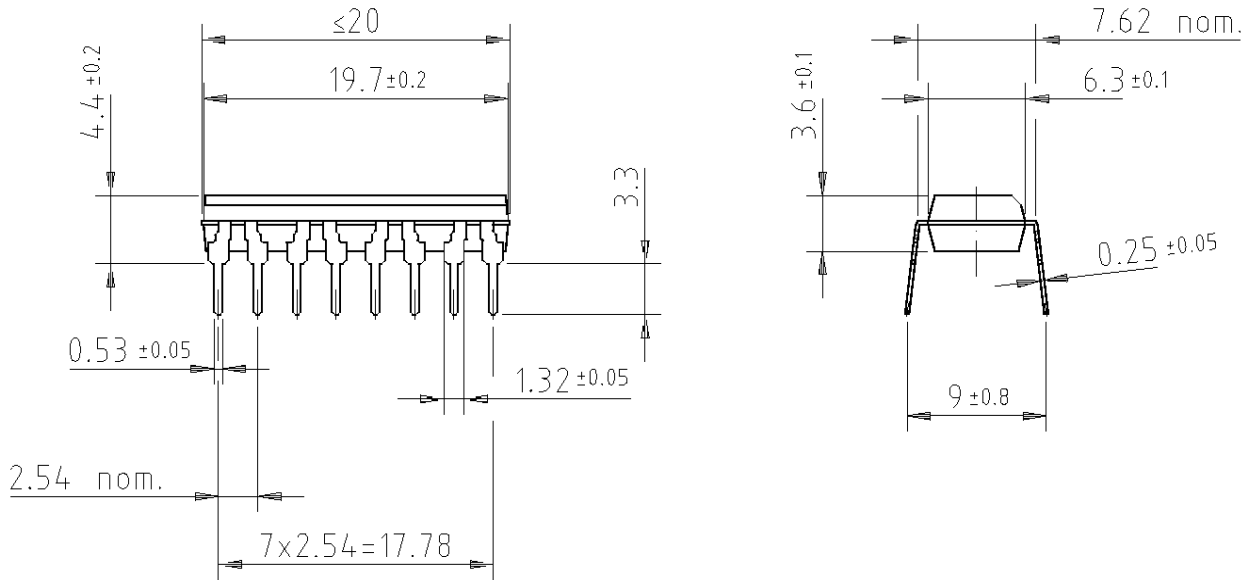

14783

technical drawings  
according to DIN  
specifications

weight: 1.0 g  
creeping distance:  $\geq 6$  mm  
air path:  $\geq 6$  mm

after mounting on PC board

## Ozone Depleting Substances Policy Statement

It is the policy of **TEMIC TELEFUNKEN microelectronic GmbH** to

1. Meet all present and future national and international statutory requirements.
2. Regularly and continuously improve the performance of our products, processes, distribution and operating systems with respect to their impact on the health and safety of our employees and the public, as well as their impact on the environment.

It is particular concern to control or eliminate releases of those substances into the atmosphere which are known as ozone depleting substances (ODSs).

The Montreal Protocol (1987) and its London Amendments (1990) intend to severely restrict the use of ODSs and forbid their use within the next ten years. Various national and international initiatives are pressing for an earlier ban on these substances.

**TEMIC TELEFUNKEN microelectronic GmbH** semiconductor division has been able to use its policy of continuous improvements to eliminate the use of ODSs listed in the following documents.

1. Annex A, B and list of transitional substances of the Montreal Protocol and the London Amendments respectively
2. Class I and II ozone depleting substances in the Clean Air Act Amendments of 1990 by the Environmental Protection Agency (EPA) in the USA
3. Council Decision 88/540/EEC and 91/690/EEC Annex A, B and C (transitional substances) respectively.

**TEMIC** can certify that our semiconductors are not manufactured with ozone depleting substances and do not contain such substances.

**We reserve the right to make changes to improve technical design and may do so without further notice.**

Parameters can vary in different applications. All operating parameters must be validated for each customer application by the customer. Should the buyer use **TEMIC** products for any unintended or unauthorized application, the buyer shall indemnify **TEMIC** against all claims, costs, damages, and expenses, arising out of, directly or indirectly, any claim of personal damage, injury or death associated with such unintended or unauthorized use.

TEMIC TELEFUNKEN microelectronic GmbH, P.O.B. 3535, D-74025 Heilbronn, Germany  
Telephone: 49 (0)7131 67 2831, Fax number: 49 (0)7131 67 2423