

NJL1121L

1

■ Features

- High-output high-speed infrared emitting device using GaAlAs(Si)
- High response speed equivalent to about 2 times that of conventional products.

■ Absolute Maximum Ratings (Ta=25°C)

Forward Current (Continuous)	I_F	100mA
Pulse Forward Current	I_{FP}	1A (note 1)
Reverse Voltage (Continuous)	V_R	6V
Power Dissipation	P_D	170mW
Operating Temperature	T_{opr}	-20°C to +90°C
Storage Temperature	T_{stg}	-30°C to +100°C
Leads Soldering Temperature	T_{sol}	260°C (note 2)

(note 1) Pulse Width: 100 μ s, Duty Ratio: 0.01

(note 2) 10sec, 1.5mm from body

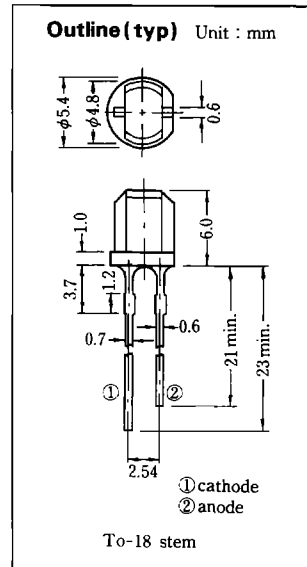

■ Electro-Optical Characteristics (Ta=25°C)

Parameter	Symbol	Test Condition	Min.	Typ.	Max.	Unit
Radiant Power	ϕ_e	$I_F=50mA$	—	7	—	mW
Spectral Line Halfwidth	$\Delta\lambda$	$I_F=50mA$	—	75	—	nm
Forward Voltage	V_f	$I_F=50mA$	—	1.28	—	V
Reverse Current	I_R	$V_R=6V$	—	—	1	μ A
Capacitance	Ct	$V_R=0V, f=1MHz$	—	25	—	pF
Fall Time	t_f	$I_F=50mA$	—	500	—	ns
Rise Time	t_r	$I_F=50mA$	—	500	—	ns
Peak Wavelength	λ_p	$I_F=50mA$	—	900	—	nm

■ Typical Characteristics

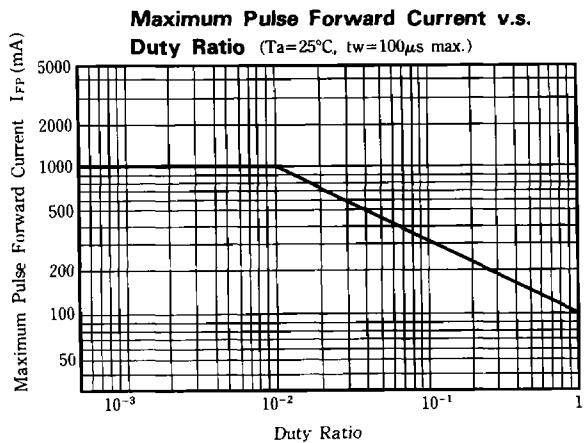
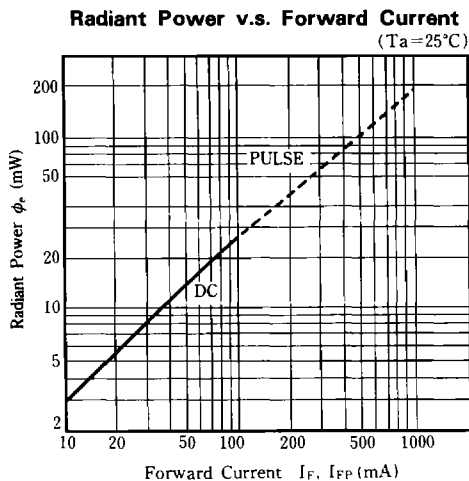

Maximum Pulse Width v.s. Forward Current
($T_a=25^\circ\text{C}$, Duty Ratio 0.01 max.)

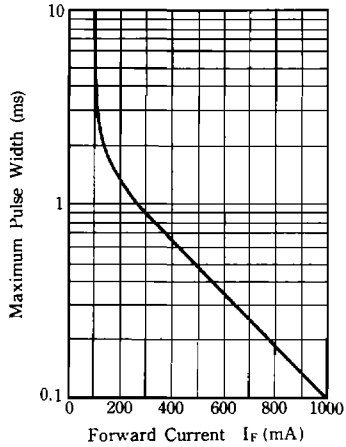

Forward Voltage v.s. Temperature

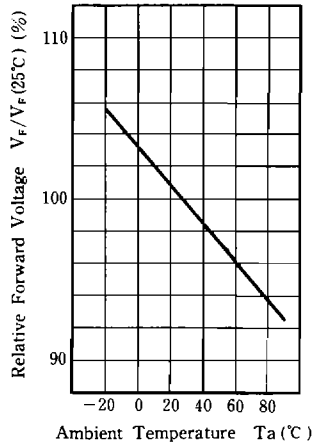

Forward Current v.s. Forward Voltage ($T_a=25^\circ\text{C}$)

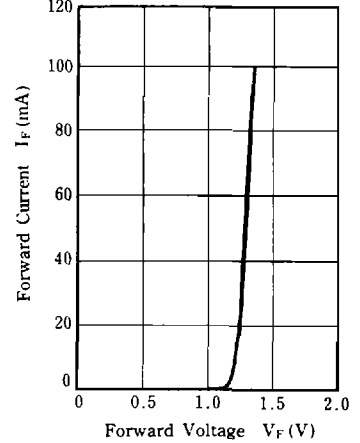

Power Dissipation v.s. Temperature

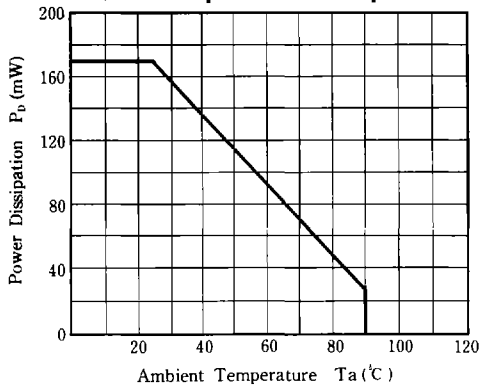

Relative Radiant Power v.s. Temperature

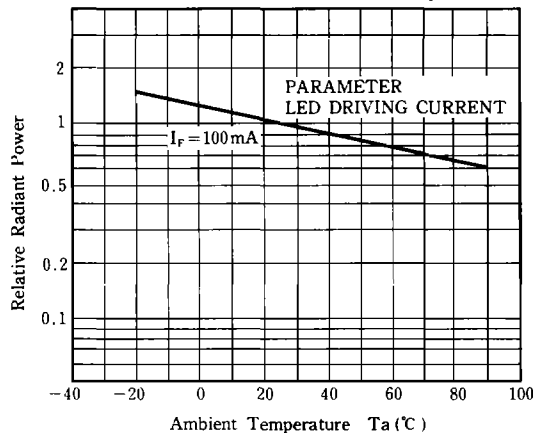

Typical Radiation Pattern
($T_a=25^\circ\text{C}$)

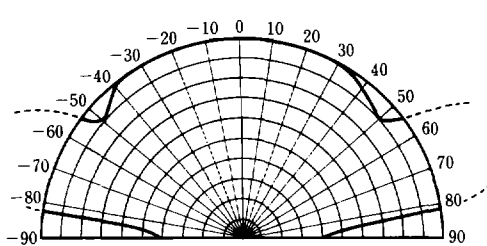

Relative Intensity v.s. Wavelength
($T_a=25^\circ\text{C}$)

