

RMMS2410-10

2.4 GHz GaAs MMIC PA/LNA/Switch

Package Data

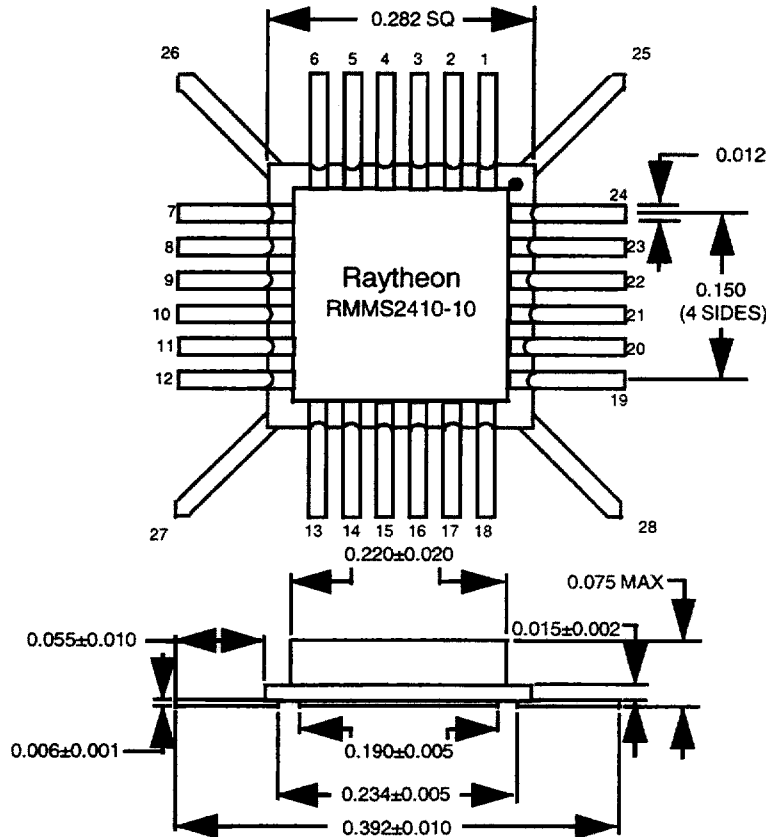

Lead #	Description
1	N/C
2	PAVd 2
3	N/C
4	N/C
5	TR_
6	TR
7	N/C
8	N/C
9	T/R COM
10	LOGIC Vd
11	N/C
12	AD_
13	AD
14	A1
15	GRN
16	ANT COM
17	GRN
18	A2
19	LNA Vd
20	N/C
21	RCV
22	TX IN
23	PA VG
24	PAVd1
25	GRN
26	GRN
27	GRN
28	GRN

Advanced Information

Functional Block Diagram

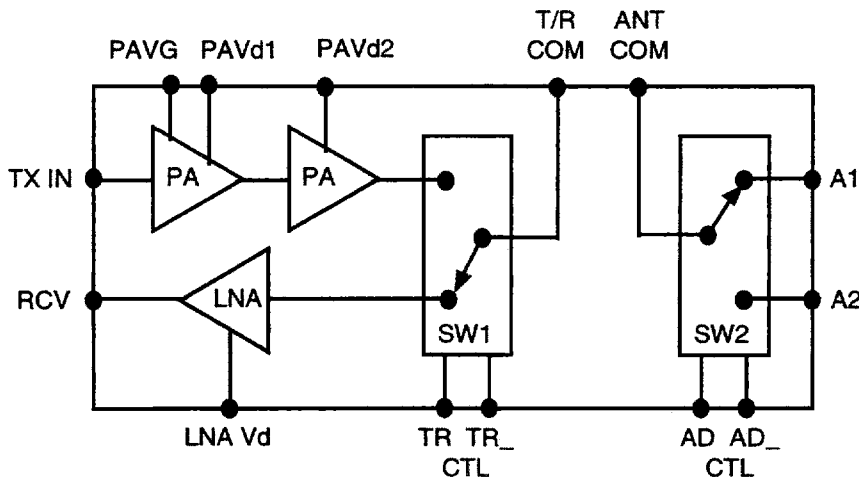

SW1 LOGIC		
LEAD #	5	6
TX IN	1	0
RCV	0	1

SW2 LOGIC		
LEAD #	12	13
A1	1	0
A2	0	1

This is advanced information which contains data on products in development. Characteristic performance data and specifications are subject to change without notice.

RMMS2410-10

2.4 GHz GaAs MMIC PA/LNA/Switch

Advanced Information

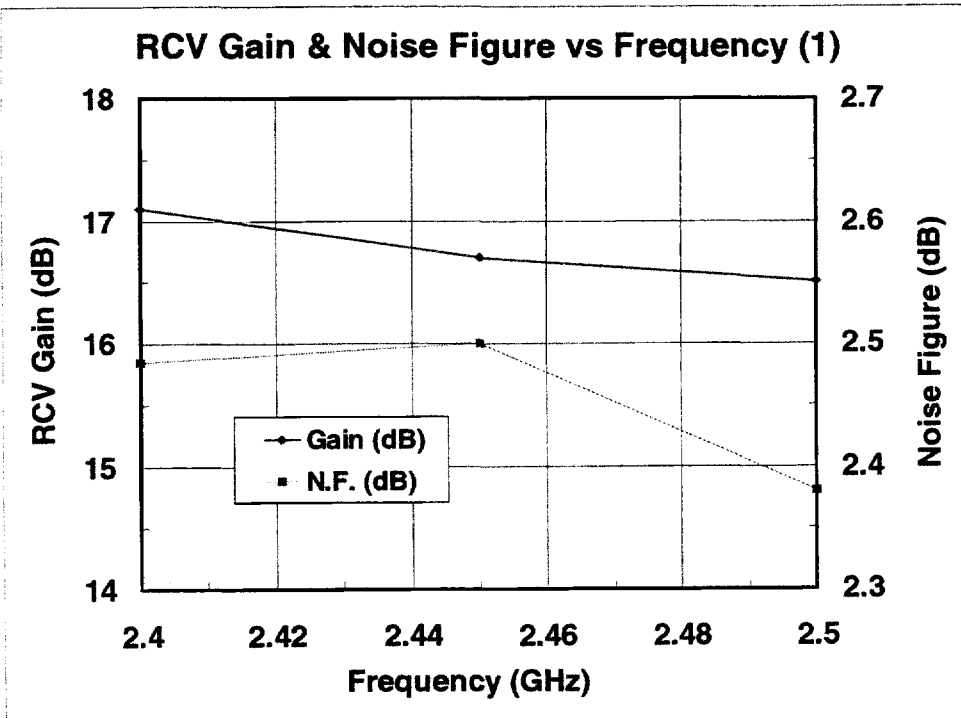
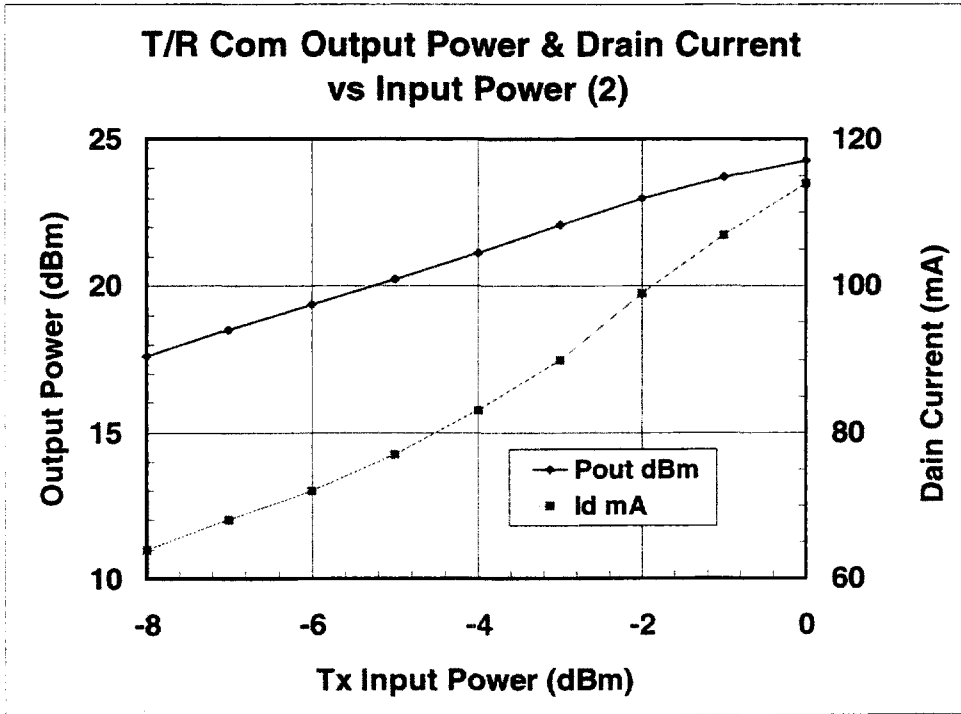

This is advanced information which contains data on products in development. Characteristic performance data and specifications are subject to change without notice.

RMMS2410-10

2.4 GHz GaAs MMIC PA/LNA/Switch

Advanced Information

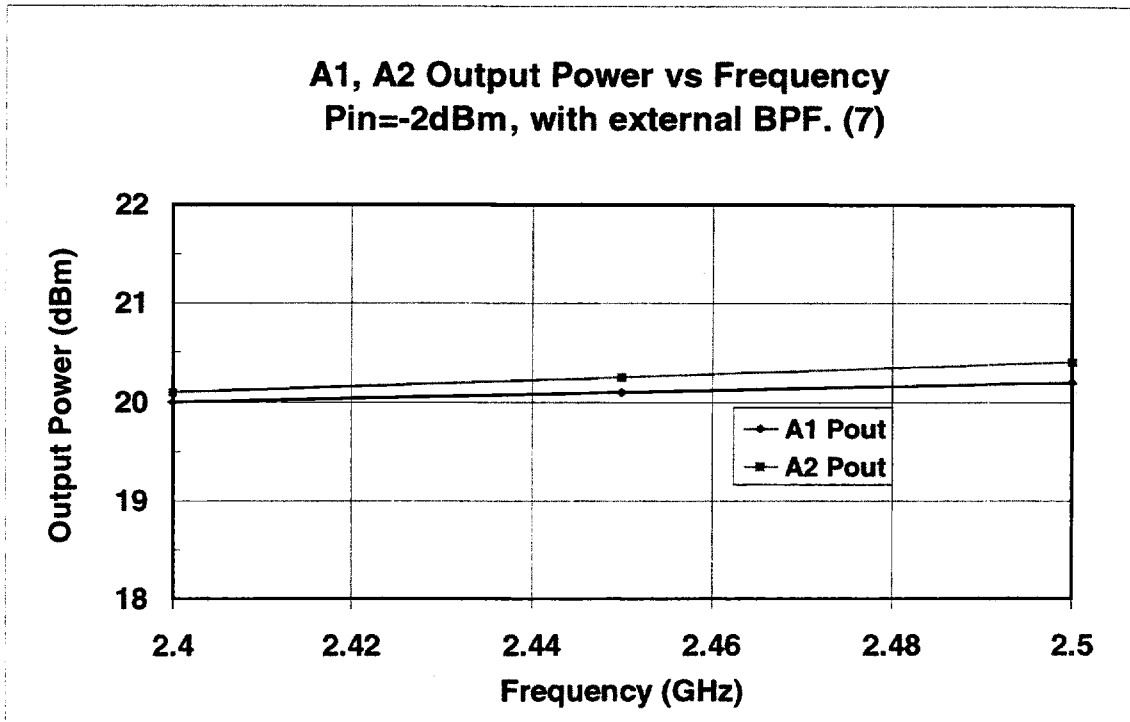
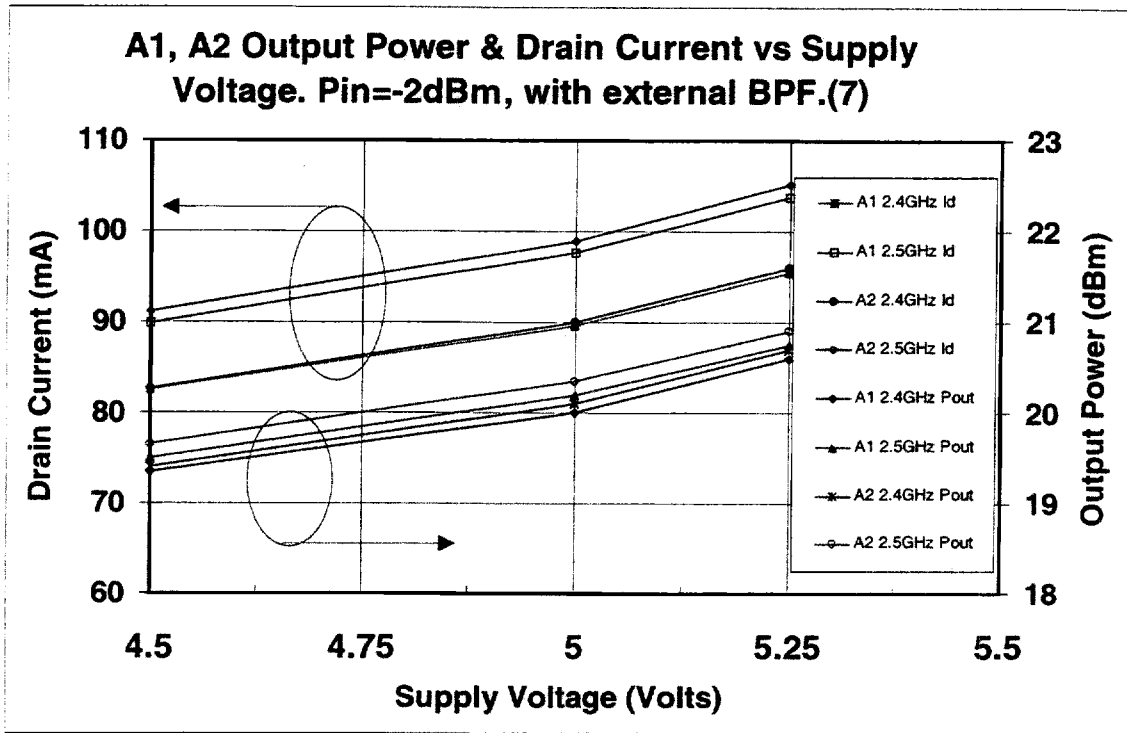

This is advanced information which contains data on products in development. Characteristic performance data and specifications are subject to change without notice.