MSM7540/7560

Single Rail ADPCM CODEC

GENERAL DESCRIPTION

The MSM7540/7560 are single channel ADPCM CODEC ICs which perform mutual transcoding between an analog voice band signal 300 to 3400 Hz and 32 kbps ADPCM serial data.

Using advanced circuit technology, these devices operate using a single 5 V power supply and have low power consumption.

The MSM7540/7560 are optimized for advanced digital cordless telephone system applications.

FEATURES

- Single 5 V Power Supply Operation
- ADPCM Algorithm : Complies completely with 1988's version ITU-T G.721 (32 kbps)
- Transmit/Receive Full-Duplex Operation
- Transmit/Receive Synchronous Mode Only
- Serial ADPCM Transmission Data Rate : 32 kbps to 2048 kbps
- Serial PCM Transmission Data Rate : 64 kbps to 2048 kbps
- PCM Interface Coding Format
 - MSM7540 : A-law or Linear (14-bit, 2's compliment) Selectable
 - MSM7560 : μ-law or Linear (14-bit, 2's compliment) Selectable
- Low Power Consumption
 - Operating Mode : 60 mW Typ.
 - Power-Down Mode : 1.0 mW Typ.
- Two Analog Input Amplifier Stages : Externally Adjustable Gain
- Analog Output Stage : Push-pull Drive (direct drive of 350 Ω + 120 nF)
- Built-in Crystal Oscillator (10.368 MHz)
- Built-in Reference Voltage Supply
- Option Reset Specified by ITU-T G. 721/ADPCM
- Package:
 - 28-pin plastic SOP (SOP28-P-430-1.27-K) (Product name: MSM7540GS-K)
 - (Product name: MSM7560GS-K)

BLOCK DIAGRAM

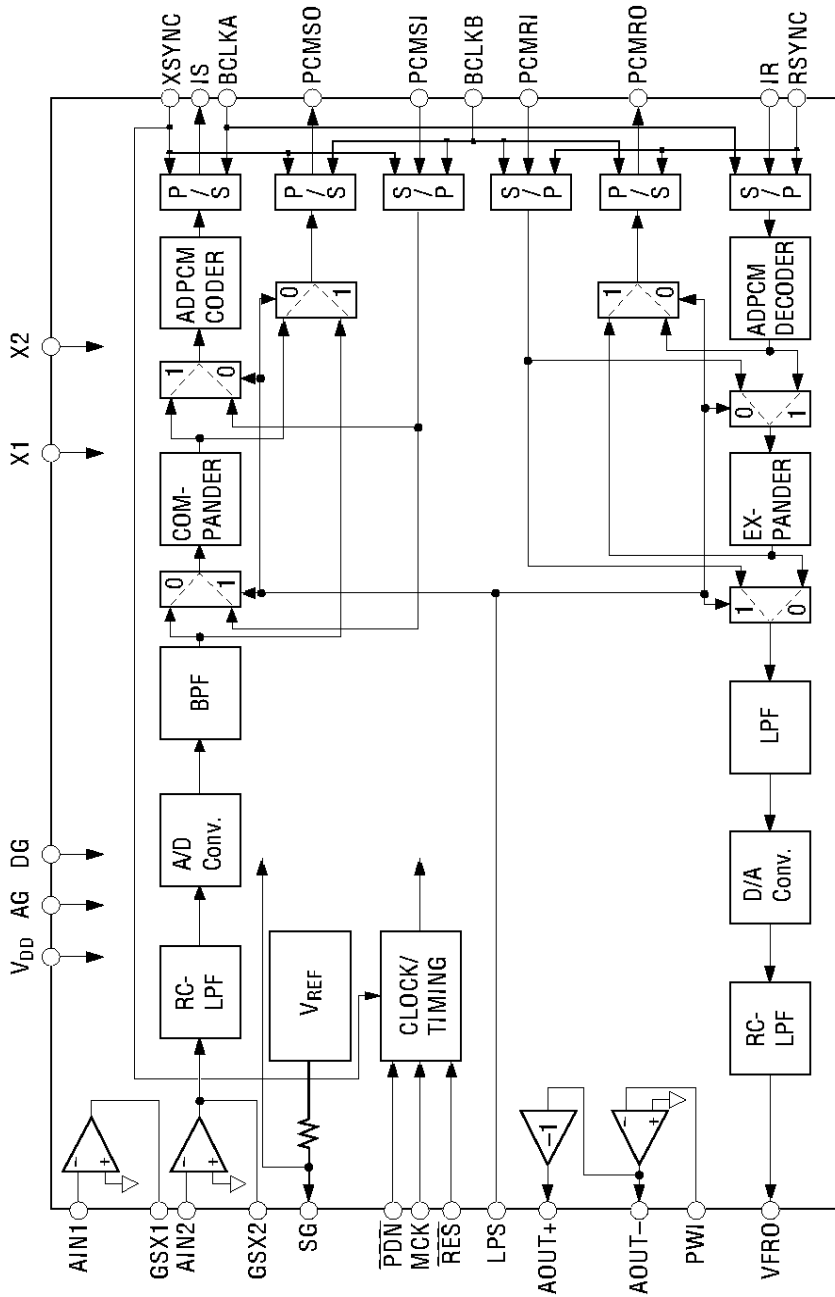

PIN CONFIGURATION (TOP VIEW)

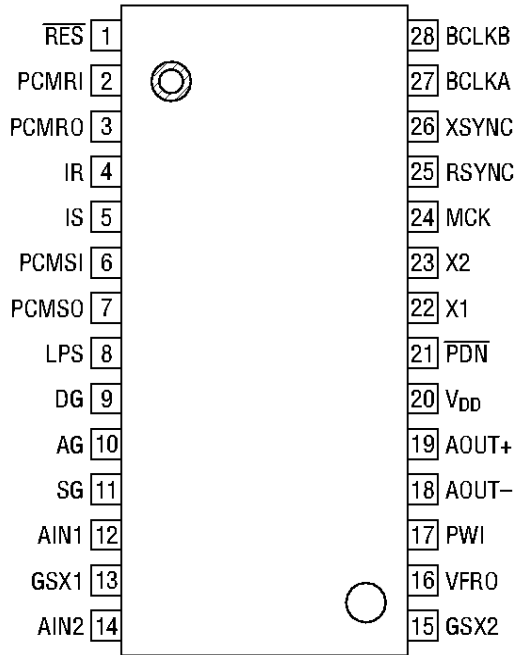

28-Pin Plastic SOP

PIN AND FUNCTIONAL DESCRIPTIONS

AIN1, AIN2, GSX1, GSX2

Transmit analog inputs and the output for transmit gain adjustment. AIN1 (AIN2) connects to the inverting input of the internal transmit amplifier. GSX1 (GSX2) connects to the internal transmit amplifier output. Refer to Fig. 1 for gain adjustment.

VFRO, AOUT+, AOUT-, PWI

Receive analog output and the output for receive gain adjustment. VFRO is the receive filter output. AOUT+ and AOUT- are differential analog signal outputs which can directly drive $Z_L = 350 \Omega + 120 \text{ nF}$. Refer to Fig. 1 for gain adjustment.

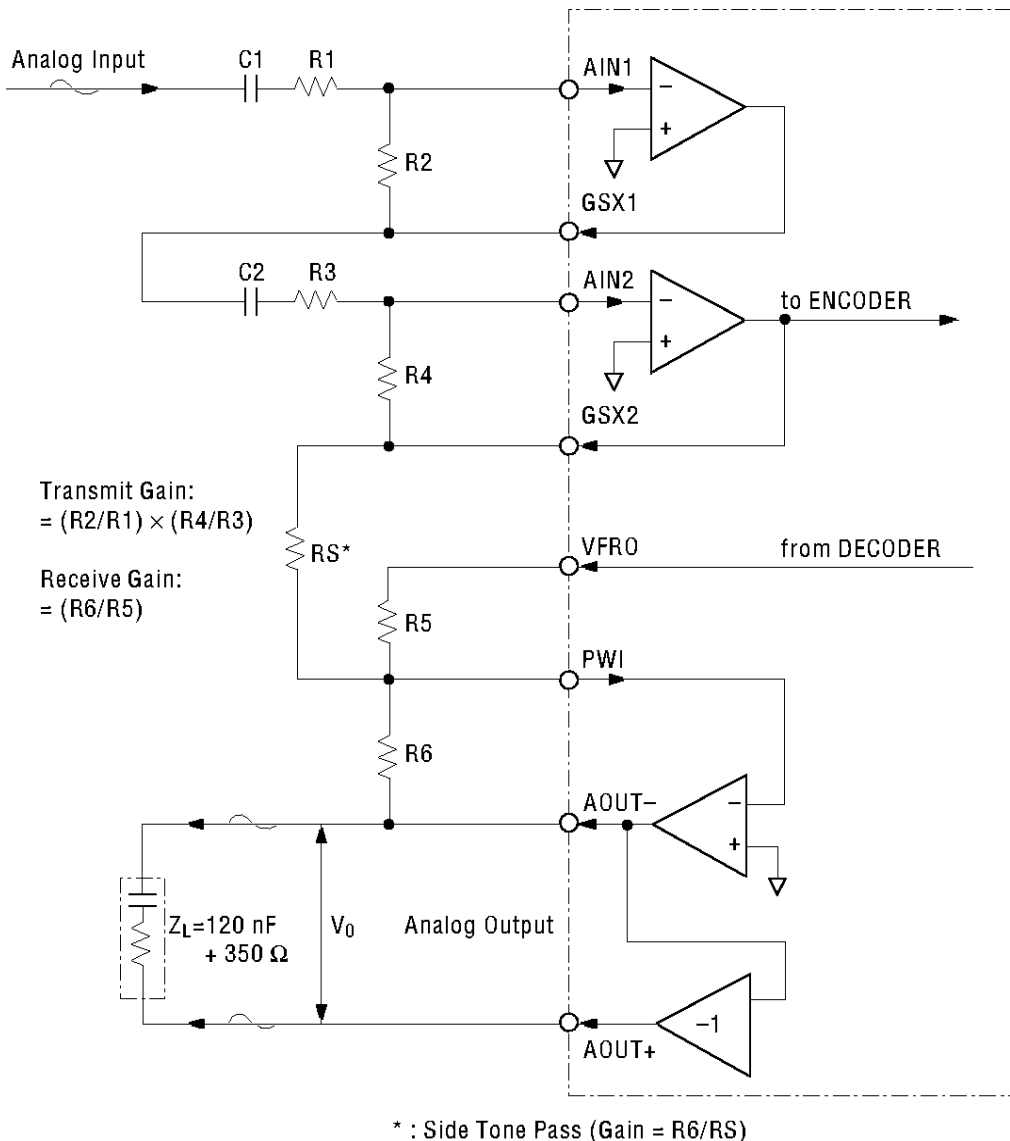

Figure 1 Analog Input/Output Interface

SG

Analog signal ground voltage output.

The output voltage of this pin is approximately 2.4 V. Put bypass capacitors between this pin and the AG pin. During power-down this output voltage is 0 V. The external SG voltage, if necessary, should be used via a buffer.

AG

Analog ground.

DG

Digital ground.

This ground is separated internally from the analog signal ground pin (AG). The DG pin must be kept as close as possible to AG on the PCB.

V_{DD}

+5 V power supply.

LPS

PCM coding law selection.

MSM7540 only ; if this pin goes to a "0" level, PCMSO, PCMSI, PCMRO, and PCMRI become the A-law character signal, and if these pins goes to a "1" level, the signal becomes a linear value character signal (2's complement).

MSM7560 only ; if this pin goes to a "0" level, PCMSO, PCMSI, PCMRO, and PCMRI become the μ -law character signal, and if these pins goes to a "1" level, the signal becomes a linear value character signal (2's complement).

 $\overline{\text{PDN}}$

Power down control input.

If this pin is "0", this device is in the power-down state.

Normally, this pin is set to "1".

 $\overline{\text{RES}}$

Optional reset input specified by ITU-T Recommendation G. 721.

If this pin is "0", the device is in the reset state. The reset width (during "L") should be 125 μ s or more.

MCK

Master clock input.

The frequency must be 10.368 MHz. The master clock signal may be asynchronous to BCLKA, BCLKB, XSYNC, and RSYNC.

PCMSO

Transmit PCM data output.

PCM is output from MSB in synchronization with the rising edge of BCLKB and XSYNC.

PCMSI

Transmit PCM data input.

This signal is converted to the transmit ADPCM data. PCM is shifted in synchronization with the falling edge of BCLKB. Normally, this pin is connected to PCMSO.

PCMRO

Receive PCM data output.

PCM is the output signal after ADPCM decoder processing. This signal is output serially from MSB in synchronization with the rising edge of BCLKB and RSYNC.

PCMRI

Receive PCM data input.

PCM is shifted on the falling edge of the BCLKB and input from MSB. Normally, this pin is connected to PCMRO.

IS

Transmit ADPCM signal output.

After having encoded PCM with ADPCM, this signal is output from MSB in synchronization with the rising edge of BCLKA and XSYNC. This pin is an open drain output and remains in a high impedance state during power-down. IS requires a pull-up resistor.

IR

Receive ADPCM signal input.

The ADPCM signal is shifted in series and synchronization with the falling edge of BCLKA and RSYNC, starting with MSB.

BCLKB

Shift clock input for the PCM data (PCMSO, PCMSI, PCMRO, PCMRI).

The frequency is set in the 64 kHz to 2048 kHz range.

XSYNC

8 kHz synchronous signal input for transmit PCM and ADPCM data.

Synchronize this signal with BCLKA and BCLKB signal. XSYNC is used to indicate the MSB of the serial PCM and ADPCM data stream.

Be sure to input the XSYNC signal because it is also used as the input of the timing generator.

RSYNC

8 kHz synchronous signal input for receive PCM and ADPCM data.

Synchronize this signal with BCLKA and BCLKB signal. RSYNC is used to indicate the MSB of the serial PCM and ADPCM data stream.

BCLKA

Shift clock input for the ADPCM data (IS, IR).

The frequency is set in the range of 32 kHz to 2048 kHz.

X1, X2

Crystal oscillator (10.368 MHz) connection.

Connect X2, the clock output pin, directly to the MCK pin.

When using a conventional external clock of 10.368 MHz, X1 should be connected to the ground, leave X2 open, and provide the external clock through the MCK pin.

<Using a self-oscillation circuit>

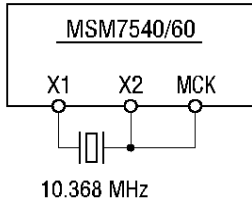

<Using an external clock>

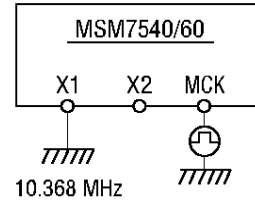

ABSOLUTE MAXIMUM RATINGS

Parameter	Symbol	Condition	Rating	Unit
Power Supply Voltage	V _{DD}	—	-0.3 to +7	V
Analog Input Voltage	V _{AIN}	—	-0.3 to V _{DD} + 0.3	V
Digital Input Voltage	V _{DIN}	—	-0.3 to V _{DD} + 0.3	V
Storage Temperature	T _{STG}	—	-55 to +150	°C

RECOMMENDED OPERATING CONDITIONS

Parameter	Symbol	Condition	Min.	Typ.	Max.	Unit
Power Supply Voltage	V _{DD}	Voltage must be fixed	4.5	—	5.5	V
Operating Temperature	T _a	—	-25	+25	+70	°C
Input High Voltage	V _{IH}	MCK, XSYNC, RSYNC, PCMRI, PCMSI, BCLKA, BCLKB, IR, LPS, PDN, RES	2.2	—	V _{DD}	V
Input Low Voltage	V _{IL}	MCK, XSYNC, RSYNC, PCMRI, PCMSI, BCLKA, BCLKB, IR, LPS, PDN, RES	0	—	0.6	V
Master Clock Frequency	f _{MCK}	MCK	-0.01%	10.368	+0.01%	MHz
Bit Clock Frequency	f _{BCKA}	BCLKA	32	—	2048	kHz
	f _{BCKB}	BCLKB	64	—	2048	kHz
Synchronous Signal Frequency	f _{SYMC}	XSYNC, RSYNC	—	8.0	—	kHz
Clock Duty Ratio	D _C	MCK, BCLKA, BCLKB	30	50	70	%
Digital Input Rise Time	t _{ir}	MCK, XSYNC, RSYNC, PCMRI, PCMSI, BCLKA, BCLKB, IR, LPS, PDN, RES	—	—	50	ns
Digital Input Fall Time	t _{if}	MCK, XSYNC, RSYNC, PCMRI, PCMSI, BCLKA, BCLKB, IR, LPS, PDN, RES	—	—	50	ns
Transmit Sync Signal Setting Time	t _{XS}	BCLKA, BCLKB to XSYNC	100	—	—	ns
	t _{XS}	XSYNC to BCLKA, BCLKB	100	—	—	ns
Receive Sync Signal Setting Time	t _{RS}	BCLKA, BCLKB to RSYNC	100	—	—	ns
	t _{SR}	RSYNC to BCLKA, BCLKB	100	—	—	ns
Synchronous Signal Width	t _{WS}	XSYNC, RSYNC	1 BCLK	—	100	μs
PCM, ADPCM Set-up Time	t _{DS}	—	100	—	—	ns
PCM, ADPCM Hold Time	t _{DH}	—	100	—	—	ns
Digital Output Load	R _{DL}	IS (Pull-up Resistor)	500	—	—	Ω
	C _{DL}	IS, PCMSO, PCMRO	—	—	100	pF
Bypass Capacitor for SG	C _{SG}	SG↔GND	—	10 + 0.1	—	μF

ELECTRICAL CHARACTERISTICS

DC and Digital Interface Characteristics

($V_{DD} = 4.5\text{ V to }5.5\text{ V}$, $T_a = -25^\circ\text{C to }+70^\circ\text{C}$)

Parameter	Symbol	Condition	Min.	Typ.	Max.	Unit
Power Supply Current	I_{DD1}	Operating Mode, (When no signal, and $V_{DD} = 5.0\text{ V}$)	—	12	24	mA
	I_{DD2}	Power Down Mode (When $V_{DD} = 5.0\text{ V}$)	—	0.2	0.5	mA
Input High Voltage	V_{IH}	—	2.2	—	V_{DD}	V
Input Low Voltage	V_{IL}	—	0.0	—	0.6	V
Input Leakage Current	I_{IH}	$V_I = V_{DD}$	—	—	2.0	μA
	I_{IL}	$V_I = 0\text{ V}$	—	—	0.5	μA
Output Low Voltage	V_{OL}	1 LSTTL, Pull-up: $500\ \Omega$	0.0	0.2	0.4	V
Output Leakage Current	I_O	IS	—	—	10	μA
Input Capacitance	C_{IN}	—	—	5	—	pF

Transmit Analog Interface Characteristics

Parameter	Symbol	Condition	Min.	Typ.	Max.	Unit
Input Resistance	R_{INX}	AIN1, AIN2	10	—	—	$\text{M}\Omega$
Output Load Resistance	R_{LGX}	GSX1, GSX2	50	—	—	$\text{k}\Omega$
Output Load Capacitance	C_{LGX}	GSX1, GSX2	—	—	100	pF
Output Amplitude	V_{OGX}	GSX1, GSX2, $R_L = 50\ \text{k}\Omega$	—	—	*2.226	V_{PP}
Input Offset Voltage	V_{OFGX}	Pre-OPAMPs	-20	—	+20	mV
SG Output Voltage	V_{SG}	—	—	1.4	—	V
SG Output Impedance	R_{SG}	—	—	40	80	$\text{k}\Omega$
SG Rise Time	T_{SG}	SG \leftrightarrow GND $10\ \mu\text{F} + 0.1\ \mu\text{F}$ (Rise time to 90% of max. level)	—	700	—	ms

* $-3\ \text{dBm}$ ($600\ \Omega$) = $0\ \text{dBm}_0$, $+3.14\ \text{dBm}_0 = 2.226\ V_{PP}$ (MSM7540)

$-3\ \text{dBm}$ ($600\ \Omega$) = $0\ \text{dBm}_0$, $+3.17\ \text{dBm}_0 = 2.226\ V_{PP}$ (MSM7560)

Receive Analog Interface Characteristics

Parameter	Symbol	Condition	Min.	Typ.	Max.	Unit	
Input Resistance	R _{INPW}	PWI	10	—	—	MΩ	
Output Load Resistance	R _{LVF}	VFRO	50	—	—	kΩ	
	R _{LAO}	AOUT+, AOUT-	1.2	—	—	kΩ	
Output Capacitance	C _{LVF}	VFRO	—	—	100	pF	
	C _{LAO}	AOUT+, AOUT-	—	—	100	pF	
Output Voltage Level	V _{OVF}	VFRO R _L = 50 kΩ	—	—	*2.226	V _{PP}	
	V _{OAO}	AOUT+, AOUT- Z _L = 350 Ω + 120 nF(See Fig.1)	R _L = 1.2 kΩ	—	—	*2.226	V _{PP}
			Z _L = 350 Ω + 120 nF(See Fig.1)	—	—	*2.226	V _{PP}
Offset Voltage	V _{OVVF}	VFRO	-100	—	+100	mV	
	V _{OFAO}	AOUT+, AOUT- (GAIN = 0 dB), Power amp only	-20	—	+20	mV	
Open Loop Gain	G _{DB}	Power amp (0.3 to 3.4 kHz, Z _L = 350 Ω + 120 nF)(See Fig.1)	40	—	—	dB	

* -3 dBm (600 Ω) = 0 dBm0, + 3.14 dBm0 = 2.226 V_{PP} (MSM7540)
 -3 dBm (600 Ω) = 0 dBm0, + 3.17 dBm0 = 2.226 V_{PP} (MSM7560)

AC Characteristics

(V_{DD} = 4.5 V to 5.5 V, T_a = -25°C to +70°C)

Parameter	Symbol	Condition			Min.	Typ.	Max.	Unit
		Freq. (Hz)	Level (dBm0)	Others				
Transmit Frequency Response	L _{oss} T1	0 to 60	0	—	25	—	—	dB
	L _{oss} T2	300 to 3000			-0.15	—	+0.20	dB
	L _{oss} T3	1020			Reference			dB
	L _{oss} T4	3300			-0.15	—	+0.80	dB
	L _{oss} T5	3400			0	—	0.80	dB
	L _{oss} T6	3968.75			14	—	—	dB
Receive Frequency Response	L _{oss} R1	0 to 3000	0	—	-0.15	—	+0.20	dB
	L _{oss} R2	1020			Reference			dB
	L _{oss} R3	3300			-0.15	—	+0.80	dB
	L _{oss} R4	3400			0	—	0.80	dB
	L _{oss} R5	3968.75			14	—	—	dB
Transmit Signal to Distortion Ratio	SD T1	1020	3	(*1)	35	—	—	dB
	SD T2		0		35	—	—	dB
	SD T3		-30		35	—	—	dB
	SD T4		-40		28	—	—	dB
	SD T5		-45		23	—	—	dB
Receive Signal to Distortion Ratio	SD R1	1020	3	(*1)	35	—	—	dB
	SD R2		0		35	—	—	dB
	SD R3		-30		35	—	—	dB
	SD R4		-40		28	—	—	dB
	SD R5		-45		23	—	—	dB
Transmit Gain Tracking	GT T1	1020	3	—	-0.2	—	+0.2	dB
	GT T2		-10		Reference			dB
	GT T3		-40		-0.2	—	+0.2	dB
	GT T4		-50		-0.5	—	+0.5	dB
	GT T5		-55		-1.2	—	+1.2	dB
Receive Gain Tracking	GT R1	1020	3	—	-0.2	—	+0.2	dB
	GT R2		-10		Reference			dB
	GT R3		-40		-0.2	—	+0.2	dB
	GT R4		-50		-0.5	—	+0.5	dB
	GT R5		-55		-1.2	—	+1.2	dB

*1 Use the P-message weighted filter

AC Characteristics (Continued)

(V_{DD} = 4.5 V to 5.5 V, T_a = -25°C to +70°C)

Parameter	Symbol	Condition			Min.	Typ.	Max.	Unit
		Freq. (Hz)	Level (dBm0)	Others				
Idle Channel Noise	N _{IDLT}	—	A _{IN} = SG	(*1)	—	—	-69 (-72)	dBm0p (dBmp)
	N _{IDLR}	—	—	(*1) (*2)	—	—	-72 (-75)	
Absolute Signal Amplitude	A _{VT}	1020	0	GSX2	0.488	0.548 (*3)	0.615	V _{rms}
	A _{VR}			VFR0	0.488	0.548 (*3)	0.615	V _{rms}
Power Supply Noise Rejection Ratio	P _{SRRT}	Noise Freq. : 0 to 50 kHz	Noise Level : 50 mV _{PP}	—	30	—	—	dB
	P _{SRRR}				30	—	—	dB
Digital Output Delay Time	t _{SDX}	—	1 LSTTL + 100 pF, Pull-up: 500 Ω	—	50	—	200	ns
	t _{SDR}				50	—	200	ns
	t _{XD1}				50	—	200	ns
	t _{XD2}				50	—	200	ns
	t _{XD3}				50	—	200	ns

*1 Use the P-message weighted filter

*2 PCMRI input code "11010101"(MSM7540)

"11111111"(MSM7560)

*3 0.548 V_{rms} = 0 dBm0 = -3 dBm

Note: All ADPCM coder and decoder characteristics comply with ITU-T Recommendation G.721.

TIMING DIAGRAM

Transmit Side PCM/ADPCM Data Interface

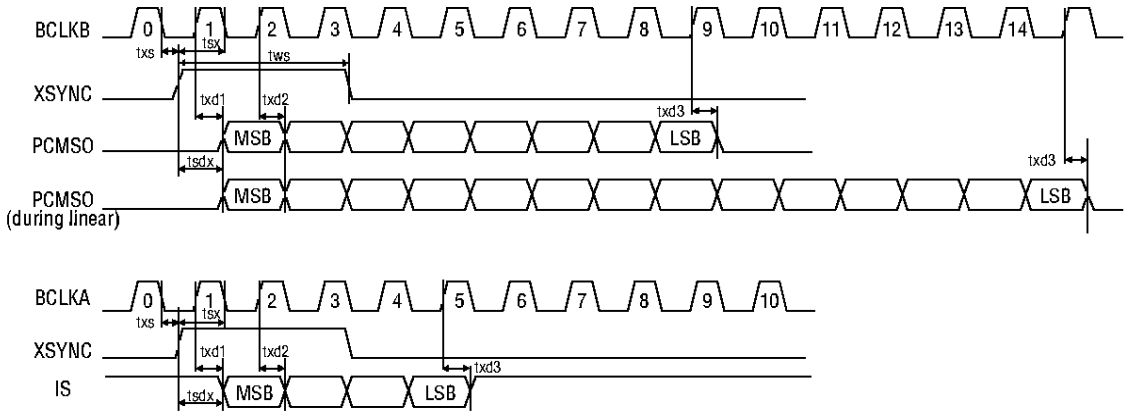

Receive Side PCM/ADPCM Data Interface

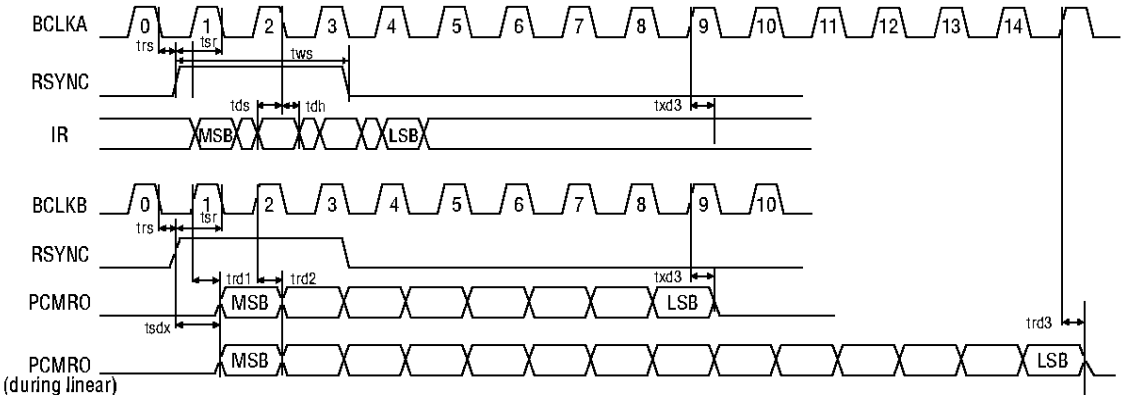

Note: Linear format

A code of an input/output level is determined by the 14-bit 2's complement. Refer to the table below for code format.

Input/Output level	MSB to LSB
+Full-scal	01111111111111
0	00000000000000
-Full-scal	10000000000000

APPLICATION CIRCUIT

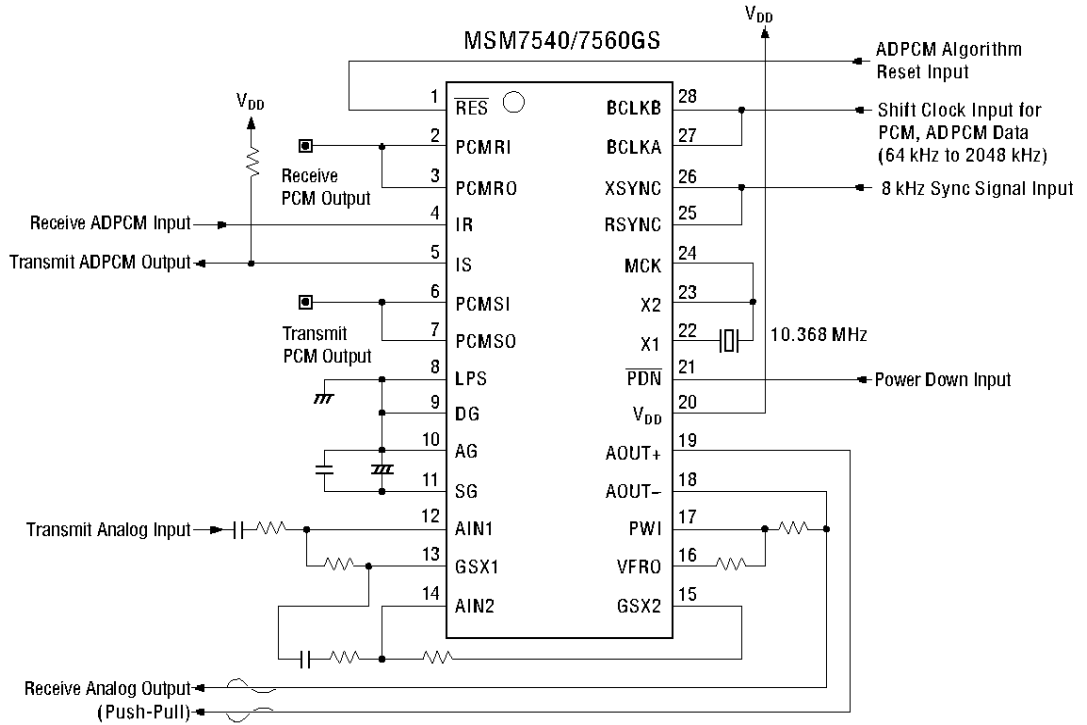

PACKAGE DIMENSIONS

(Unit : mm)

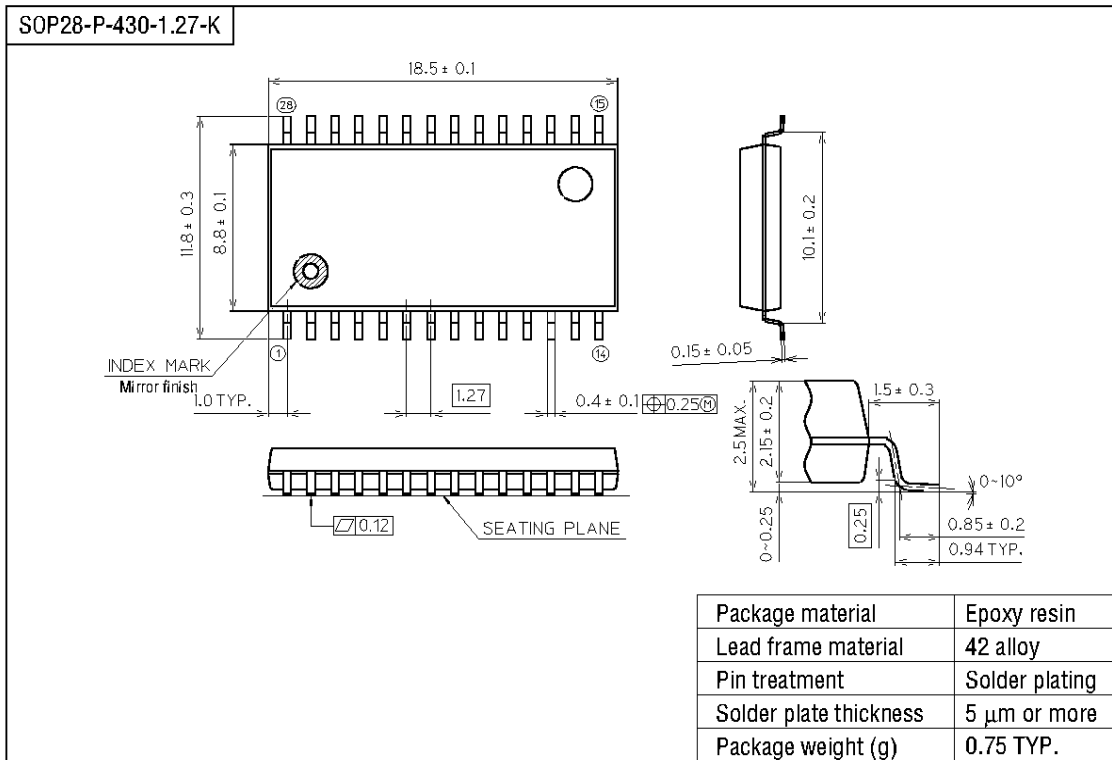

Notes for Mounting the Surface Mount Type Package

The SOP, QFP, TSOP, SOJ, QFJ (PLCC), SHP and BGA are surface mount type packages, which are very susceptible to heat in reflow mounting and humidity absorbed in storage. Therefore, before you perform reflow mounting, contact Oki's responsible sales person for the product name, package name, pin number, package code and desired mounting conditions (reflow method, temperature and times).