

Description

The ZMID5201, ZMID5202, and ZMID5203 family of inductive position sensor ICs are used for absolute rotary or linear motion sensing in automotive, industrial, medical, and consumer applications. The ZMID520x uses the physical principles of induction in a wire loop and eddy currents to detect the position of an electrically conducting target that is sliding or rotating above a set of coils, consisting of one transmitter coil and two receiver coils.

The three coils are typically printed as copper traces on a printed circuit board (PCB). They are arranged such that the transmitter coil induces a secondary voltage in the receiver coils that depends on the position of the metallic target above the coils.

A signal representative of the target's position over the coils is obtained by demodulating and processing the secondary voltages from the receiver coils. The target can be any kind of metal, such as aluminum, steel or a PCB with a printed copper layer.

The ZMID5201/02/03 ICs are fully qualified according to the automotive standard AEC-Q100 grade 0 (-40°C to 150°C ambient temperature).

Three versions with different output interfaces are available:

- ZMID5201: Analog output
- ZMID5202: PWM digital output
- ZMID5203: SENT digital output

Available Support

IDT provides Application Modules that demonstrate ZMID520x position sensing, including rotary, arc, and linear applications.

Physical Characteristics

- Wide operation temperature: -40 C to +150°C
- Supply voltage: 4.5V to 5.5V
- Small 14-TSSOP package

Typical Applications

- Rotary position sensors up to 360°; e.g. steering angle sensors, potentiometer replacement
- Small-angle sensors or arc-motion sensors; e.g. pedal, vehicle level, or valve sensors
- Linear motion sensors; e.g. linear-actuator position sensors, fluid-level sensors

Features

- Position sensing based on inductive principle
- Cost effective; no magnet required
- Immune to magnetic stray fields; no shielding required
- Suitable for harsh environments and extreme temperatures
- Only three wires (ground, supply, output)
- Nonvolatile user memory; programming through output pin
- Single IC supports on-axis and off-axis rotation, linear motion, and arc motion sensing
- High resolution, even for small angle ranges
- High accuracy: $\leq 0.2\%$ full scale
- 9-point user linearization
- Rotation sensing up to a full turn of 360°
- Overvoltage and reverse-polarity protection: -14V to +18V maximum, depending on product
- ESD and short-circuit protection
- Power or ground loss detection
- Facilitates redundant design requirements
- Programmable non-linearity correction
- ASIL B capable, according to user risk analysis
- Adaptive gain control supporting a wide range of coil designs and target displacement
- The ZMID5201/02/03 products are safety-related, intermediate hardware parts supporting ISO26262-compliant systems in regard to random failures

Application Circuit

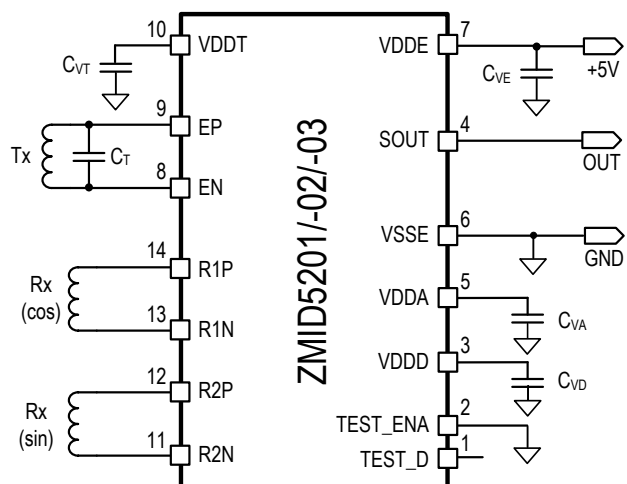

Block Diagram

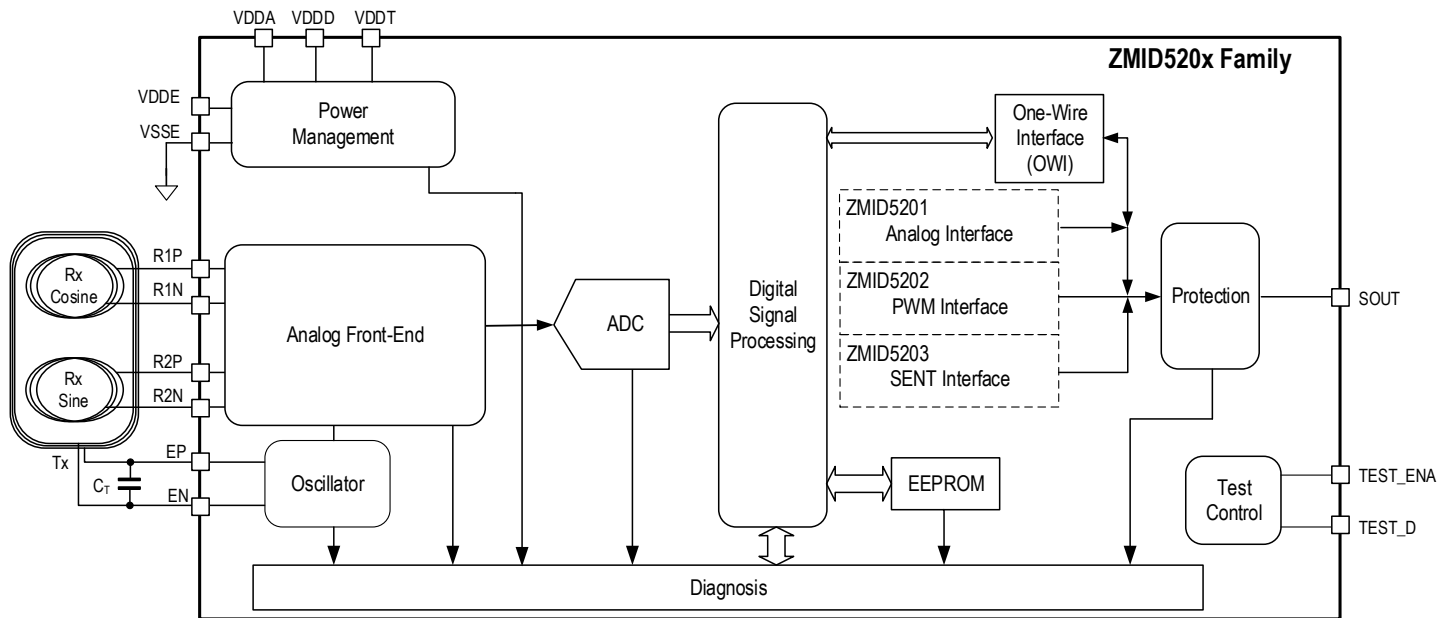

IMPORTANT NOTICE AND DISCLAIMER

RENESAS ELECTRONICS CORPORATION AND ITS SUBSIDIARIES (“RENESAS”) PROVIDES TECHNICAL SPECIFICATIONS AND RELIABILITY DATA (INCLUDING DATASHEETS), DESIGN RESOURCES (INCLUDING REFERENCE DESIGNS), APPLICATION OR OTHER DESIGN ADVICE, WEB TOOLS, SAFETY INFORMATION, AND OTHER RESOURCES “AS IS” AND WITH ALL FAULTS, AND DISCLAIMS ALL WARRANTIES, EXPRESS OR IMPLIED, INCLUDING, WITHOUT LIMITATION, ANY IMPLIED WARRANTIES OF MERCHANTABILITY, FITNESS FOR A PARTICULAR PURPOSE, OR NON-INFRINGEMENT OF THIRD PARTY INTELLECTUAL PROPERTY RIGHTS.

These resources are intended for developers skilled in the art designing with Renesas products. You are solely responsible for (1) selecting the appropriate products for your application, (2) designing, validating, and testing your application, and (3) ensuring your application meets applicable standards, and any other safety, security, or other requirements. These resources are subject to change without notice. Renesas grants you permission to use these resources only for development of an application that uses Renesas products. Other reproduction or use of these resources is strictly prohibited. No license is granted to any other Renesas intellectual property or to any third party intellectual property. Renesas disclaims responsibility for, and you will fully indemnify Renesas and its representatives against, any claims, damages, costs, losses, or liabilities arising out of your use of these resources. Renesas' products are provided only subject to Renesas' Terms and Conditions of Sale or other applicable terms agreed to in writing. No use of any Renesas resources expands or otherwise alters any applicable warranties or warranty disclaimers for these products.

(Disclaimer Rev.1.0 Mar 2020)

Corporate Headquarters

TOYOSU FORESIA, 3-2-24 Toyosu,
Koto-ku, Tokyo 135-0061, Japan
www.renesas.com

Contact Information

For further information on a product, technology, the most up-to-date version of a document, or your nearest sales office, please visit:
www.renesas.com/contact/

Trademarks

Renesas and the Renesas logo are trademarks of Renesas Electronics Corporation. All trademarks and registered trademarks are the property of their respective owners.