

EM30MSD Series

Service Plug for 200A Applications



High-Current



Vibration-Proof



Waterproof

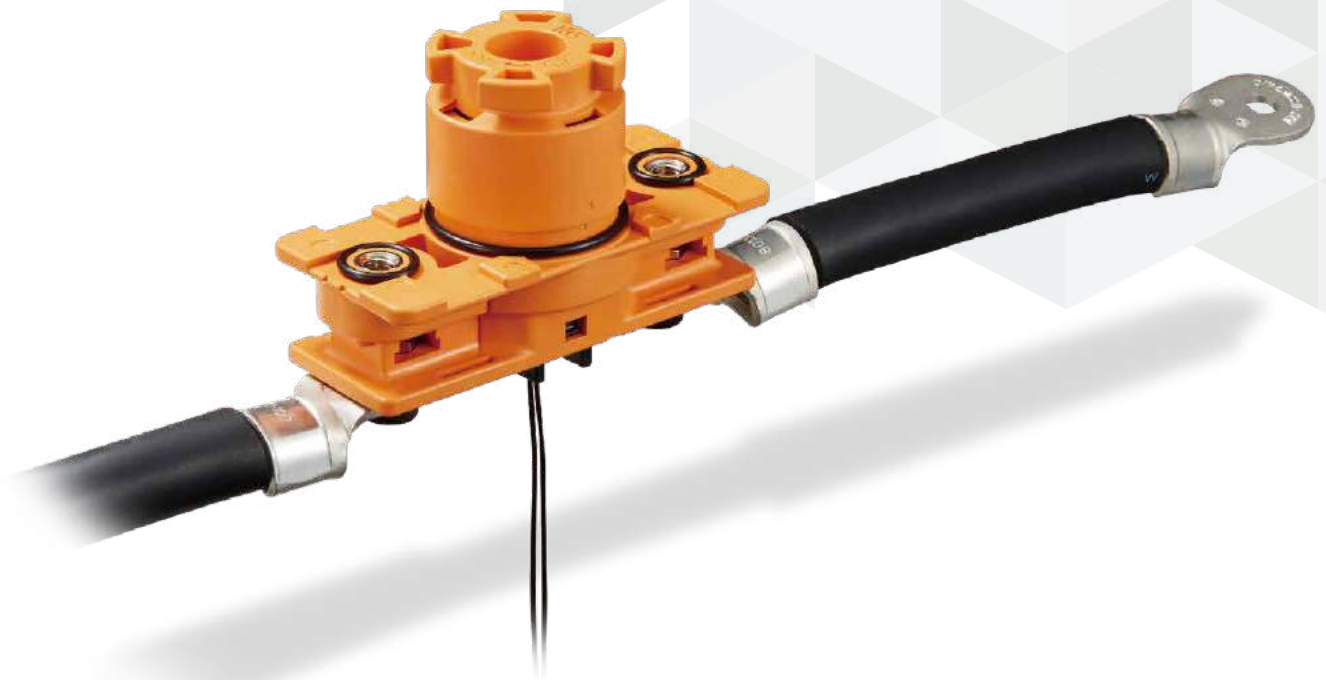

Features

1. High-current service plug for use up to 200A

2. Vibration-resistant with multi-point contact design

Vibration testing meets the following standards :
For vehicles JASO D014-3/ISO16750-3 Test IX
For railroads JIS E 4031 Division 2

3. The signal contact functions as an interlock switch to detect mated state.

4. Water-proof performance (IP68 compliant water resistance in mated condition)

IP68 : No water intrusion, while submerged in 2m water depth for 14 days in mated condition

5. Finger protection IP2X

6. UL TÜV Certified

■ What is Service Plug?

The connector ensures to disconnect the electric circuit, to ensure the safety of workers in high-voltage areas.

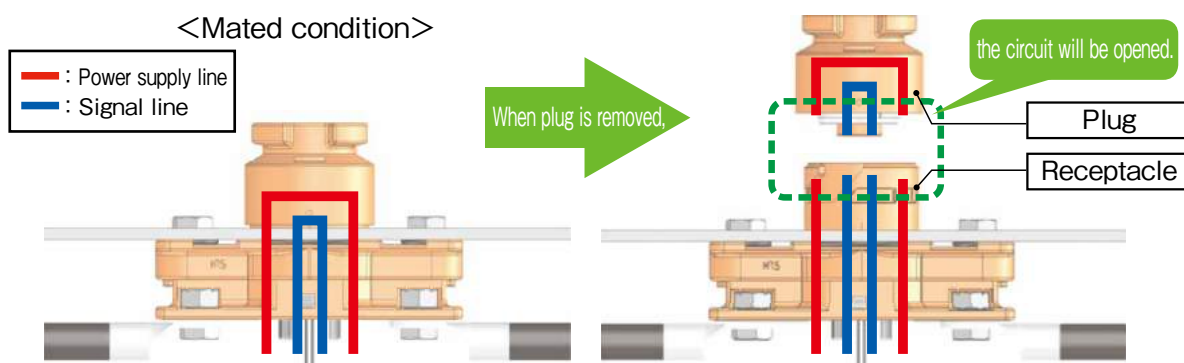

When the connector is unmated, the circuit is physically disconnected, ensuring the safety of workers.

Product Specifications

Rated Current	Power terminal (Note 1)	Signal terminal	Operating Temperature	-40 to +105°C
	200A	1A	Storage Temperature Range	-10 to +60°C
Rated Voltage	Power terminal	Signal terminal		
	1500V AC/DC	250V AC/DC		

Note 1 : When 100mm² or more wire is used

Items	Specifications	Conditions
Contact Resistance	Between power contacts : 0.5mΩ or less Between signal contacts : 90mΩ or less	Measured at 1A DC
Insulation Resistance	5000MΩ or more	Measured at 500V DC
Withstanding Voltage	No flashover or breakdown	Between power contacts : 4500V AC for 1 minute Between signal contacts : 750V AC for 1 minute
Vibration Resistance	No electrical discontinuity of 10 μs or more	10 to 55 to 10Hz/cycle, half amplitude 0.75mm 5 minutes/cycle, 10 cycles in each of the three axial directions
		10 to 2000Hz, average acceleration 57.9m/s ² 8 hours in three axial directions (ISO16750-3)
Shock Resistance	No electrical discontinuity of 10 μs or more	Acceleration : 490m/s ² , duration : 11ms, and half-sine wave in 3 directions, 3 cycles for each
Mating Durability	Contact resistance Between power contacts : 0.75mΩ or less Between signal contacts : 150mΩ or less	EM30MSD between plug and receptacle : 50 times (EM30MSD) : 200 times (EM30MSD-A) EM30MSD-GT8E (between signal connectors) (Note 1) : 30 times
Temperature Cycles	Insulation resistance : 5000MΩ or more	-40°C : 30 minutes → Room temperature : 2 to 3 minutes → +125°C : 30 minutes D7 → Room temperature : 2 to 3 minutes, 5 cycles
Humidity Resistance	Insulation resistance Minimum of 50MΩ (at high humidity) Minimum of 500MΩ (dry environment)	Left at a temperature of 40°C and in humidity of 90 to 95% for 96 hours.
Waterproof	No water intrusion inside connector	Submerged in 2m water depth for 14 days in mated condition.

Note 1 : Refer to the "Signal Connector" sections for information on the signal connector (GT8E connector).

[Reference] Derating Curve and Continuous Energizing Current (Current-Time Graph)

Measurement was performed by connecting a 100mm² wire in the mated state.

Derating Curve

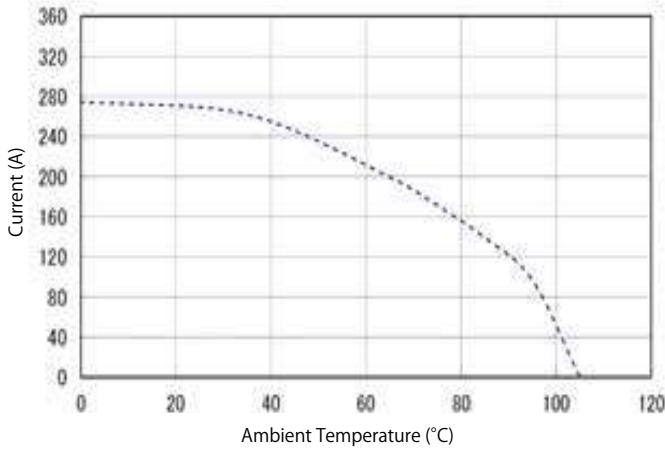

Continuous Energizing Current Graph (Current-Time Graph)

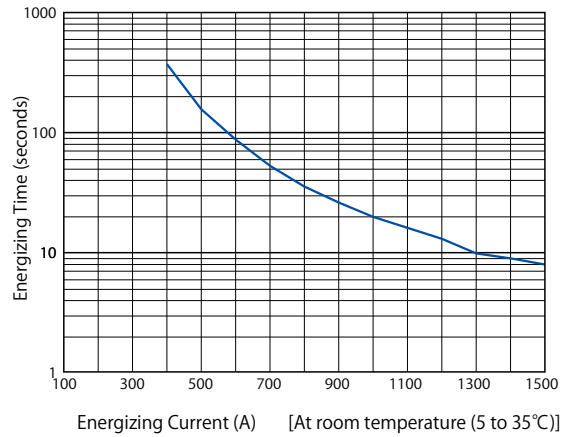

Operation below the derating curve (dotted line) is recommended.

Note : Derating curve could vary depending on cable type and measurement even under the same conditions.
Therefore, above data are guidelines and not connector specifications.

The continuous energizing current graph is reference data used for current values exceeding the rated values for a short time.

Materials / Finish

Item	Materials	Finish and Color	Remarks
Insulator	PBT Resin	Orange, Black	UL94V-0
Contact	Copper Alloy	Power Contact Side : Silver-plated	-
		Signal Contact Side : Tin Plated	-
Screw	Brass	Nickel Plated	-
O-ring	Hydrogenated Nitrile Rubber	Black	-

Product Number Structure

Refer to the chart below when determining the product specifications from the product number.
Please select from the product numbers listed in this catalog when placing orders.

EM 30 MSD - A (##)

① ② ③ ④ ⑤

① Series name	EM	④ Serial symbol	EM30MSD Plug-Receptacle Mating Durability Blank : 50 times -A : 200 times
② Shell size	30		
③ Type	MSD (Manual Service Disconnect) = Service plug	⑤ Specification	When different types of specifications are provided, attach (01), (02), ... for identification.

Product Composition

This product is provided with a plug and a receptacle.
The signal section uses a separately sold GT8E connector.

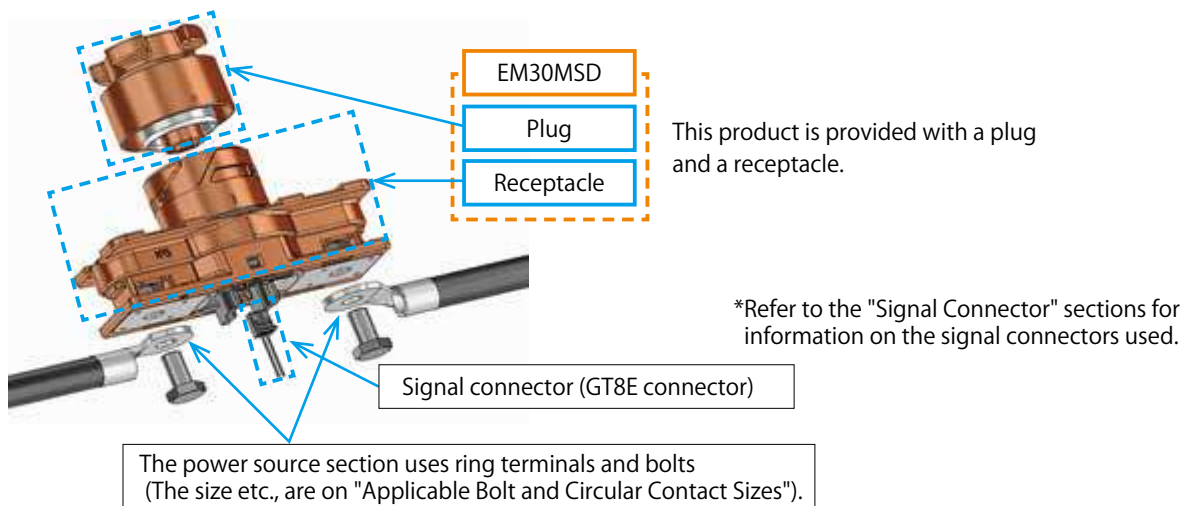

Service Plug

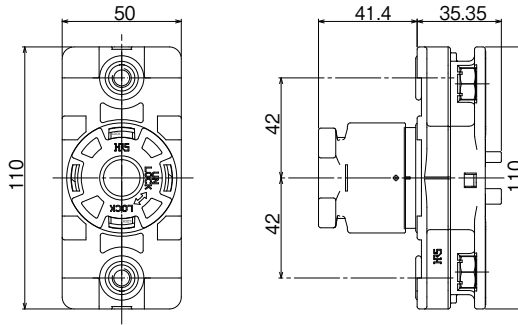

Part No.	HRS No.	Remarks	Purchase Unit
EM30MSD	CL0138-0200-0-00	Signal contact : Tin plated	1pc per box
EM30MSD(02)	CL0138-0200-0-02	Signal contact : Gold plated	
EM30MSD-A	CL0138-0206-0-00	Signal contact : Tin plated	
EM30MSD-A(02)	CL0138-0206-0-02	Signal contact : Gold plated	

Note : This product does not contain fuses.

Signal Connector : Main Body

Part No.	HRS No.	Purchase Unit
GT8E-2S-2C	CL0758-0030-6-00	100pcs per bag

Signal Connector : Applicable Crimp Contacts

Part No.	HRS No.	Remarks	Purchase Unit
GT8E-2022SCF	CL0758-0033-4-00	Tin Plated	10,000pcs per reel
GT8E-2022SCF(01)	CL0758-0033-4-01	Gold Plated	
GT8B-2428SCF	CL0758-0055-7-00	Tin Plated	
GT8B-2428SCF(01)	CL0758-0055-7-01	Gold Plated	
GT8E-2022SC	CL0758-0101-2-00	Tin Plated	100pcs per bag

Signal Connector : Wiring Tools

Part No.	HRS No.	Remarks
CM-105C	CL0901-0001-0-00	Press
AP105-GT8-2022S	CL0901-5144-8-00	GT8E-2022SCF for Applicator
AP105-GT8B-2428S	CL0901-5172-3-00	GT8B-2428SCF for Applicator
HT304/GT8E-2022S	CL0780-0042-6-00	GT8E-2022SC for Hand Crimping Tool

Applicable Bolt and Circular Contact Sizes

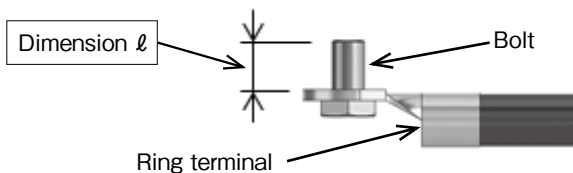

Secure positions	Bolt			R-form contact	
	Nominal designation of screw thread	Pitch	Length	Thickness	Hole diameter
To secure the housing	M8	1.25	10 to 12mm	-	-
To secure the ring terminal	M8	1.25	12 to 15mm	2.5 to 3.0mm	ϕ 8.4

Note : If you use any ring terminal with the thickness different from those shown in the above table, change the length of the bolt so that the dimension of l on the right Figure is 9 to 12.5mm.

Panel Mount Dimensions

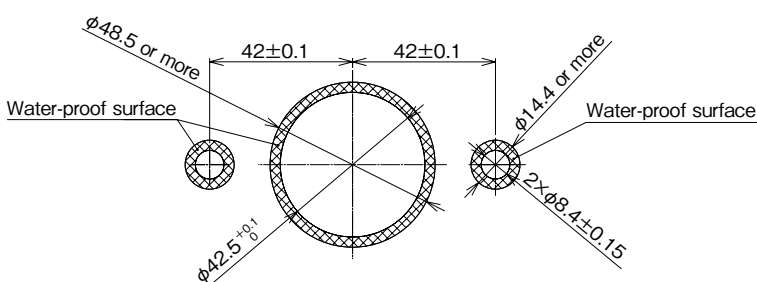

Recommended panel thickness $t=2$ to 4.5mm
Ensure that the surface roughness of the water-proof surface is $\sqrt{Rz3.2}$.

Safety Notes!

⚠ Warning

- For safety, never carry out insertion / withdrawal operations when a connector is in an energized state.
The signal contacts of this product have a sequence structure which disconnects the contact in the order shown below. For this reason, this product can be used with a circuit built for preventing operations with live wires in the power source circuit.
In order to prevent accidents during operations with live wires, be sure to use this product with a circuit built in to prevent operations with live wires.
- Be sure to check that the product is securely locked.
The following figure shows the outward appearance when the lock is complete.

Table: Circuit-Connecting Order

	Between A and B Power supply line Between C and D Signal line				
Status	① Not mated	② Plug inserted	③ Rotation/lock completed	④ Lock released	⑤ Unmated
Outward appearance/operation		<p>Insert the plug into the receptacle.</p>	<p>Rotate the plug clockwise. Lock is complete at the position matching the shown place.</p>	<p>Rotate the plug counter-clockwise.</p>	<p>Pull out the plug out of the receptacle.</p>
Connection		Power supply line is closed. When the signal line is open, no current flows.	The signal line is closed, and current flows in the power supply line.	The signal line is opened. No current flows in the power supply line.	
Circuit diagram	<p>Plug Receptacle</p>	<p>Plug Receptacle</p>	<p>Plug Receptacle</p>	<p>Plug Receptacle</p>	<p>Plug Receptacle</p>

