

PROPRIETY - NEXUS
ORDERING PART NUMBER: AJ-146

B AJ-146-CP

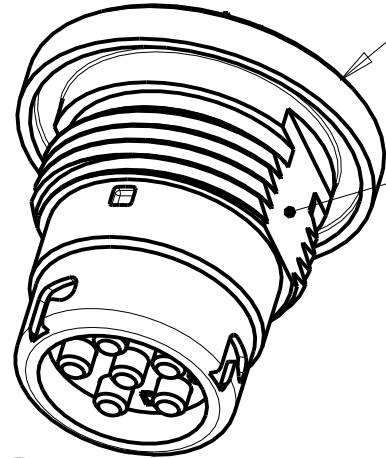

SEE NOTE 2

AJ-146-10
 6 CONDUCTOR
 PM PLUG SUB ASSY.

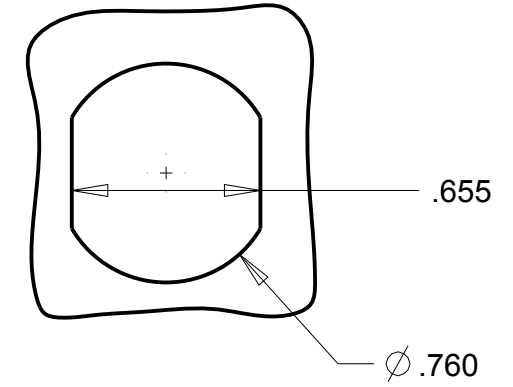

RECOMMENDED
 PANEL
 CUTOUT

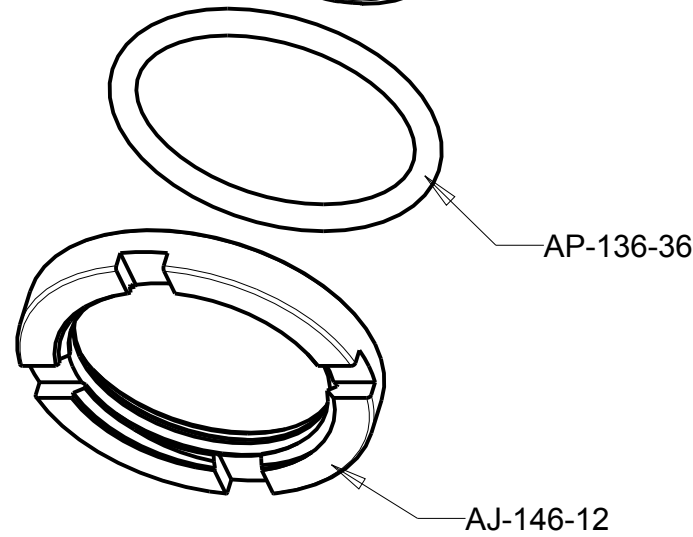

AP-136-36

AJ-146-12

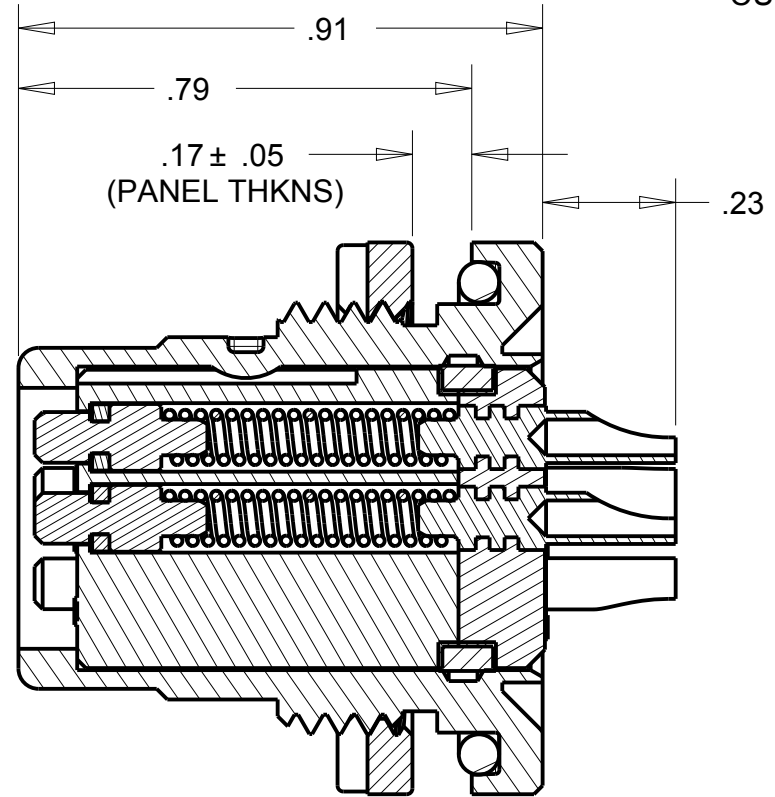
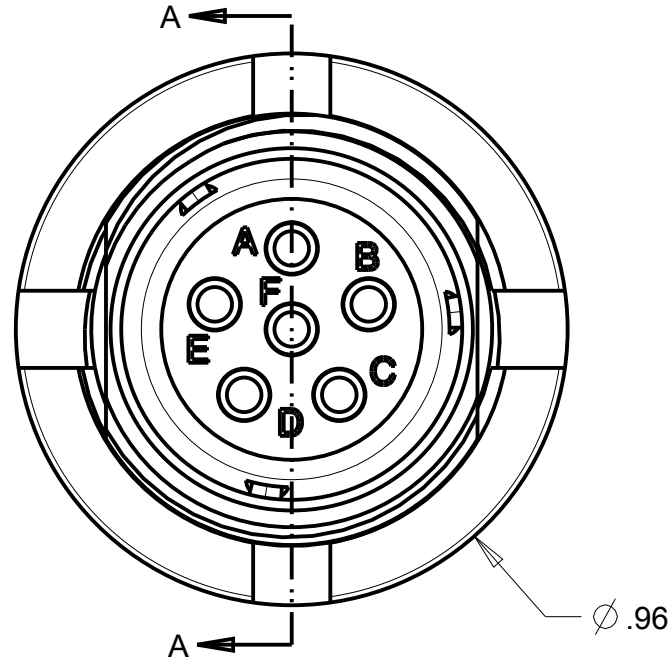

SECTION A-A
 SCALE 3.000

NOTES:
 1. CONNECTOR IS QUALIFIED TO MIL-DTL-55116.
 2. MILITARY PART IDENTIFYING NO.: M55116/10-0

THIS DOCUMENT CONTAINS PROPRIETARY INFORMATION OF NEXUS, INCORPORATED AND SUCH INFORMATION MAY NOT BE DISCLOSED TO OTHERS FOR ANY PURPOSE OR USED FOR ANY PURPOSE WITHOUT THE WRITTEN CONSENT OF NEXUS.

F	ADD .17± .05 (PANEL THKNS)	174	5/9 2013	HR	DWN.BY	GPH	DATE	05-Jun-09	MATERIAL	
E	ADD PANEL CUTOUT		6/19 2012	HR	CHECKED BY		DATE		FINISH	
D	CHG AJ-146-13 TO AP-136-36	115	11/11 2011	HR	APPR.BY		DATE		WEIGHT	SCALE = 4.00 :1
C	ADD DIMS	102	3/30 2011	HR	UNLESS OTHERWISE SPECIFIED DIMENSIONS ARE IN INCHES TOLERANCES ON .XX .XXX ANGLES — ±.003 ±.5°		TITLE JACK -6 PIN SOLDER CUP, PM		NEXUS STAMFORD, CONN	
B	ADD NOTES 1 THRU 3	035	12/15 2009	GPH						
A	NEW RELEASE	032	11/23 2009	GPH					B	AJ-146-CP
LET.	REVISION	CN #	DATE	CHK.			DO NOT SCALE DWG.		SHEET 1 OF 1	