

features

- Reduced size, light weight and small mounting area
- Quick thermal response
- Curie temperature: 70°C, 80°C, 100°C
- Marking: Black coating for 70°C Curie temperature
Brown coating for 80°C Curie temperature
Blue coating for 100°C Curie temperature
- Products with lead-free terminations meet EU RoHS and China RoHS requirements

dimensions and construction

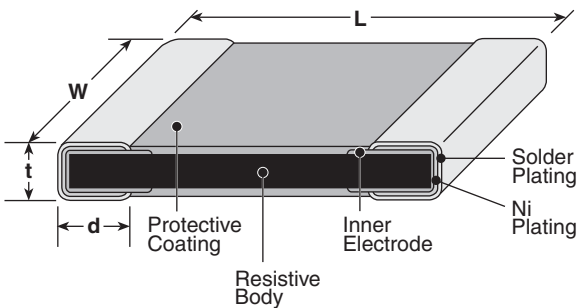

Type (Inch Size Code)	Dimensions inches (mm)			
	L	W	t	d
2A (0805)	.079±.008 (2.0±0.2)	.049±.008 (1.25±0.2)	.039±.008 (1.0±0.2)	.016±.008 (0.4±0.2)
2B (1206)	.126±.008 (3.2±0.2)	.063±.008 (1.6±0.2)		.02±.012 (0.5±0.3)

ordering information

New Part #	PT72	2A	T	70C	TE	471
	Type	Size Code	Termination Material	Curie Temperature	Packaging	Nominal Resistance
		2A: 0805 2B: 1206	T: Sn (Other termination styles available, contact factory for options)	70°C 80°C 100°C	TE: 7" embossed plastic (3,000 pieces/reel)	2 significant figures + 1 multiplier

For further information on packaging, please refer to Appendix A.

typical circuit schematic

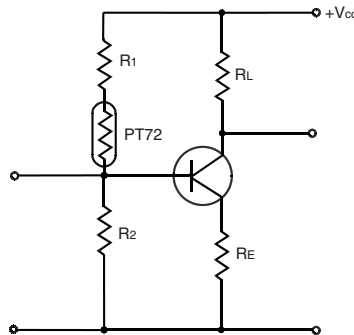

applications and ratings

Part Designation	Curie Temperature	Nominal Resistance (Ω)	Resistance Tolerance	Temperature @ R25 x 7	Absolute Maximum Working Voltage	Operating Temperature Range
PT722A	70°C	470Ω	±50%	85°C ± 10°C	16V	-55°C to +125°C
	80°C			95°C ± 10°C		
	100°C			115°C ± 10°C		
PT722B	70°C	120Ω, 470Ω, 1kΩ		85°C ± 10°C		
	80°C	50Ω, 470Ω, 1kΩ		95°C ± 10°C		
	100°C	470Ω, 1kΩ		115°C ± 10°C		

environmental applications

Temperature Characteristics

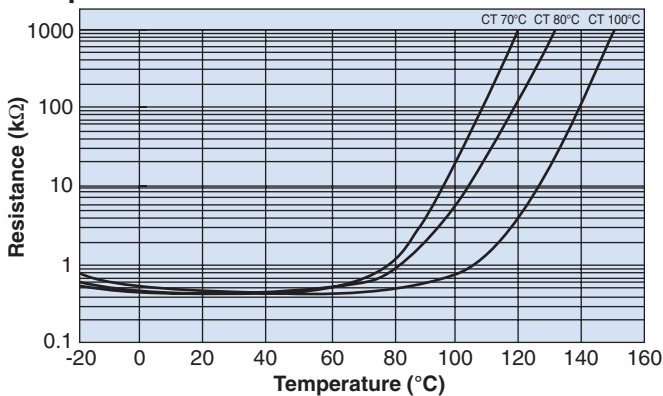

Performance Characteristics

Parameter	Requirement Δ R ±%		Test Method
	Limit	Typical	
Resistance to Solder Heat	±20.0%	±4.0%	260°C ± 5°C, 10 seconds ± 1 second
Rapid Change of Temperature	±20.0%	±4.0%	-55°C (30 minutes), +125°C (30 minutes), 5 cycles
Resistance	±50.0%	±35.0%	25°C
Humidity Resistance	±20.0%	±4.0%	40°C ± 2°C, 90 - 95% RH, 1000 hours
Load Life	±20.0%	±4.0%	25°C ± 2°C, 1000 hours, DC16 voltage load