

PTB 20111

85 Watts, 860–900 MHz

Cellular Radio RF Power Transistor

Description

The 20111 is a class AB, NPN, common emitter RF power transistor intended for 25 Vdc operation from 860 to 900 MHz. Rated at 85 watts minimum output power, it may be used for both CW and PEP applications. Ion implantation, nitride surface passivation and gold metallization are used to ensure excellent device reliability. 100% lot traceability is standard.

- 26 Volt, 860–900 MHz Characteristics
 - Output Power = 85 Watts
 - Collector Efficiency = 50% at 85 Watts
 - IMD = -30 dBc Max at 60 W(PEP)
- Class AB Characteristics
- Gold Metallization
- Silicon Nitride Passivated

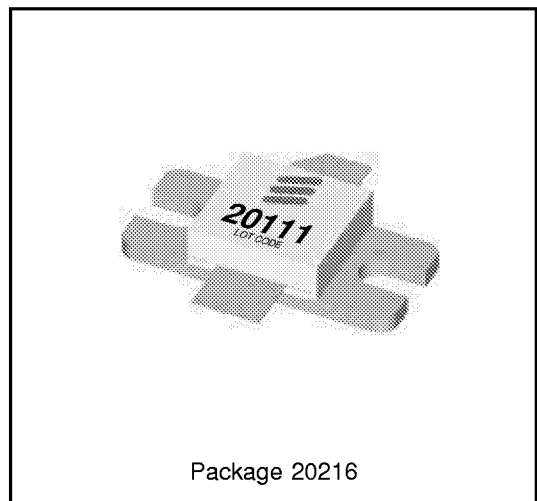
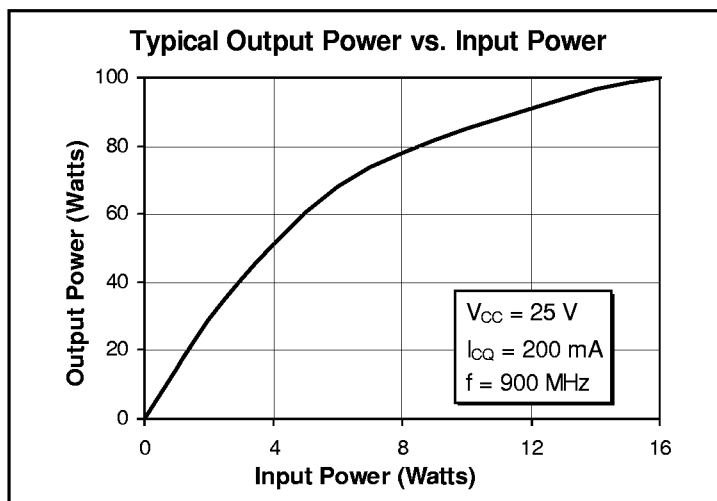

Maximum Ratings

Parameter	Symbol	Value	Unit
Collector-Emitter Voltage	V_{CER}	40	Vdc
Collector-Base Voltage	V_{CBO}	65	Vdc
Emitter-Base Voltage (collector open)	V_{EBO}	4.0	Vdc
Collector Current (continuous)	I_C	20	Adc
Total Device Dissipation at $T_{flange} = 25^{\circ}C$ Above $25^{\circ}C$ derate by	P_D	159 0.91	Watts W/ $^{\circ}C$
Storage Temperature	T_{stg}	150	$^{\circ}C$
Thermal Resistance ($T_{flange} = 70^{\circ}C$)	$R_{\theta JC}$	1.1	$^{\circ}C/W$

Electrical Characteristics (100% Tested)

Characteristic	Conditions	Symbol	Min	Typ	Max	Units
Breakdown Voltage C to E	$I_B = 0 \text{ A}, I_C = 100 \text{ mA}$	$V_{(BR)CEO}$	25	30	—	Volts
Breakdown Voltage C to E	$V_{BE} = 0 \text{ V}, I_C = 100 \text{ mA}$	$V_{(BR)CES}$	55	70	—	Volts
Breakdown Voltage E to B	$I_C = 0 \text{ A}, I_E = 5 \text{ mA}$	$V_{(BR)EBO}$	3.5	5	—	Volts
DC Current Gain	$V_{CE} = 5 \text{ V}, I_C = 1 \text{ A}$	h_{FE}	20	50	100	—

RF Specifications (100% Tested)

Characteristic	Symbol	Min	Typ	Max	Units
Gain ($V_{CC} = 25 \text{ Vdc}, P_{out} = 85 \text{ W}, I_{CQ} = 200 \text{ mA}, f = 860\text{--}900 \text{ MHz}$)	G_{pe}	8.5	9.5	—	dB
Collector Efficiency ($V_{CC} = 25 \text{ Vdc}, P_{out} = 85 \text{ W}, I_{CQ} = 200 \text{ mA}, f = 860\text{--}900 \text{ MHz}$)	η_C	50	—	—	%
Load Mismatch Tolerance ($V_{CC} = 25 \text{ Vdc}, P_{out} = 60 \text{ W(PEP)}, I_{CQ} = 200 \text{ mA}, f = 860\text{--}900 \text{ MHz}$ —all phase angles at frequency of test)	Ψ	—	—	10:1	—

Impedance Data

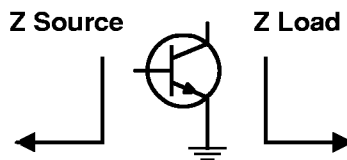

Frequency MHz	Z Source		Z Load	
	R	jX	R	jX
860	1.7	-0.8	1.7	-1.6
880	2.0	-1.2	1.8	-1.9
900	1.7	-0.8	1.7	-1.6

Typical Performance

