

---

# PF0341A Series

MOS FET Power Amplifier Module for UHF Band

# HITACHI

ADE-208-338C (Z)  
4th Edition  
July 1996

---

## Features

- Small package:  $30 \times 10 \times 5.9$  mm
- High output power at low voltage: 2 W Typ at 4.8 V
- Low power control current: 200  $\mu$ A Typ

## Ordering Information

| Type Name | Operating Frequency |
|-----------|---------------------|
| PF0341A   | 400 to 430 MHz      |
| PF0342A   | 440 to 470 MHz      |
| PF0343A   | 470 to 490 MHz      |
| PF0344A   | 490 to 512 MHz      |
| PF0345A   | 380 to 400 MHz      |

## Pin Arrangement

• RF-J1

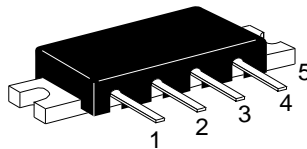

1: Pin  
2:  $V_{PC}$   
3:  $V_{DD}$   
4: Pout  
5: GND

## PF0341A Series

### Internal Diagram and External Circuit

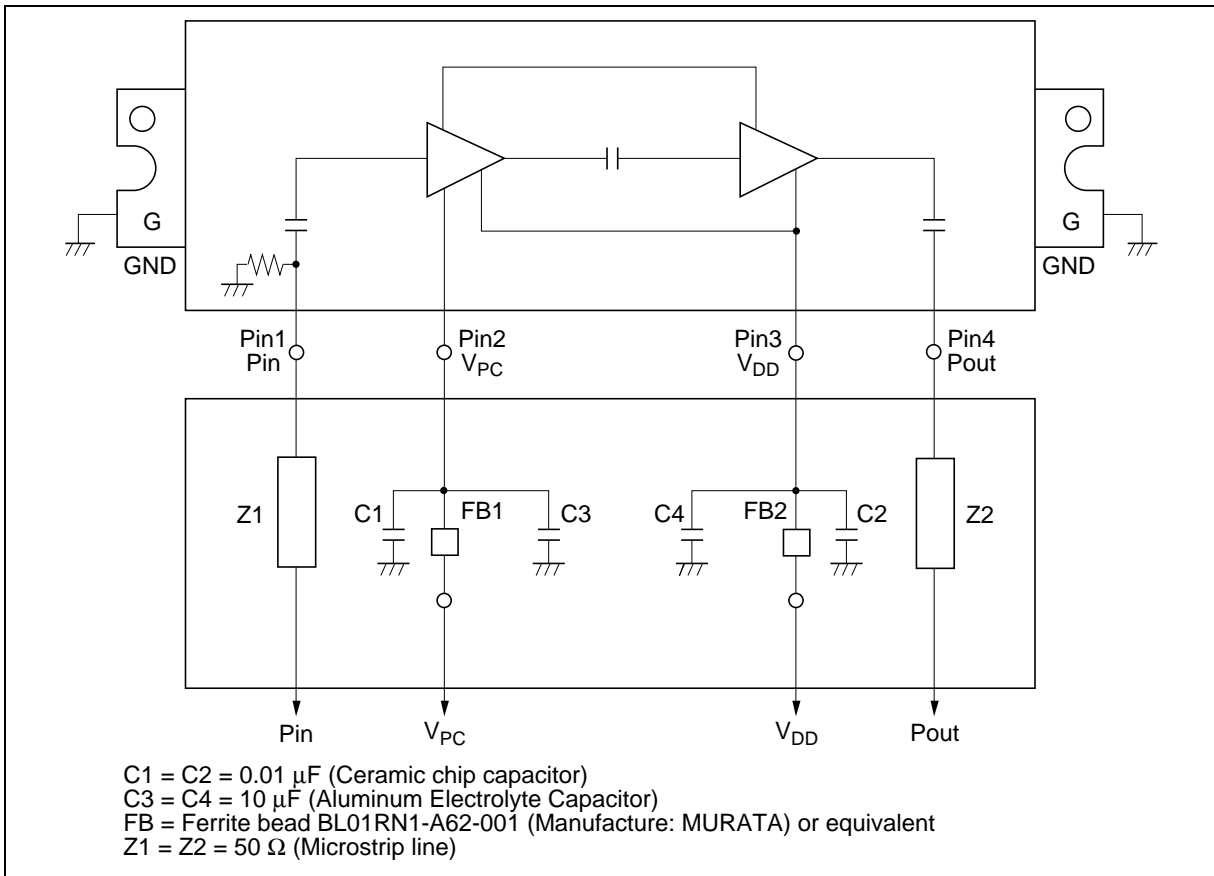

### Absolute Maximum Ratings ( $T_c = 25^\circ\text{C}$ )

| Item                       | Symbol     | Rating      | Unit             |
|----------------------------|------------|-------------|------------------|
| Supply voltage             | $V_{DD}$   | 17          | V                |
| Supply current             | $I_{DD}$   | 3           | A                |
| PC voltage                 | $V_{PC}$   | 4.5         | V                |
| Input power                | Pin        | 50          | mW               |
| Operating case temperature | $T_c$ (op) | -30 to +100 | $^\circ\text{C}$ |
| Storage temperature        | $T_{stg}$  | -40 to +110 | $^\circ\text{C}$ |

**Electrical Characteristics** (Tc = 25°C)

| Item                    | Symbol    | Min                      | Typ | Max | Unit          | Test Condition  |
|-------------------------|-----------|--------------------------|-----|-----|---------------|---|
| Drain cutoff current    | $I_{DS}$  | —                        | —   | 100 | $\mu\text{A}$ | $V_{DD} = 17\text{ V}$ , $V_{PC} = 0\text{ V}$ ,<br>$R_L = R_g = 50\ \Omega$ ,  |
| Total efficiency        | $\eta_T$  | 35                       | 38  | —   | %             | Pin = 20 mW, $V_{DD} = 9.6\text{ V}$ , Pout = 7 W (at $V_{PC}$ controlled), $R_L = R_g = 50\ \Omega$ , Tc = 25°C                          |
| 2nd harmonic distortion | 2nd H.D.  | —                        | -30 | -25 | dBc           |   |
| 3rd harmonic distortion | 3rd H.D.  | —                        | -60 | -40 | dBc           |   |
| Input VSWR              | VSWR (in) | —                        | 2.0 | 3.0 | —             |   |
| Output power (1)        | Pout (1)  | 7                        | 8   | —   | W             | Pin = 20 mW, $V_{DD} = 9.6\text{ V}$ ,<br>$V_{PC} = 3.5\text{ V}$ , $R_L = R_g = 50\ \Omega$  |
| Output power (2)        | Pout (2)  | 1.8                      | 2   | —   | W             | Pin = 20 mW, $V_{DD} = 4.8\text{ V}$ ,<br>$V_{PC} = 3.5\text{ V}$ , $R_L = R_g = 50\ \Omega$  |
| Load VSWR tolerance     | —         | No degradation           |     |     | —             | Pin = 20 mW, $V_{DD} = 15\text{ V}$ ,<br>Pout $\leq 7\text{ W}$ , (at $V_{PC}$ controlled),<br>Output VSWR = 6:1 All phases               |
| Stability               | —         | No parasitic oscillation |     |     | —             | Pin = 20 mW, $V_{DD} = 4.8\text{ to }15\text{ V}$ ,<br>Pout $\leq 7\text{ W}$ , (at $V_{PC}$ controlled),<br>Output VSWR = 6:1 All phases |

**Mechanical Characteristics**

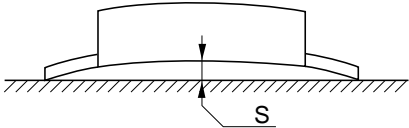
| Item                                    | Measuring Conditions   | Spec                |
|---|--|---------------------|
| Torque for screw up the heatsink flange | M2.6 Screw Bolts   | 1.5 to 3.5 kg•cm    |
| Warp size of the heatsink flange: S     |  | S = 0<br>+0.1/-0 mm |

# PF0341A Series

## Characteristic Curves

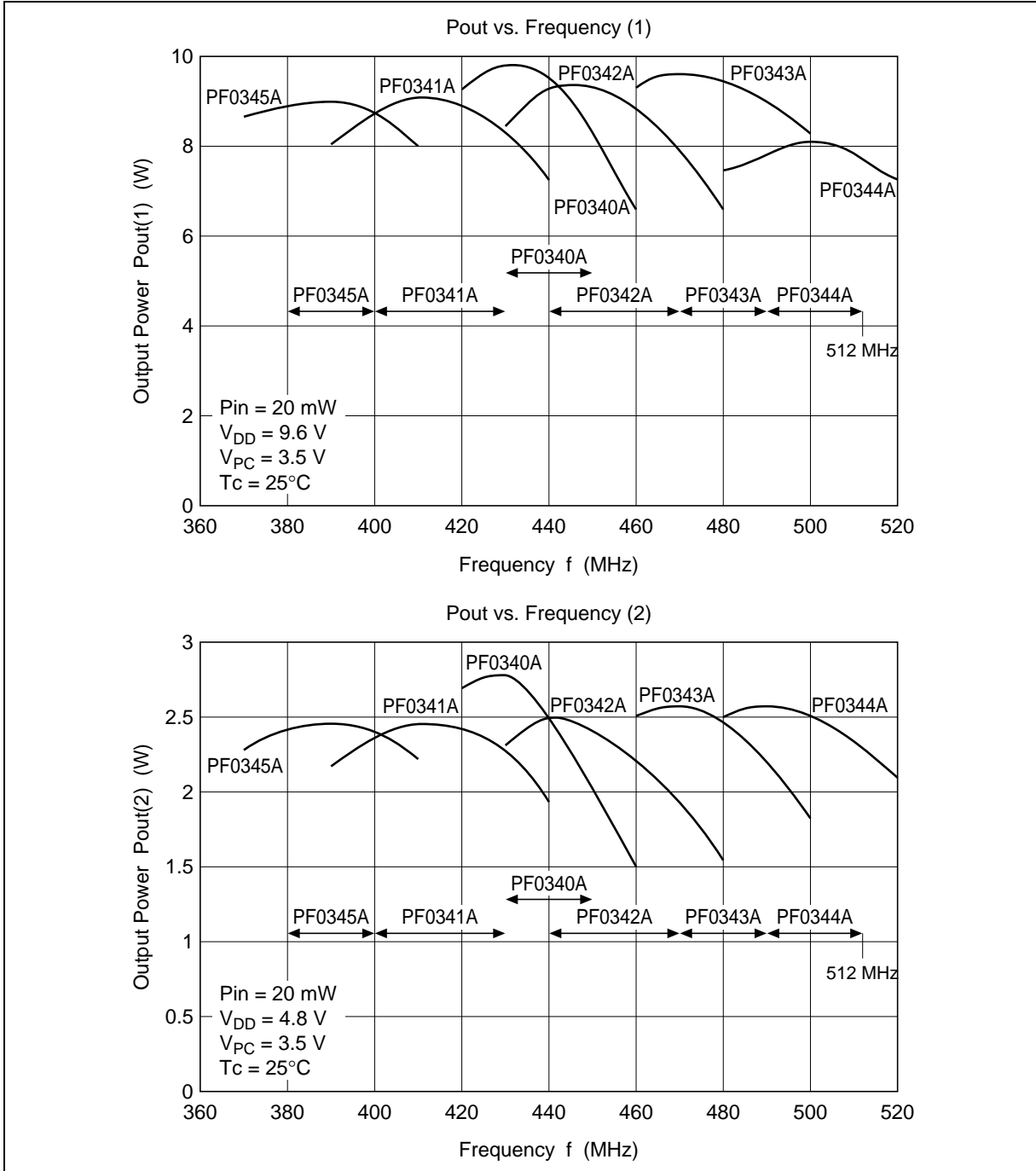

## PF0341A Series

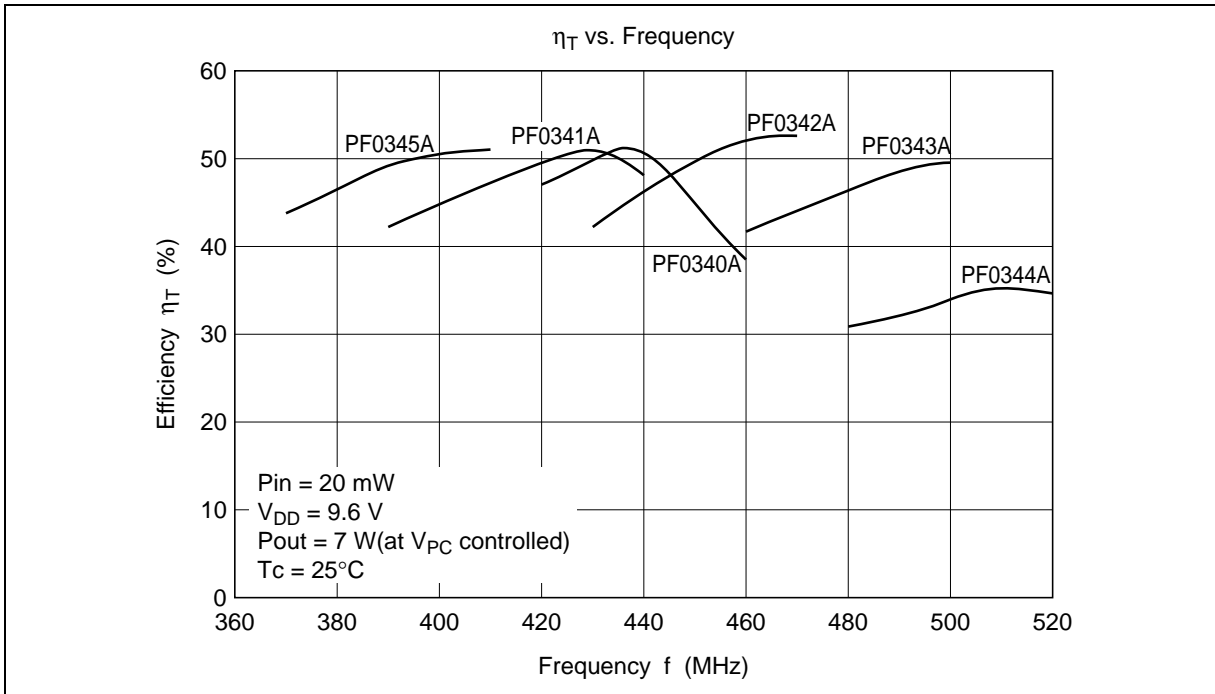

# PF0341A Series

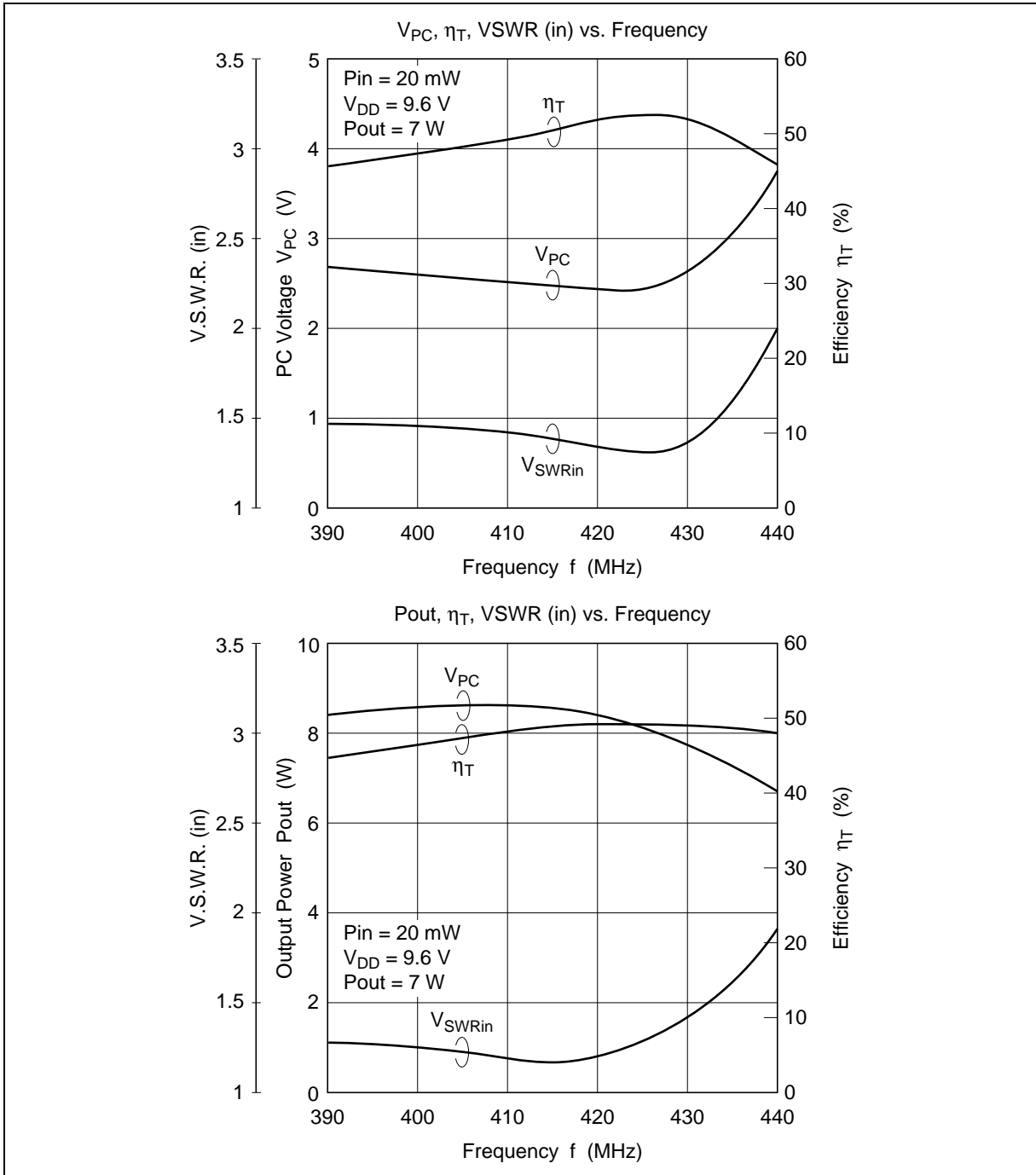

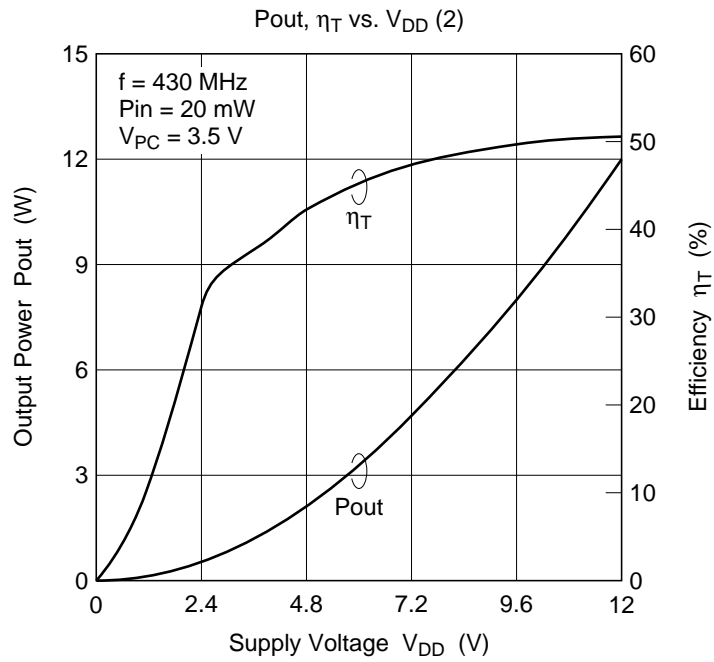
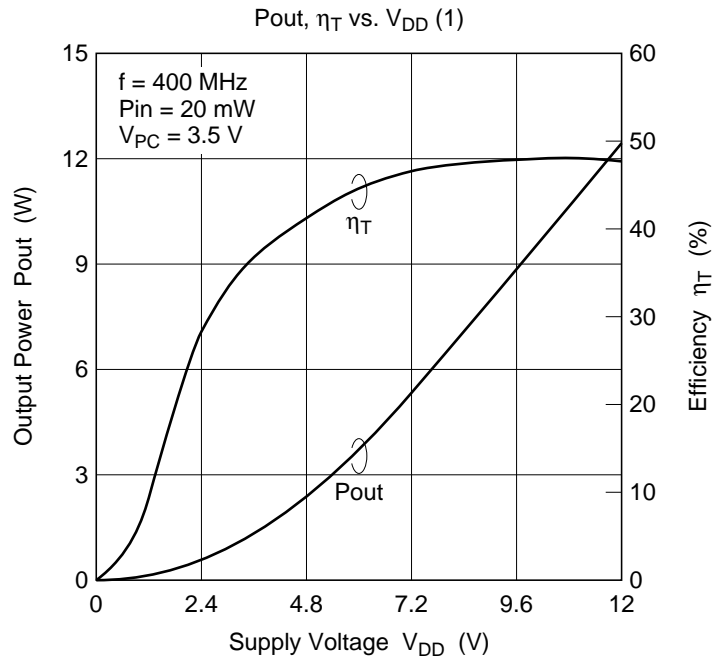

# PF0341A Series

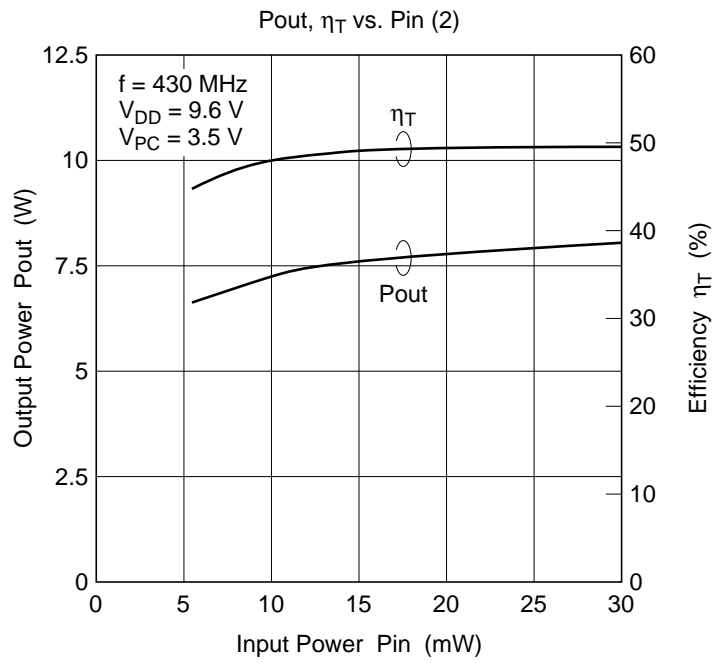
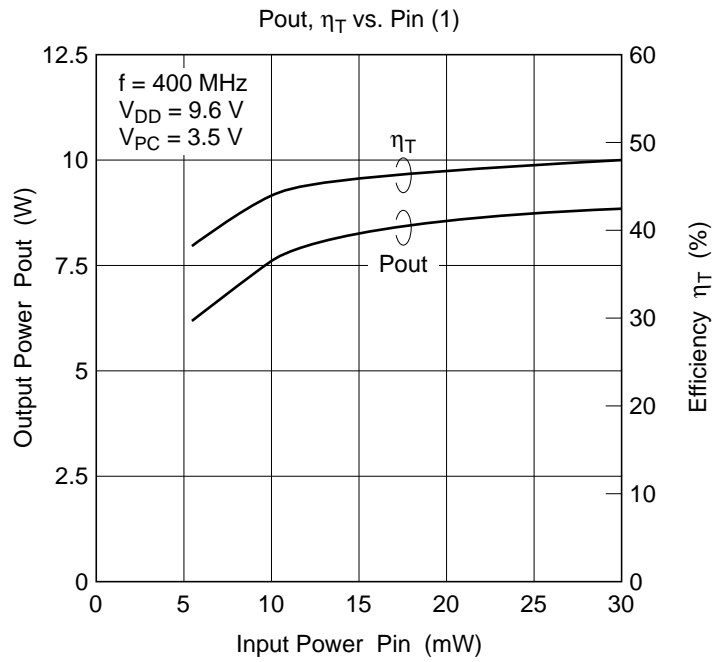

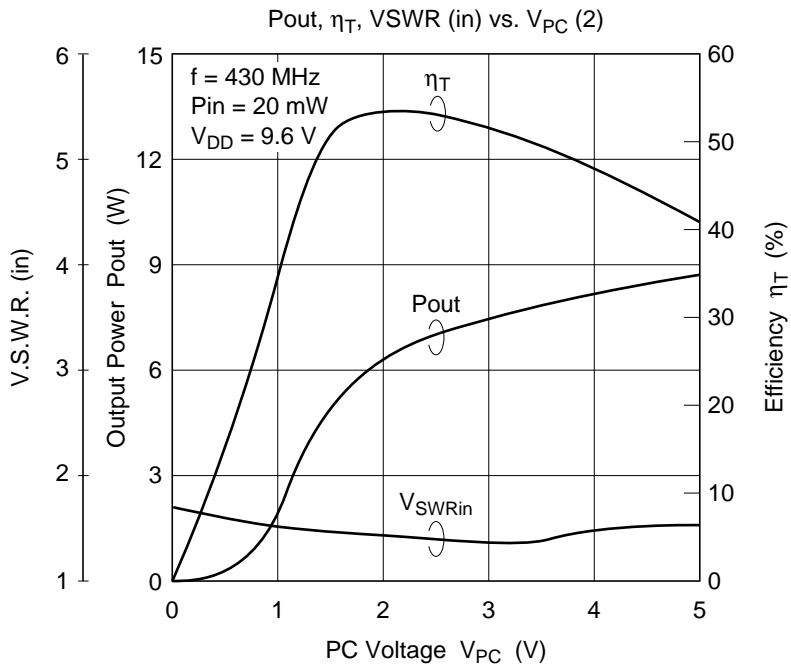
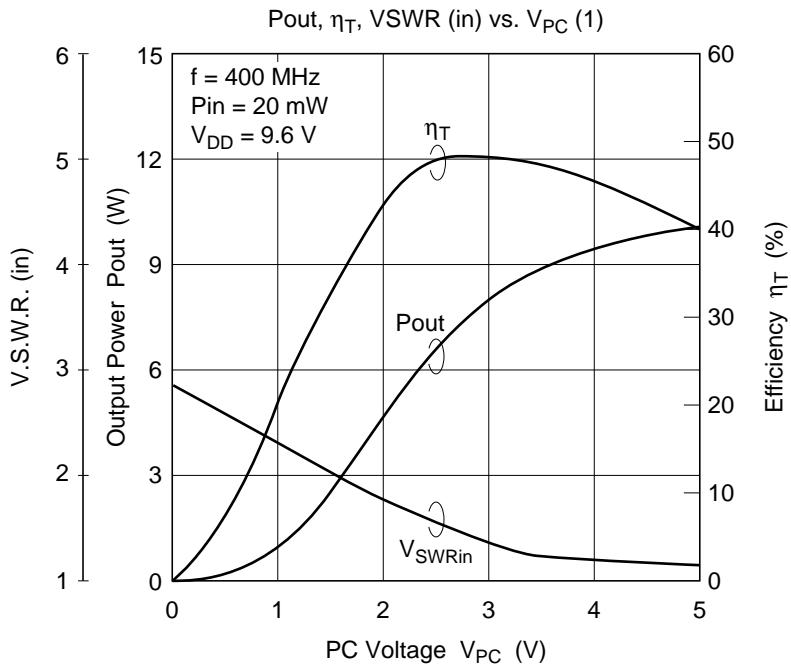

# PF0341A Series

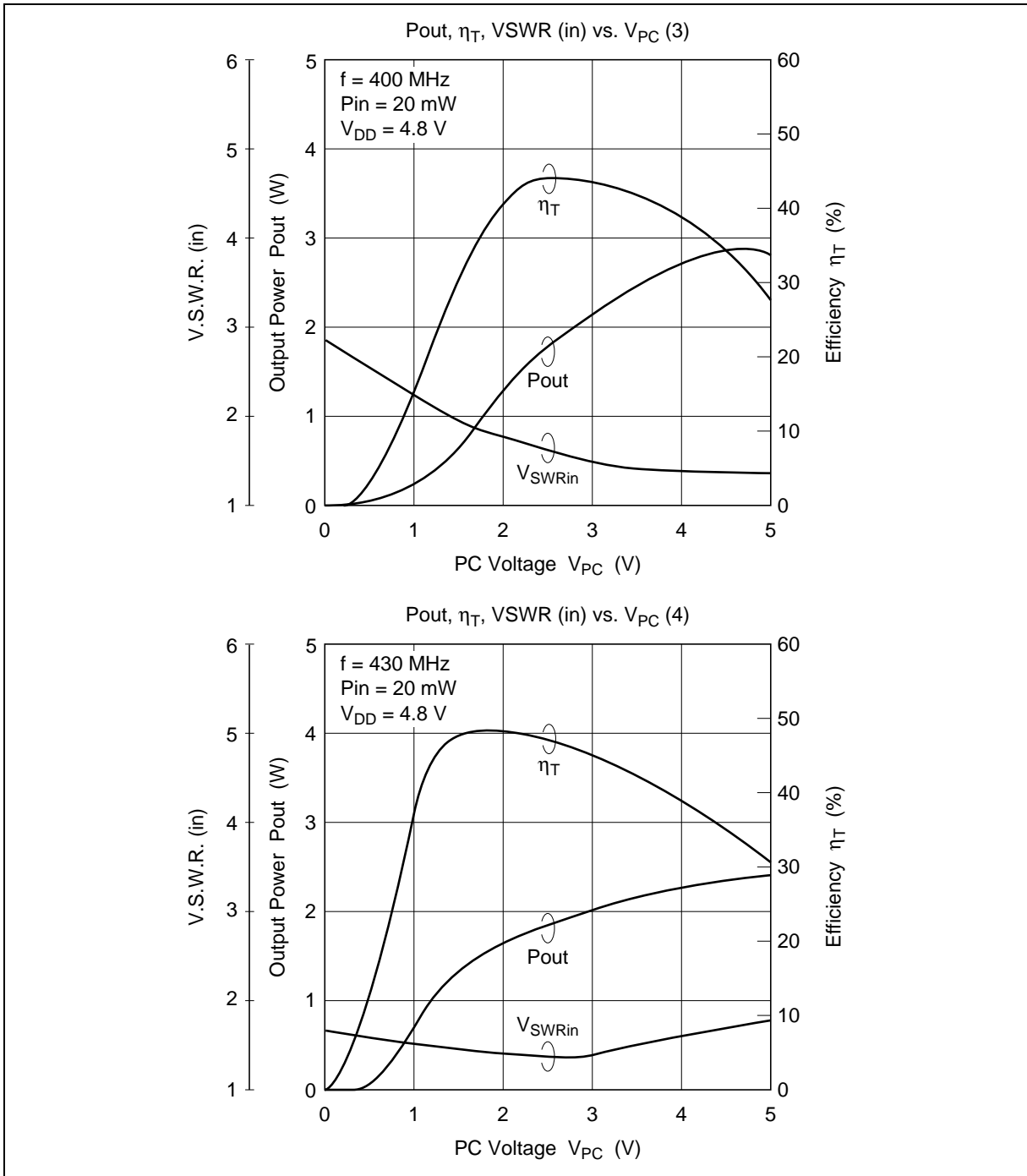

Package Dimensions

Unit: mm

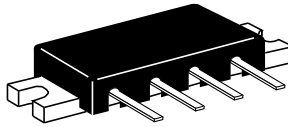
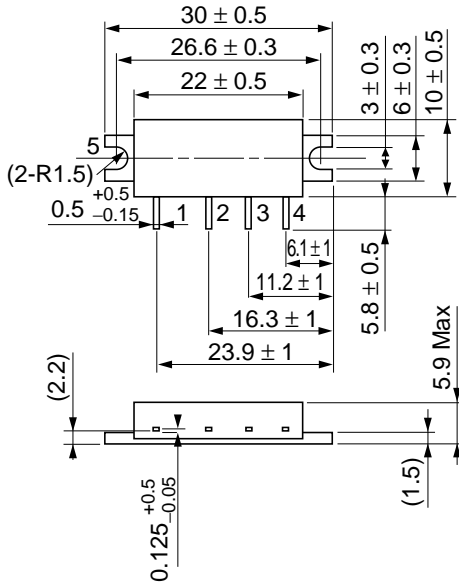

|                          |       |
|--------------------------|-------|
| Hitachi Code             | RF-J1 |
| JEDEC                    | —     |
| EIAJ                     | —     |
| Weight (reference value) | —     |

When using this document, keep the following in mind:

1. This document may, wholly or partially, be subject to change without notice.
2. All rights are reserved: No one is permitted to reproduce or duplicate, in any form, the whole or part of this document without Hitachi's permission.
3. Hitachi will not be held responsible for any damage to the user that may result from accidents or any other reasons during operation of the user's unit according to this document.
4. Circuitry and other examples described herein are meant merely to indicate the characteristics and performance of Hitachi's semiconductor products. Hitachi assumes no responsibility for any intellectual property claims or other problems that may result from applications based on the examples described herein.
5. No license is granted by implication or otherwise under any patents or other rights of any third party or Hitachi, Ltd.
6. **MEDICAL APPLICATIONS:** Hitachi's products are not authorized for use in **MEDICAL APPLICATIONS** without the written consent of the appropriate officer of Hitachi's sales company. Such use includes, but is not limited to, use in life support systems. Buyers of Hitachi's products are requested to notify the relevant Hitachi sales offices when planning to use the products in **MEDICAL APPLICATIONS**.

---

---

# HITACHI

## Hitachi, Ltd.

Semiconductor & IC Div.  
Nippon Bldg., 2-6-2, Ohte-machi, Chiyoda-ku, Tokyo 100, Japan  
Tel: Tokyo (03) 3270-2111  
Fax: (03) 3270-5109

### For further information write to:

Hitachi America, Ltd.  
Semiconductor & IC Div.  
2000 Sierra Point Parkway  
Brisbane, CA. 94005-1835  
U S A  
Tel: 415-589-8300  
Fax: 415-583-4207

Hitachi Europe GmbH  
Electronic Components Group  
Continental Europe  
Dornacher StraÙe 3  
D-85622 Feldkirchen  
M nchen  
Tel: 089-9 91 80-0  
Fax: 089-9 29 30 00

Hitachi Europe Ltd.  
Electronic Components Div.  
Northern Europe Headquarters  
Whitebrook Park  
Lower Cookham Road  
Maidenhead  
Berkshire SL6 8YA  
United Kingdom  
Tel: 0628-585000  
Fax: 0628-778322

Hitachi Asia Pte. Ltd.  
16 Collyer Quay #20-00  
Hitachi Tower  
Singapore 0104  
Tel: 535-2100  
Fax: 535-1533

Hitachi Asia (Hong Kong) Ltd.  
Unit 706, North Tower,  
World Finance Centre,  
Harbour City, Canton Road  
Tsim Sha Tsui, Kowloon  
Hong Kong  
Tel: 27359218  
Fax: 27306071

Copyright © Hitachi, Ltd., 1997. All rights reserved. Printed in Japan.