

PC Card (PCMCIA) Interface Switch

DESCRIPTION

The Si9711 is a monolithic switch designed to meet the needs of the PC Card interface. The inputs are fully CMOS compatible and incorporate all the level shift and interface required to be driven by any CMOS driver. The external inputs can be driven to 3.3 V or 5 V by setting V_L at the appropriate level. The switches are low R_{ON} and can carry the maximum currents found on the PC Card interface.

The 5 V and 3.3 V switches do not have the parasitic diode found in vertical DMOS power switches.

Low R_{ON} is achieved by using MOSFETs driven off the + 12 V_{IN} input. All level shifting is built into the Si9711.

The Si9711 is packaged in an SO-16 package and is rated over the commercial temperature range 0 to 70 °C.

The Si9711 is available in both standard and lead (Pb)-free packages.

FEATURES

- Single SO-16 Package
- CMOS Inputs with Hysteresis
- Extremely Low R_{ON}
- Reverse Blocking Switches
- HiZ Outputs in the Off-State
- Low Power Consumption
- Safe Power-Up

FUNCTIONAL BLOCK DIAGRAM

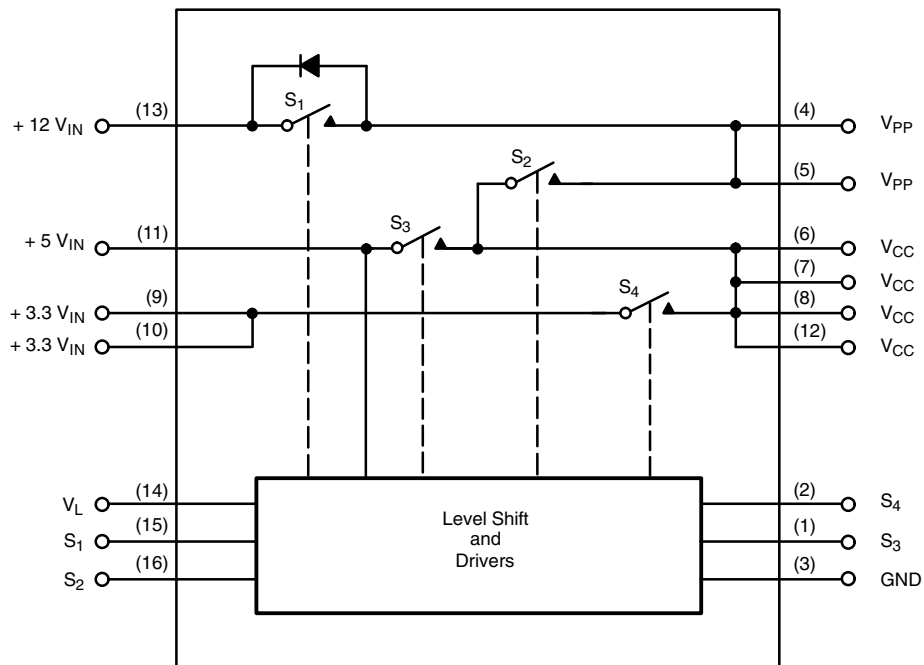

TRUTH TABLE - S_1 THROUGH S_4

Logic	Switch
0	OFF
1	ON

ABSOLUTE MAXIMUM RATINGS			
Parameter		Limit	Unit
Voltages Referenced to Ground			
V_L		7	V
+ 12 V_{IN}		15	
+ 5 V_{IN}		7	
+ 3.3 V_{IN}		7	
S_1 through S_4 (CMOS Inputs)		$V_L + 0.5$	
$I_{OUT} V_{PP}$		300	mA
V_{CC}		7	V
V_{PP}		15	
All Pins		- 0.5	
$I_{OUT} V_{CC}$		1.5	A
PD Max:	$(T_A = 25\text{ }^\circ\text{C})$	710	mW
	$(T_A = 70\text{ }^\circ\text{C})$	390	
Junction Temperature		125	$^\circ\text{C}$
Thermal Ratings $R_{\theta JA}$		140	$^\circ\text{C/W}$

Stresses beyond those listed under "Absolute Maximum Ratings" may cause permanent damage to the device. These are stress ratings only, and functional operation of the device at these or any other conditions beyond those indicated in the operational sections of the specifications is not implied. Exposure to absolute maximum rating conditions for extended periods may affect device reliability.

RECOMMENDED OPERATING CONDITIONS			
Parameter		Limit	Unit
+ 12 V_{IN}		12 V \pm 10 %	V
+ 5 V_{IN} (must be present)		5 V \pm 10 %	
+ 3.3 V_{IN}		3.3 V \pm 10 %	
$I_{OUT} V_{CC}$		1	A
$I_{OUT} V_{PP}$		150	mA
V_L		5.0 V \pm 10 %	V

SPECIFICATIONS						
Parameter	Symbol	Test Conditions Unless Otherwise Specified + 5 $V_{IN} = 5\text{ V}$, + 3.3 $V_{IN} = 3.3\text{ V}$ + 12 $V_{IN} = 12\text{ V}$, $V_L = 5.0\text{ V}$, GND = 0 V	Limits C Suffix, 0 to 70 $^\circ\text{C}$			Unit
			Min ^a	Typ	Max ^a	
Switch 1						
On Resistance	R_{ON}	$I = 120\text{ mA}$, + 12 $V_{IN} = 10.8\text{ V}$ $S_1 = V_L$, $S_2 = \text{GND}$	$T_A = 25\text{ }^\circ\text{C}$		200	m Ω
			$T_A = 70\text{ }^\circ\text{C}$		250	
Off Current (+ 12 V_{IN} to V_{PP})	I_{OFF}	+ 12 $V_{IN} = 13.2\text{ V}$, $V_{PP} = 0\text{ V}$ $S_1 = \text{GND}$	$T_A = 25\text{ }^\circ\text{C}$		1	μA
			$T_A = 70\text{ }^\circ\text{C}$		10	
Switching Time	$t_{S1(on)}$	$C_L = 0.1\text{ }\mu\text{F}$, $S_2 = \text{Low}$, $R_L = 100\text{ }\Omega$, See Figure 1		0.1	1	μs
	$t_{S1(off)}$			0.5	4	
Switch 2						
On Resistance	R_{ON}	$I = 120\text{ mA}$, + 12 $V_{IN} = 10.8\text{ V}$ $S_2 = S_3 = V_L$	$T_A = 25\text{ }^\circ\text{C}$		300	m Ω
			$T_A = 70\text{ }^\circ\text{C}$		350	
Off Current	I_{OFF}	$V_{PP} = 13.2\text{ V}$, $V_{CC} = 0\text{ V}$ + 12 $V_{IN} = 13.2\text{ V}$	$T_A = 25\text{ }^\circ\text{C}$		1	μA
			$T_A = 70\text{ }^\circ\text{C}$		10	
Switching Time	$t_{S2(on)}$	$C_L = 0.1\text{ }\mu\text{F}$, $R_L = 100\text{ }\Omega$, $S_1 = S_4 = \text{GND}$, $S_3 = V_L$, See Figure 1		0.1	1	μs
	$t_{S2(off)}$			0.5	4	



SPECIFICATIONS							
Parameter	Symbol	Test Conditions Unless Otherwise Specified + 5 V _{IN} = 5 V, + 3.3 V _{IN} = 3.3 V + 12 V _{IN} = 12 V, V _L = 5.0 V, GND = 0 V		Limits C Suffix, 0 to 70 °C			Unit
				Min ^a	Typ	Max ^a	
Switch 3							
On Resistance	R _{ON}	I = 500 mA, + 12 V _{IN} = 10.8 V S ₃ = V _L	T _A = 25 °C			200	mΩ
			T _A = 70 °C			250	
Off Current	I _{OFF}	+ 5 V _{IN} = 5 V, V _{CC} = 0 V	T _A = 25 °C			1	μA
			T _A = 70 °C			10	
Switching Time	t _{d(on)}	+ 5 V _{IN} = 5 V, C _L = 0.1 μF, V _{CC} to GND R _L = 100 Ω, V _{CC} to GND, See Figure 2		1			μs
	t _{ramp(on)}			200			
	t _{S3(off)}			0.5		4	
Switch 4							
On Resistance	R _{ON}	I = 500 mA, + 12 V _{IN} = 10.8 V S ₄ = V _L	T _A = 25 °C			150	mΩ
			T _A = 70 °C			185	
Off Current	I _{OFF}	+ 3.3 V _{IN} = 3.6 V, V _{CC} = 0 V S ₂ = S ₃ = S ₄ = GND	T _A = 25 °C			1	μA
			T _A = 70 °C			10	
Switching Time	t _{d(on)}	+ 3.3 V _{IN} = 3.3 V, C _L = 0.1 μF, S ₃ = GND R _L = 100 Ω, See Figure 2		1			μs
	t _{ramp(on)}			200			
	t _{S4(off)}			0.5		4	
Power Supply							
+ 12 V _{IN} Current	I _{+12VIN(1)}	S ₁ = S ₄ = GND, S ₂ = S ₃ = V _L				10	μA
	I _{+12VIN(2)}	S ₁ = S ₄ = V _L , S ₂ = S ₃ = GND				10	
V _L Current	I _{VL(1)}	S ₁ = S ₄ = GND, S ₂ = S ₃ = V _L				10	
	I _{VL(2)}	S ₁ = S ₄ = V _L , S ₂ = S ₃ = GND				10	
Switch Control Inputs							
Input Voltage High	V _{I(H)}		V _L = 3.3 V	2.8	2.4		V
			V _L = 5 V	4.0	3.3		
Input Voltage Low	V _{I(L)}		V _L = 3.3 V		1.1	0.4	
			V _L = 5 V		1.5	0.8	
Input Hysteresis ^b	V _{I(H)} - V _{I(L)}		V _L = 3.3 V	0.5	1.3		
			V _L = 5 V	0.8	1.8		
Input Current High	I _{I(H)}	S ₁ through S ₄ = V _L , V _L = 5 V				1.0	μA
Input Current Low	I _{I(L)}	S ₁ through S ₄ = GND, V _L = 5 V	- 1.0				

Notes:

- a. The algebraic convention whereby the most negative value is a minimum and the most positive a maximum, is used in this data sheet.
- b. Guaranteed by design, not subject to production testing.

TIMING WAVEFORMS

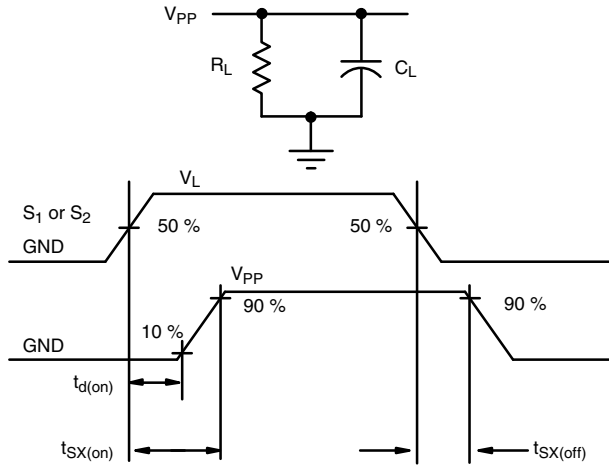

Figure 1. $t_{d(on)}$ and $t_{sx(on)}$

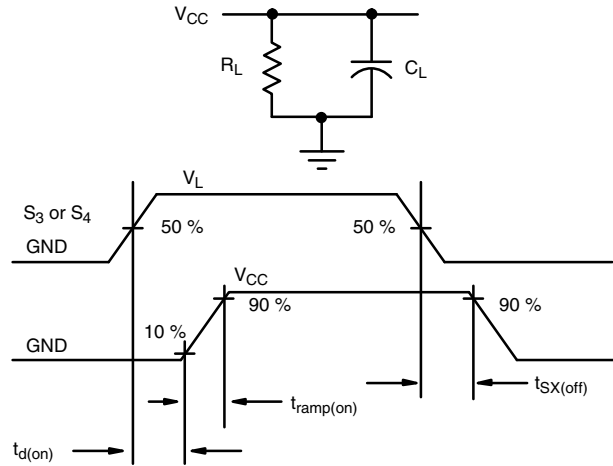
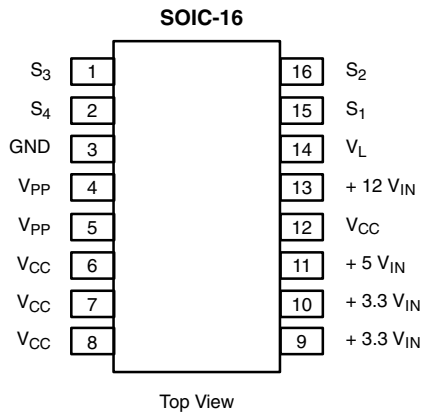

Figure 2. $t_{ramp(on)}$

PIN CONFIGURATION AND ORDERING INFORMATION



ORDERING INFORMATION		
Part Number	Temperature Range	Package
Si9711CY	0 to 70 °C	SOIC-16
Si9711CY-T1		
Si9711CY-T1-E3		

Pin Number	Symbol	Description
1	S ₃	Control input for selecting + 5 V _{IN} to V _{CC} . The PC Card terminology for this pin is V _{CC} _EN ₁ .
2	S ₄	Control input for selecting + 3.3 V _{IN} to V _{CC} . The PC Card terminology for this pin is V _{CC} _EN ₀ .
3	GND	Ground connection.
4, 5	V _{PP}	Program and peripheral voltage to PC Card slot.
6, 7, 8, 12	V _{CC}	Supply voltage to slot.
9, 10	+ 3.3 V _{IN}	+ 3.3 V supply.
11	+ 5 V _{IN}	+5 V supply.
13	+ 12 V _{IN}	+ 12 V supply.
14	V _L	Rail voltage for switch control inputs, selectable to 5 V or 3.3 V.
15	S ₁	Control input for selecting + 12 V _{IN} to V _{PP} . The PC Card terminology for this pin is V _{PP} _EN ₁ .
16	S ₂	Control input for selecting V _{CC} to V _{PP} . The PC Card terminology for this pin is V _{PP} _EN ₀ .



TYPICAL CHARACTERISTICS 25 °C unless otherwise noted

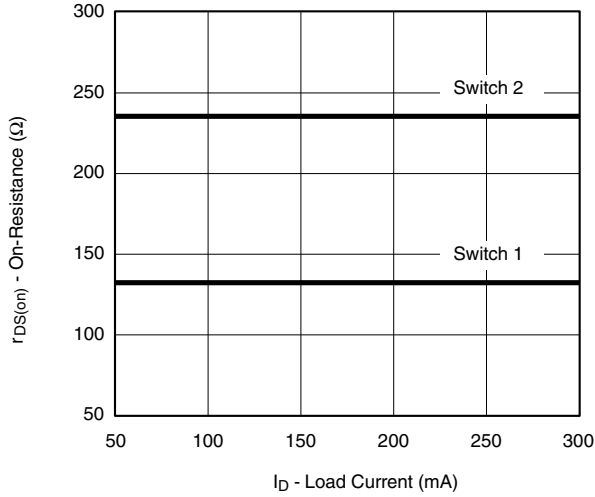

On-Resistance vs. Load Current

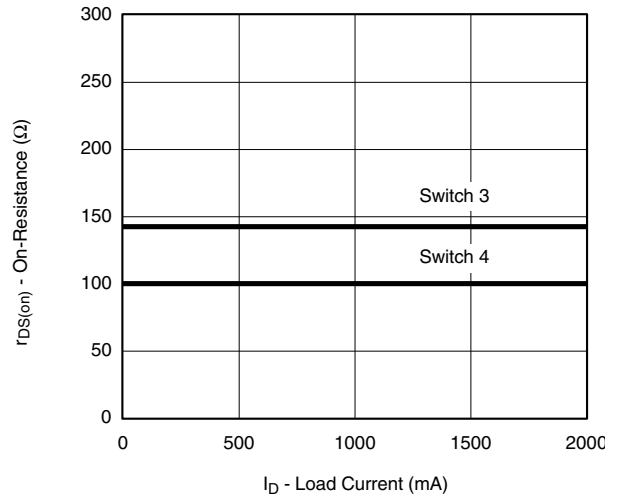

On-Resistance vs. Load Current

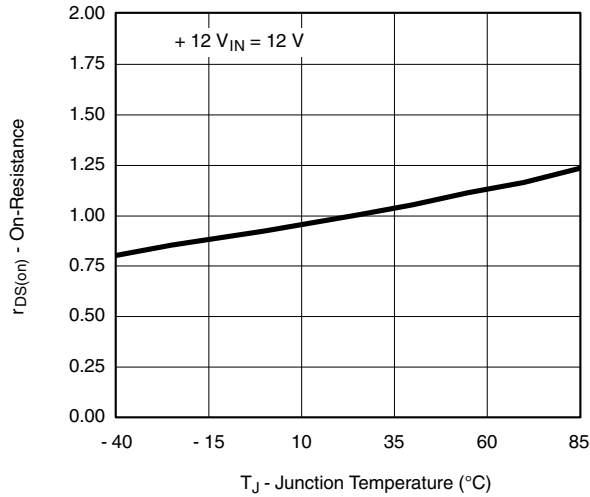

**Switch 1-4
On-Resistance vs. Junction Temperature**

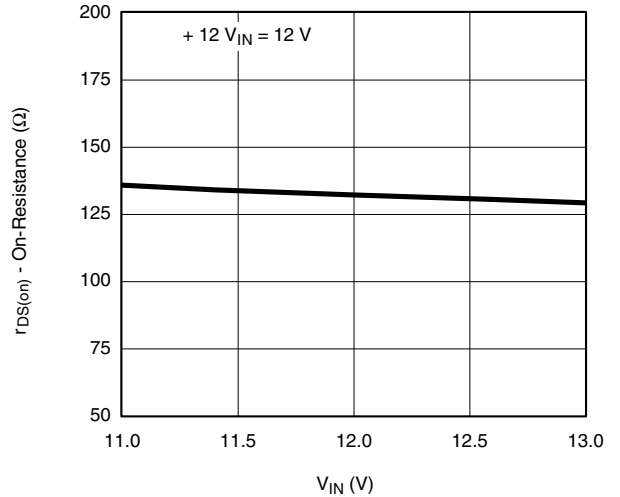

Switch 1, On-Resistance vs. V_{IN}

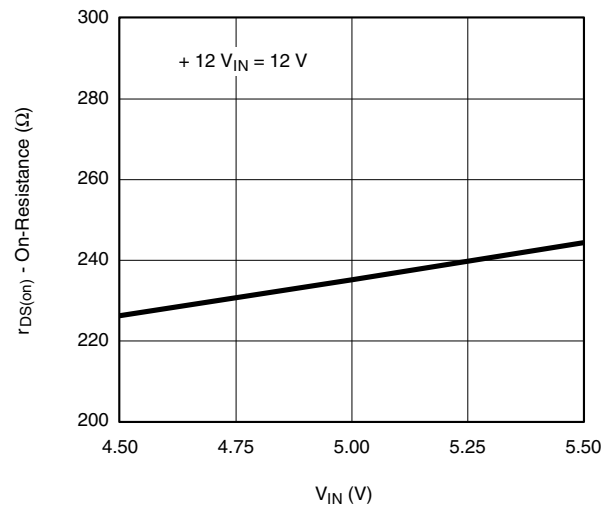

Switch 2, On-Resistance vs. V_{IN}

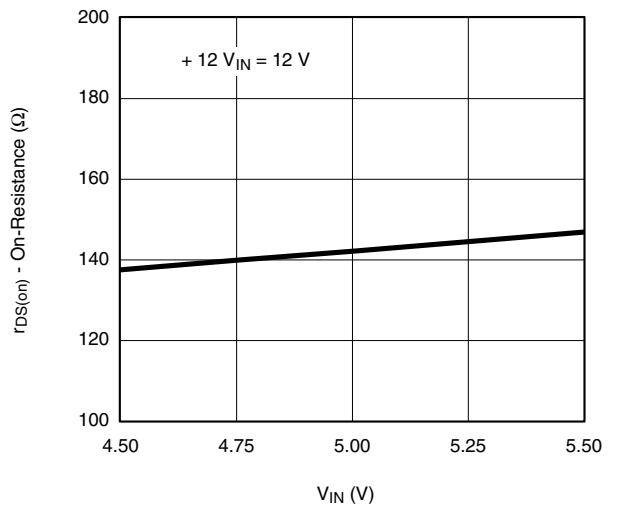

Switch 3, On-Resistance vs. V_{IN}



TYPICAL CHARACTERISTICS 25 °C unless otherwise noted

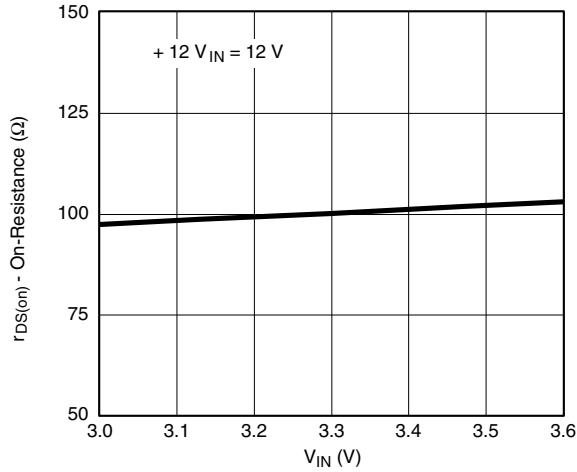

Switch 4, On-Resistance vs. V_{IN}

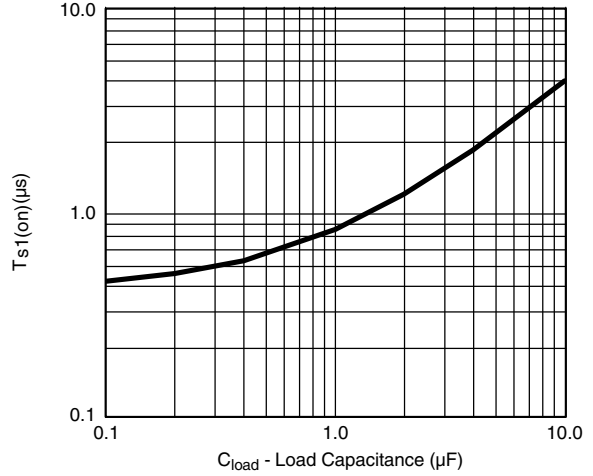

Switch 1, Switching Time vs. Load Capacitance

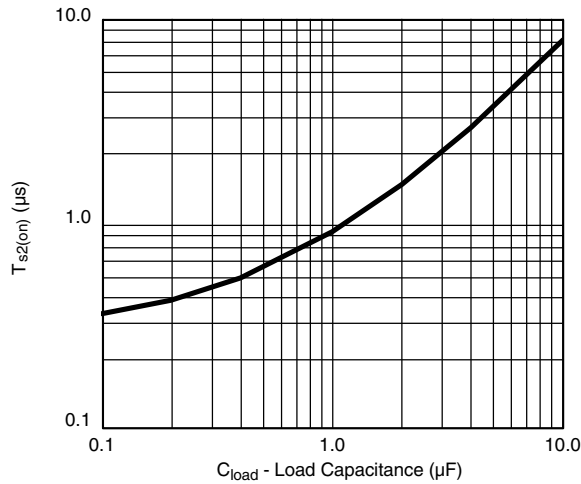

Switch 2, Switching Time vs. Load Capacitance

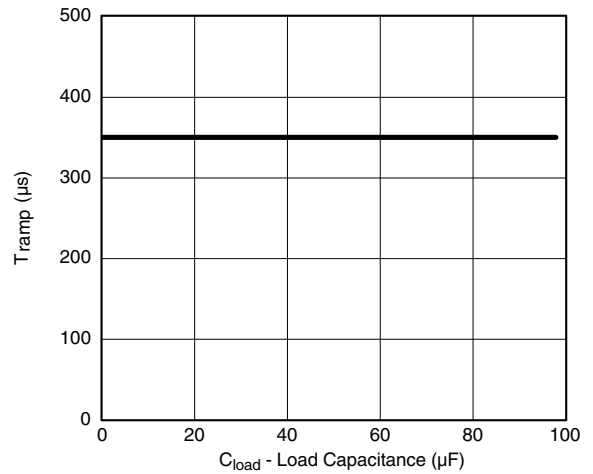

Switch 3, Ramp Time vs. Load Capacitance

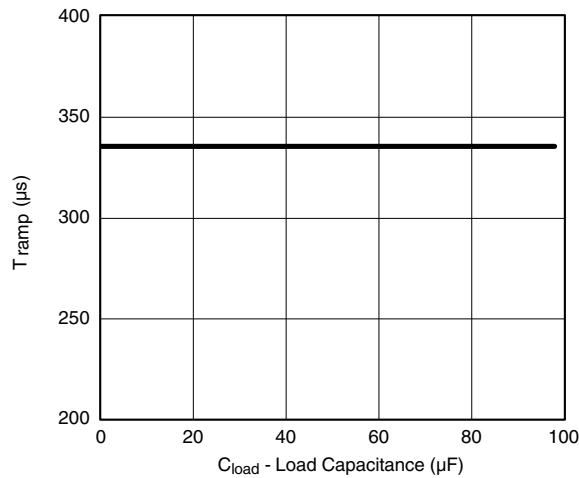

Switch 4, Ramp Time vs. Load Capacitance

Vishay Siliconix maintains worldwide manufacturing capability. Products may be manufactured at one of several qualified locations. Reliability data for Silicon Technology and Package Reliability represent a composite of all qualified locations. For related documents such as package/tape drawings, part marking, and reliability data, see <http://www.vishay.com/ppg?70022>.



SOIC (NARROW): 16-LEAD (POWER IC ONLY)
JEDEC Part Number: MS-012

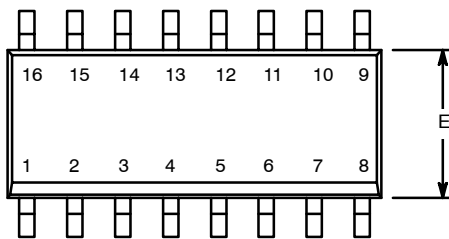

Dim	MILLIMETERS		INCHES	
	Min	Max	Min	Max
A	1.35	1.75	0.053	0.069
A ₁	0.10	0.20	0.004	0.008
B	0.38	0.51	0.015	0.020
C	0.18	0.23	0.007	0.009
D	9.80	10.00	0.385	0.393
E	3.80	4.00	0.149	0.157
e	1.27 BSC		0.050 BSC	
H	5.80	6.20	0.228	0.244
L	0.50	0.93	0.020	0.037
∅	0°	8°	0°	8°

ECN: S-40080—Rev. A, 02-Feb-04
DWG: 5912

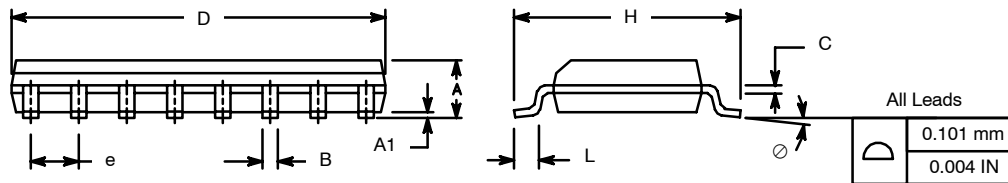



Disclaimer

ALL PRODUCT, PRODUCT SPECIFICATIONS AND DATA ARE SUBJECT TO CHANGE WITHOUT NOTICE TO IMPROVE RELIABILITY, FUNCTION OR DESIGN OR OTHERWISE.

Vishay Intertechnology, Inc., its affiliates, agents, and employees, and all persons acting on its or their behalf (collectively, "Vishay"), disclaim any and all liability for any errors, inaccuracies or incompleteness contained in any datasheet or in any other disclosure relating to any product.

Vishay makes no warranty, representation or guarantee regarding the suitability of the products for any particular purpose or the continuing production of any product. To the maximum extent permitted by applicable law, Vishay disclaims (i) any and all liability arising out of the application or use of any product, (ii) any and all liability, including without limitation special, consequential or incidental damages, and (iii) any and all implied warranties, including warranties of fitness for particular purpose, non-infringement and merchantability.

Statements regarding the suitability of products for certain types of applications are based on Vishay's knowledge of typical requirements that are often placed on Vishay products in generic applications. Such statements are not binding statements about the suitability of products for a particular application. It is the customer's responsibility to validate that a particular product with the properties described in the product specification is suitable for use in a particular application. Parameters provided in datasheets and/or specifications may vary in different applications and performance may vary over time. All operating parameters, including typical parameters, must be validated for each customer application by the customer's technical experts. Product specifications do not expand or otherwise modify Vishay's terms and conditions of purchase, including but not limited to the warranty expressed therein.

Except as expressly indicated in writing, Vishay products are not designed for use in medical, life-saving, or life-sustaining applications or for any other application in which the failure of the Vishay product could result in personal injury or death. Customers using or selling Vishay products not expressly indicated for use in such applications do so at their own risk. Please contact authorized Vishay personnel to obtain written terms and conditions regarding products designed for such applications.

No license, express or implied, by estoppel or otherwise, to any intellectual property rights is granted by this document or by any conduct of Vishay. Product names and markings noted herein may be trademarks of their respective owners.

Material Category Policy

Vishay Intertechnology, Inc. hereby certifies that all its products that are identified as RoHS-Compliant fulfill the definitions and restrictions defined under Directive 2011/65/EU of The European Parliament and of the Council of June 8, 2011 on the restriction of the use of certain hazardous substances in electrical and electronic equipment (EEE) - recast, unless otherwise specified as non-compliant.

Please note that some Vishay documentation may still make reference to RoHS Directive 2002/95/EC. We confirm that all the products identified as being compliant to Directive 2002/95/EC conform to Directive 2011/65/EU.

Vishay Intertechnology, Inc. hereby certifies that all its products that are identified as Halogen-Free follow Halogen-Free requirements as per JEDEC JS709A standards. Please note that some Vishay documentation may still make reference to the IEC 61249-2-21 definition. We confirm that all the products identified as being compliant to IEC 61249-2-21 conform to JEDEC JS709A standards.