

TOSHIBA Photo-interrupter Infrared LED+Phototransistor

TLP842

- Still Camera and Digital Still Camera
- Video Camera
- Floppy Disk Drive
- Personal Equipment and Small-sized OA Equipment

The TLP842 is photointerrupter which consists of a GaAs infrared LED and an Si phototransistor.

It is an ultra compact package and has a wide gap width. More it has a narrow slit and a high resolution.

- Ultra compact package: 3.5×2.6×2.9mm
- Gap width: 1.2 mm
- High resolution: Slit width = 0.15 mm
- High current transfer ratio: $I_C/I_F = 3\%$ (min)
- Material of the package: Polybutylene terephthalate (UL94V-0)
- Lead-free product

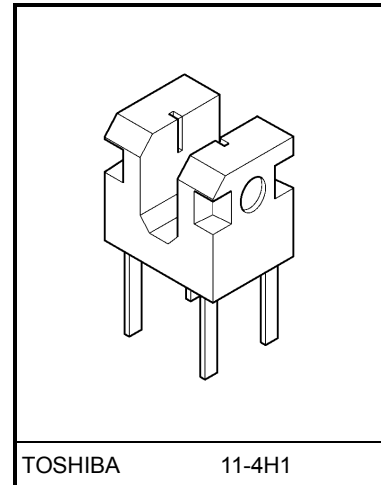

Weight: 0.035 g (typ.)

Maximum Ratings (Ta = 25°C)

Characteristics		Symbol	Rating	Unit
LED	Forward current	I_F	30	mA
	Forward current derating (Ta>25°C)	$\Delta I_F/^\circ\text{C}$	-0.33	mA/°C
	Reverse voltage	V_R	5	V
Detector	Collector-emitter voltage	V_{CEO}	35	V
	Emitter-collector voltage	V_{ECO}	5	V
	Collector power dissipation	P_C	75	mW
	Collector power dissipation derating (Ta>25°C)	$\Delta P_C/^\circ\text{C}$	-1	mW/°C
	Collector current	I_C	50	mA
Operating temperature range		T_{opr}	-30 to 85	°C
Storage temperature range		T_{stg}	-40 to 100	°C
Soldering temperature (5s) (Note 1)		T_{sol}	260	°C

Note 1 : At least 1mm from body

Note 2 : It is composed of the Arabic numerals four digits, one digit from the left shows Rank indication and the rest three digits show Weekly code.

※Rank indication Without a mark : None R : R rank device

※Weekly code: (Three digits)

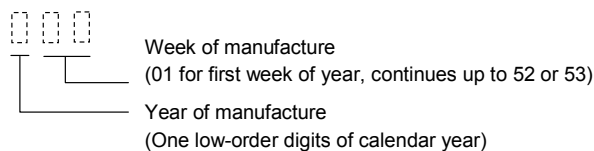

Marking (Note 2)

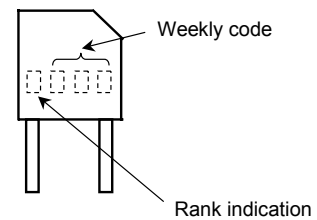

Optical and Electrical Characteristics (Ta = 25°C)

Characteristics		Symbol	Test conditions	Min	Typ.	Max	Unit	
LED	Forward voltage	V_F	$I_F = 10 \text{ mA}$	1.00	1.23	1.40	V	
	Reverse current	I_R	$V_R = 5 \text{ V}$	—	—	10	μA	
	Peak emission wavelength	λ_P	$I_F = 10 \text{ mA}$	—	940	—	nm	
Detector	Dark current	$I_D (I_{CEO})$	$V_{CE} = 24 \text{ V}, I_F = 0$	—	—	0.1	μA	
	Peak sensitivity wavelength	λ_P	—	—	820	—	nm	
Coupled	Current transfer ratio	I_C/I_F	$V_{CE} = 2 \text{ V}$ $I_F = 5 \text{ mA}$	TLP842	3	—	24	%
				TLP842 (R)	4	—	20	
	Collector-emitter saturation voltage	$V_{CE} (\text{sat})$	$I_F = 10 \text{ mA}, I_C = 0.25 \text{ mA}$	—	0.1	0.4	V	
	Rise time	t_r	$V_{CE} = 5 \text{ V}, I_C = 1 \text{ mA}, R_L = 1 \text{ k}\Omega$ (Note 3)	—	15	50	μs	
Fall time	t_f	—		15	50			

Note 3 : Switching time measurement circuit and waveform

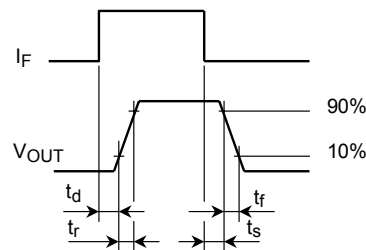
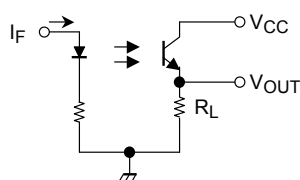

Precautions

- When removing flux with chemicals after soldering, clean only the leads on the soldering side; do not dip the whole package for cleaning.
Chemicals remaining on an LED or photo transistor light emitter or receiver, if any, would have a bad influence to the optical characteristics and it may severely lower the conversion efficiency.
- Care must be taken in relation to the environment in which the device is to be installed. Oil or chemicals may cause the package to melt or crack.
- The device should be mounted on an unwarped surface.
- Conversion efficiency falls over time due to the current which flows in the infrared LED. When designing a circuit, take into account this change in conversion efficiency over time. The ratio of fluctuation in conversion efficiency to fluctuation in infrared LED optical output is 1:1.

$$\frac{I_C/I_F(t)}{I_C/I_F(0)} = \frac{P_o(t)}{P_o(0)}$$

Package Dimensions: TOSHIBA 11-4H1

Unit: mm
 Tolerance : $\pm 0.2\text{mm}$ unless otherwise specified
 () : Reference value

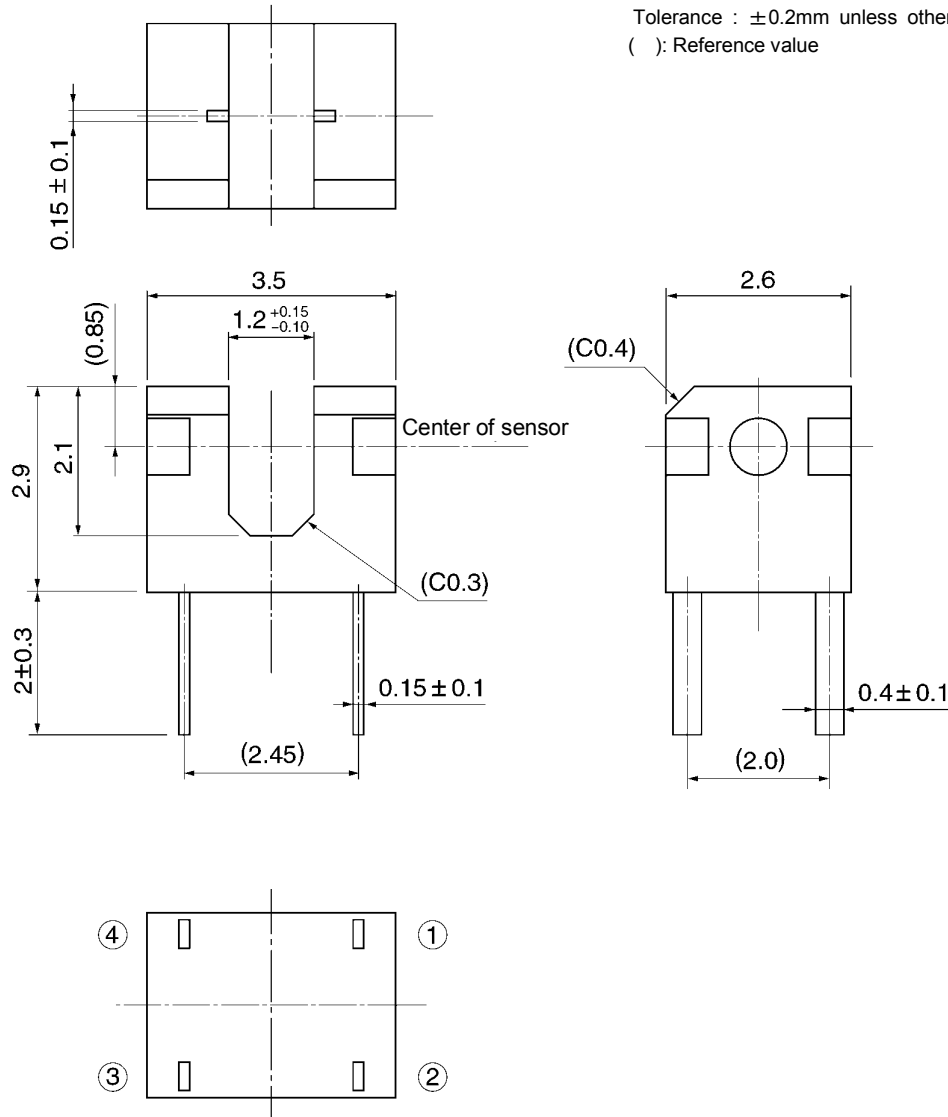

Weight : 0.035g (typ.)

Pin Connection

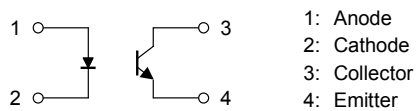

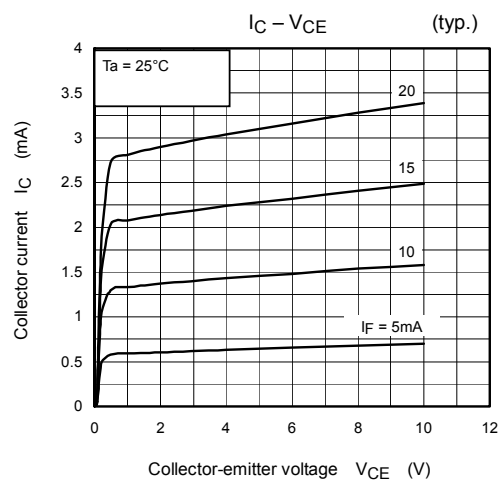
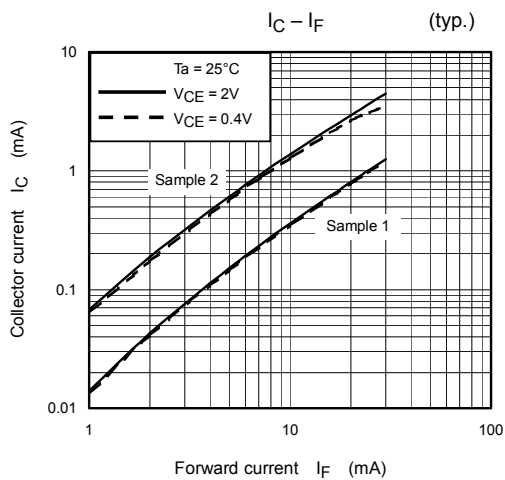
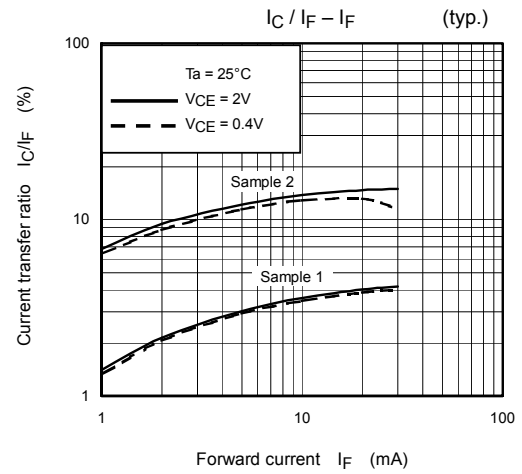
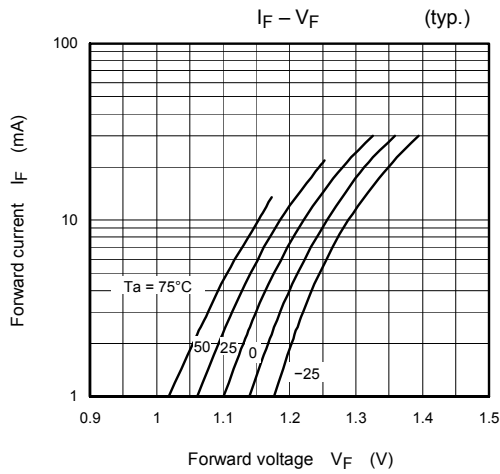
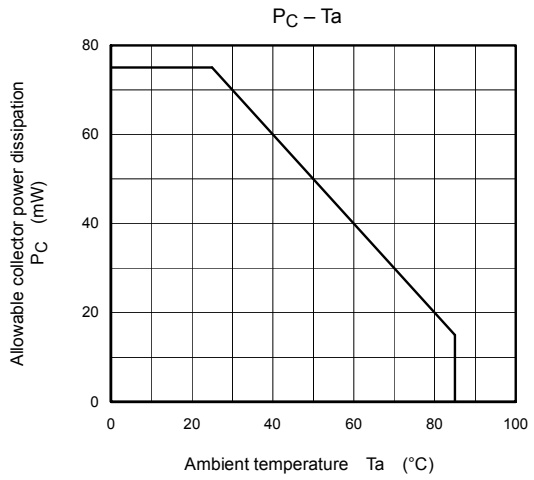
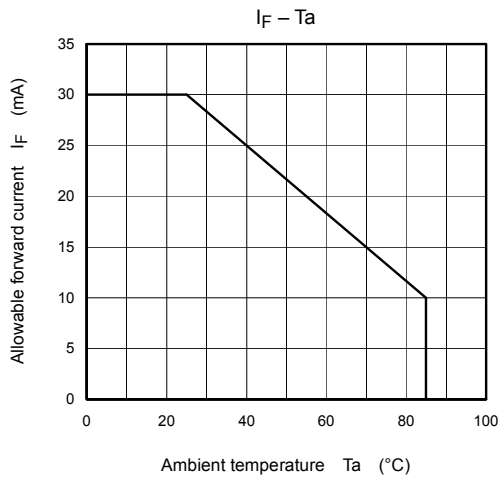

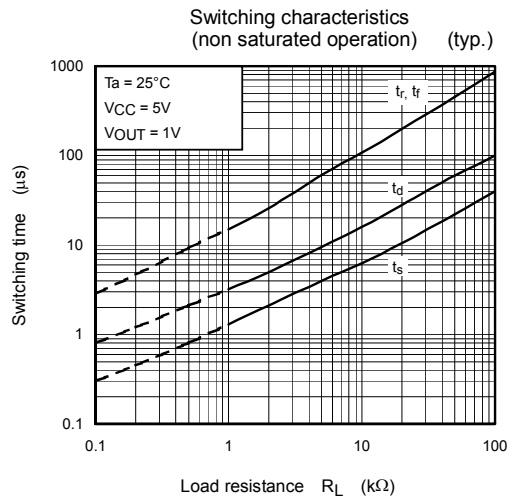
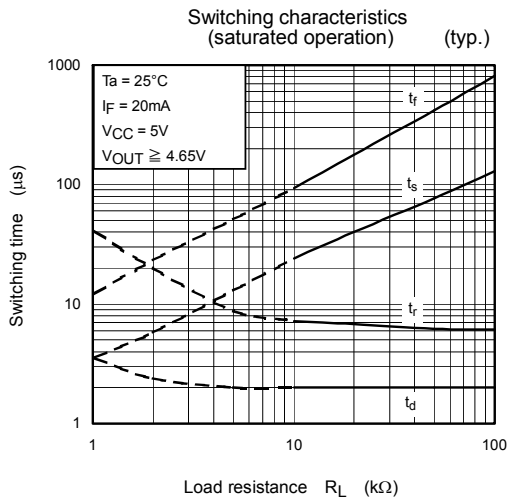
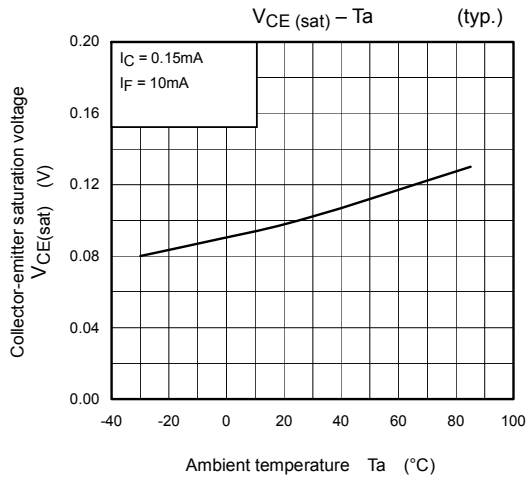
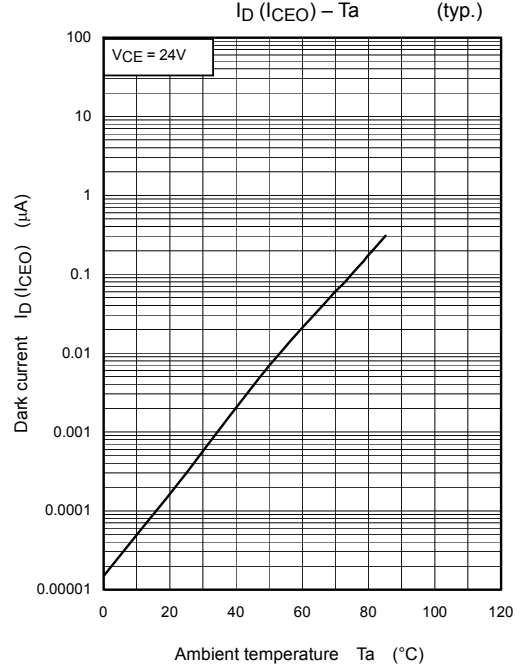
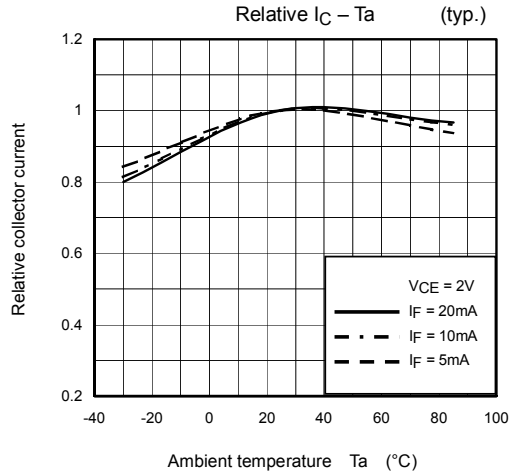

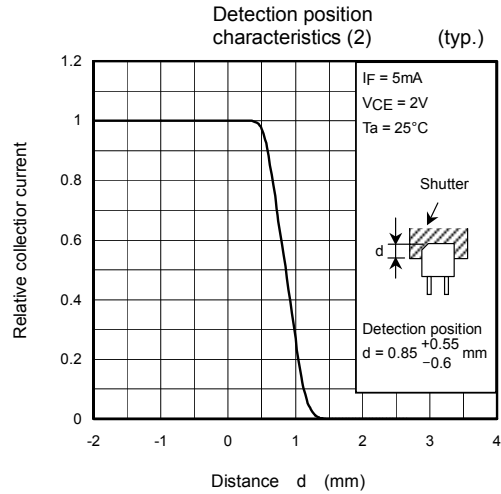
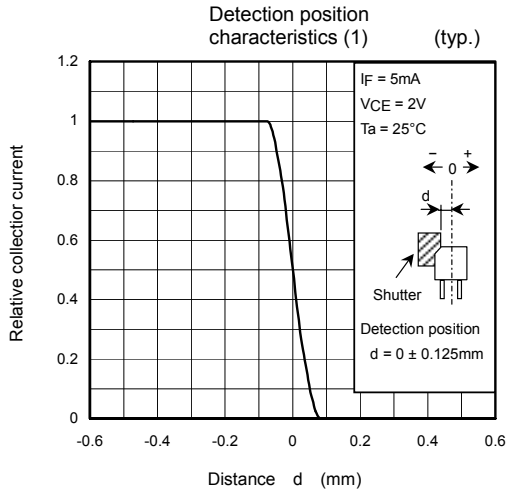

Relative Positioning of Shutter and Device

For normal operation, position the shutter and the device as shown in the figure below. By considering the device's detection direction characteristic and switching time, determine the shutter slit width and pitch.

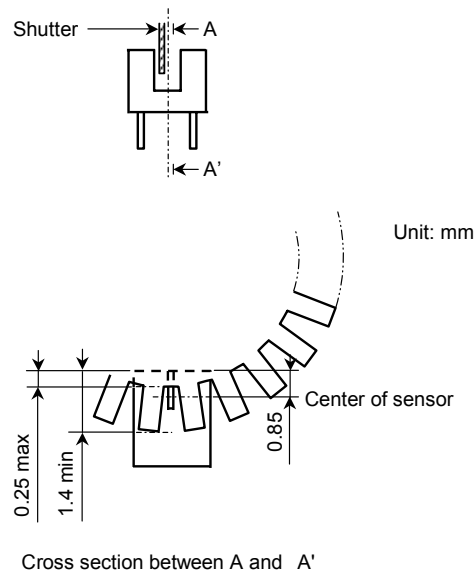

RESTRICTIONS ON PRODUCT USE

030619EAC

- The information contained herein is subject to change without notice.
- The information contained herein is presented only as a guide for the applications of our products. No responsibility is assumed by TOSHIBA for any infringements of patents or other rights of the third parties which may result from its use. No license is granted by implication or otherwise under any patent or patent rights of TOSHIBA or others.
- TOSHIBA is continually working to improve the quality and reliability of its products. Nevertheless, semiconductor devices in general can malfunction or fail due to their inherent electrical sensitivity and vulnerability to physical stress. It is the responsibility of the buyer, when utilizing TOSHIBA products, to comply with the standards of safety in making a safe design for the entire system, and to avoid situations in which a malfunction or failure of such TOSHIBA products could cause loss of human life, bodily injury or damage to property.
In developing your designs, please ensure that TOSHIBA products are used within specified operating ranges as set forth in the most recent TOSHIBA products specifications. Also, please keep in mind the precautions and conditions set forth in the "Handling Guide for Semiconductor Devices," or "TOSHIBA Semiconductor Reliability Handbook" etc..
- The TOSHIBA products listed in this document are intended for usage in general electronics applications (computer, personal equipment, office equipment, measuring equipment, industrial robotics, domestic appliances, etc.). These TOSHIBA products are neither intended nor warranted for usage in equipment that requires extraordinarily high quality and/or reliability or a malfunction or failure of which may cause loss of human life or bodily injury ("Unintended Usage"). Unintended Usage include atomic energy control instruments, airplane or spaceship instruments, transportation instruments, traffic signal instruments, combustion control instruments, medical instruments, all types of safety devices, etc.. Unintended Usage of TOSHIBA products listed in this document shall be made at the customer's own risk.
- TOSHIBA products should not be embedded to the downstream products which are prohibited to be produced and sold, under any law and regulations.
- GaAs(Gallium Arsenide) is used in this product. The dust or vapor is harmful to the human body. Do not break, cut, crush or dissolve chemically.